

CA Workload Automation iXp

User Guide

Release 7.1 SP1



This Documentation, which includes embedded help systems and electronically distributed materials, (hereinafter referred to as the "Documentation") is for your informational purposes only and is subject to change or withdrawal by CA at any time.

This Documentation may not be copied, transferred, reproduced, disclosed, modified or duplicated, in whole or in part, without the prior written consent of CA. This Documentation is confidential and proprietary information of CA and may not be disclosed by you or used for any purpose other than as may be permitted in (i) a separate agreement between you and CA governing your use of the CA software to which the Documentation relates; or (ii) a separate confidentiality agreement between you and CA.

Notwithstanding the foregoing, if you are a licensed user of the software product(s) addressed in the Documentation, you may print or otherwise make available a reasonable number of copies of the Documentation for internal use by you and your employees in connection with that software, provided that all CA copyright notices and legends are affixed to each reproduced copy.

The right to print or otherwise make available copies of the Documentation is limited to the period during which the applicable license for such software remains in full force and effect. Should the license terminate for any reason, it is your responsibility to certify in writing to CA that all copies and partial copies of the Documentation have been returned to CA or destroyed.

TO THE EXTENT PERMITTED BY APPLICABLE LAW, CA PROVIDES THIS DOCUMENTATION "AS IS" WITHOUT WARRANTY OF ANY KIND, INCLUDING WITHOUT LIMITATION, ANY IMPLIED WARRANTIES OF MERCHANTABILITY, FITNESS FOR A PARTICULAR PURPOSE, OR NONINFRINGEMENT. IN NO EVENT WILL CA BE LIABLE TO YOU OR ANY THIRD PARTY FOR ANY LOSS OR DAMAGE, DIRECT OR INDIRECT, FROM THE USE OF THIS DOCUMENTATION, INCLUDING WITHOUT LIMITATION, LOST PROFITS, LOST INVESTMENT, BUSINESS INTERRUPTION, GOODWILL, OR LOST DATA, EVEN IF CA IS EXPRESSLY ADVISED IN ADVANCE OF THE POSSIBILITY OF SUCH LOSS OR DAMAGE.

The use of any software product referenced in the Documentation is governed by the applicable license agreement and such license agreement is not modified in any way by the terms of this notice.

The manufacturer of this Documentation is CA.

Provided with "Restricted Rights." Use, duplication or disclosure by the United States Government is subject to the restrictions set forth in FAR Sections 12.212, 52.227-14, and 52.227-19(c)(1) - (2) and DFARS Section 252.227-7014(b)(3), as applicable, or their successors.

Copyright © 2012 CA. All rights reserved. All trademarks, trade names, service marks, and logos referenced herein belong to their respective companies.

TABLE OF CONTENTS

1	INTRODUCTION	7
2	ARCHITECTURE	8
2.1	Processing Example.....	10
2.1.1	Data Refresh Cycle	10
2.1.2	On-Demand Activity Example.....	10
2.1.3	Log File Retrieval	10
2.2	Security	11
3	VIEWING JOBS.....	12
3.1.1	Customizing the GUI	12
3.1.2	Graphical Views.....	13
3.2	The Console View	13
3.2.1	Time View	16
3.2.1.1	Setting Chart Duration	17
3.2.1.2	Retrieve Run Data.....	18
3.2.2	Sort Order in Console View	18
3.3	Job Flow View	20
3.3.1	Zoom.....	21
3.3.2	Job Flow View Order	22
3.3.3	Names in Job Flow View	23
3.3.4	Global Variable Symbol	24
3.4	The Job Detail View	26
3.5	The Tree View	30
3.6	Selecting Multiple Jobs	32
4	iXp MENU BAR.....	33
4.1	File Menu:.....	33
4.1.1	File►User Command	33
4.1.1.1	File►User Command►Job.....	35
4.1.1.2	File►User Command►Alarm.....	36
4.1.1.3	File►User Command►Context Free	36
4.1.2	File►CLI.....	37
4.1.3	File►Print.....	39
4.1.3.1	Print Tiling	40
4.1.4	File►Save Session Settings	40
4.1.5	File►Save View as JIL.....	40
4.1.6	File►Set Time Zone.....	40
4.1.7	File►Go Offline.....	41
4.1.8	File►Change Password.....	41
4.1.9	File►Sendevent.....	42
4.1.9.1	Sendevent►Standard.....	43
4.1.9.2	Sendevent►Multi-Select.....	43
4.1.9.3	Sendevent►CHANGE_STATUS.....	44
4.1.9.4	Sendevent►ALARM	45
4.1.9.5	Sendevent►COMMENT	46

4.1.9.6	Sendevent►SET_GLOBAL.....	47
4.1.9.7	Sendevent►CHANGE_PRIORITY.....	48
4.1.9.8	Sendevent►SEND_SIGNAL.....	49
4.1.10	File►Retrieve Run Data.....	49
4.1.11	File►Retrieve Alarm Data.....	50
4.2	Edit Menu.....	50
4.2.1	Edit►Undo:.....	50
4.2.2	Edit►Edit Filters.....	50
4.2.3	Edit►Edit Preferences.....	50
4.2.3.1	Color Editor.....	54
4.2.3.2	Filter Editor.....	55
4.3	View Menu.....	56
4.3.1	View►Find Job By Name.....	56
4.3.2	View►Find Job By.....	57
4.3.3	View►Find Admin Filter.....	59
4.3.4	View►Find Personal Filter.....	59
4.3.5	View►Find Group Filter.....	60
4.3.6	View►Global Variables.....	60
4.3.7	View►Job Overrides.....	61
4.3.8	View►Expand.....	62
4.3.9	View►Expand All.....	62
4.3.10	View►Transitive Closure.....	63
4.3.11	View►Display Alarm Button.....	63
4.3.12	View►Alarm Manager on Top.....	63
4.3.13	View►Lock Job Name Column.....	63
4.4	View►Flow View.....	64
4.4.1	View►Flow View►Display Flow View.....	64
4.4.2	View►Flow View►Show Print Grid.....	64
4.4.3	View►Flow View►Stream Jobs.....	64
4.4.4	View►Flow View►Show Job Names.....	64
4.4.5	View►Flow View►Truncate Job Names.....	65
4.4.6	View►Flow View►Keep First 8 Letters.....	65
4.4.7	View►Flow View►Hide Job Names.....	65
4.4.8	View►Flow View►Show Arrows.....	66
4.4.9	View►Flow View►Hide Out of Box Arrows.....	66
4.4.10	View►Flow View►Hide All Arrows.....	66
4.4.11	View►Flow View►Hide Icons.....	66
4.4.12	View►Flow View►Enable Arrow Routing.....	66
4.5	Report Menu.....	68
4.5.1	Report Editor.....	68
4.5.1.1	Report Management.....	68
4.6	Definition Menu.....	72
4.6.1	Edit Calendars.....	72
4.6.1.1	Menu options.....	73
4.6.1.2	Calendar Generator Dialog.....	74
4.6.2	Edit Jobs.....	74
4.6.2.1	Menu icons.....	75

4.6.2.2	Basic page	75
4.6.2.3	Date/Time page	75
4.6.2.4	Alarm page	76
4.6.2.5	Execution page	76
4.6.2.6	Runtime page	76
4.6.2.7	Resource page	76
4.6.2.8	Permission page	76
4.6.2.9	Box page	76
4.6.2.10	File Watcher page	77
4.7	Help Menu	77
4.7.1	Graphics Help	77
4.8	Quick Find	77
5	iXp TOOL BAR	78
5.1	Instance Monitor	78
5.2	Alarm Manager	79
5.2.1	Job Control Pop-up menu in Alarm Manager	81
5.2.2	Sort Order in Alarm Manager	82
5.3	Current Filter	83
5.4	Flow View Buttons	84
6	JOB FILTERS	85
6.1	Filters Defined	85
6.1.1	Attribute Filters	85
6.1.2	Job Dependency Filters	86
6.2	How Filters Work	86
6.2.1	Filter Logic Sequence	86
6.2.2	Example Filtration Sequence	87
6.3	Filter Editor	88
6.3.1	Filter Editor File Menu	92
7	JOB TOOLS POPUP	94
7.1	Expand, Collapse, and Hide	94
7.2	Job Control	95
7.2.1	Update Job	96
7.2.2	Override Job	96
7.2.3	Change Status	96
7.3	New Filter and Update Filter	97
7.3.1	Job Dependency Filters definitions	98
7.4	User Command	100
7.5	Job Information	101
7.5.1	Job Definition	101
7.5.2	Detailed Report	101
7.5.3	Run Data	102
7.5.3.1	View Detail	103
7.5.3.2	Create Report	103
7.5.4	Log Files	103
7.5.4.1	STDOUT, STDERR, STDIN	104
7.5.4.2	Job Profile	105
7.5.4.3	Remote Agent Log	106

7.5.5	Calendars.....	107
7.6	View Statistics	109
8	iXp CLIENT CLI	111
8.1	Installation	111
8.2	Commands	113
8.2.1	ixautorep	113
8.2.2	ixsendevent	114
8.2.3	ixjil	115
8.2.1	ixautostatus	117
8.2.2	ixjob_depends	118
8.2.3	ixautocal_asc.....	119
8.2.4	ixflags.....	120
9	INTERACTIVE FORECASTING.....	121
9.1	Go Offline.....	121
9.1.1	Rewind, Play, Pause	122
9.2	Forecast Configuration	122
9.2.1	Time Settings	124
9.2.2	EP Latencies.....	124
9.2.3	Log Files	125
9.2.4	Run Times	126
9.2.5	End Statuses	128
9.2.6	Sendevents	129
9.2.1	Return iXp to Online Mode	130
9.3	View Forecast Run Data	131
9.4	Errors and Warnings	131
9.4.1	Warning for old data	131
9.4.2	No Activity Warning	132
9.4.3	iXp Client is “Out Of Memory”	132
9.4.4	iXp Client gets “EOF” Exceptions	133
10	GLOSSARY	135
10.1	iXp Related Terms	135
10.2	CA Workload Automation AE Terms	136
10.3	Symbols in this Guide.....	137
10.4	Related Documents.....	138

1 INTRODUCTION

iXp is a Java™ based graphical interface that can be launched from Java Web Start or directly from a browser. With iXp, users can monitor, control, create, update, forecast, simulate, report on and print CA Workload Automation AE job streams across multiple instances from a single window. An additional administrative tool enables administrators to manage privileges for end users by defining authorization roles.

The iXp Command Line interface enables users to view, report, control, create, update, and delete CA Workload Automation AE jobs. The command interface with the iXp Security model and do not require a local installation of the CA Workload Automation AE software.

This guide assumes familiarity with CA Workload Automation AE. Companion to this **iXp User Guide** is the **iXp Administration Guide**.

2 ARCHITECTURE

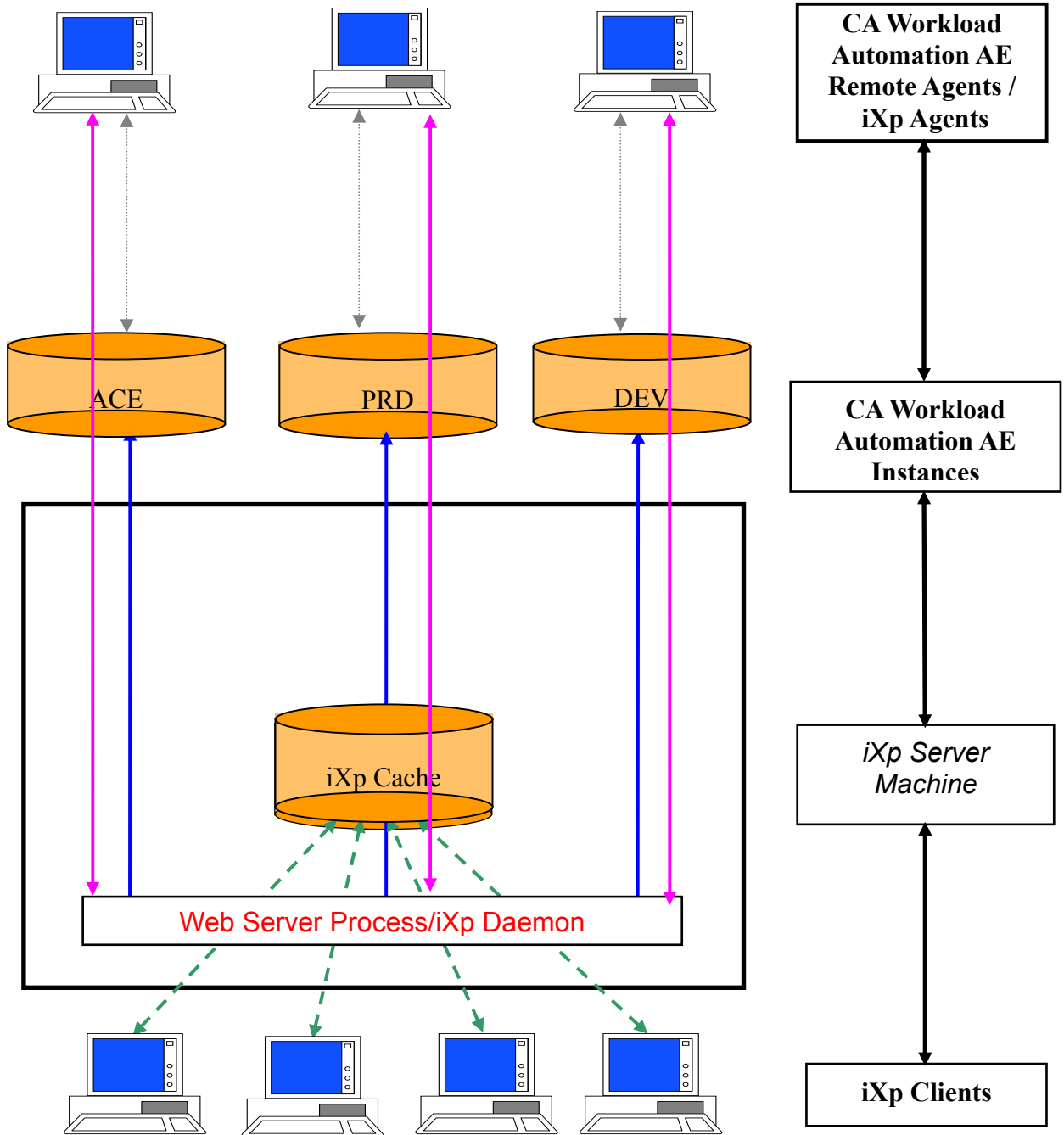

ARCHITECTURE ELEMENT	DESCRIPTION
iXp Daemon	<p>This process runs on the iXp Server machine and is the only process that runs constantly. It is a multi-threaded Java process that collects all the relevant job data from the CA Workload Automation AE instance(s), maintains the iXp Cache and supplies the data to all the iXp clients. It is started by the Web Application Server (e.g. Tomcat) as a servlet.</p>
iXp Cache	<p>These highly compressed data files in proprietary binary format include all the CA Workload Automation AE data needed by the iXp Daemon and the iXp clients.</p>
iXp Client	<p>The iXp Client is the Java™-based GUI that can be launched on any Java supported system, and the CLI that can be launched on supported systems.</p> <p>The GUI provides the capability to monitor, report, forecast, control and update job processing across the CA Workload Automation AE instances. Because the GUI is a Java applet, there is no software installation required on the machine that will launch the client.</p> <p>The CLI provides the capability to run CA Workload Automation AE commands like <i>sendevent</i>, <i>autorep</i>, <i>jil</i>, <i>job_depends</i> from any machine without installing the CA Workload Automation AE client software.</p>
iXp Agent	<p>The iXp Agent is a JAVA program that needs to run on a CA Workload Automation AE Remote Agent. The Agent enables iXp Clients to retrieve the output files created by any CA Workload Automation AE job.</p> <p>iXp also provides a PERL-based agent that has been deprecated. This program can be started automatically by the iXp Daemon when needed, or can be started as a job from CA Workload Automation AE. This program can be installed automatically by the iXp Server or manually by the iXp Administrator.</p> <p><i>The iXp Agent is not required with CA Workload Automation AE r11.3 and higher.</i></p>

2.1 Processing Example

2.1.1 Data Refresh Cycle

Following is a detailed description of the processing of each component of the architecture and the interaction between them during a normal data refresh cycle for the iXp Daemon and the Client.

- 1) The iXp Daemon reads data from the CA Workload Automation AE database(s) for each instance.
- 2) It updates the iXp Cache with the newly fetched data.
- 3) The iXp Client contacts the web application server during its refresh cycle, and reads the iXp Cache for the data refresh. Since the iXp application is a multi-threaded software, it can service multiple client requests simultaneously, if needed.

2.1.2 On-Demand Activity Example

Following is a detailed description of the processing of each component and the interaction between them when an iXp Client performs an on-demand activity such as putting a job on-hold.

- 1) The iXp Client contacts the web application server.
- 2) The web application server associates the request with a thread and asks it to perform the action to put the job on-hold.
- 3) The thread uses the JDBC connection to the database to perform the action and reports the status back to the web application server.
- 4) The web application server then reports the status back to the iXp Client and the thread exits.

2.1.3 Log File Retrieval

Following is a detailed description of the processing of each component and the interaction between them when an iXp Client requests retrieval of a log file (e.g. STDOUT) created by a job running in CA Workload Automation AE version r11 or older.

- 1) The iXp Client contacts the iXp Daemon via the web application server.
- 2) The iXp Daemon then requests the iXp Agent on the CA Workload Automation AE Agent machine (where the job ran) to read the desired log file and send the contents back to the iXp Server. If the iXp Agent is not running, then the iXp Daemon sends a message back to the Client indicating that the Agent is not running.

- 3) Once it receives the contents, the iXp Server sends the contents back to the requesting iXp Client. The iXp Client displays the contents in a browser window.

2.2 Security

There are two security methods available for controlling access to iXp.

- 1) Native iXp security
- 2) Single-Sign On (SSO)

iXp provides a native multi-layered security model that encompasses data encryption, user authorization, and optional user authentication. The same security model is applied to both the iXp GUI and the iXp CLI.

In the first model, user access to iXp requires validation of the user identity and password. All user identities and passwords are managed within iXp and have no relation to system/domain IDs and passwords.

In the second model, iXp leverages the user ID already authenticated to the Active Directory Domain or the local machine. This requires no user/password maintenance in iXp.

In either case, iXp security includes the following features.

- Data transmission between the server and client machines can be secured and encrypted through current secure HTTP technology. Also, the sensitive data stored by iXp is encrypted.
- Roles can be assigned to the iXp user identities that provide read, update and control privileges on the desired CA Workload Automation AE objects.
- The security model is very dynamic and user policies can be changed on the fly. Changes immediately take effect and a user logout is not required.
- The iXp Administrator can easily manage the security role policies through the iXp Admin Tool.

3 VIEWING JOBS

3.1 Customizing the GUI

Contact your iXp administrator for the URL of the iXp server and logon information. After logging in, you should see the iXp application as shown below.

You can verify that you are running iXp 7.1 by using the Help ► About command.

On the main GUI, shown below, drag the window size adjusters with your mouse to view all four iXp windows. A left click of the mouse on the arrow indentation on any size adjuster will move the panel all the way to the edge of the GUI window, collapsing any views in that direction. For example, a left click on the down arrow indentation on the size adjuster between the Console View and the Job Flow View will completely hide the Job Flow View and enlarge the Console View.

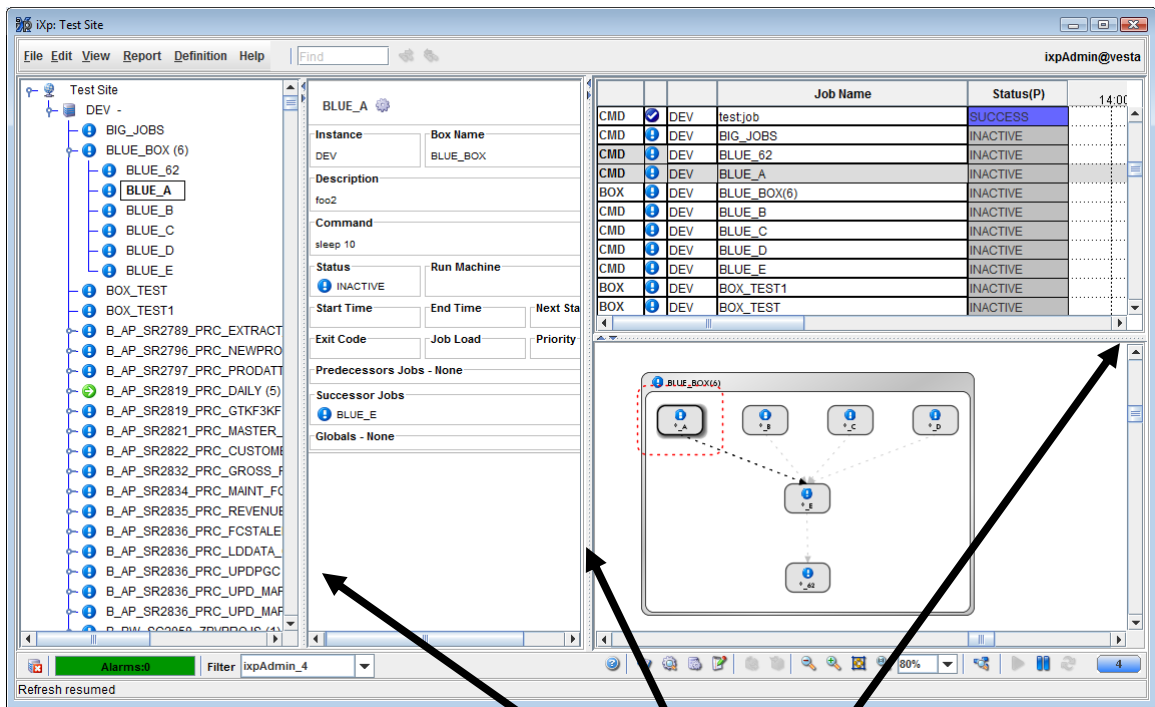

Window Size Adjusters

3.2 Graphical Views

There are five graphical views in iXp. Each view shares context with all the other views. All the views show the same data. The five views are as follows:

1. *Tree View*
2. *Job Detail View*
3. *Console View*
4. *Time View*
5. *Job Flow View*

3.3 The Console View

The **Console View** provides an ordered list of jobs and their vital details.

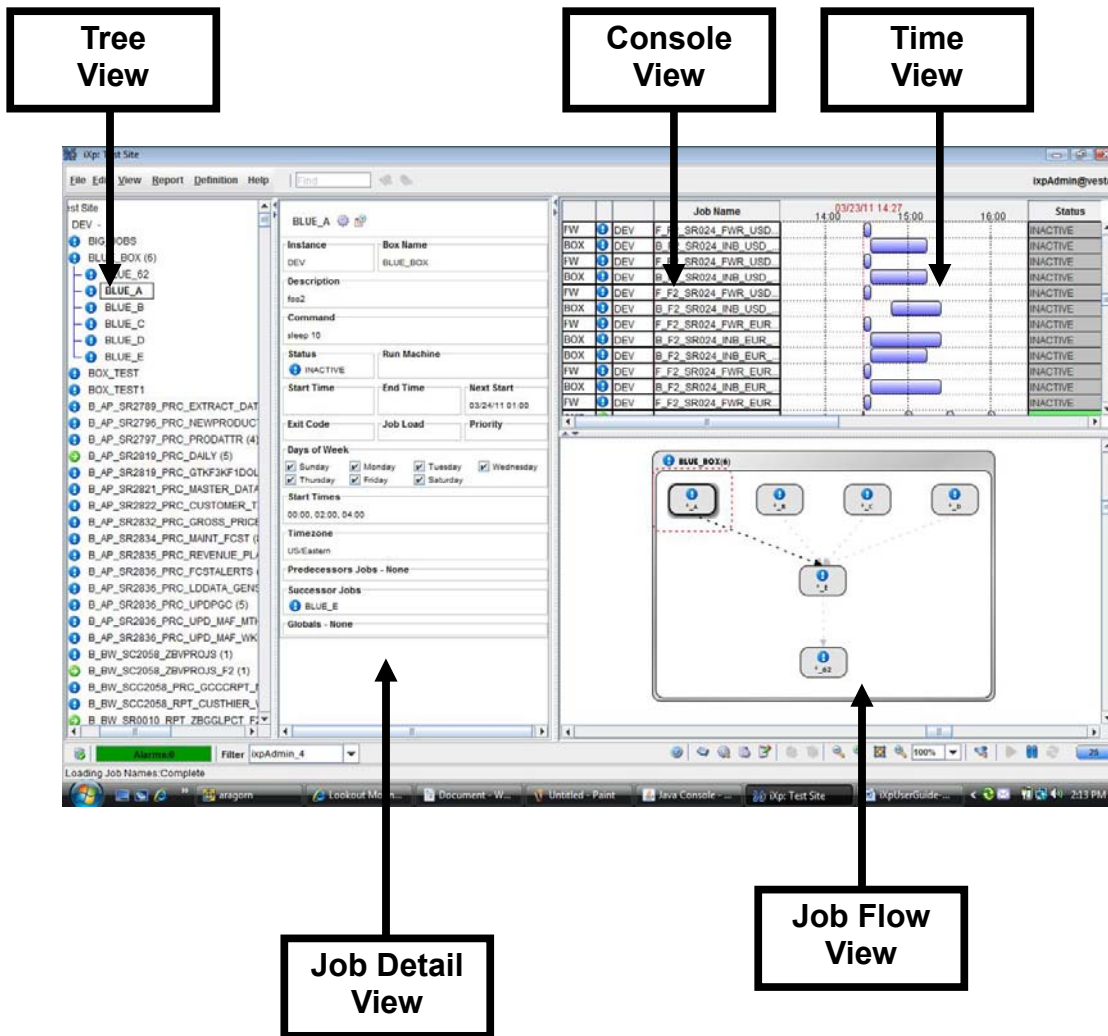

























COLUMN NAME	DESCRIPTION
(Job Type)	Job Type: CMD, BOX, FW, or new r11.3 job type
(Icon)	Shows the type of job or its state.
(Instance)	The 3 letter CA Workload Automation AE instance that contains the displayed job.
Job Name	The job name, a CA Workload Automation AE attribute.
Status	Displays the most current job status with its defined color,
<i>Time View</i>	A Gantt chart that shows past and future job runs based on the Past Hours and Future Hours settings for the user. The future job runs are based on the real-time forecast performed by the iXp Server.
Run Machine	The name of the physical machine that the job last ran on or is currently running on.
Start Time	The time the job last started.
End Time	The time the job last ended.
Duration	Duration is (End Time – Start Time), accurate to seconds.
Next Start	This column displays the next start date/time for jobs that are defined with date conditions.
Estimated End Time	For currently running jobs, this column displays the forecasted end time as calculated by the iXp Server

The column widths in the Console View may be adjusted, for example to read the entire start time, by dragging the edges of the column heading labels (e.g. “Start Time”) with the left mouse button.

The order of the columns can be modified by dragging them individually to the desired positions. The order of the first four columns that show the job type, job icon, instance and job name respectively, cannot be changed. These columns are locked in size and position. They can be unlocked, only for resizing, from the [Lock Job Name Column](#) check box on the View menu.

Each job row has an icon that indicates the status of the job. The icon meanings are shown below (use the Graphics Help selection on the Help menu in the iXp GUI):

The Console View

Status Icons	
	A job with a status of ACTIVATED
	A job with a status of FAILURE
	A job with a status of TERMINATED
	A job with a status of INACTIVE
	A job with a status of ON_HOLD
	A job with a status of ON_ICE
	A job with a status of RUNNING
	A job with a status of STARTING
	A job with a status of RESTART
	A job with a status of SUCCESS
	A job with a status of WAIT_REPLY
	A job with a status of QUE_WAIT
	A job with a status of PEND_MACH
	A job with a status of RESWAIT
	The job has an out-of-box predecessor or successor
	The job has an one-time override defined
	The job references a global variable in its condition or its command calls sendevent with -E SET_GLOBAL
	The job has predecessors or successors that are not in the current view
	A "success" dependency that has been satisfied, that is, the predecessor job has a status of SUCCESS .
	A "success" dependency that has not been satisfied, that is, the predecessor job has not gone to SUCCESS status.
	A "failure" or "terminated" dependency that has been satisfied, that is, the predecessor job has a status of FAILURE or TERMINATED .
	A "failure" or "terminated" dependency that has not been satisfied, that is, the predecessor job does not have a status of FAILURE or TERMINATED .
	A dependency of any other type (NOTRUNNING , DONE , EXITCODE) which has been satisfied. That is, the predecessor job is currently in one those states.
	A dependency of any other type (NOTRUNNING , DONE , EXITCODE) which has not been satisfied. That is, the predecessor job is not currently in one those states.
	A red dashed line is used to outline a selected job.

3.3.1 Time View

The Time View displays the past and forecasted job runs for all jobs listed in the Console View.

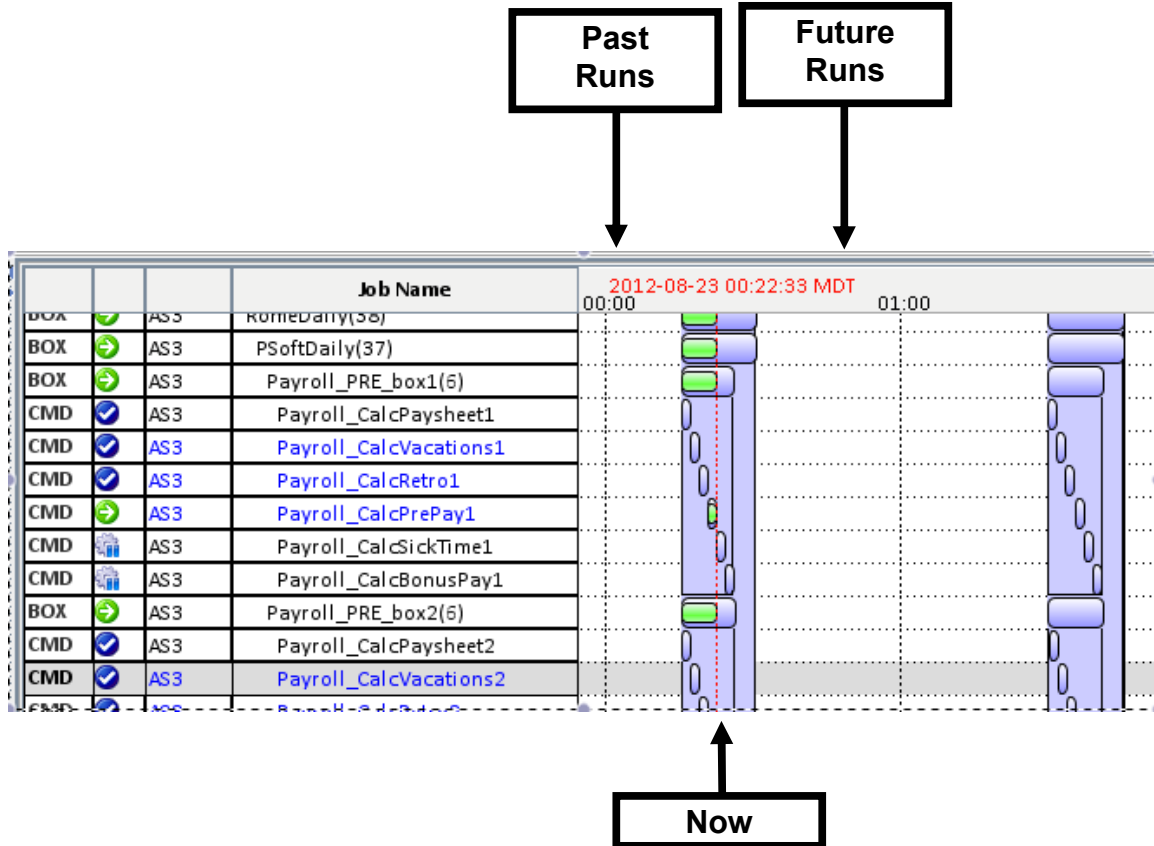

The job runs are displayed as colored rectangular bars, where the boundaries of the bars are based on start and end times of that run. The color of the bar indicates the completion status of the run. For forecasted runs, this would always match the color for a successful run. The colors can be edited by accessing the [Preference Editor](#) dialog. A smaller solid bar within the boundaries of the job run shows the progress of currently running jobs. The color of that bar matches the color of the RUNNING status. If the job has been running much longer than average, the color of that bar turns red. If the job has not run beyond its average duration, the distance between the end of the solid bar and the end of the job run boundary shows the estimated time left for the completion of the job.

The Time View has vertical line markings by the hour and the current time is displayed in red with a vertical red line going down the view. All job runs shown to the right of the red line of the current time are the forecasted runs.

The iXp Server generates a real-time forecast for all the configured CA Workload Automation AE instances. To generate an accurate forecast, the iXp Server takes into account the current statuses of all the jobs, all of the job dependencies,

date/time conditions and the average job durations as stored in the CA Workload Automation AE database. The iXp Server performs a forecast of each CA Workload Automation AE instance as per their forecasting properties listed in the *AdminTool*. The iXp Server also accounts for all the major CA Workload Automation AE latencies and hence the duration for forecasted runs may be greater than the average job duration which does not account for any latencies. If a past job run lasted much longer than the average duration for that job, the job run is marked with a red 'X' in the Time View. This provides a visual alert on all job runs that lasted longer than average.

Jobs that run much longer than scheduled, or are predicted to run much longer than scheduled, are also marked with a red X.

3.3.1.1 Setting Chart Duration

Use the “Past Hours” and “Future Hours” settings in the *Preference Editor* to set the duration of the Time View chart. For example, by setting the Past Hours and Future Hours to 2 Hours, the Time View would depict any runs within the last two hours for the jobs in the Console View and also show all forecasted runs for the next two hours for the same jobs.

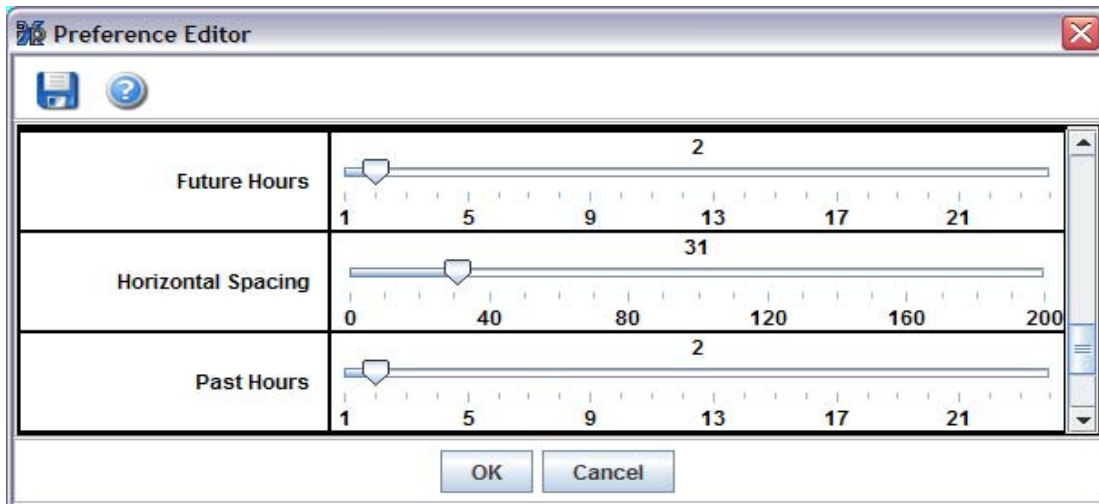

Use the “Time Window” tab in the *Filter Editor* to select jobs to be displayed according to their past and future run times. For example, adjusting “Past Hours” to 2 and “Future Hours” to 10, *in the Filter Editor*, and then applying the resulting filter, will contain jobs that have run in the past 2 hours, are currently running, or are forecasted to run in the next 10 hours. Adjusting the Time Window in the Filter Editor does not affect the Time View Chart duration set in the Preference Editor.

3.3.1.2 Retrieve Run Data

If the “**Retrieve Run Data**” box is not checked, no job run data will be displayed and hence the Time View would not show any runs. In order for the client to display past and forecasted job runs, the “Retrieve Run Data” box **MUST** be checked.

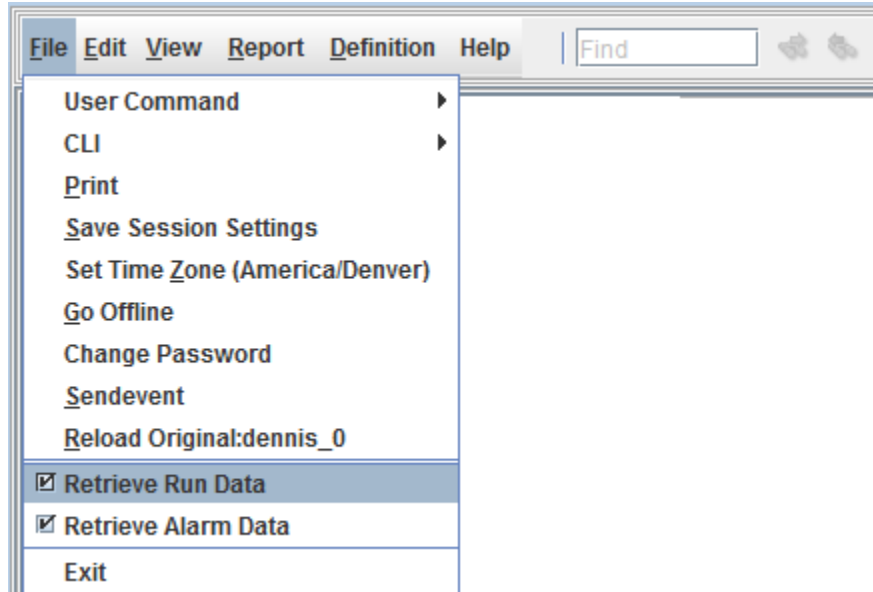

3.3.2 Sort Order in Console View

Rearrange the listing order in the Console View by selecting on a column heading with the right mouse button. The sort order selection (box) popup will appear:

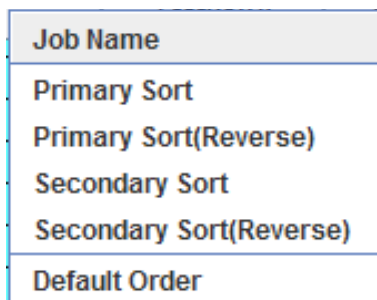

If no sort order is selected, and if there are no open ALARMS for any of the jobs in the Console View, then the jobs will be displayed in the **Default Order**, which is a hierarchical sort order, very similar to the Tree View.

If any of the jobs in the Console View has even one Open Alarm, then that job would be listed at the top of the view. If multiple jobs have Open Alarms, then those jobs will be sorted by the time the Alarm was generated, with the job with

The Console View

the most recent Alarm at the top. As soon as all the Open Alarms for such a job have been Acknowledged or Closed, the job would move to its default position.

The Console View allows users to specify primary and secondary sort criteria. For example, jobs could be sorted first by Job names and then by Start Times.

Sorting by Status gives the following order:

- FAILURE/TERMINATED
- RESTART
- QUE_WAIT
- PEND_MACH
- RESWAIT
- WAIT_REPLY
- STARTING
- RUNNING
- ACTIVATED
- ON_HOLD
- ON_ICE
- SUCCESS
- INACTIVE

3.4 Job Flow View

The **Job Flow View** shows the predecessor and successor job relationships for each job as well as the box hierarchy.

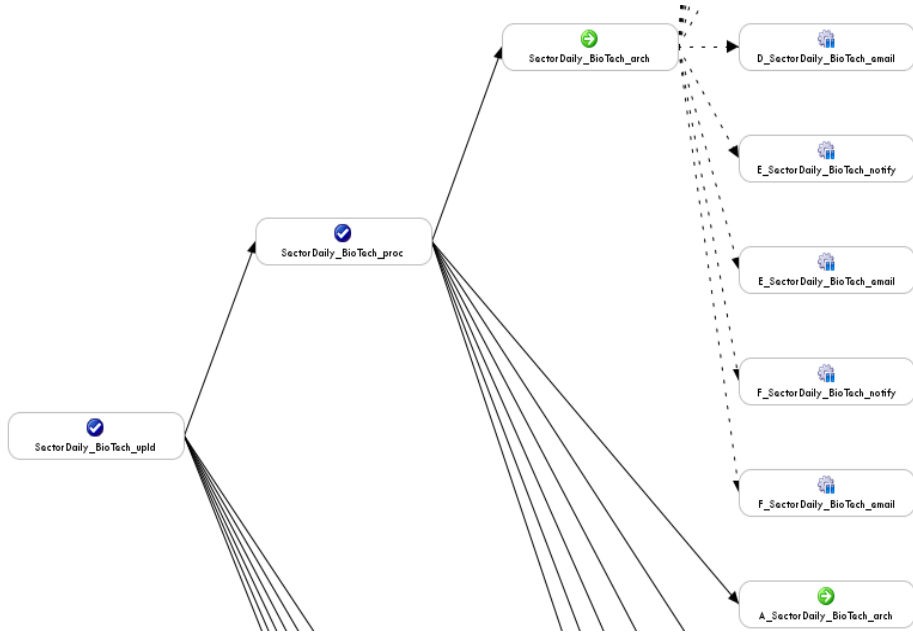

Left mouse-click on a job in the Job Flow View to highlight that job in black, and highlight its predecessor and successor relationship arrows. All other jobs and arrows will be grayed out. Once a job is selected, any right-click actions will affect that job.

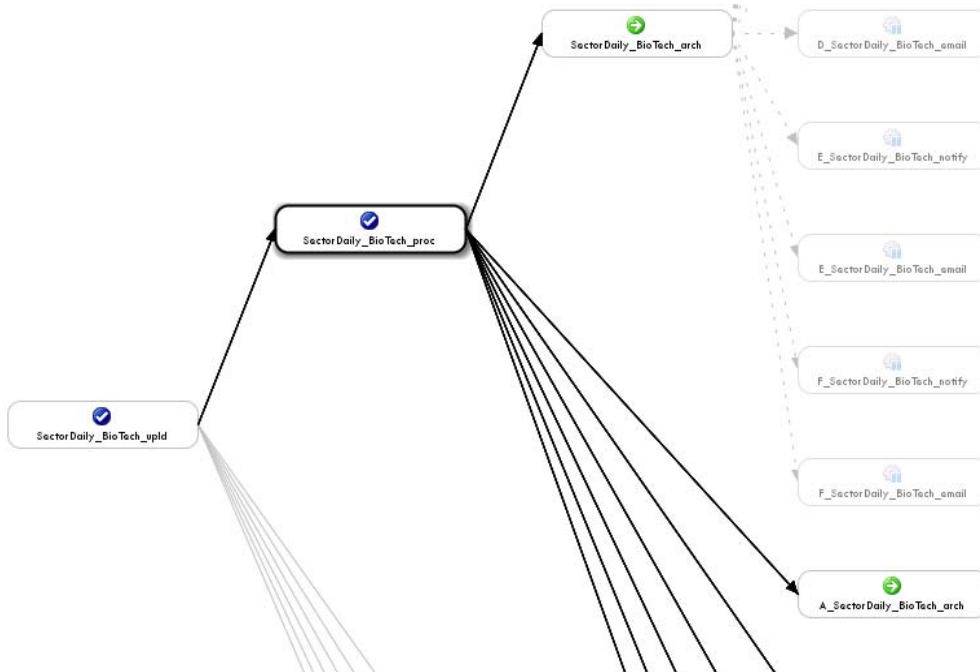

3.4.1 Zoom



Use the **Zoom** buttons on the iXp toolbar to adjust the size of the Job Flow View.

Fit  sizes the Job Flow View to show the entire structure. Zoom value of 100%

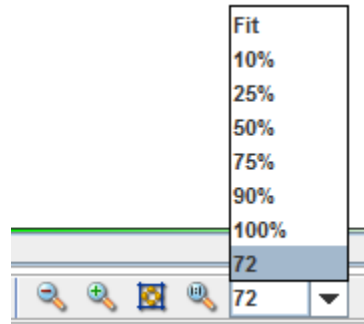
 gives a font size for the Job Flow View about equal to the other view fonts.



The default sizing layout in the Job Flow View (Zoom 100%) is derived from the job name font, horizontal spacing, and vertical spacing as set in the preferences (see the [Edit Preferences](#) Section of this document).

Other sizing options are the  and  icons on the Flow View Toolbar, as well as the “rubber-band” function—use the mouse to select an area that you want to view in more detail (this works best when refresh is paused). Finally, it is possible to simply type numbers into the zoom pull-down area.

Job Flow View

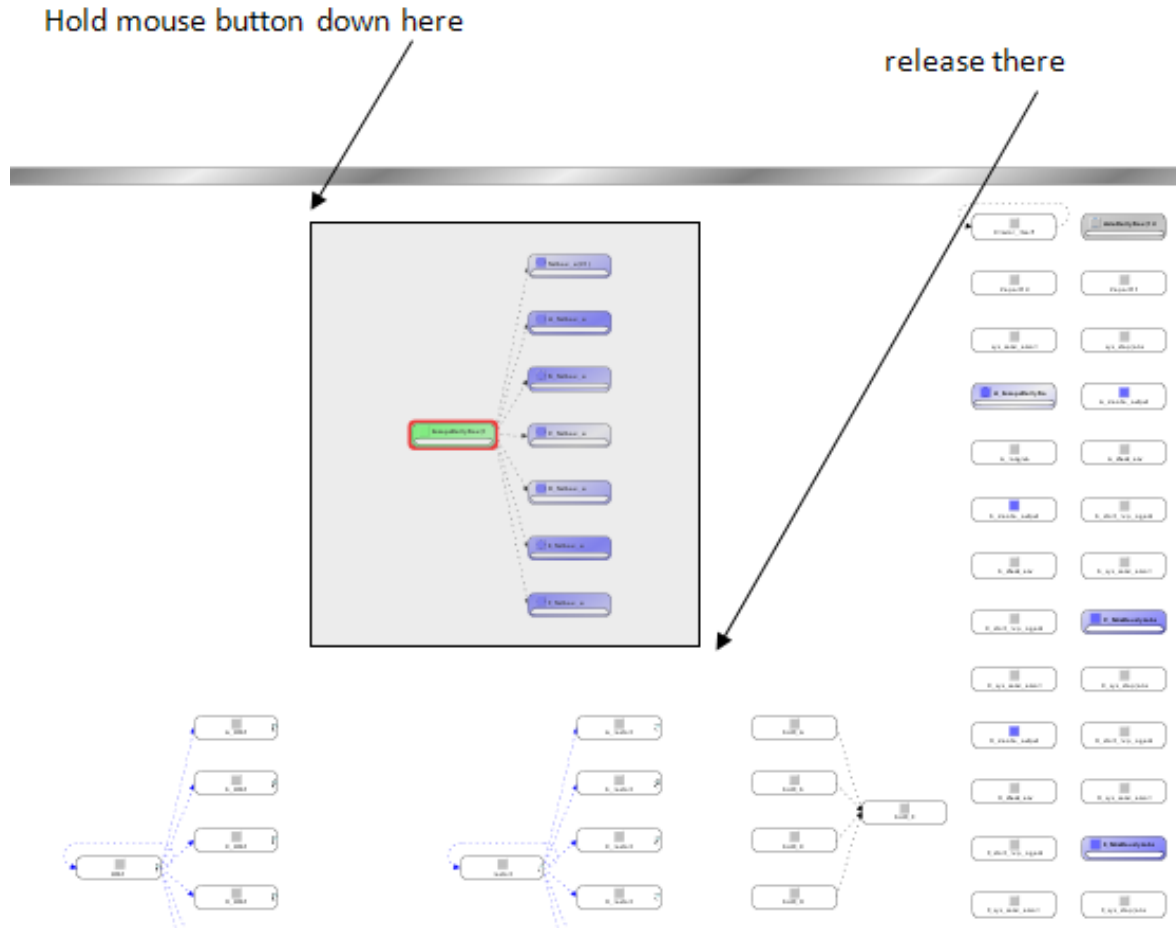

3.4.2 Job Flow View Order

In the Job Flow View, the jobs are arranged in the following ways:

1. Largest jobstreams (set of related jobs—jobs in boxes and jobs that depend on each other) at top left.
2. Smaller jobstreams are spaced across the top (or side if streaming top to bottom). Additional jobstreams are centered under each jobstream in the top row.
3. All jobs with no dependencies are grouped together
4. All other things being equal (size, number and position of predecessors, number and position of successors, how many jobs occur between the two compared jobs), jobs with a higher JOID (i.e. jobs that were defined later) will be below or to the right of jobs with lower JOIDs.

Jobs that are contained in the same box or Level-0 jobs, once they have been grouped, are positioned using the following criteria:

- size of job or box
- number and position of predecessors

Job Flow View

- number and position of successors
- the presence of out-of-box predecessors or successors
- the presence of circular dependency logic

If all the listed criteria are equivalent for two jobs in the same box, a job with a higher JOID (i.e. jobs that were defined later) will be below or to the right of a job with a lower JOID.

The *Stream Jobs* option on the View menu can be used to toggle between a left to right job flow and a top to bottom job flow.

3.4.3 Names in Job Flow View

In the Job Flow View, job names can be abbreviated in several ways. This preserves View space in the event of commonly used naming practices. The abbreviation functions are as follows:

- 1) Truncate Job Names, based on shared prefixes of sibling jobs existing on the iXp Client. Example: jobs named abc101 and abc102 are abbreviated to *1 and *2. The three characters (., _ and –) are special delimiter characters, and are kept in the abbreviated job names. Example: abc.101 and abc.102 are abbreviated as *.101 and *.102.
- 2) Keep First 8 letters, which is a simple numerical cut of everything from character 9 on.
- 3) Hide Job Names, which reduces each job to an icon.
- 4) Show Job Names displays the entire job name for each job.

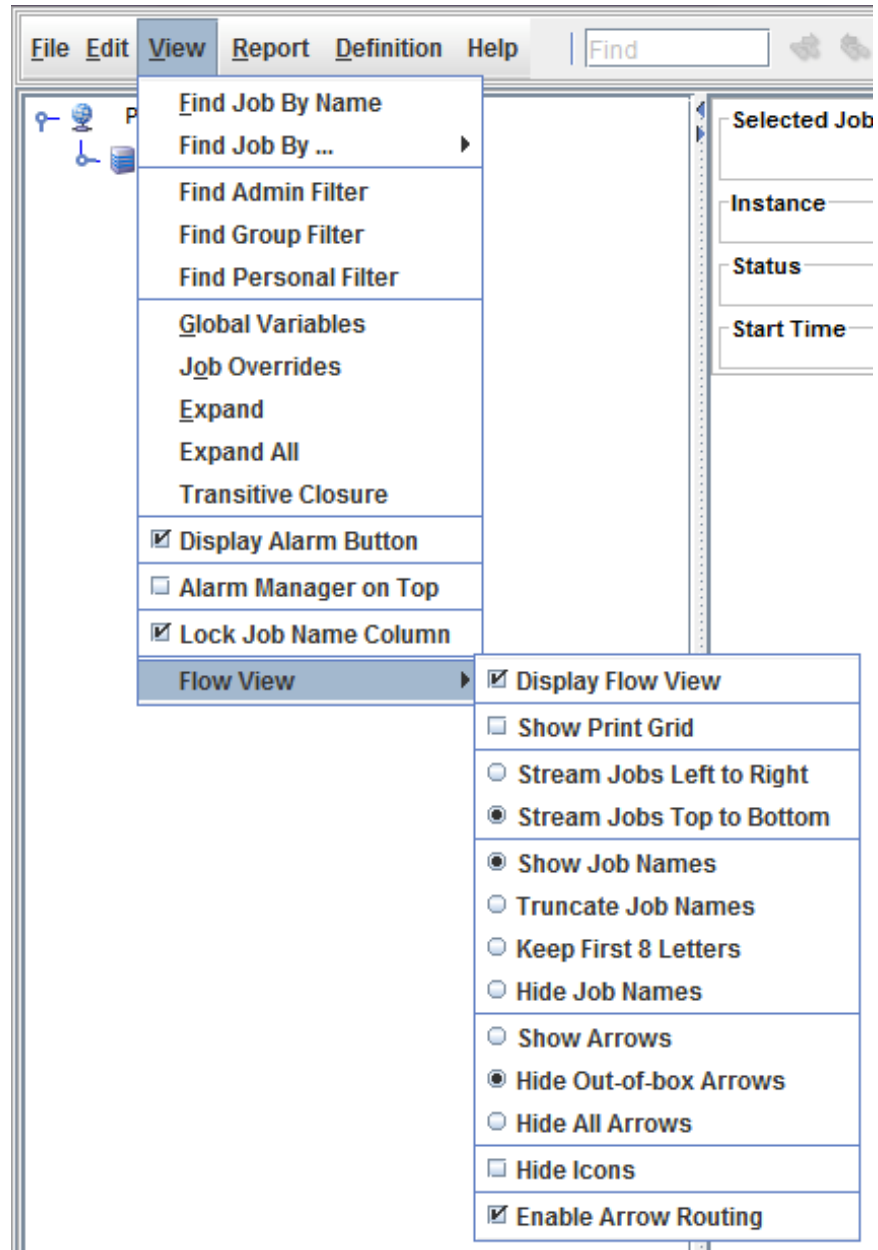

These options are accessed on the View menu, using the Flow View sub-menu.

3.4.4 Global Variable Symbol

Jobs that have dependency relationship on a *Global Variable* show a white “map pin” in the upper-right corner. This indication is shown for two kinds of jobs.

- 1) Jobs that have an explicit dependency on one or more global variables, as defined in their starting conditions.

Job Flow View

- Jobs that set the value of one or more global variables. The appropriate sendevent syntax for setting global variables must be defined in the command field.



Basic	
AS1	Job Name Testbox_a_4
	Box Name Testbox_a
	Owner autosys@aragorn
Job Type <input type="radio"/> Command <input type="radio"/> Box <input checked="" type="radio"/> File Watcher	
Description	filewatcher job for a file
Condition	v(RESTART)=Y
Watch File	/install/CA/UnicenterAutoSysJM/autosys/bin/zql
Machine	aragorn

3.5 The Job Detail View

The **Job Detail View** shows details of the selected job:

The screenshot shows a detailed view of a job named 'EuropeDailyBox'. The interface includes several sections:

- Instance:** STR
- Box Name:** N/A
- Description:** This box job contains the daily processes for the European Region.
- Condition:** s(AsiaDailyBox) and v(OKTORUN)= YES
- Status:** SUCCESS (indicated by a blue checkmark icon)
- Run Machine:** N/A
- Start Time:** 2010-03-30 03:30:32 MDT
- End Time:** 2010-03-30 03:45:07 MDT
- Next Start:** 2010-03-30 04:15:00 MDT
- Days of Week:** All days from Sunday to Saturday are selected with checkmarks.
- Start Times:** 04:15, 10:30
- Predecessor Jobs:** SUCCESS (green checkmark) and AsiaDailyBox (blue checkmark).
- Successor Jobs:** Testbox_a (blue checkmark) and FranceDailyBox (blue checkmark).
- Globals:** OKTORUN=YES (globe icon).

Detail View Item	Description
Selected Jobs	Lists the jobs that have been selected in the Console View, the Job Flow View, or the Tree View. If more than one job is selected, only the selected job names will appear; the remaining fields in the Detail View will be blank.
Instance/icons	The name of the CA Workload Automation AE

The Job Detail View

	Instance where this job is defined, and icons that provide detail about the job. In the example above, the icons show that this is a Command (rather than Box or Filewatcher) job, that it has date/time conditions, that it has a dependency, and that it uses a Global Variable.
Box Name	The name of the Box Job that contains the selected job. Jobs that are not in boxes will show N/A.
Description	The contents of the CA Workload Automation AE JIL description attribute.
Command / Watch File	The contents of the CA Workload Automation AE JIL command attribute to be executed for command jobs, and may be the name of any command, executable, UNIX shell script or batch file, and its arguments. If the job is a Box Job, this field is not shown. If the job is a File Watcher, then the contents of the CA Workload Automation AE JIL <code>watch_file</code> attribute is shown.
Condition	The contents of the CA Workload Automation AE JIL <code>condition</code> attribute which specifies when the job can or cannot run relative to other jobs. If this attribute is blank, then this field is not shown.
Status, Machine, Start Time, End Time, and Next Start	The same attributes as described for the Console View.
Exit Code	The exit code returned by the operating system for the most recent run of the job.
Job Load	The CA Workload Automation AE JIL <code>job_load</code> attribute data; default value is 0 if not defined. This field is not shown for Box jobs.
Priority	The CA Workload Automation AE JIL <code>priority</code> attribute data; default value is 0 if not defined. This field is not shown for Box jobs.
Days of Week/Run Calendar	The CA Workload Automation AE JIL <code>days_of_week</code> or <code>run_calendar</code> attribute of the selected job. If this attribute is not defined, then this field is not shown.

The Job Detail View

Exclude Calendar	The CA Workload Automation AE JIL <code>exclude_calendar</code> attribute of the selected job.
Start Times / Start Mins	The CA Workload Automation AE JIL <code>start_times</code> or <code>start_mins</code> attribute of the selected job. If this attribute is not defined, then this field is not shown.
Timezone	Displays the CA Workload Automation AE JIL <code>timezone</code> attribute of the selected job. If this attribute is not defined, then this field is not shown.
Run Window	The CA Workload Automation AE JIL <code>run_window</code> attribute of the selected job. If this attribute is not defined, then this field is not shown.
Predecessor Jobs	<p>The predecessors to the selected jobs, as seen in the Job Flow View. A checkbox in front of the predecessor job name indicates whether the condition between that job and the selected job has been met or not.</p> <p>Selecting a job in the Predecessor Jobs list will highlight that job in all the views, including the Job Detail View. This is one way to easily trace through job dependency relationships.</p>
Successor Jobs	<p>The successors to the selected job, as seen in the Job Flow View. Each successor job is listed with an icon that shows its current status.</p> <p>Selecting a job in the Successor Jobs list will highlight that job in all the views, including the Job Detail View. This is one way to easily trace through job dependency relationships.</p>
Global Variables	If the selected job is dependent upon Global Variables , or is setting the value for any, then the current value of the global variable(s) will be displayed here.

If any of the following attributes are displayed, you can click on the values shown to perform the associated actions.

Attribute	Associated Action
Run Calendar	View the calendar dates in the graphical Calendar

The Job Detail View

	dialog.
Exclude Calendar	View the calendar dates in the graphical Calendar dialog.
Predecessor Job	Change the selection to the job that was clicked.
Successor Job	Change the selection to the job that was clicked.
Global Variable	Launch the Global Variable dialog to view the list of jobs associated with the clicked Global variable, set the value or delete the Global variable.

The following screen shows the atomic conditions being displayed in the Detail View. If a dependency has been met, then the Predecessor jobs field shows a checkmark for that job.

The condition attribute of the selected job.

Payroll_CalcPay_box 🏠 🗨️

Instance	Box Name
STR	PSoftDaily
Condition	
s(Payroll_PRE_box1) & s(Payroll_PRE_box2) & s(Payroll_PRE_box3) & s(Payroll_PRE_box4)	
Status	Run Machine
🏠 ACTIVATED	N/A
Start Time	End Time
	Next Start
Predecessor Jobs	
✅ SUCCESS	🔵 Payroll_PRE_box1
✅ SUCCESS	🔵 Payroll_PRE_box2
✅ SUCCESS	🔵 Payroll_PRE_box3
❑ SUCCESS	🟢 Payroll_PRE_box4
Successors Jobs - None	
Globals - None	

The indicator whether the above conditions have been met or not.

Predecessor Jobs

- ✅ SUCCESS 🔵 Payroll_PRE_box1
- ✅ SUCCESS 🔵 Payroll_PRE_box2
- ✅ SUCCESS 🔵 Payroll_PRE_box3
- ❑ SUCCESS 🟢 Payroll_PRE_box4

3.6 The Tree View

The **Tree View** depicts the hierarchical box structure of the jobs. Box Job icons look like a box and open when the Tree View displays the jobs contained in the Box Job. Left-mouse-click on the knob next to a Box Job or double-click on the box to expand one level and show the contents of the Box Job in the Tree View

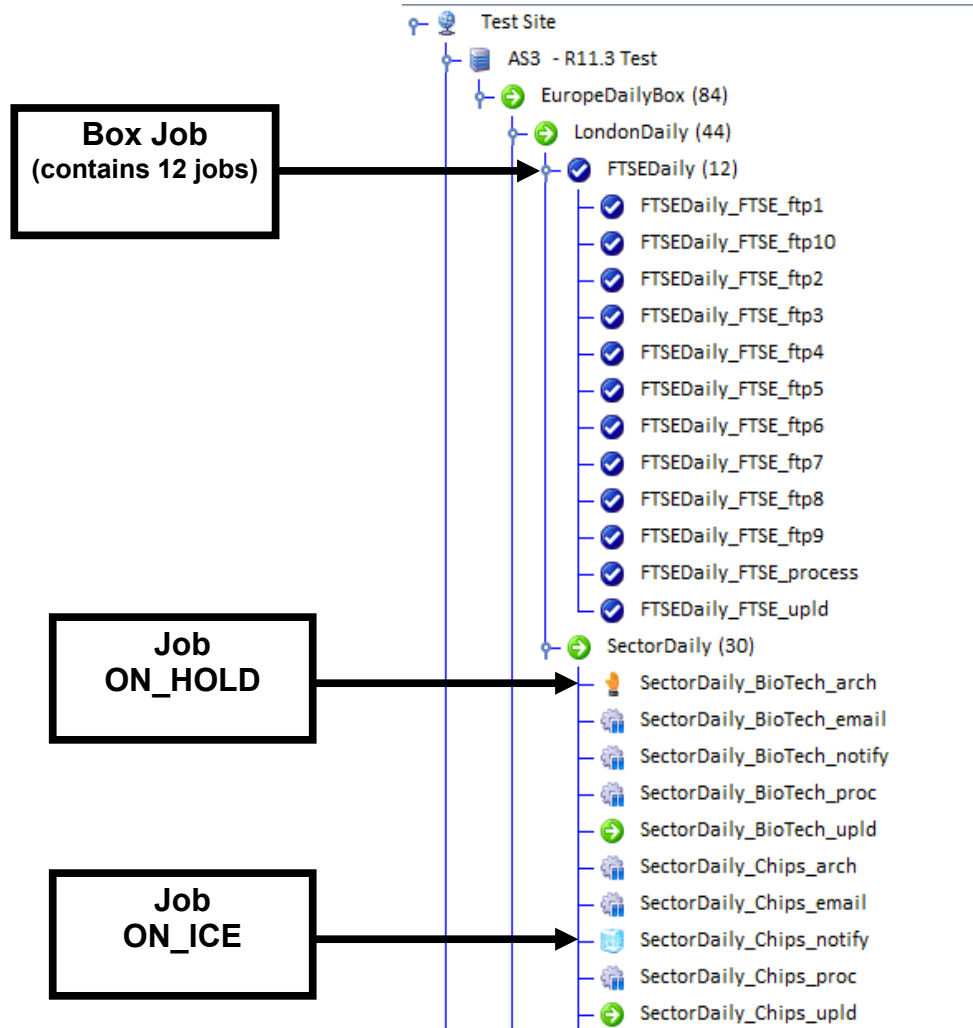







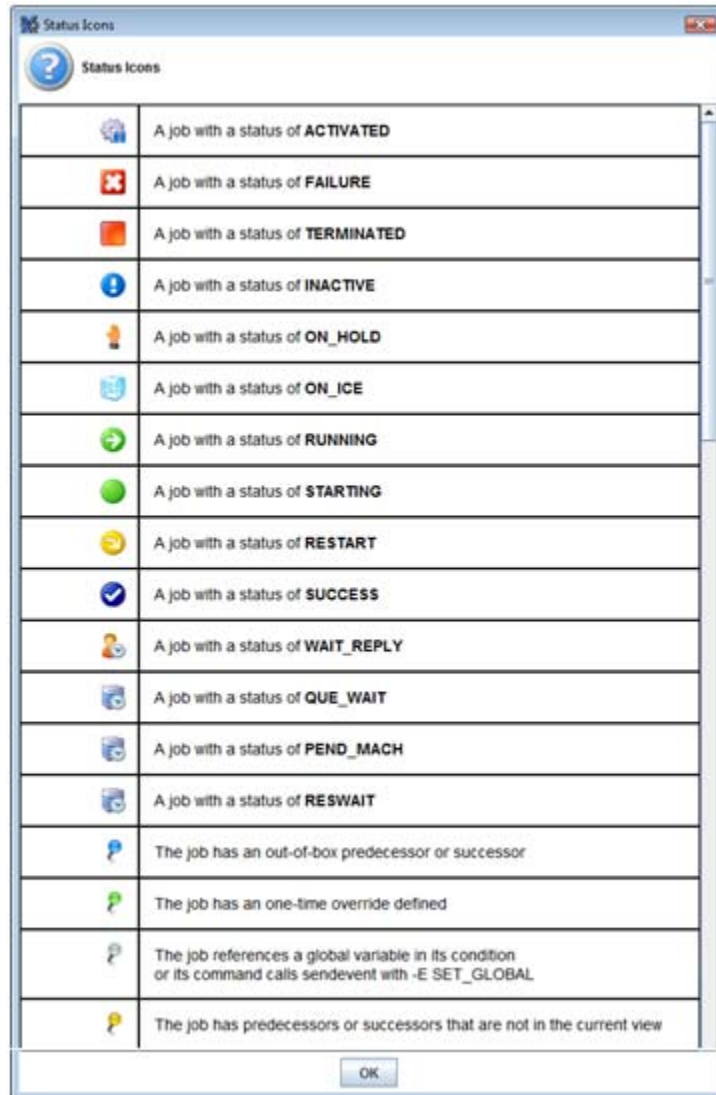











Use the right mouse button to select **Expand** to expand the view one level, or **Expand All** to view the entire Tree View. The Expand or Expand All option can be applied to a Box Job, an Instance or the whole Site. Expanding a Box job shows all the jobs at the next level within the selected Box job. Expanding an instance shows all Level Zero jobs (i.e. all jobs that are NOT within a Box job), including top-level Box jobs. When an Expand All is performed, all jobs within the selected Instance or Box or Site are shown. This could result in quite a large number of jobs.

The Tree View

Each job has an icon that displays the status of the job. Icon meanings are listed on the Graphics Help page under the Help menu, as shown below:



Icon	Description
	A job with a status of ACTIVATED
	A job with a status of FAILURE
	A job with a status of TERMINATED
	A job with a status of INACTIVE
	A job with a status of ON_HOLD
	A job with a status of ON_ICE
	A job with a status of RUNNING
	A job with a status of STARTING
	A job with a status of RESTART
	A job with a status of SUCCESS
	A job with a status of WAIT_REPLY
	A job with a status of QUE_WAIT
	A job with a status of PEND_MACH
	A job with a status of RESWAIT
	The job has an out-of-box predecessor or successor
	The job has an one-time override defined
	The job references a global variable in its condition or its command calls sendevent with -E SET_GLOBAL
	The job has predecessors or successors that are not in the current view

3.7 Selecting Multiple Jobs

To select a job in any of the views, left-click the mouse on that job.

<Ctrl>left mouse-click adds jobs to those selected—two or more jobs at the same time—this applies in the Tree View, the Console View, and the Job Flow View.

Shown below is the Job Flow View, with 3 jobs selected:

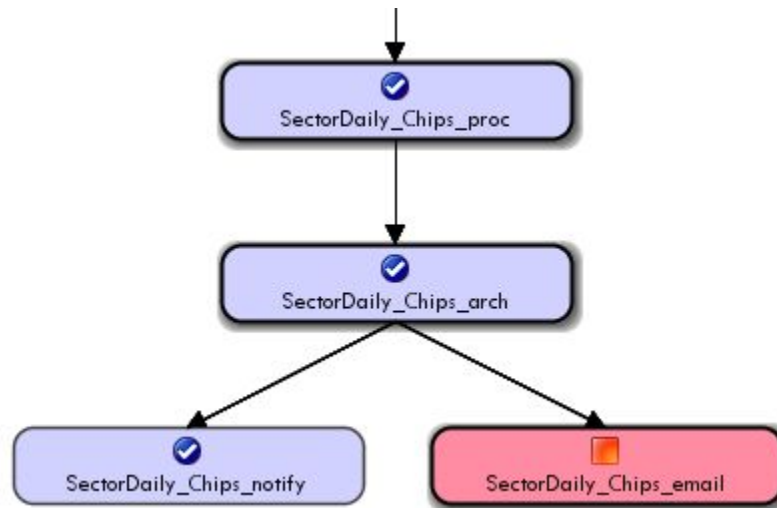

Here is a section of the Tree View, with the same jobs selected.

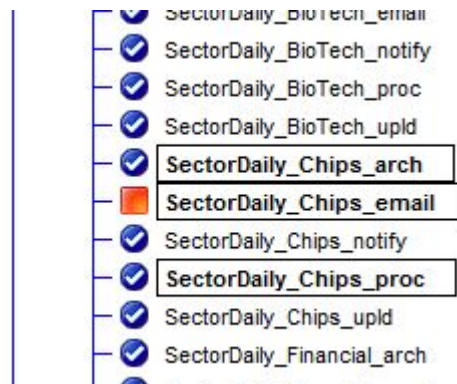

<Shift>left mouse-click selects all jobs between the two mouse click locations—this applies in the Tree View and the Console View.

Once jobs are selected, right mouse-click to bring up the **Job Tools popup** for all of the selected jobs. (See the [Job Tools](#) popup Section of this document.) Note that in multi-selected mode, right mouse-click does not bring up the Expand and Collapse selections of the menu.

File Menu:

4 iXp MENU BAR

4.1 File Menu:

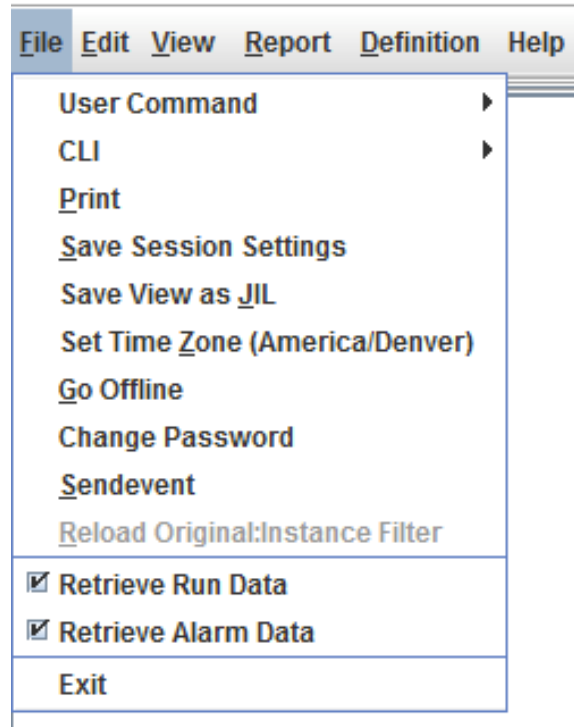

4.1.1 File►User Command

Select **File►User Command** to bring up the User Command pick list. This menu option is visible only if you are allowed to execute User Commands. You will only see those User Commands that are either shared globally, or shared with your group(s).

File Menu:

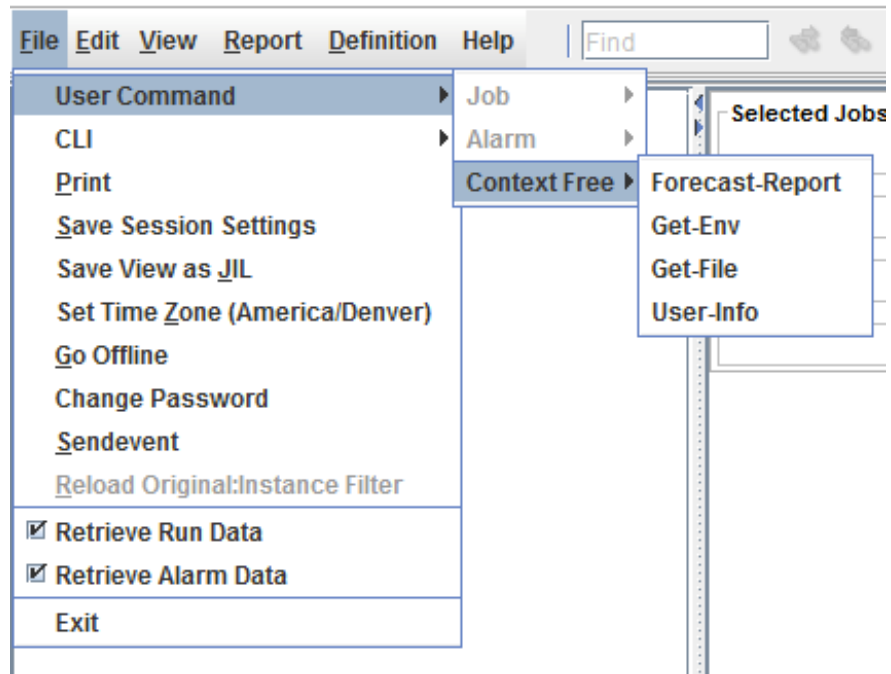

User Commands are created by the *iXp Administrator*. User Commands are a way for iXp to pass job data to existing UNIX or NT scripts, commands, or program interfaces on the iXp Server (see *example* in the Admin Tool Chapter of the *iXp Administration Guide*). Once User Commands are created, they appear on the pick list. When a User Command is run, iXp sets appropriate environment variables on the iXp Server, for the type of command, and then launches the specified command. See the list of environment variables in the *Admin Tool User Command* Section of the *iXp Administration Guide*.

By default, the user is required to confirm the execution of the User Command (this requirement may be disabled by the Administrator—in which case the command will execute immediately):

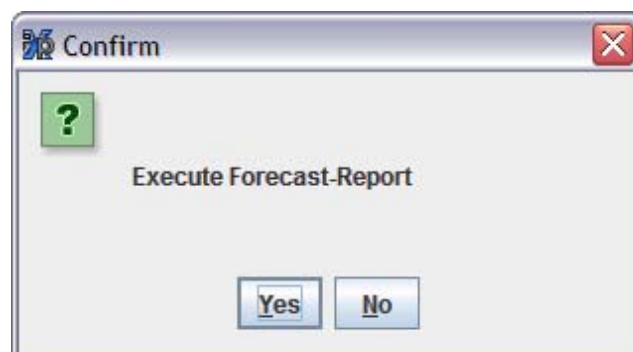

User Commands may require input from the user (again, as defined by the Administrator). If that is the case, the prompt will appear like this:

File Menu:

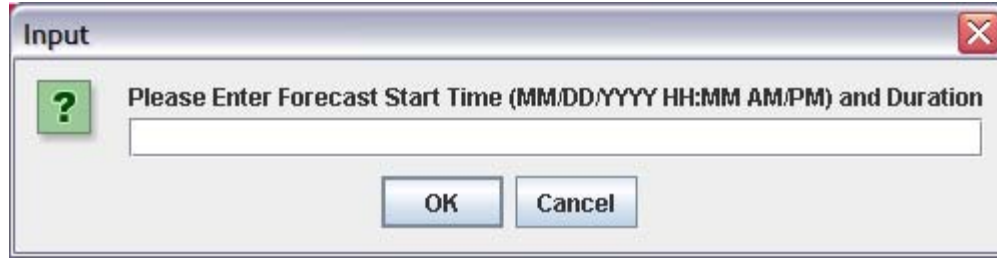

4.1.1.1 File ► User Command ► Job

User Commands of type **Job** may be run when a job is selected in the iXp views. Select "**Job**" to run a User Command of type Job, after selecting a chosen job in the iXp views. Job User Commands can ONLY be run when a job has been selected. If no job is selected, the Job User Command menu item will be grayed out. User commands can be setup such that users can select multiple jobs and then execute the same command on each of the selected jobs. If a User Command is executed on multiple jobs, iXp will run the user command on each job consecutively, and then show the concatenated output.

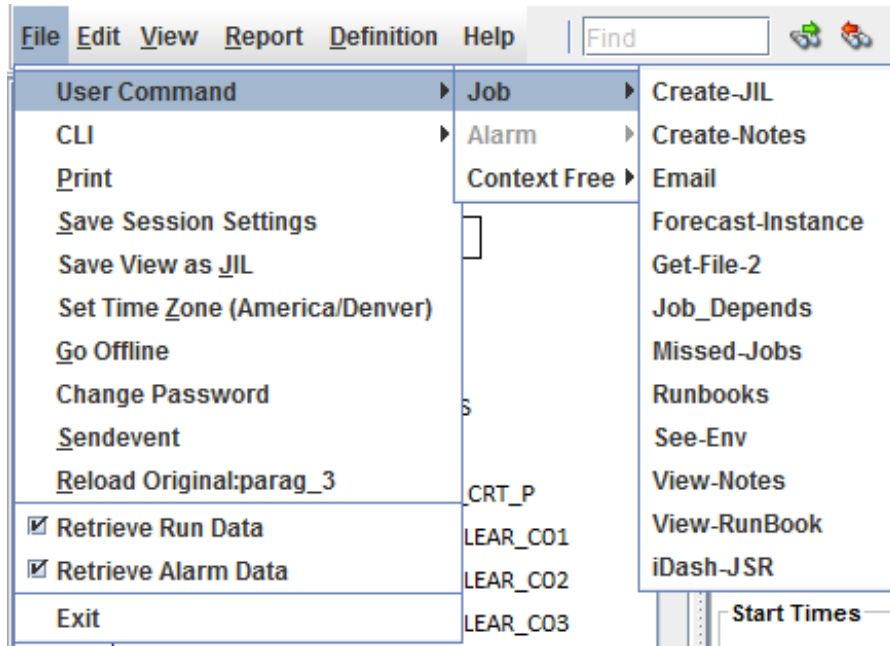

When a user command is executed, some relevant information about the selected job is set in the environment. The following example lists some of the environment variables that are set and their values.

```
IXP_HOME=/install/PGTI/ixphome
IXP_USERCOMMAND_INPUT_PROMPT=
IXP_USERCOMMAND_INPUT=
IXP_USERCOMMAND_JOB_JOID=757
IXP_USERCOMMAND_JOB_LAST_END=5/7/07 11:31 AM
IXP_USERCOMMAND_JOB_LAST_RUN_MACHINE=aragorn
IXP_USERCOMMAND_JOB_LAST_START=5/7/07 11:11 AM
```

File Menu:

```
IXP_USERCOMMAND_JOB_NAME=FTSEDaily_FTSE_process  
IXP_USERCOMMAND_JOB_STATUS=INACTIVE  
IXP_USERCOMMAND_USER_NAME=ixpAdmin  
ixp.home=/install/PGTI/ixphome
```

The results of any user command are shown in a web browser. This enables the user to leverage the functionality of the browser to save, print, email, or search the output.

4.1.1.2 File ► User Command ► Alarm

User Commands of type Alarm are available when an Alarm Job is selected in the *Alarm Manager*. The procedure to execute Alarm User commands is the same as that for Job User commands.

If a Job Alarm is selected in the Alarm manager, right-clicking on it will bring up the Alarm Pop-up menu, which includes Alarm User Commands. The Pop-up is not supported for other types of alarms (Rollover, etc.).

4.1.1.3 File ► User Command ► Context Free

For User Commands of type Context Free, the iXp Request Server executes the command without setting any job or alarm specific information. To run context free commands, it is not required to click and select a job or an alarm. Two default context free user commands are supplied with iXp:

Forecast_Next_48hrs
Forecast_Next_24hrs.

The Forecast_Next_24Hrs and the Forecast_Next_48Hrs commands provide a text report of all the forecasted runs in the next 24 and 48 hours respectively.

File Menu:

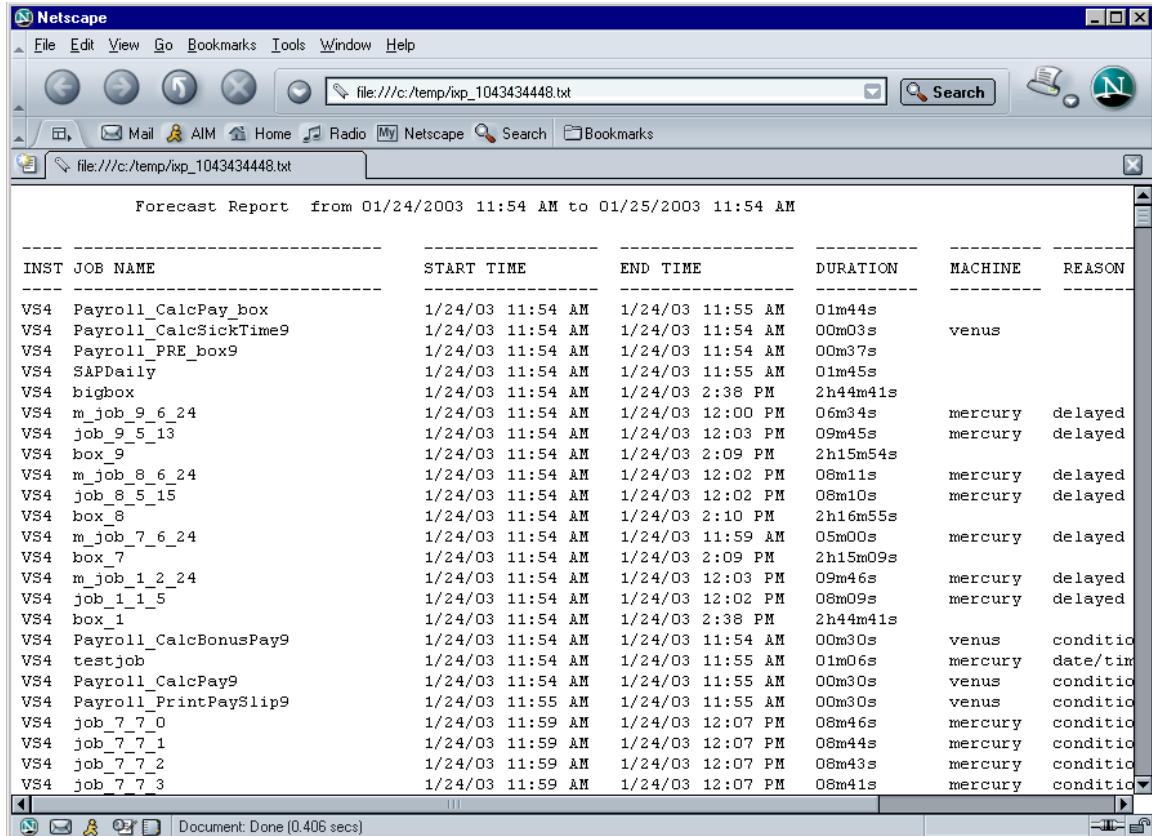

Forecast Report from 01/24/2003 11:54 AM to 01/25/2003 11:54 AM

INST	JOB NAME	START TIME	END TIME	DURATION	MACHINE	REASON
VS4	Payroll_CalcPay_box	1/24/03 11:54 AM	1/24/03 11:55 AM	01m44s		
VS4	Payroll_CalcSickTime9	1/24/03 11:54 AM	1/24/03 11:54 AM	00m03s	venus	
VS4	Payroll_PRE_box9	1/24/03 11:54 AM	1/24/03 11:54 AM	00m37s		
VS4	SAPDaily	1/24/03 11:54 AM	1/24/03 11:55 AM	01m45s		
VS4	bigbox	1/24/03 11:54 AM	1/24/03 2:38 PM	2h44m41s		
VS4	m_job_9_6_24	1/24/03 11:54 AM	1/24/03 12:00 PM	06m34s	mercury	delayed
VS4	job_9_5_13	1/24/03 11:54 AM	1/24/03 12:03 PM	09m45s	mercury	delayed
VS4	box_9	1/24/03 11:54 AM	1/24/03 2:09 PM	2h15m54s		
VS4	m_job_8_6_24	1/24/03 11:54 AM	1/24/03 12:02 PM	08m11s	mercury	delayed
VS4	job_8_5_15	1/24/03 11:54 AM	1/24/03 12:02 PM	08m10s	mercury	delayed
VS4	box_8	1/24/03 11:54 AM	1/24/03 2:10 PM	2h16m55s		
VS4	m_job_7_6_24	1/24/03 11:54 AM	1/24/03 11:59 AM	05m00s	mercury	delayed
VS4	box_7	1/24/03 11:54 AM	1/24/03 2:09 PM	2h15m09s		
VS4	m_job_1_2_24	1/24/03 11:54 AM	1/24/03 12:03 PM	09m46s	mercury	delayed
VS4	job_1_1_5	1/24/03 11:54 AM	1/24/03 12:02 PM	08m09s	mercury	delayed
VS4	box_1	1/24/03 11:54 AM	1/24/03 2:38 PM	2h44m41s		
VS4	Payroll_CalcBonusPay9	1/24/03 11:54 AM	1/24/03 11:54 AM	00m30s	venus	conditio
VS4	testjob	1/24/03 11:54 AM	1/24/03 11:55 AM	01m06s	mercury	date/tim
VS4	Payroll_CalcPay9	1/24/03 11:54 AM	1/24/03 11:55 AM	00m30s	venus	conditio
VS4	Payroll_PrintPaySlip9	1/24/03 11:55 AM	1/24/03 11:55 AM	00m30s	venus	conditio
VS4	job_7_7_0	1/24/03 11:59 AM	1/24/03 12:07 PM	08m46s	mercury	conditio
VS4	job_7_7_1	1/24/03 11:59 AM	1/24/03 12:07 PM	08m44s	mercury	conditio
VS4	job_7_7_2	1/24/03 11:59 AM	1/24/03 12:07 PM	08m43s	mercury	conditio
VS4	job_7_7_3	1/24/03 11:59 AM	1/24/03 12:07 PM	08m41s	mercury	conditio

4.1.2 File ► CLI

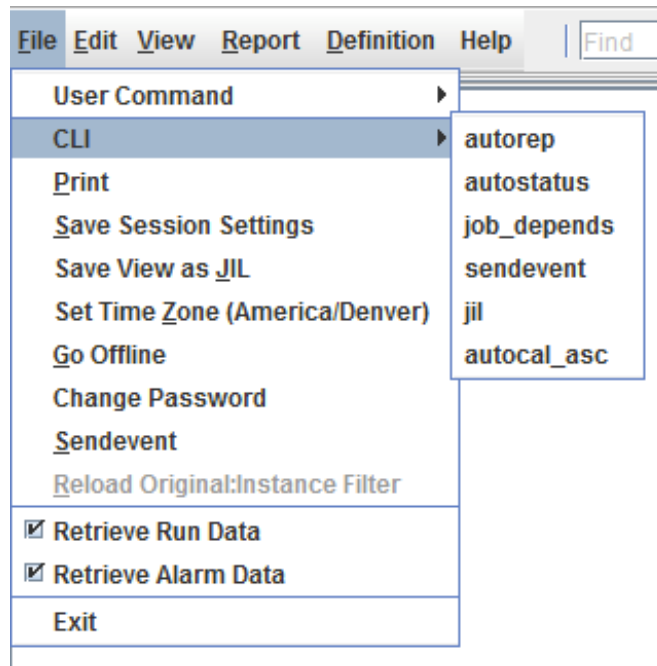

Select **File ► CLI** to execute Command Line utilities from the GUI. For example, to run an autorep command, select **File ► CLI ► autorep** as shown below.

File Menu:



For specifics regarding the command line options, click the **Usage** button.

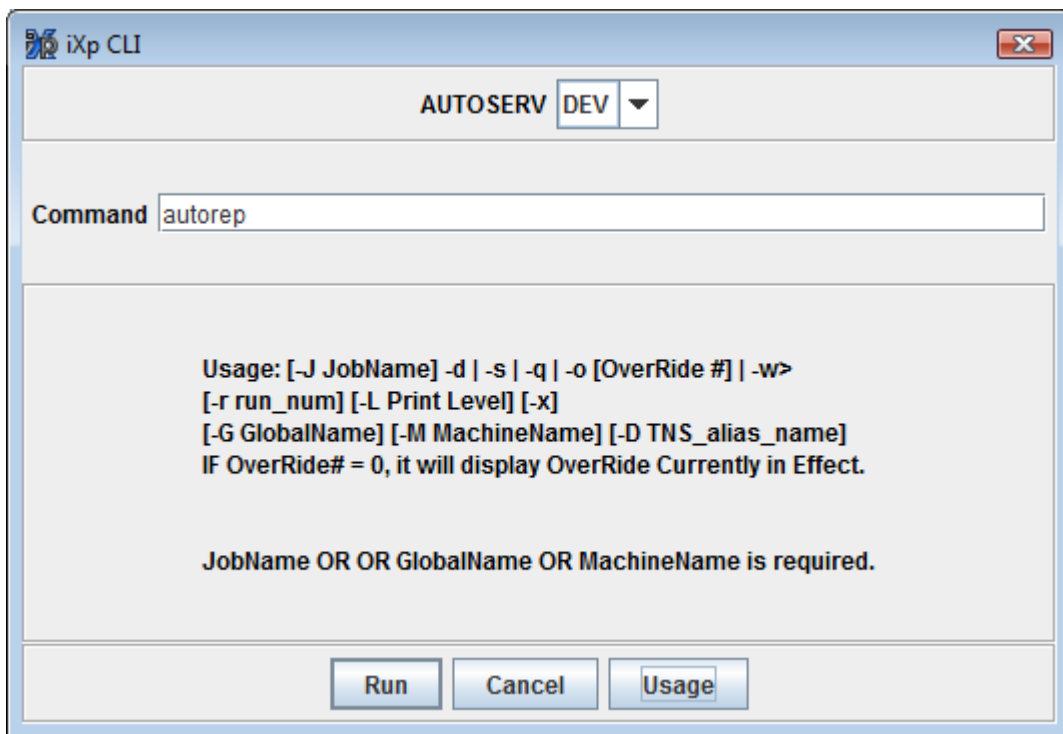

Supported commands are autorep, autostatus, job_depends, sendevent, jil. The user's security privilege setting will control what jobs and what actions are allowed.

The "jil" option is slightly different:

File Menu:

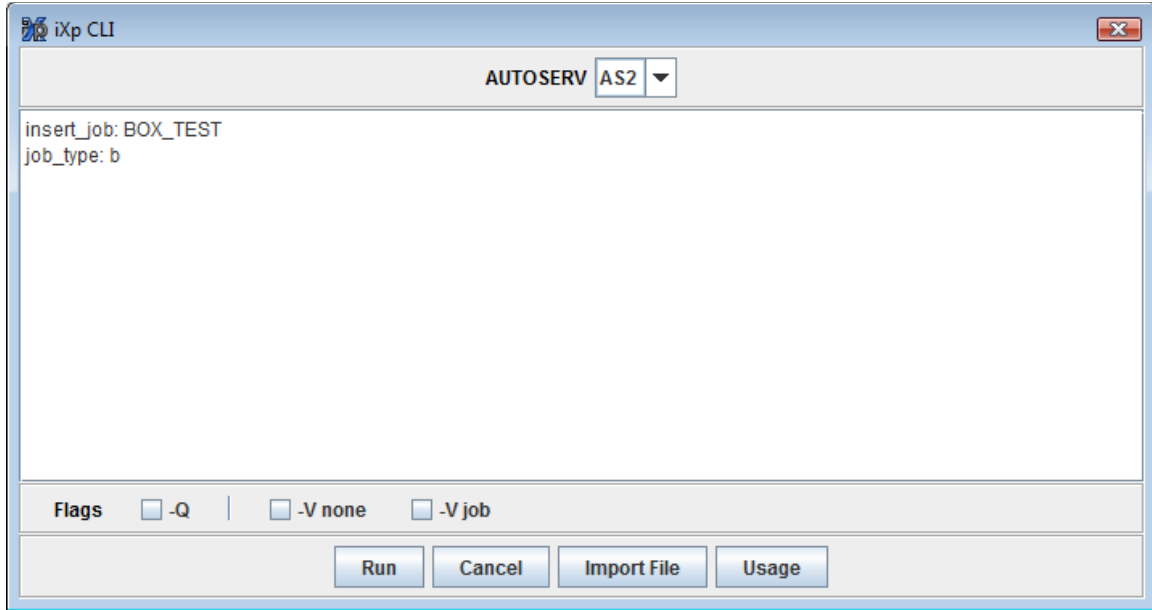

Options include the “quiet” (-Q) and verification (-V) check boxes as well as the **Import File** button.

4.1.3 File ► Print

Selecting **File ► Print** brings up the standard operating system Print window. This will print the Job Flow View, with paging controlled by the **Print Grid**. Check the [Show Print Grid](#), under the iXp View menu, to see the Print Grid in the Job Flow View window.

NOTE: The entire Job Flow View will be printed, not only what you see in the Job Flow View’s scrolling area.

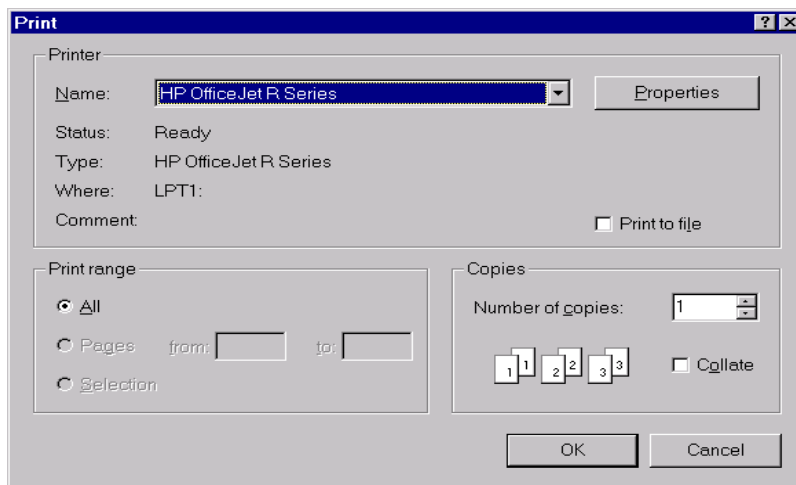

Adjust Properties for your printer, if you desire, and select “OK” to print the Job Flow View.

File Menu:

NOTE: The Print Dialog is provided by your underlying operating system and differs across platforms. The above graphic is a Windows NT® dialog.

Currently, the print size and print orientation is not configurable. Hence, the print size is always 8.5 x 11 inches, and in portrait orientation. If the print layout exceeds one page, iXp will print out the job flow across multiple pages.

4.1.3.1 Print Tiling

Multi-page prints are tiled, with tile row and column numbers printed in the lower left of the pages.

4.1.4 File ► Save Session Settings

This saves the user preferences to the iXp Server. Save Session Settings results in saving of the user preferences, as listed in the preference dialog, and the start-up filter setting, as dictated by the Current Filter. Also the current iXp windows layout, the size, position and sort order of columns in the Console View and the Alarm Manager will be saved. Some other options under the View menu item will be saved too. The next time that user launches iXp, the saved settings will determine the display format and the data shown.

4.1.5 File ► Save View as JIL

This enables users to generate a text file with JIL definition of all the jobs that are currently in view. This feature will generate the file as long as every job in view passes the user's JOB_DETAIL privilege. By default, the file will be shown in a web-browser.

4.1.6 File ► Set Time Zone

By default, the job run information displayed throughout the iXp Application is shown based on the time zone of the iXp client machine. For example, users launching the iXp client in Malaysia for CA Workload Automation AE jobs running in Chicago will see all the job run times in the corresponding Malaysian time zone. Using this menu option, users can set their time zone preference, and the job run data will be displayed based on the selected time zone.

iXp Administrators can use the Admin Tool to assign a timezone for each CA Workload Automation AE instance. In that case, iXp will always show the information in that timezone, irrespective of the value here.

File Menu:

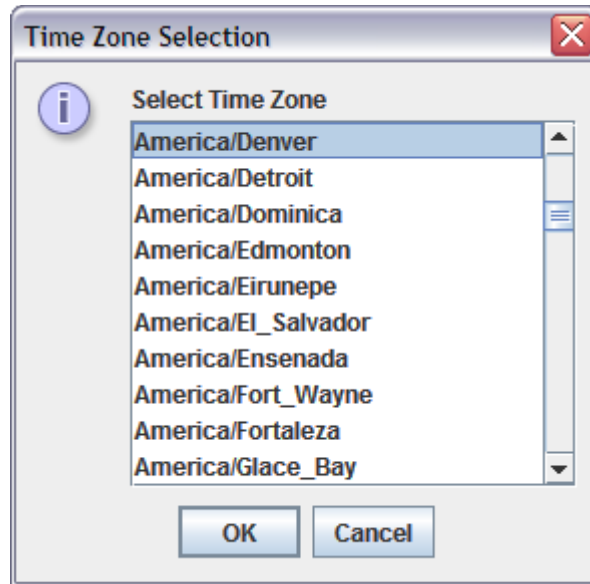

4.1.7 File ► Go Offline

Offline mode enables the *Interactive Forecasting* tool. Selecting **File ► Go Offline** will bring up the Confirmation dialog box.

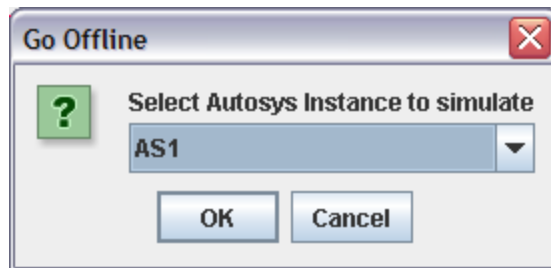

In Offline mode, all filtration and navigation actions derive results from the in-memory snapshot, not from the server. Offline mode provides a means to perform filter and view customization without the cost of roundtrip server invocations. After customizing the iXp setup, users may save their preferences and filters, and then go back Online with those preferences and filters.

In the Offline mode, Job Control actions such as job definition updates or sendevents are not possible.

To take the iXp session back online, select **File ► Go Online**.

4.1.8 File ► Change Password

Selecting **File ► Change Password** brings up the Password dialog box to change the iXp password for the current user.

File Menu:



A dialog box titled "Password" with a close button (X) in the top right corner. It contains three password input fields: "Enter Old Password" (filled with 8 dots), "Enter New Password" (filled with 8 dots), and "Reenter New Password" (empty). At the bottom, there are two buttons: "Save" and "Cancel".

4.1.9 File ► Sendevent

The **File ► Sendevent** menu option launches the sendevent dialog for creation of custom sendevents. This menu option is visible only if you are allowed to control jobs.

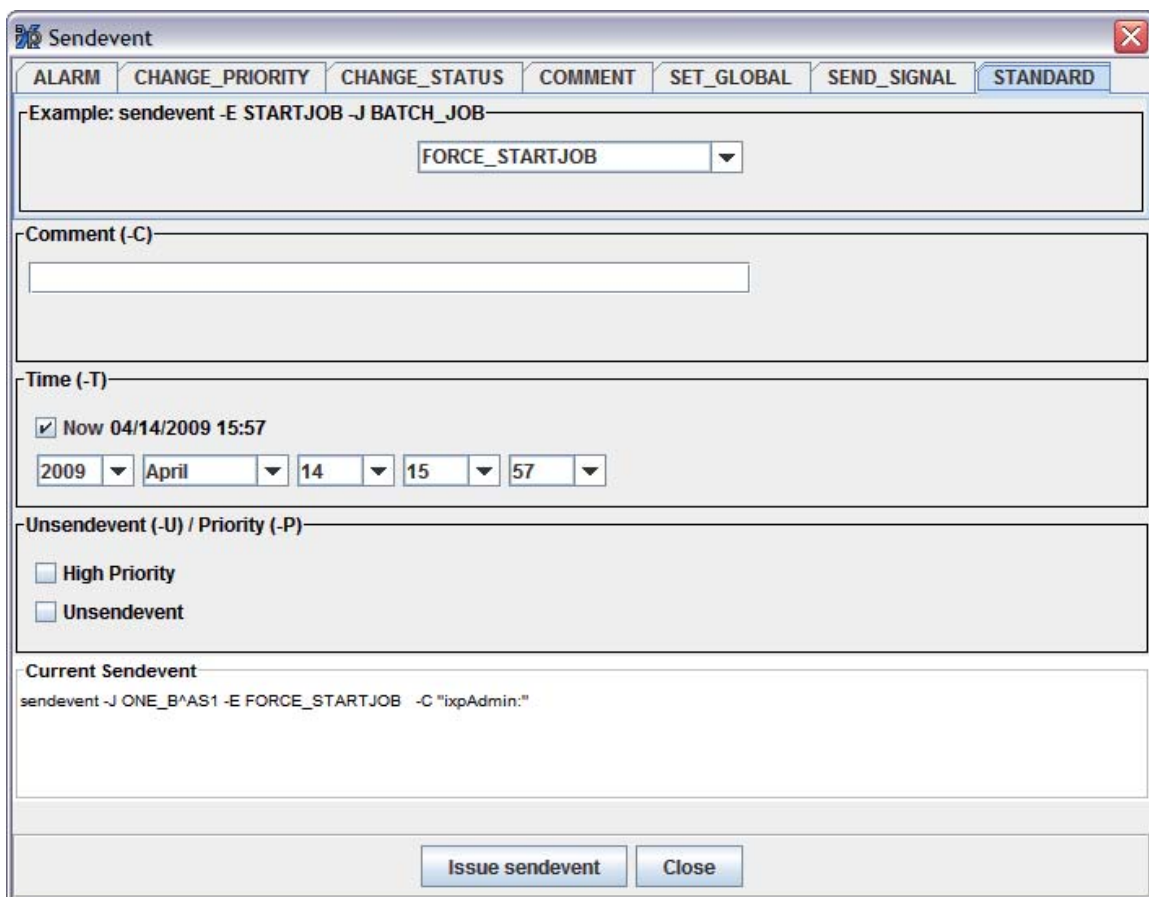

A dialog box titled "Sendevent" with a close button (X) in the top right corner. It features several tabs: "ALARM", "CHANGE_PRIORITY", "CHANGE_STATUS", "COMMENT", "SET_GLOBAL", "SEND_SIGNAL", and "STANDARD". The "STANDARD" tab is selected. Below the tabs, there is an example command: "Example: sendevent -E STARTJOB -J BATCH_JOB" and a dropdown menu showing "FORCE_STARTJOB". Below this is a "Comment (-C)" text area. The "Time (-T)" section has a checked box for "Now 04/14/2009 15:57" and a date/time picker showing "2009", "April", "14", "15", and "57". The "Unsendevent (-U) / Priority (-P)" section has two checkboxes: "High Priority" and "Unsendevent". The "Current Sendevent" section shows the command: "sendevent -J ONE_B^AS1 -E FORCE_STARTJOB -C \"ixpAdmin:\"". At the bottom, there are two buttons: "Issue sendevent" and "Close".

Select on the tabs in the Sendevent Dialog to create a custom sendevent. Select the **Issue Sendevent** button to issue the event to CA Workload Automation AE. Select the **Close** button to close the Sendevent Dialog.

File Menu:

Future Sendevent: The option **Time (-T)** provides a mechanism to issue events for a later date and time in advance, rather than doing it in person at that time. For example, a job may have been put ON_HOLD a few minutes ago and it is desired that the job be taken OFF_HOLD later that night. It would be easier to issue a **future** OFF_HOLD event on that job for that night, rather than to launch iXp to issue the command exactly at the desired time.

Uncheck the Now box to enter a time when the sendevent will occur.

4.1.9.1 Sendevent►Standard

The Sendevent►Standard tab creates default sendevents as does the Job Tools *Popup►Job Control*, with the option to alter the Sendevent time.

Standard Tab Item	Description
Example: Sendevent	Pick from the standard Sendevent listing: FORCE_STARTJOB, JOB_ON_HOLD, JOB_OFF_HOLD, JOB_ON_ICE, JOB_OFF_ICE, KILLJOB, STARTJOB. These are as in <i>Job Control►STARTJOB</i> .
Comment (-C)	Type a comment to be associated with the Sendevent.
Time (-T)	Select a time for the Sendevent, or select Now (the default time).
Current Sendevent	Lists the Sendevent(s) that have been selected. Select Issue Sendevent to issue to CA Workload Automation AE, or select Close to close the window without issuing any events.

4.1.9.2 Sendevent►Multi-Select

Jobs may be *multi-selected* in the Tree View or the Console View, for customization in the Sendevent Window. If more than ten jobs are selected, they are denoted in the Current Sendevent window as **J*** rather than a complete listing.

The illustration below shows a JOB_ON_HOLD event being sent to 3 jobs.

File Menu:

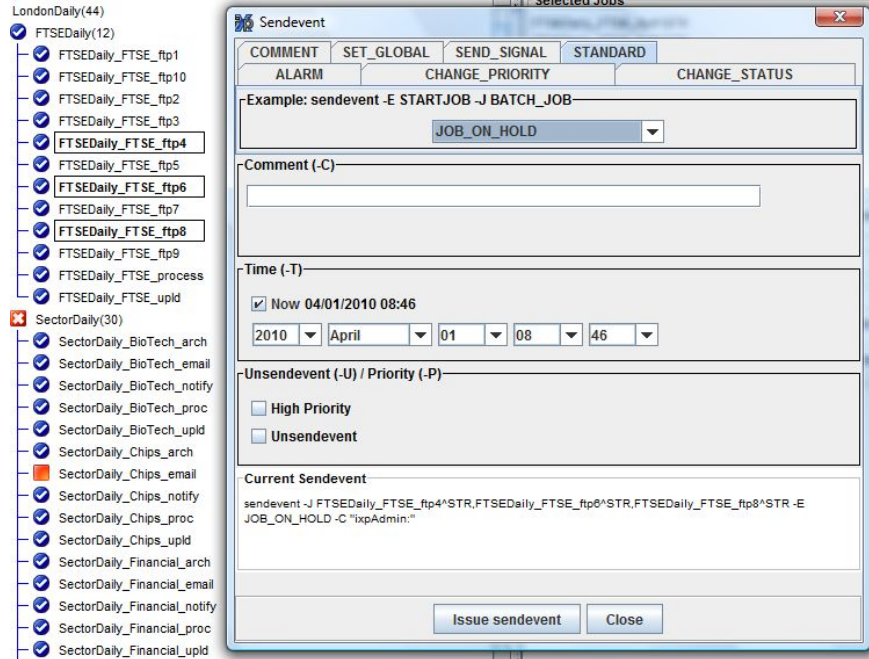

4.1.9.3 Sendevent ► CHANGE_STATUS

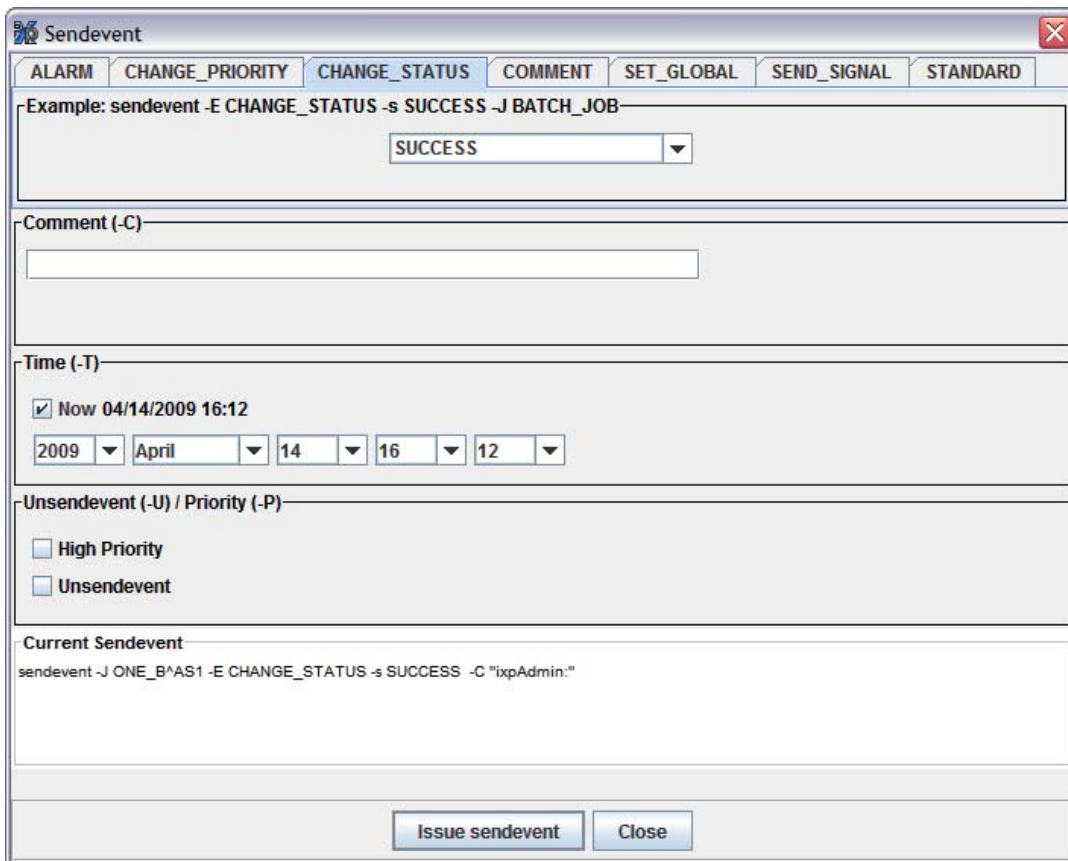

File Menu:

CHANGE_STATUS Tab Item	Description
Example: sendevent	Pick from the CHANGE_STATUS types: FAILURE, INACTIVE, RUNNING, SUCCESS, TERMINATED, as are in the Job Control Popup .

4.1.9.4 Sendevent ► ALARM

ALARM Tab Item	Description
Example: sendevent	Pick from the ALARM type listing: AUTO_PING, CHASE, DATABASE_COMM, DB_PROBLEM, DB_ROLLOVER, DUPLICATE_EVENT, EP_HIGH_AVAIL, EP_ROLLOVER, EP_SHUTDOWN, EVENT_HDLR_ERROR, EVENT_QUE_ERROR, FORKFAIL, INSTANCE_UNAVAILABLE, JOBFailure, JOBNOT_ONICEHOLD, MAXRUNALARM, MAX_RETRYS, MINRUNALARM,

File Menu:

	MISSING_HEARTBEAT, RESOURCE, STARTJOBFAIL, VERSION_MISMATCH.
--	---

4.1.9.5 Sendevent ► COMMENT

The screenshot shows the 'Sendevent' dialog box with the 'COMMENT' tab selected. The dialog has a title bar with a close button. Below the title bar are several tabs: ALARM, CHANGE_PRIORITY, CHANGE_STATUS, COMMENT (selected), SET_GLOBAL, SEND_SIGNAL, and STANDARD. The main area is divided into sections: 'Comment (-C)' with a text input field containing 'This is IMPORTANT!'; 'Time (-T)' with a checked checkbox for 'Now 04/14/2009 16:14' and a date/time picker showing '2009', 'April', '14', '16', and '14'; 'Unsendevent (-U) / Priority (-P)' with two unchecked checkboxes: 'High Priority' and 'Unsendevent'; and 'Current Sendevent' with a text area containing the command: 'sendevent -J ONE_B^AS1 -E COMMENT -C "ixpAdmin:This is IMPORTANT!"'. At the bottom are two buttons: 'Issue sendevent' and 'Close'.

COMMENT Tab Item	Description
Comment (-C)	Type a comment -- for stand alone COMMENT if no job is selected, or to go with selected job(s).

File Menu:

4.1.9.6 Sendevent ► SET_GLOBAL

The screenshot shows the 'Sendevent' dialog box with the 'SET_GLOBAL' tab selected. The dialog has a title bar with a close button. Below the title bar are several tabs: ALARM, CHANGE_PRIORITY, CHANGE_STATUS, COMMENT, SET_GLOBAL (selected), SEND_SIGNAL, and STANDARD. The main area is divided into several sections: 'Global Variables' with a dropdown menu showing 'RUNPAYROLL'; 'Values' with a dropdown menu showing 'YES'; 'Comment (-C)' with a text box containing 'This will release all the PAYROLL jobs.'; 'Time (-T)' with a checked checkbox for 'Now 04/14/2009 16:14' and a date/time picker showing '2009', 'April', '14', '16', and '14'; 'Unsendevent (-U) / Priority (-P)' with two unchecked checkboxes: 'High Priority' and 'Unsendevent'; and 'Current Sendevent' with a text box containing the command: 'sendevent -E SET_GLOBAL -G "RUNPAYROLL=YES" -C "ixpAdmin:This will release all the PAYROLL jobs."'. At the bottom are two buttons: 'Issue sendevent' and 'Close'.

Set_Global Tab Item	Description
Global Variables	Select <i>Global Variable(s)</i> that must be created or updated. All existing variables are provided in the pull-down list.
Values	Select Value(s) for the Global Variable(s). All the values for the existing global variables are provided in the pull-down list.

File Menu:

4.1.9.7 Sendevent ► CHANGE_PRIORITY

The screenshot shows the 'Sendevent' application window with the 'CHANGE_PRIORITY' tab selected. The window title is 'Sendevent'. The tab bar contains: ALARM, CHANGE_PRIORITY (selected), CHANGE_STATUS, COMMENT, SET_GLOBAL, SEND_SIGNAL, and STANDARD. The main content area is divided into several sections:

- Example:** sendevent -E CHANGE_PRIORITY -q 10. Below this is a dropdown menu with the value '1' selected.
- Comment (-C):** A text input field containing 'This will expedite the job.'
- Time (-T):** A checked checkbox for 'Now 04/14/2009 16:16'. Below it are five dropdown menus for date and time: 2009, April, 14, 16, 16.
- Unsendevent (-U) / Priority (-P):** Two checkboxes: 'High Priority' (unchecked) and 'Unsendevent' (unchecked).
- Current Sendevent:** A text area containing the command: `sendevent -J ONE_B^AS1 -E CHANGE_PRIORITY -q 1 -C "ixpAdmin:This will expedite the job."`

At the bottom of the window are two buttons: 'Issue sendevent' and 'Close'.

CHANGE_PRIORITY Tab Item	Description
Priority	Select the priority value to be assigned to the chosen job. You can pick a value from the drop-down menu or type it in.

File Menu:

4.1.9.8 Sendevent ► SEND_SIGNAL

The screenshot shows the 'Sendevent' dialog box with the 'SEND_SIGNAL' tab selected. The dialog has a title bar with a close button. Below the title bar are several tabs: ALARM, CHANGE_PRIORITY, CHANGE_STATUS, COMMENT, SET_GLOBAL, SEND_SIGNAL (selected), and STANDARD. The main content area is divided into several sections:

- Example:** sendevent -E SEND_SIGNAL -k SIGTERM. Below this is a drop-down menu with the value '2' selected.
- Comment (-C):** A text box containing the text 'This will gracefully shut down the job.'
- Time (-T):** A checked box for 'Now 04/14/2009 16:16' and a date/time picker showing 2009, April, 14, 16, 16.
- Unsendevent (-U) / Priority (-P):** Two unchecked checkboxes: 'High Priority' and 'Unsendevent'.
- Current Sendevent:** A text box showing the command: 'sendevent -J ONE_B^AS1 -E SEND_SIGNAL * 2 -C "ixpAdmin:This will gracefully shut down the job."'.

At the bottom of the dialog are two buttons: 'Issue sendevent' and 'Close'.

SEND_SIGNAL Tab Item	Description
Kill Signal	Select the kill signal to be sent to the chosen job. You can pick a value from the drop-down menu or type it in.

4.1.10 File ► Retrieve Run Data

If the Retrieve Run Data box is not checked, the historical and forecasted job runs would not be retrieved by the client. If it is checked, then the run data will be retrieved by the client and appear in the [Time View Chart](#). Turning off Retrieve Run Data can improve the application speed especially for dial-up use.

4.1.11 File▶ Retrieve Alarm Data

If this box is checked, the user will receive the alarm data for all the jobs allowed. By un-checking this box, users can speed-up the client, especially over slower networks. This menu item is available only if the user has been assigned with the privilege to see CA Workload Automation AE Alarms.

4.2 Edit Menu

4.2.1 Edit▶ Undo:

Select **Edit▶ Undo:** to undo the most recent iXp *view function* performed, such as Expand or Include. Then, sequentially, the previous functions become available for Undo.

In the example, the SectorDaily job was hidden by selecting it and using the right-click menu Hide option.

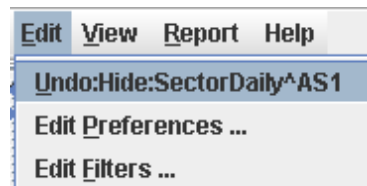

Selecting **Undo** then returns the job to the view.

4.2.2 Edit▶ Edit Filters

Edit▶ Edit Filters brings up the *Filter Editor*. See the *JOB FILTERS* section of this document for a description of the Filter Editor, Filter configurations and Filter use.

4.2.3 Edit▶ Edit Preferences...

Brings up the **Preference Editor** dialog, shown below. The Preference Editor allows you to set job status colors and to adjust other iXp job view parameters.

Edit Menu

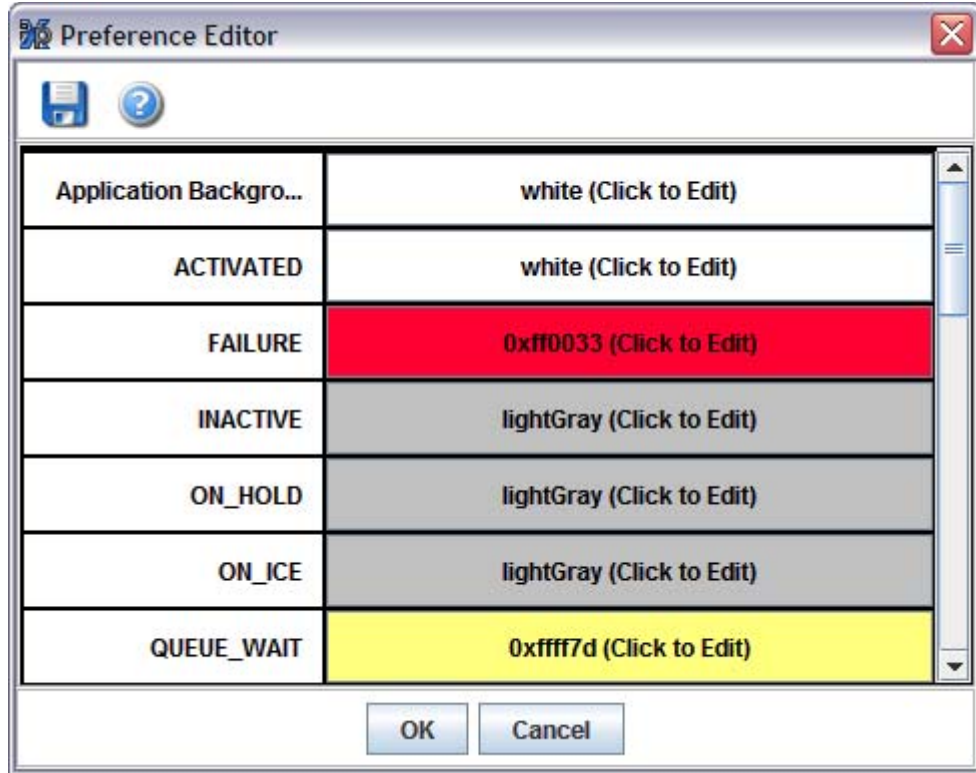

Preference Name	Description
ACTIVATED Color	Color for the job icon in all Views when the job is in ACTIVATED status.
Application Background	Background color for iXp GUI. Allows users to visually differentiate between multiple iXp GUI windows.
FAILURE Color	Color for the job icon in all Views when the job is in FAILURE status.
INACTIVE Color	Color for the job icon in all Views when the job is in INACTIVE status.
ON_HOLD Color	Color for the job icon in all Views when the job is in ON_HOLD status.
ON_ICE Color	Color for the job icon in all Views when the job is in ON_ICE status.
PEND_MACH Color	Color for the job icon in all Views when the job is in PEND_MACH status.
QUEUE_WAIT Color	Color for the job icon in all Views when the job is

	in QUEUE_WAIT status.
RESWAIT Color	Color for the job icon in all Views when the job is in RESWAIT status.
RESTART Color	Color for the job icon in all Views when the job is in RESTART status.
RUNNING Color	Color for the job icon in all Views when the job is in RUNNING status.
STARTING Color	Color for the job icon in all Views when the job is in STARTING status.
SUCCESS Color	Color for the job icon in all Views when the job is in SUCCESS status.
TERMINATED Color	Color for the job icon in all Views when the job is in TERMINATED status.
WAIT_REPLY Color	Color for the job icon in all Views when the job is in WAIT_REPLY status.

Aside from colors, the following Preferences can be specified.

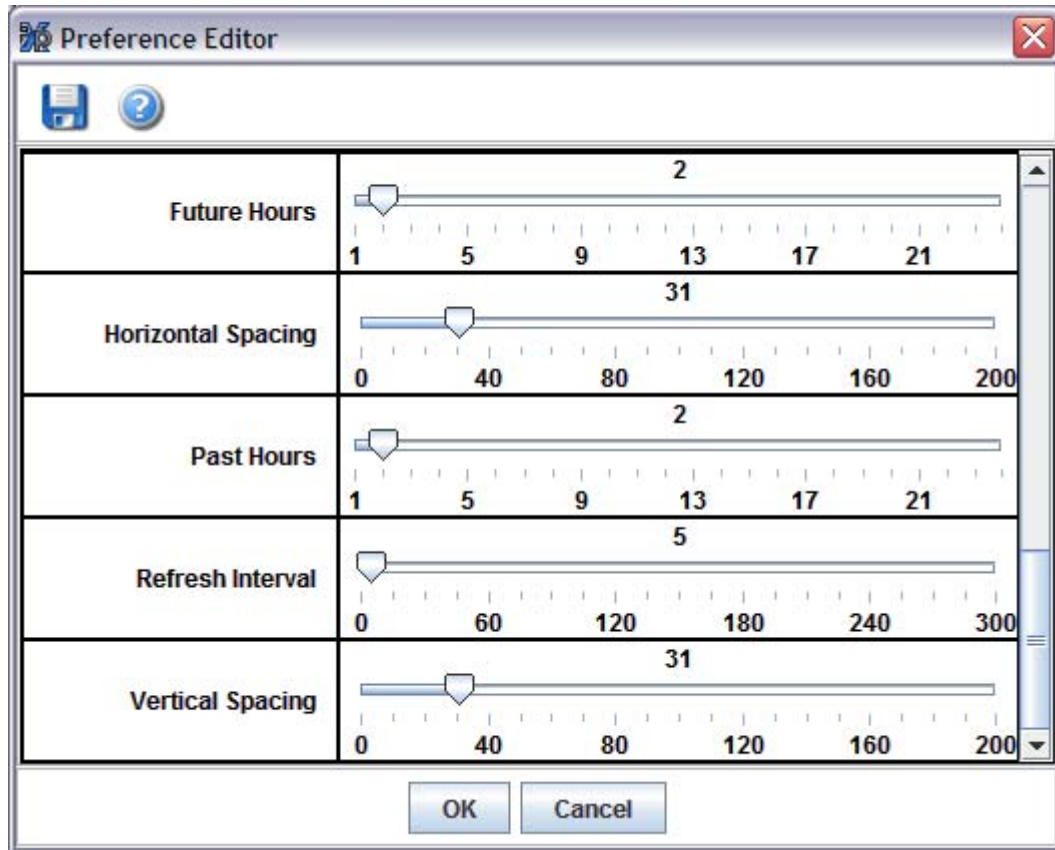

Preference Name	Description
Filter	The Filter specifies to the iXp Daemon about the kind of data the user wishes to view. See the Job Filters section of this document.
Job Name Font	Sets the font type for the job names in the Job Flow View. Click on Job Name Font to bring up the font chooser window.
Table Font	Sets the font type for iXp table views.
Tree Font	Sets the font type for iXp tree views.
Future Hours	Sets the number of hours of forecast data visible in the Time View chart window.
Horizontal Spacing	Sets the horizontal spacing between jobs in the Job Flow View window.
Past Hours	Sets the number of hours of historical data visible in the Time View chart window.

Refresh Interval	Sets the number of seconds between iXp client refreshes.
Vertical Spacing	Sets the vertical spacing between jobs in the Job Flow View window.



After setting new preferences, click on the Save icon to save the new preferences.

Once preferences are saved, you can change them by saving new ones.

4.2.3.1 Color Editor

Left-click the mouse on the value for a status color, such as “FAILURE Color” to bring up the **Color Editor**:

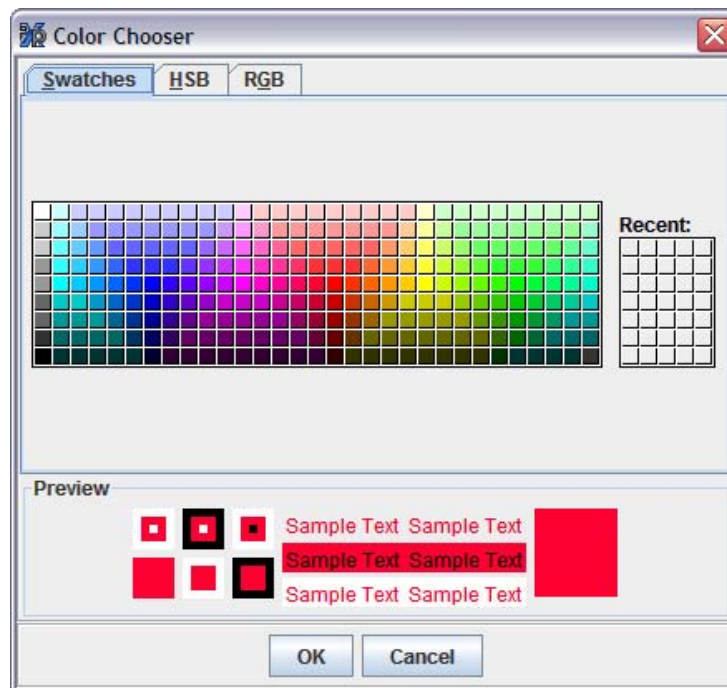

Use the Swatches, HSB or RGB tabs to choose the color for the chosen status. In the Swatches tab, select on a color swatch. In the HSB tab, drag the marker around in the color selection square. In the RGB tab use the scroll bars to select the color.

Select **OK** in the Color Editor to show the color in the Preferences Editor window. Select OK again in the Preferences Editor to apply the new status color to the iXp views.

4.2.3.2 Filter Editor

Click on the Filter Value in the Preference Editor to bring up the **Filter Editor**. Use the filter editor to adjust the configurations of the job attributes for any filter. The iXp Daemon sends only that data to the iXp client which passes the Current Filter. See the [JOB FILTERS](#) section of this document for a description of the Filter Editor, Filter configurations and Filter use.

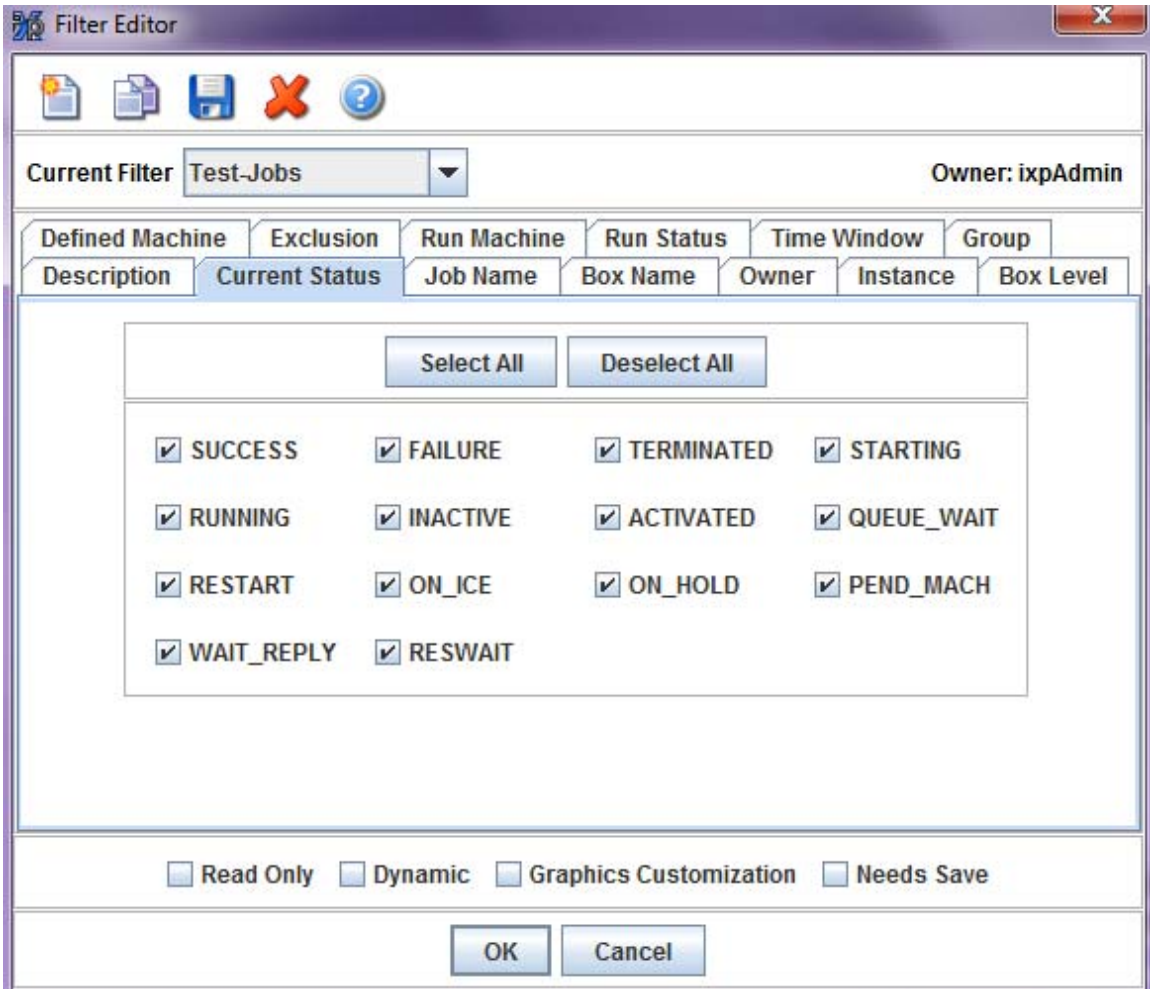

4.3 View Menu

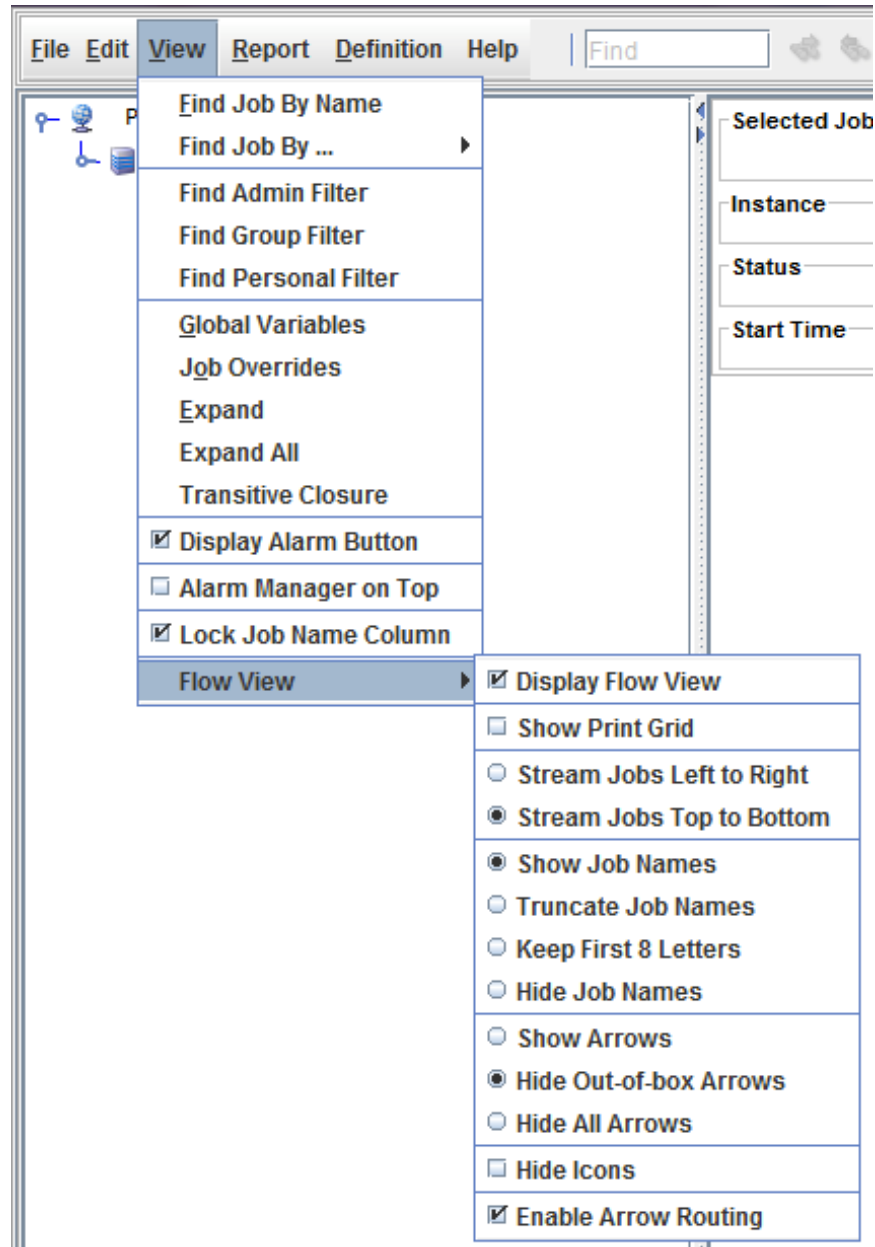

4.3.1 View ► Find Job By Name

View ► Find Job By Name brings up the Find By Name window. Enter a wild-card string and hit **<Enter>** to see the list of jobs whose name matches the string.

Select one or more jobs and choose **OK** to highlight the job(s) in the job view windows. If the selected job(s) are not in the job views, the job views will expand to include the selected job. Also, double-clicking a job selects that job in the Views. Select the **Refresh** button in the Find By Name window to refresh the list

of job names. Select **Cancel** to exit the Find By Name window without selecting any jobs.

Narrow the names on the Find By Name list by typing a wildcard name string in the “Job Name” field and then hitting the **Enter** key on the keyboard. iXp assumes you are searching for job names rather than instances. A ^ denotes the instance name following each job name. The job name matching is **not** case-sensitive.

Typing one or more characters after a * finds the job names ending in that character, not the instance name (E*2 finds job names ending in 2, regardless of whether on instance JU2 or JU3). That is, *xyz expands to *xyz^*.

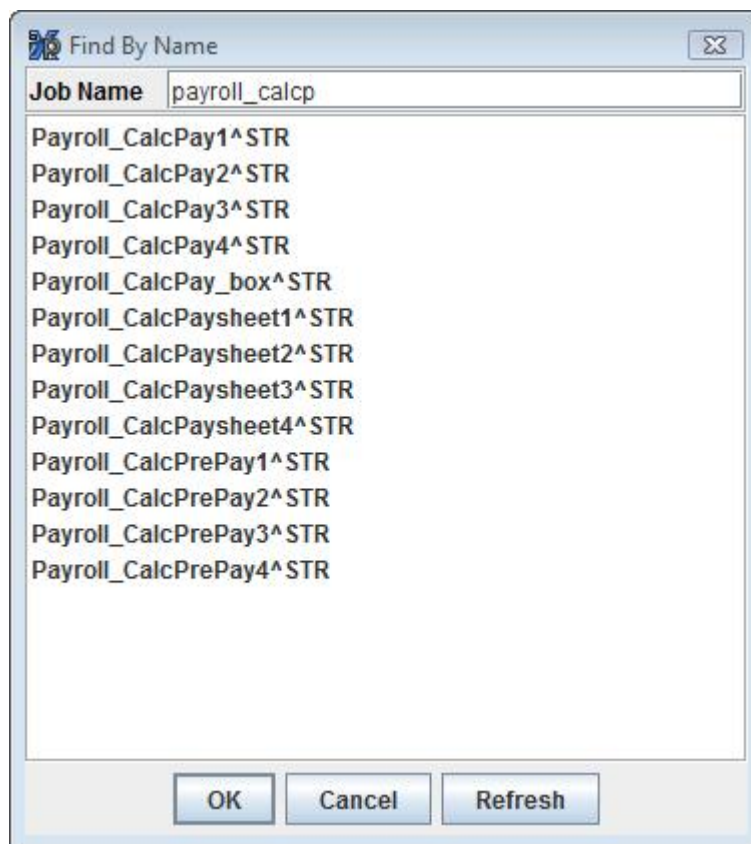

4.3.2 View ► Find Job By ...

View ► Find Job By... provides options for locating a particular job.

View Menu

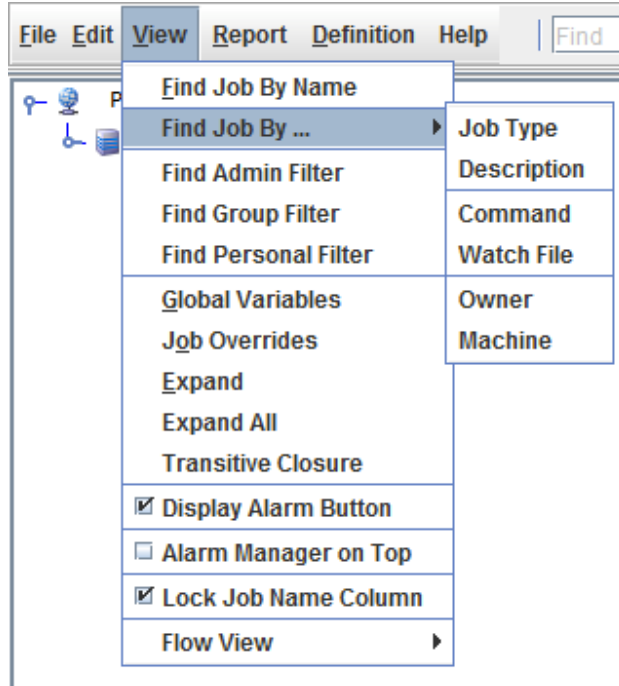

Options provided are Job Type (command, box, file watcher), Description, Command, Watch File (name), Owner, or Machine. Instance is an option for each search as is Job Name. Find by Job Type example is shown below:

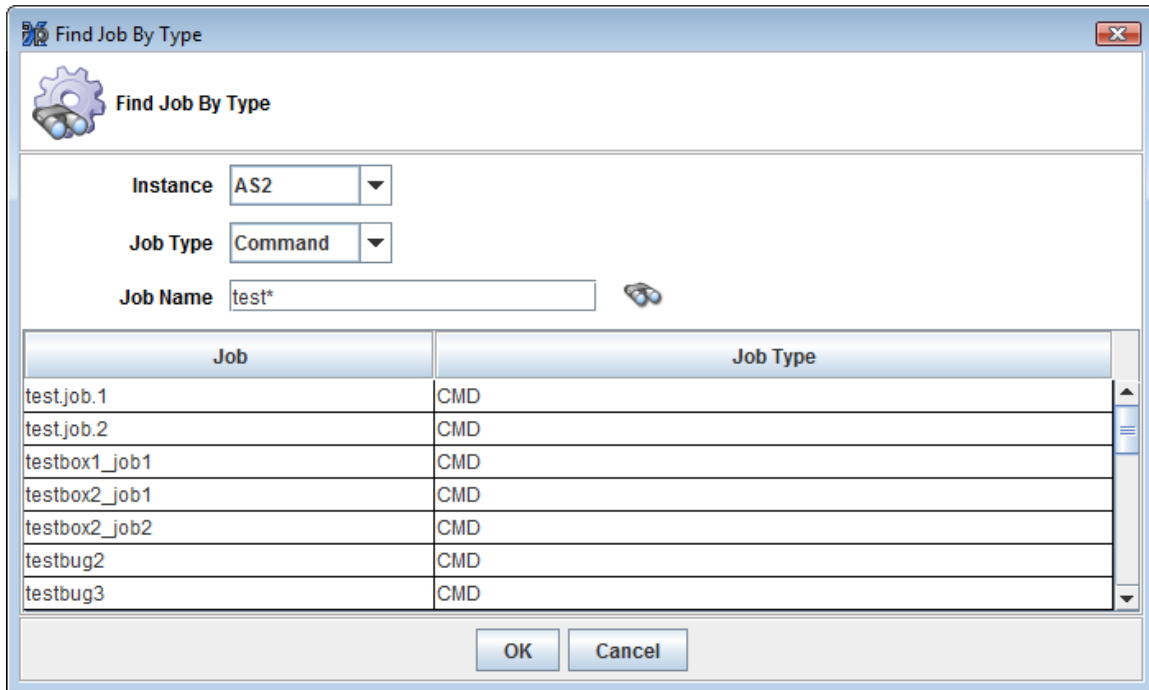

After entering the search conditions (in this case Job Type is “command” and Job Name is “test*”) click the search icon  to find matching jobs, then select one

and click OK. The specified job will become the highlighted/selected job in all iXp views.

4.3.3 View ► Find Admin Filter

View ► Shared Filter shows a dialog where users can find all or any of the Shared Filters that have been created and shared by the Administrators. These filters can be modified only by the Administrators. Users can search for the desired filter by providing a name with wild cards.

You will see only those filters that have been either shared globally, or have been assigned to one or more of your groups.

Some filters may not provide any data for some users, as their security settings may not allow them to view the jobs specified in the filters. To import newly created shared filters, iXp clients must be re-launched.

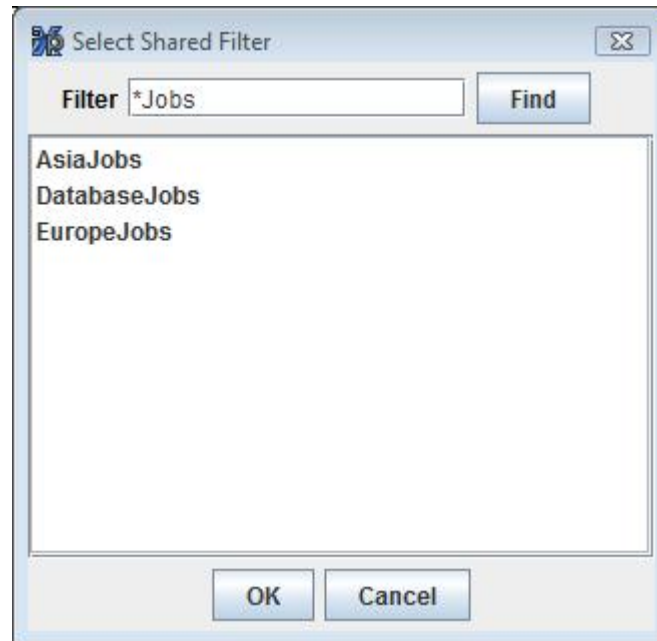

4.3.4 View ► Find Personal Filter

View ► Personal Filter shows a dialog with all the filters created by the user, and the standard filters provided by iXp. If the user is an Admin User, then this dialog will show those filters that have been created by the user and not shared with other users.

This dialog is similar to the Shared Filters dialog.

4.3.5 View ► Find Group Filter

View ► Find Group Filter shows a dialog with all the filters for the group, and the standard filters provided by iXp.

4.3.6 View ► Global Variables

View ► Global Variables brings up the Global Variables information window.

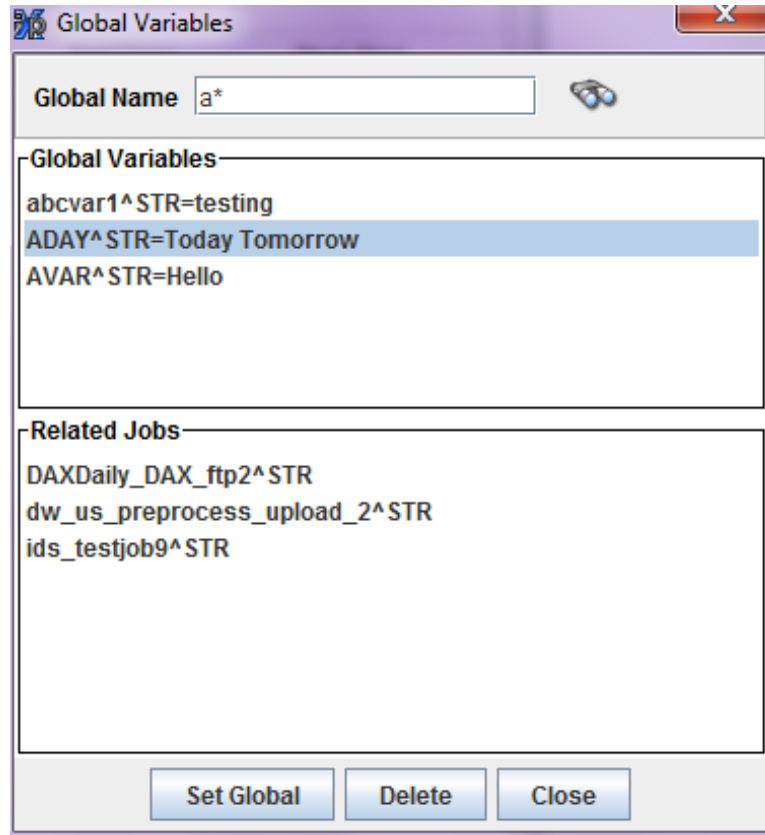

By default, all Global Variables that a user is allowed to view are displayed, along with their current values. To search for a specific variable, type a string in the box (* wildcard is supported) and click the search icon. The search is not case-sensitive.

Select a Global Variable in the top section of the window to view Related Jobs in the lower section of the window.

Related Jobs are jobs that depend on the Global Variable, or jobs that set the Global Variable (using a sendevent in the job definition command line). Global Variables are set using the CA Workload Automation AE sendevent SET_GLOBAL command.

View Menu

Select a job in the lower section to select that job in the iXp job view windows.

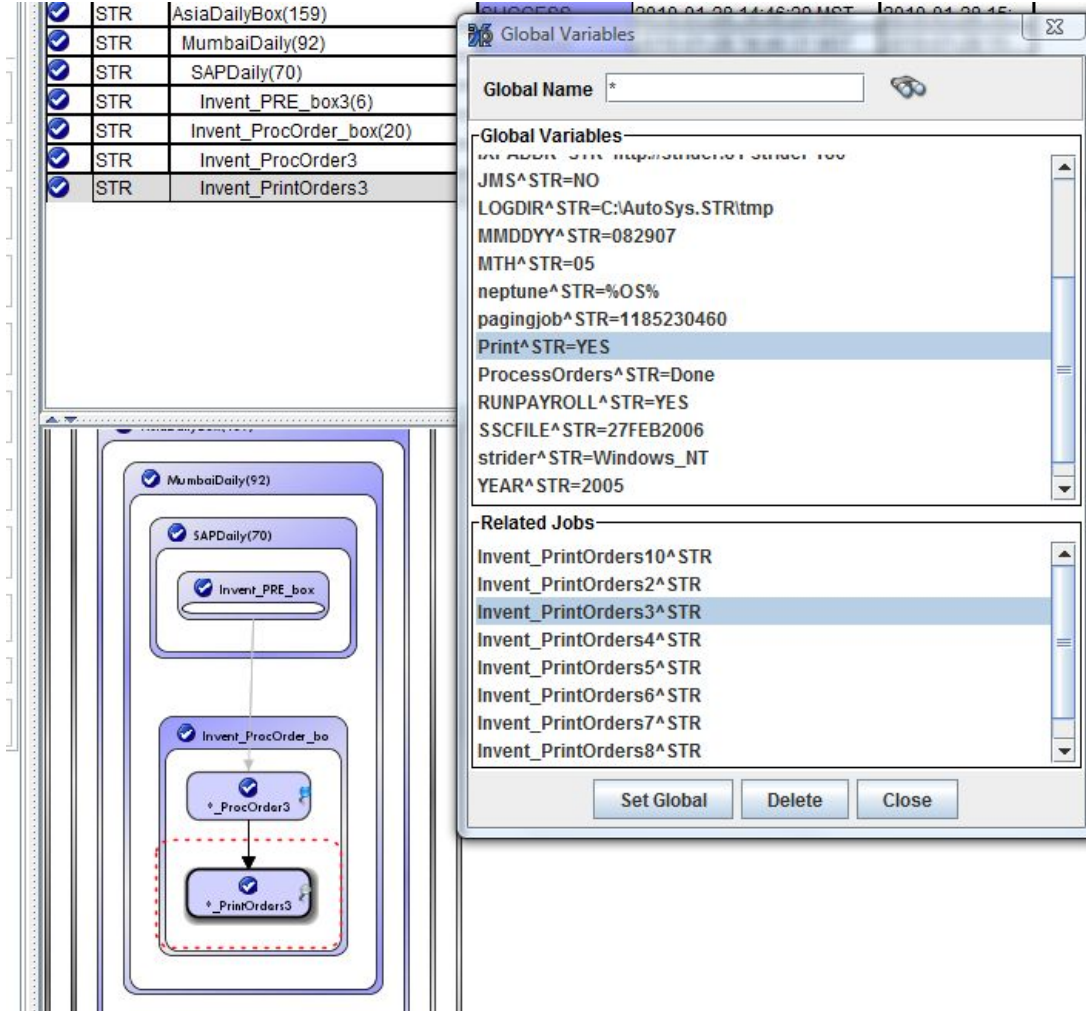

4.3.7 View ► Job Overrides

Select **View ► Job Overrides** to bring up the *Override Job* view window, populated with job names of jobs that have current Overrides. Select a job name and then select **View Override** to see the Overrides for that job.

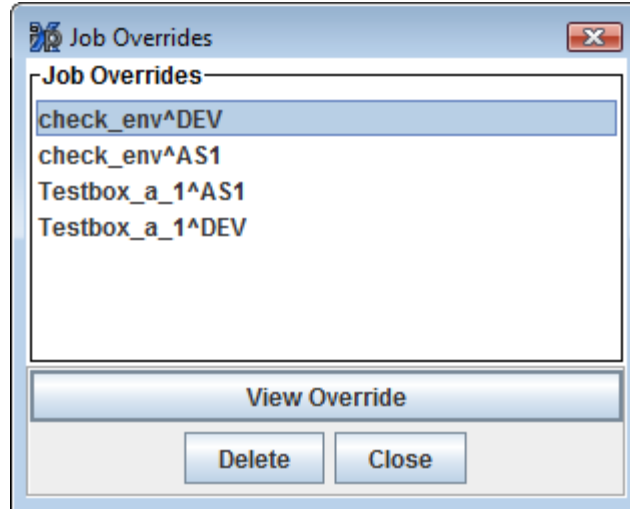

To delete an override, click on the Delete button. You will be required to confirm that you want to delete the override.

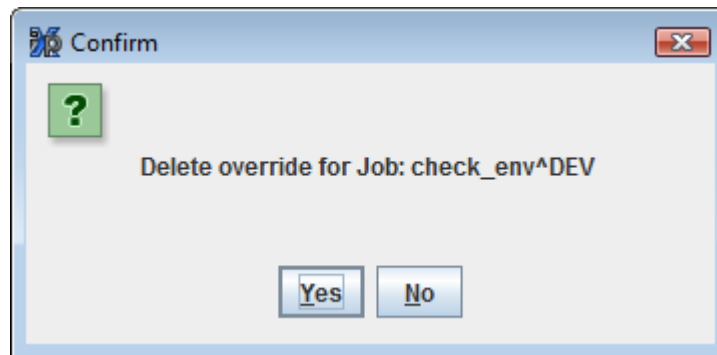

The Close button closes the dialog without affecting any of the jobs and overrides listed.

4.3.8 View ► Expand

Select **View ► Expand** to expand all the box jobs in the current view by one more level. This is an easy way to drill down in all the displayed box jobs one level at a time. See also [Expand](#), [Collapse](#).

4.3.9 View ► Expand All

Select **View ► Expand All** to expand all the box jobs in the view to show all the jobs contained in the box. This is an easy way to drill all the way down in all the displayed box jobs. See also [Expand](#), [Collapse](#).

4.3.10 View► Transitive Closure

Select **View► Transitive Closure** to show the transitive closure of all the jobs in the view. This could result in jobs being imported in to the view to display the complete closed set of jobs for all the jobs in the view.

Please refer to [Section 7.3.1](#) for more information on Transitive Closure.

4.3.11 View► Display Alarm Button

Un-check the **View► Display Alarm Button** to hide the Alarm Button from the bottom part of the GUI.

4.3.12 View► Alarm Manager on Top

If you are viewing the Alarm Manager (which can be launched by clicking on the Alarm button) and you click on the main GUI screen, then the Alarm Manager will be sent to the background. You will have to click on the icon for “iXp” on the taskbar to bring it to the foreground. If you enable this menu option, then the Alarm Manager will never be sent to background, even if you are working in the main GUI.

4.3.13 View► Lock Job Name Column

The **View► Lock Job Name Column** check box controls the sizing of the first three columns in the Console View. When this option is unchecked, users can resize the first three columns. To lock in the selected size, just recheck this option.

4.4 View ► Flow View

4.4.1 View ► Flow View ► Display Flow View

Check the box hide the Job Flow View by checking the box next to **View ► Flow View ► Display Flow View** option. This option is useful when you are looking at thousands of jobs, as showing them in the Flow View will increase the consumption of system resources on your client machine.

4.4.2 View ► Flow View ► Show Print Grid

Check the box in **View ► Flow View ► Show Print Grid** to show the Print Grid in the Job Flow View. The Print Grid shows the resulting layout of print pages for the *File ► Print* functionality.

The advantage of Show Print Grid is that after seeing the print layout, you can customize the print by zooming in or out. The print grid can be turned off by selecting the radio button again.

4.4.3 View ► Flow View ► Stream Jobs

The **View ► Flow View ► Stream Jobs** options control the orientation of the *Job Flow View*. If the default setting, **Stream Jobs Top to Bottom**, is selected, jobs in the Flow View flow primarily top to bottom.

If **Stream Jobs Left to Right** is selected, jobs in the Flow View flow primarily in that direction.

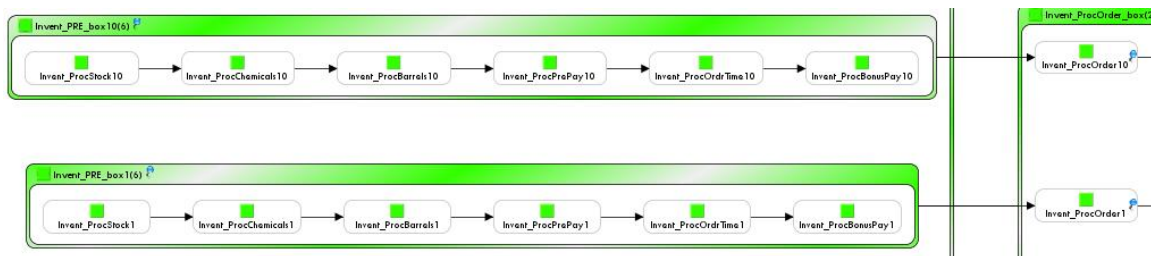

4.4.4 View ► Flow View ► Show Job Names

The **View ► Flow View ► Show Job Names** option shows the entire job name in the Flow View. This could increase the size of the job representation in the view.

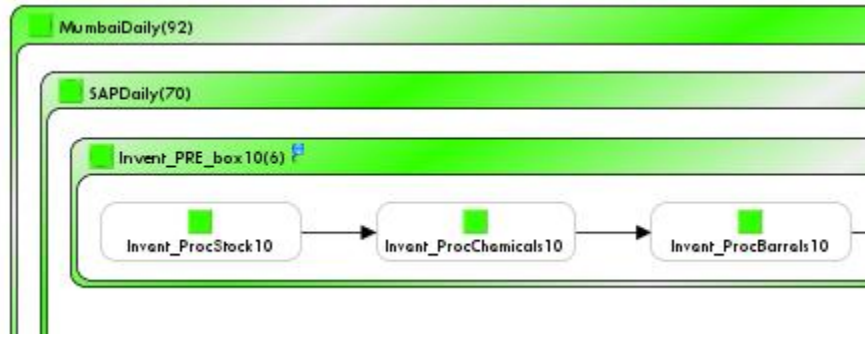

4.4.5 View ► Flow View ► Truncate Job Names

The **View ► Flow View ► Truncate Job Names** option controls the abbreviation of job names as they appear in iXp. If “Truncate Job Names” is checked, job names are abbreviated in the Flow View based on shared prefixes of sibling jobs. The following image shows the same jobs as in the previous option, but with this setting turned on.

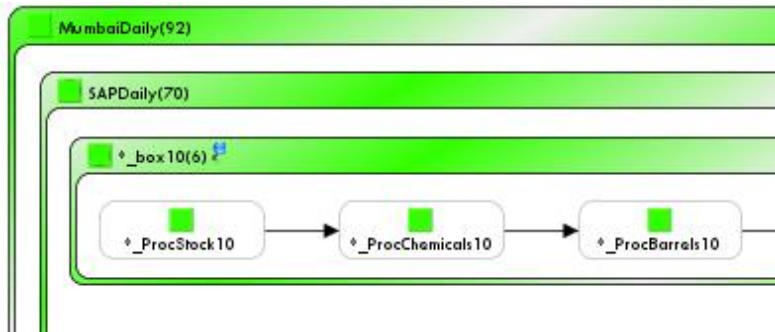

Notice how the letters “Invent” are replaced with an “*”.

4.4.6 View ► Flow View ► Keep First 8 Letters

The **View ► Flow View ► Keep First 8 Letters** is another option to control the abbreviation of job names as they appear in iXp. After truncating the job name (see the Truncate Job Names option, above) only the next 8 characters are shown. The rest of the job name is also truncated.

4.4.7 View ► Flow View ► Hide Job Names

The **View ► Flow View ► Hide Job Names** does away with job names in Flow View leaving just the icons. This is useful for getting a “big picture” view of a job stream.

4.4.8 View ► Flow View ► Show Arrows

The **View ► Flow View ► Show Arrows** check box controls the drawing of arrows in the Job Flow View. If it is enabled, the view displays all job relationship arrows. This is the default option.

4.4.9 View ► Flow View ► Hide Out of Box Arrows

The **View ► Flow View ► Hide Out of Box Arrows** option controls the drawing of arrows for out-of-box dependencies. If this option is selected, then the Flow View will not display arrows for such dependencies.

4.4.10 View ► Flow View ► Hide All Arrows

The **View ► Flow View ► Hide All Arrows** option controls the drawing of all arrows in the Flow View. If this option is selected, then the Flow View will not display any arrows between jobs. If you select a job, then the arrows to the immediate predecessors and successors of that job will be shown.

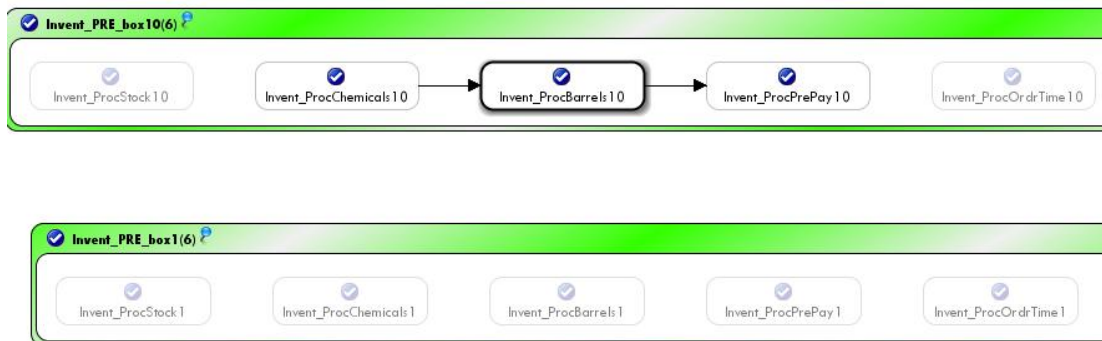

4.4.11 View ► Flow View ► Hide Icons

The **View ► Flow View ► Hide Icons** option shows the job representations in the Flow View without any status icons or pins. This reduces the size of the job representations, and enables users to fit more jobs in the Flow View window.

4.4.12 View ► Flow View ► Enable Arrow Routing

The **View ► Flow View ► Enable Arrow Routing** option applies an “arrow-routing” algorithm to the Flow View. When this option is selected, the arrows will go around jobs, rather than over or behind them. This option can be selected only when jobs are being streamed from Top to Bottom.

View ► Flow View

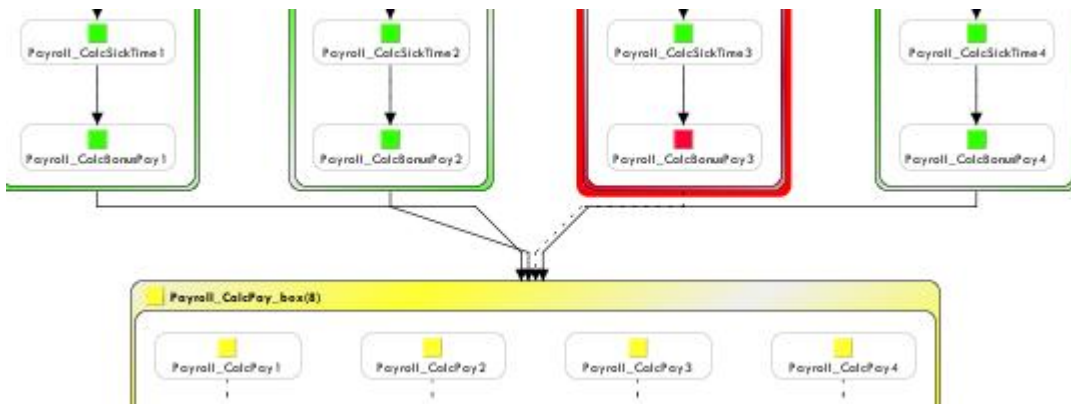

4.5 Report Menu

Reports list selected job runs of special interest. iXp users can filter job runs based on relative or absolute times, job names, box names, machine names, and job run statuses. The resulting data can be sorted by job name, job start time, or job hierarchy. All the reports are generated in HTML format and are returned to the user in a web browser.

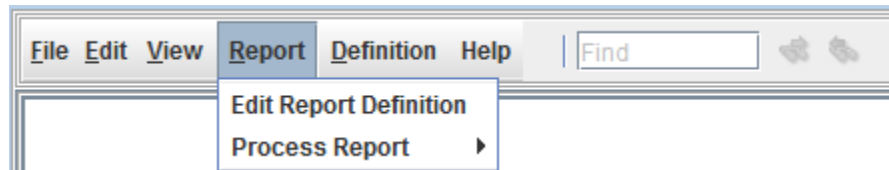

4.5.1 Report Editor

Select **Report►Edit Report Definition** to bring up the Reports Editor:

4.5.1.1 Report Management

Use the Reports Editor File menu to create and delete report types. Select **File►Create New Report** then enter a name in the Input box to begin a report creation.

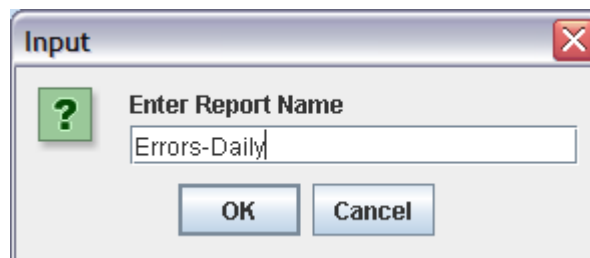

Then use the different tabs in the Report Editor to define the Report.

Report Menu

<u>Reports Tab</u>	<u>Usage</u>
Instance	Select CA Workload Automation AE instance of jobs to be reported.
Time	Identify the times of jobs to be reported. Select Absolute to specify an absolute start time to end time window. Select Relative to choose a time window in the past from the present time.
Status	Select the run status(es) of jobs to be reported: SUCCESS, FAILURE, TERMINATED, RUNNING.
Row Count	Select number of rows to be reported, to limit the report length, or select "No Limit".
Machines	Insert and delete expressions for machine names of job runs to be reported.
Jobs	Insert and delete expressions for job names to be reported.

Report Menu

Boxes	Insert and delete expressions for box names of job runs to be reported. If a box name is specified here, the report will be generated on the box job and all of the jobs within that box job. This is an easier and intuitive way to generate reports for sets of box jobs.
Order	Select order of jobs in the report: autorep (the default order), alphabetical, by start time, or “Last Run Only” for only the most recent.
Group	Select Groups to be included in the Report.

Select **File► Save** to save the report creation.

Select **File► Delete** to delete the report name shown in the Report window.

Select **File► Copy** to create a copy of the report name populated in the Report window.

Select **File► Process** to process the report name populated in the Report window. The result will appear in a new browser window.

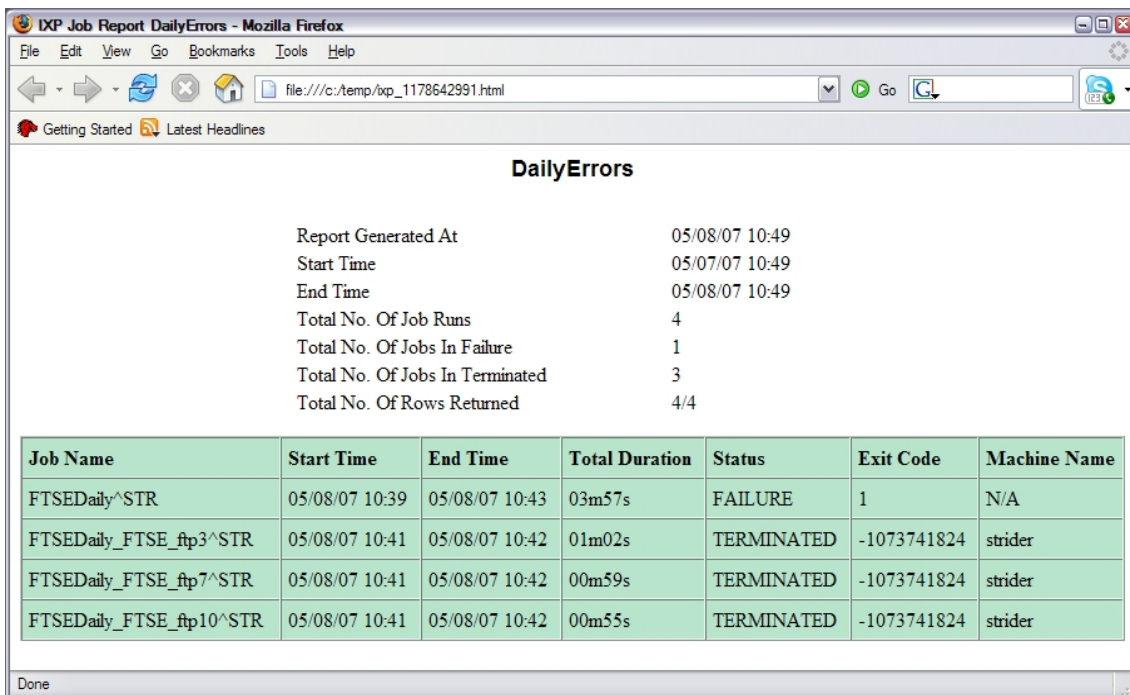

The screenshot shows a browser window titled "IXP Job Report DailyErrors - Mozilla Firefox". The address bar shows the file path: file:///c:/temp/ixp_1178642991.html. The report content includes a summary section and a table of job runs.

Job Name	Start Time	End Time	Total Duration	Status	Exit Code	Machine Name
FTSEDaily^STR	05/08/07 10:39	05/08/07 10:43	03m57s	FAILURE	1	N/A
FTSEDaily_FTSE_frp3^STR	05/08/07 10:41	05/08/07 10:42	01m02s	TERMINATED	-1073741824	strider
FTSEDaily_FTSE_frp7^STR	05/08/07 10:41	05/08/07 10:42	00m59s	TERMINATED	-1073741824	strider
FTSEDaily_FTSE_frp10^STR	05/08/07 10:41	05/08/07 10:42	00m55s	TERMINATED	-1073741824	strider

From the main menu, select **Report► Process Report** to choose a report for processing from the picklist.

Report Menu

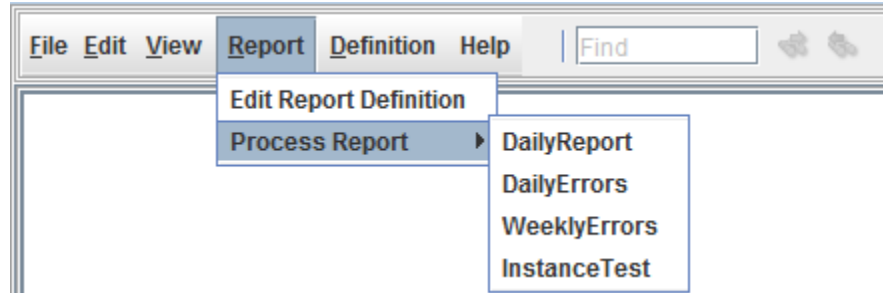

Three “out of the box” reports are delivered with iXp: **DailyErrors**, **DailyReport** and **WeeklyErrors**. These cannot be edited, and iXpAdmin-created reports cannot be edited by any user other than iXpAdmin.

The **DailyErrors** report shows all job runs that resulted in FAILURE and TERMINATED in the last 24 hours.

The **DailyReport** report shows all job runs that occurred over the last 24 hours.

The **WeeklyErrors** report shows all job runs that resulted in FAILURE and TERMINATED in the last 7 days.

This list will also show the following reports:

- Reports that have been created by you.
- Reports that have been globally shared by the Administrators.
- Reports that have been assigned to one or more of your groups.

4.6 Definition Menu

The **Definition Menu** selections enable users to create and edit CA Workload Automation AE calendars and jobs.

4.6.1 Edit Calendars

The Edit Calendars selection provides a GUI based editor for CA Workload Automation AE Calendars.

Select the CA Workload Automation AE Instance and Calendar name in the pull-down boxes:

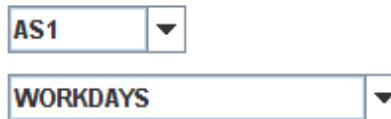

AS1

WORKDAYS

The default view is 3 months of the current year starting with the current month. You can change the view by selecting the number of months and the year on these pull-down boxes:



3 Month View

2008

In addition, the forward/reverse buttons can move through the calendar:



The forward and reverse buttons move by 3 months at a time, the fast forward/fast reverse move by 1 year at a time.











Clicking on a date will toggle the inclusion of that date in the calendar. When the date is included, it will be displayed in color (default green). If the date is not included, there is no background color. In the example below, November 10th and 20th 2009 are included in the displayed calendar.

Definition Menu

November 2009

S	M	T	W	T	F	S
1	2	3	4	5	6	7
8	9	10	11	12	13	14
15	16	17	18	19	20	21
22	23	24	25	26	27	28
29	30					

4.6.1.1 Menu options

<u>Menu Icon</u>	<u>Functionality</u>
	Create new calendar
	Copy current calendar to new name (requires save)
	Save current calendar
	Save On Alternate Instance—copy this calendar to a different CA Workload Automation AE instance
	Delete current calendar
	Clear all dates in current calendar
	Find a calendar by name
	Reload calendar from the CA Workload Automation AE database—all unsaved changes will be lost.
	Generate calendar dates by rule (see “Calendar Generator Dialog” below).
	Display Help.

4.6.1.2 Calendar Generator Dialog

Clicking on the calculator icon brings up the Calendar Generator Dialog. This tool assists in creating calendars with dates that follow a pattern. For example, a calendar that includes the 10th, 20th, and 30th of every month can be created with the settings shown below:

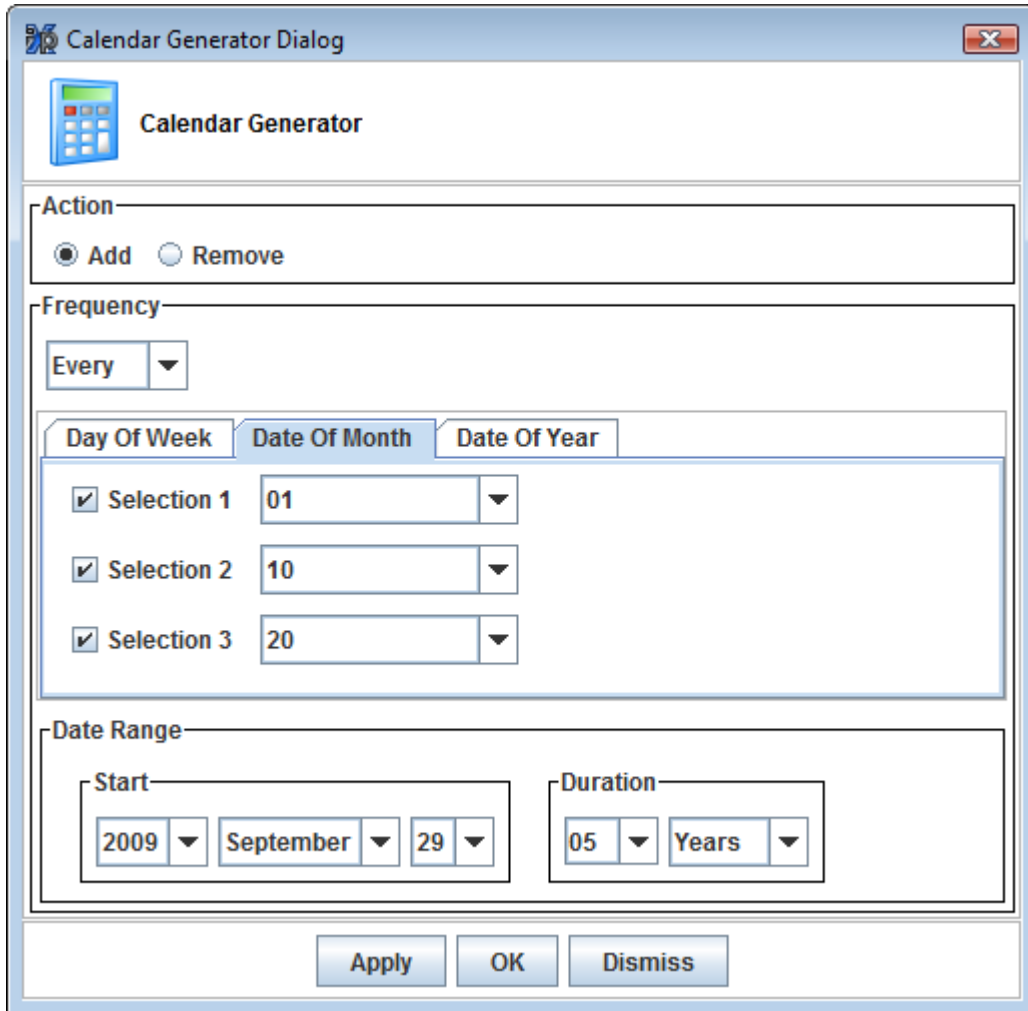













4.6.2 Edit Jobs

The Edit Jobs selection provides a form editor for CA Workload Automation AE Jobs.

The Menu icons provide access to creating, saving, deleting jobs, etc. The pages of the editor are: Basic, Date/Time, Alarm, Execution, Runtime, Resource, Permission, Box, and File Watcher. These pages are described in detail below.

The area at the bottom of the screen shows the JIL (Job Information Language) that will be used to define the job to CA Workload Automation AE.

4.6.2.1 Menu icons

Menu Icon	Functionality
	Create new job
	Copy current job to new name (requires save)
	Save current job
	Save On Alternate Instance—copy this job to a different CA Workload Automation AE instance
	Delete current job—if the job is a box, jobs in the box are not deleted.
	Delete a box—also deletes all jobs inside the box.
	Create a one-time override for the current job.
	Delete a one-time override for the current job.
	Reload job definition from the CA Workload Automation AE database—all unsaved changes will be lost.
	Clear all fields
	Find a job by command, description, machine, name, or owner (also show a list of recently selected jobs)
	Display Help.

4.6.2.2 Basic page

Basic information for a job includes the following:

- Job Name
- The Box the job is in (if any)
- Job Owner (ID to be used when running the job)
- Job Type (cannot be changed)
- Description
- Condition (starting condition(s) of the job)
- Machine

4.6.2.3 Date/Time page

The Date/Time page includes the following:

- Date Conditions check box—must be selected to schedule by date & time
- Date sub-page

Definition Menu

- Run Calendar
- Run Days
- Exclude Calendar
- Time sub-page
 - Times of Day
 - Minutes After Each Hour
 - Run Window
 - Time Zone

4.6.2.4 Alarm page

The Alarm page includes: Maximum and Minimum Run Time alarms as well as the Alarm on Failure check box.

4.6.2.5 Execution page

The Execution page includes the following options:

- Box terminator (for jobs in boxes)
- Job terminator (for jobs in boxes)
- Terminate job minutes
- Delete job hours
- Restart number of times parameter
- Average run time minutes
- AutoHold for jobs in boxes check box

4.6.2.6 Runtime page

On the Runtime page, the standard out, standard error, and standard input files are defined, as well as the profile to be used when running a job.

4.6.2.7 Resource page

Resources include the Maximum Exit Code parameter, the Heartbeat Interval, the Job Load and Job Priority settings (for use with queuing), and the Required Disk Space parameters.

4.6.2.8 Permission page

On this page the permissions for access to the job are defined. Edit and Execute permissions for Group, World, and All Hosts are available.

4.6.2.9 Box page

This page contains parameters that are unique to Box jobs: Box Success and Box Failure conditions.

4.6.2.10 File Watcher page

This page provides parameters that are unique to File Watcher jobs. Minimum File Size and Steady State Interval are the parameters supported here.

4.7 Help Menu



The **Help Menu** enables users to view information about the version of iXp, view the Users and Administration Guide, and view description of all the icons being used for job statuses in the Tree and Console View.

4.7.1 Graphics Help

Select the Graphics Help menu item to view a description of the icons and arrows used in the Views.

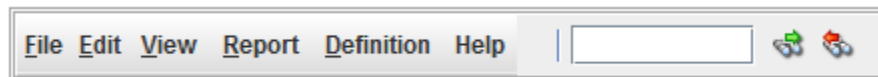
4.8 Quick Find



The box to the right of “Help” on the iXp Menu Bar allow entry of a search string to find jobs. The “next”  and “previous”  icons move the selection to the next job which matches the string in the box.

The order in which jobs are found is controlled by the Tree View order, that is: jobs near the top of the Tree will be found first.

Any job name containing the string entered will be matched (wildcards are not supported because all matching strings will be found). If no jobs have a matching string, the icons are grayed out as shown below:

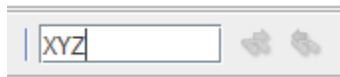

5 iXp TOOL BAR

5.1 Instance Monitor

The **Instance Monitor** button  at the bottom-left corner of the iXp window brings up a dialog box that shows the current state of all the CA Workload Automation AE Instances.

If one or more CA Workload Automation AE Instances are experiencing a database issue, then the icon will change to .

If one or more CA Workload Automation AE Instances have been disabled in iXp, then the icon will change to .

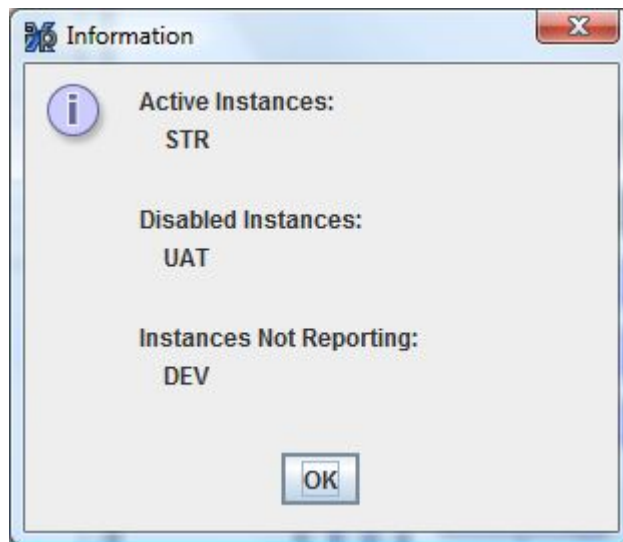

5.2 Alarm Manager

The **Open Alarms** button  at the bottom of the iXp window brings up the **Alarm Manager** dialog box. This button is visible only if the user has been assigned the privilege to view CA Workload Automation AE Alarms.

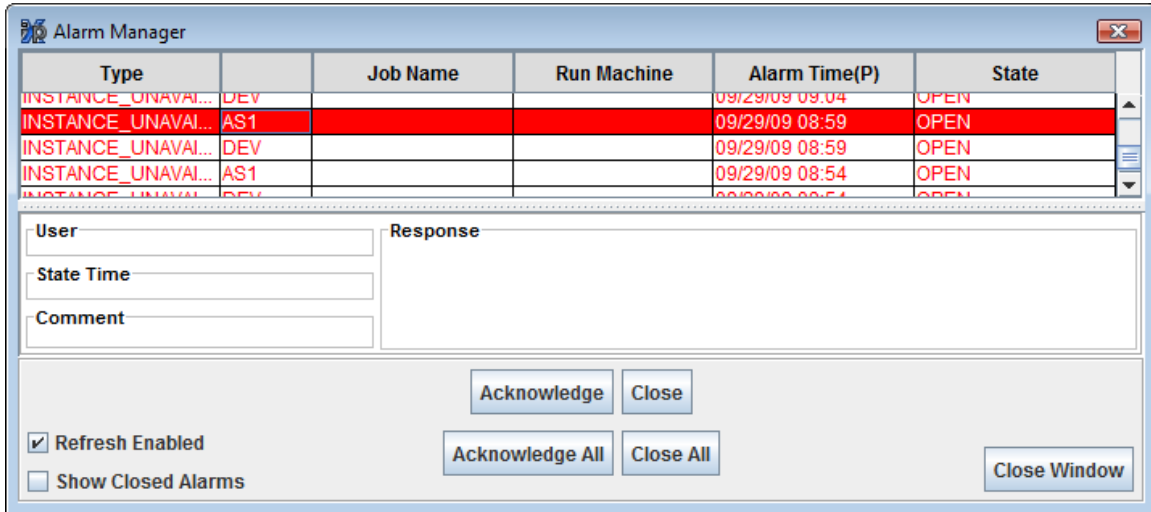

CA Workload Automation AE alarms are in one of three states: Open, Acknowledged and Closed. From the Alarm Manager, Open alarms may be Acknowledged or Closed. All Open Alarms have a red font and a red highlight when selected. Acknowledged alarms may be Closed or Acknowledged again. Closed Alarms may be Closed again, if needed. The Alarm Manager Buttons at the bottom of the Alarm Manager change the state of selected alarm(s), and prompt for a Response.

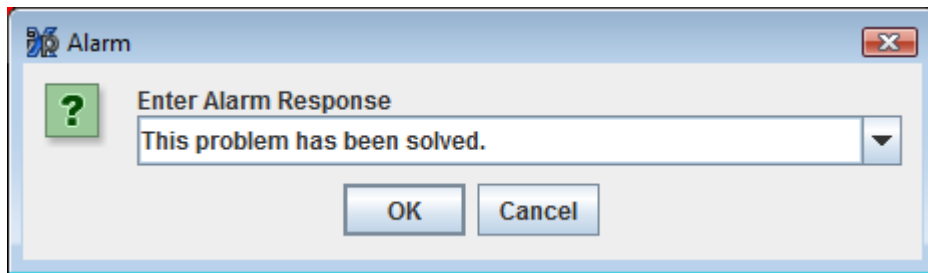

When closing multiple alarms at the same time, a confirmation dialog—shown below—will be shown before the alarms are closed.

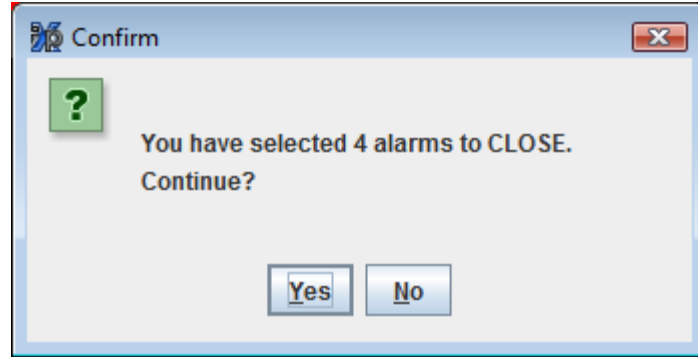

Details for the fields and options in the Alarm Manager are shown below.

BUTTON	DESCRIPTION
Acknowledge	Acknowledge the selected Open alarm(s). If multiple alarms are selected, the Acknowledge button will acknowledge those alarms that are in the Open state. The Enter Alarm Response input box will appear. Type in the desired response text for the alarms, and select OK .
Acknowledge All	Acknowledge all the Open alarms. The Enter Alarm Response input box will appear. Type in the desired response text for the alarms, and select OK .
Close	Close the selected Open or Acknowledged alarm(s). If multiple alarms are selected, the Close button will Close those alarms that are in the Open or Acknowledged state. The Enter Alarm Response input box will appear. Type in the desired response text for the alarms, and select OK .
Close All	Close all the Open and Acknowledged alarms. The Enter Alarm Response input box will appear. Type in the desired response text for the alarms, and select OK .
Refresh Enabled	By default, the Alarm Manager refreshes the alarm data with every client refresh. To prevent the Alarm Manager from automatically refreshing while you are working with it, un-select this option.
Show Closed Alarms	Includes Closed alarms on the Alarm Manager list.

Alarm Manager

Hide Closed Alarms	Removes Closed alarms from the Alarm Manager list.
Close Window	Closes the Alarm Manager dialog.

The information boxes in the Alarm Manager window display the following alarm management information.

INFORMATION BOX	DESCRIPTION
User	The user who Acknowledged or Closed the alarm.
Comment	An attribute of alarm, provided by the CA Workload Automation AE event processor.
State Time	The time of the most recent state transition of the alarm (to state Open, Acknowledged or Closed).
Response	The response input when the alarm was transitioned from Open to Acknowledged, or to Closed. If the alarm has been Acknowledged or Closed multiple times, all the responses entered will be shown.

5.2.1 Job Control Pop-up menu in Alarm Manager

Select an alarm, and right mouse click on it to bring up the Job Control Pop-up menu for the job that generated the alarm.

The Job Control menu functionality is described in the [Job Control](#) section of this document.

Alarm Manager

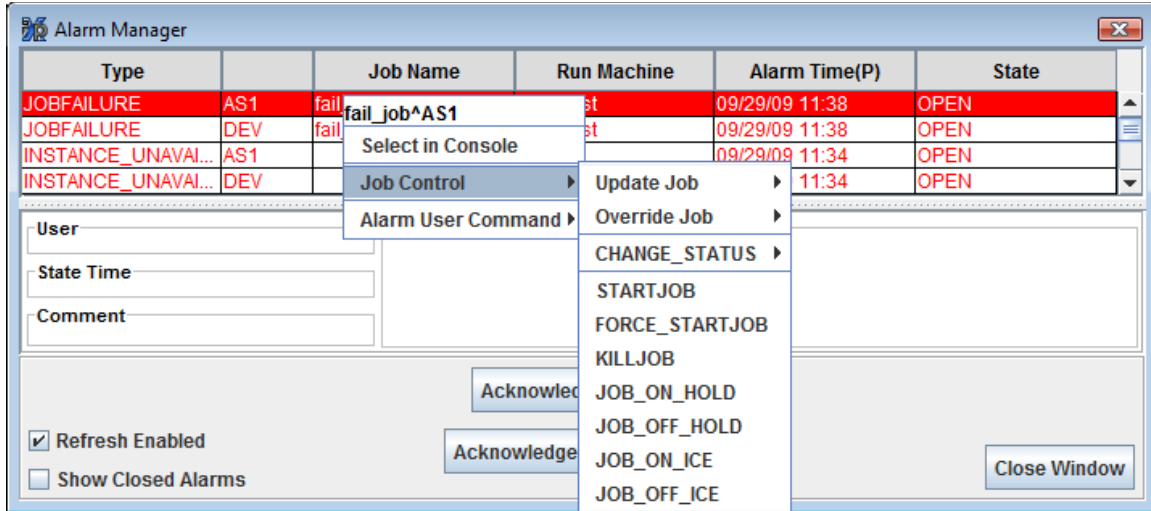

Choose “Select in Console” to highlight the job in all the iXp views. If the selected Alarm Manager job is not in the current iXp job set, a refresh will be executed to bring in the job.

If the Alarm selected is not related to a job, a more limited pop-up menu is displayed:

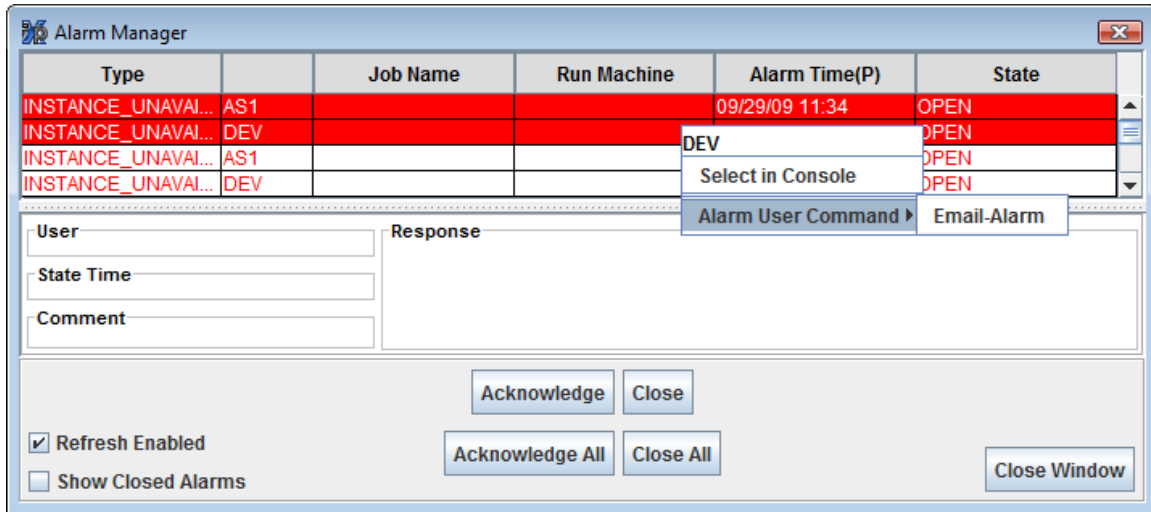

5.2.2 Sort Order in Alarm Manager

Rearrange the listing order in the Alarm Manager by selecting on a column heading with the right mouse button. The sort order selection (box) popup, similar to the one in the Console View, will appear. The columns in this dialog may be moved and resized by clicking and dragging the column headers. The column positioning, sizing and the sort order can be saved by selecting the Save Session Settings option under the File menu item on the main screen.

5.3 Current Filter

The **Current Filter** button at the bottom of the iXp window may be used to change the current filter for the iXp views.



Select a filter from the pulldown list to apply the filter to your current iXp session. iXp will refresh the job views on the client, from the iXp Daemon, using the selected filter.

In the Current Filter pulldown, the list of filters is ASCII sorted (alphabetically with capitals first). Also, iXp creates temporary filters when a user action related to the view is performed (e.g. Critical Path analysis). These temporary filters are named username_number, where username is the name of the logged-on user and number is an incremental number, starting with 0. To save any of these temporary filters, just select the filter and click on the Save icon.

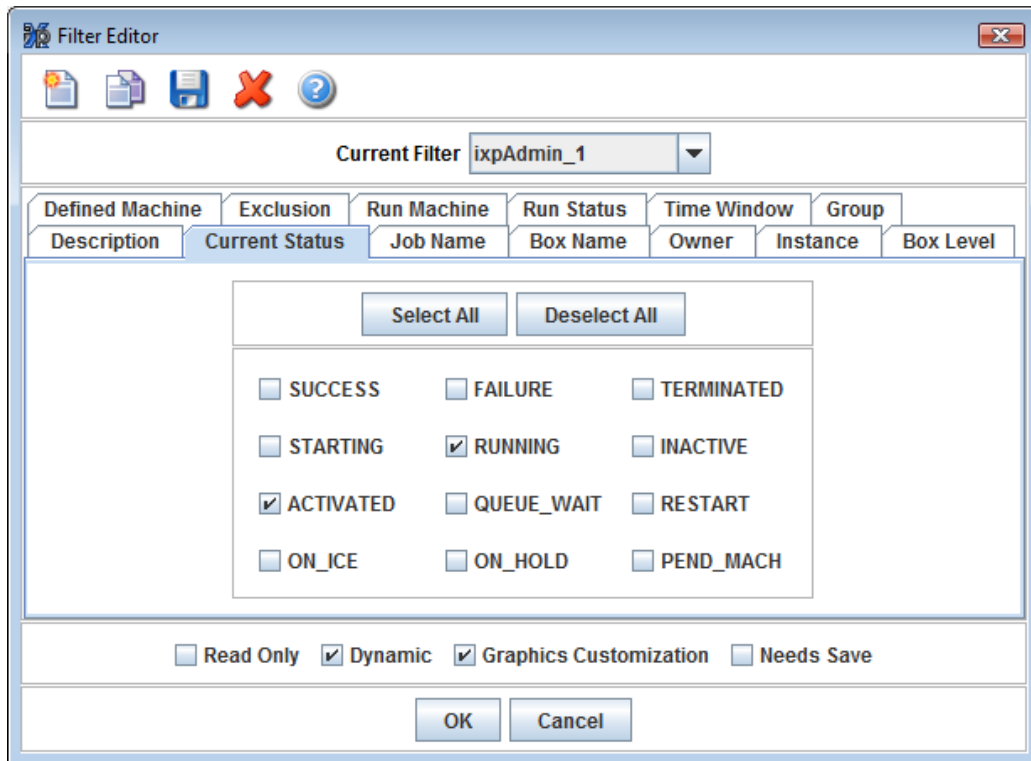

Please remember to save such filters or else they will not be available to the user after logging out or closing the browser. These temporary filters are very useful as users can save the results of any Impact Analysis actions, job selections etc.

5.4 Flow View Buttons

The bottom-right part of the Tool Bar provides buttons for the Job Flow View. These buttons provide the same functionality as the **View ► Flow View** menu options.

iXp Tool Bar	
View Job Definition 	Displays the JIL (autorep -q) for the selected job in a browser window
View Job Detail 	Displays a detailed report (autorep -d) for the selected job in a browser window
View Run Data 	Displays past runs of the job in a pop-up window
Edit Job Definition 	Launch the iXp Job Editor window for the selected job
Expand 	Show the next level of jobs inside a box. (Only available if the selected object is a box or an instance.)
Collapse 	Show only the selected object, not the jobs or boxes inside it. (Only available if the selected object is a box or an instance.)
Zoom Out 	Show more jobs less detail in Flow View. Display changes 10% each click, minimum 1%.
Zoom In 	Show fewer jobs and more detail in Flow View. Display changes 10% each click, maximum 100%.
Fit 	Adjust the size of the Flow View so that all jobs are displayed.
100% 	Adjust the size of the Flow View to 100% (largest, most detail).
Zoom Selection 	Select a specific display magnification from the pull-down or enter a number in the box.
Display/Hide Flow View 	If Flow View is visible, clicking this button will hide Flow View. If Flow View is hidden, clicking this button will display Flow View.
Resume Refresh 	Resume regular automatic status refresh
Pause Refresh 	Stop automatic status refresh
One-time Refresh 	Manually refresh job information

OK

6 JOB FILTERS

6.1 Filters Defined

There are two kinds of filters in iXp. **Attribute Filters** limit the job data that is sent back, according to specified job attributes. **Job Dependency Filters** limit the iXp views according to specified job dependencies.

Users have access to two types of filters, from the *Current Filter* Selection list.

- 1) “Out of the box” filters provided by iXp. These include several Job *Attribute Filters*.
- 2) “User-defined” filters are owned by the user who defined them, and are configurable by him/her. These include temporary filters created when jobs are added to the view.

The Current Filter appears on the Current Filter button at the bottom of the iXp window, and on the *Filter Editor*.

All filters are applied after the user security filters have been applied. Thus, applying the “No Filter” as current filter will show all jobs that the user is allowed to see.

6.1.1 Attribute Filters

Job Attribute Filter configurations may be edited, or created, with the *Filter Editor*. Attribute Filters can use CA Workload Automation AE job attributes to further define or limit the views in iXp.

“Out of the box” Attribute Filters provided by iXp include the following.

iXp Job Attribute Filter Name	Description
Level Zero Filter	Includes all instances in the site and jobs that are not in boxes and box jobs at level zero i.e. jobs within a box are not shown.
Running Filter	Includes jobs that have a current status of STARTING, RUNNING or ACTIVATED.
Exception Filter	Includes jobs that have a current status of FAILURE

	or TERMINATED.
Instance Filter	Only the Site and Instance icon are shown. No jobs are shown.
Site Filter	Only the Site icon is shown. No instance icons or jobs are shown.
No Filter	Shows all instances and all jobs within all instances.

6.1.2 Job Dependency Filters

Job Dependency Filters are selected from the *Job Tools Popup* menu. Job Dependency filters can be applied in two ways, **Update Filter** and **New Filter**. Update Filter will apply the selected filter to the existing view. This may result in an addition of new jobs to match the filter but will not result in a removal of any jobs from the existing view. New Filter will clear the existing view, create a temporary filter based on the username and show the jobs that match the selected filter. **See the *Job Dependency Filters definitions*** in the Job Tools Popup section of this document.

6.2 How Filters Work

When the iXp Daemon receives a request for a read operation, such as a refresh, job filters are applied to the iXp Data before returning jobs data to the Client, as follows.

- 1) The iXp Daemon first applies the appropriate security read filter to the site data, returning a security-filtered site. (The request from the iXp Client always comes identified with the specific user, for individualized response from the iXp Daemon.)
- 2) Then the user-specified filter is applied to the security-filtered site data, and the data are sent to the client.

6.2.1 Filter Logic Sequence

The filter saved to the iXp Daemon, for the specific iXp Client, is applied to the security-filtered site, according to the following filter logic.

- 1) The Job *Attribute Filter* or *Job Dependency Filter* reduces the view according to the specified attributes. Then any Exclusion Post-Process attributes result in special eliminations.

How Filters Work

- 2) User-modifications to the views are applied, including Expand, Collapse, Expand All, Hide, Update Filter, Find Job by Name, Predecessor and Successor (as chosen from the Job Detail View).
- 3) Inclusion of the complete Box Ancestry for all jobs returning to the iXp Client is always the final filtration step on the iXp Daemon.
- 4) New jobs, arriving to the Client after graphics customization, are positioned logically by iXp, post-process.

6.2.2 Example Filtration Sequence

- 1) Suppose one applies the Level Zero Filter: only the first level Box Jobs appear in the view.
- 2) Then, through the *Update Filter* function on the job tools popup menu, apply a Critical Path Filter on one of those jobs. This will create a new filter that belongs to you, and will return all the dependency-related jobs for that selected job, also leaving the other first level box jobs.
- 3) Then use the *Find Job by Name* function on another, third level Box Job. This returns that job and its parent, in addition to the other jobs.]
- 4) The iXp Client will expand the box graphics in the Job Flow View and insert the newly returned jobs.

6.3 Filter Editor

The **Filter Editor** can be brought up by the Edit ► Edit Filter menu pick, or by clicking on Filter Value in the Preference Editor. Use the Filter Editor to adjust the configurations of the Job Attribute Filters. The iXp Daemon sends to the iXp client only jobs that pass the *Current Filter*.

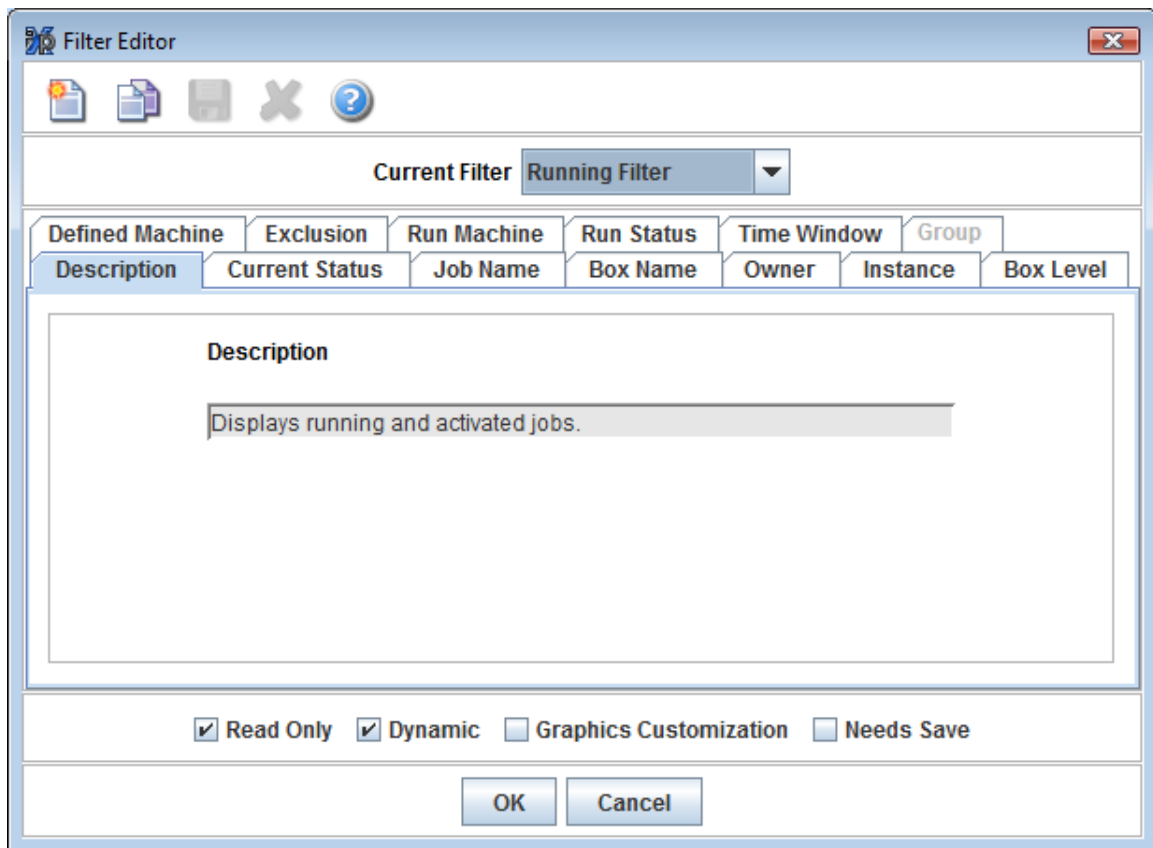

To edit a Job Attribute Filter:

- 1) Select the filter from the **Current Filter** menu.
- 2) Select the filter attribute you desire to edit from among the twelve tabs: Description, Current Status, Job Name, Box Name, Owner, Instance, Box Level, Defined Machine, Exclusion, Run Machine, Run Status, and Time Window.
- 3) Edit the properties of that tab in the dialog box. For Instance, Run Machine, Defined Machine, Exclusion, Job Name, Box Name and Owner, use the **Insert** and **Delete** buttons to edit the **Expressions**. In Box Level and Time Window, slide the level pointer. In Current Status and Run Status, check or uncheck Statuses to filter. In Description,

Filter Editor

type your description directly in. Here is an example of entering wild card expressions:

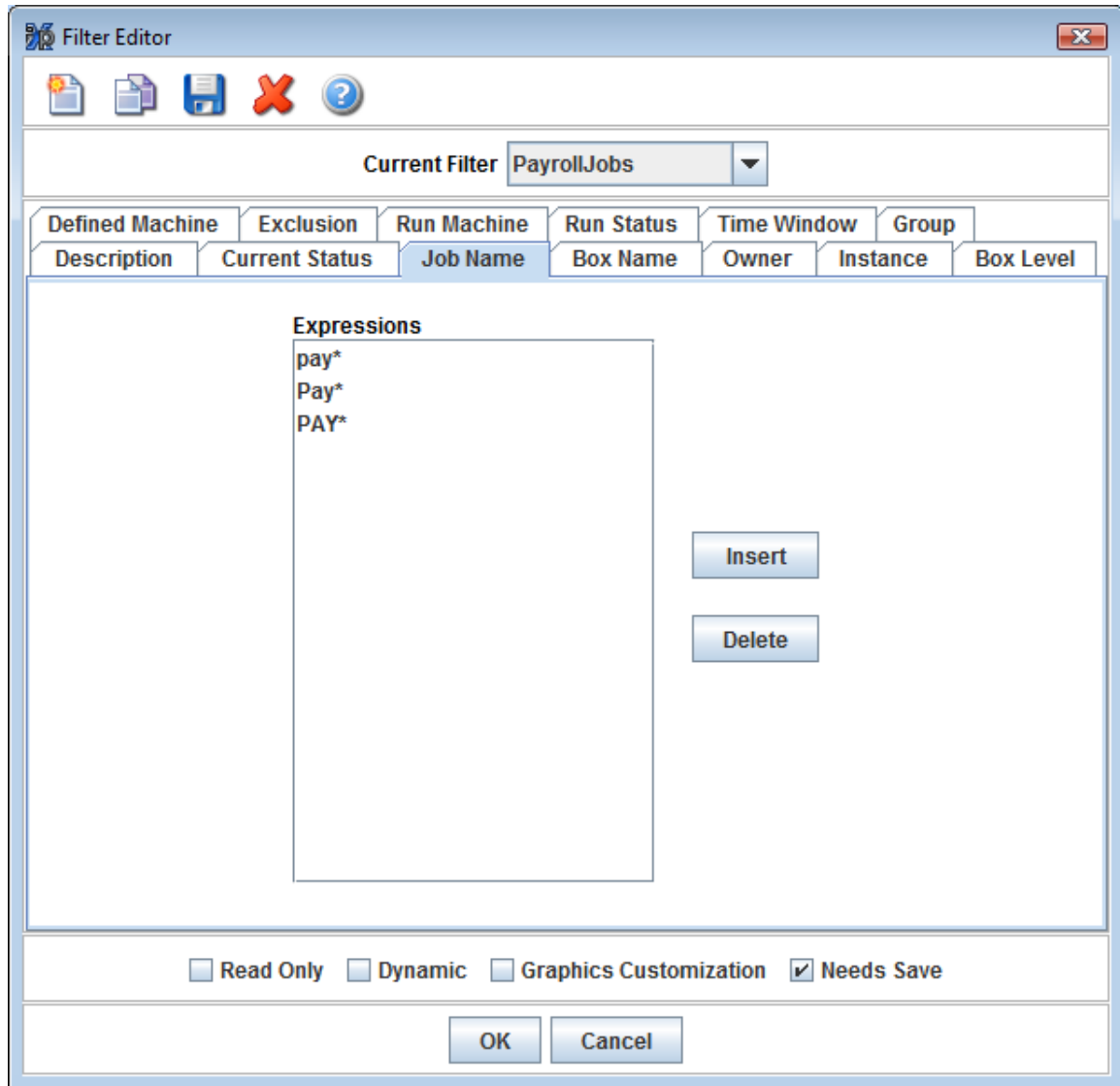

The above expressions will return all jobs having Job Name that starts with Pay or pay. **NOTE:** for JOB NAMES, ^ is a special character that defines a CA Workload Automation AE Instance, as in Job_A*^ACE...

- 4) Select **OK** to save your edits and close the Filter Editor window.
- 5) Click on the Save icon in the Filter Editor, or in the Preference Editor, to save your filter edits.

Filter Editor Tabs:

Filter Attribute	Description
Instance	CA Workload Automation AE Instance names, like "ACE", or wildcard expressions like "A*". The absence of any entries means no jobs will be excluded based on instance.
Box Level	Box Level is the maximum number of box levels that will satisfy the filter. All jobs of a higher box level will be excluded.
Run Machine	Run Machine entries pass only jobs having one or more run records in the specified list of statuses. Entries may be a string like "pluto" or a wildcard expression like "pl*". The absence of any entries means no jobs will be excluded based on run machine. Only jobs having one or more historical run records on a run machine (or virtual machine) will pass the filter. If a job satisfies a filter, its box ancestry will also be included.
Run Status	See screen shot below. The filter includes all ancestors of jobs satisfying this filter, regardless of the ancestors' Run Statuses. The absence of any Run Status selections means no jobs will satisfy the filter. If no Run Status filtration is desired, select all statuses.
Time Window	"Future Hours" and "Past Hours" set bounds on the Run Status and Run Machine filter tabs. Choosing "Ignore" for Past Hours means no recent run history is required to pass the filter. Choosing "Ignore" for Future Hours means no future execution is required to pass the filter.
Defined Machine	Each list entry can be a string like "pluto" or a wildcard expression like "jup*". The absence of any entries implies that no jobs will be excluded based on the JIL "machine:" specification. A job satisfies the filter if it has at least one machine in its JIL "machine:" definition that matches any of the filter's wildcard expressions. Note that if a job satisfies a filter, its box ancestry will also be included.
Exclusion	Exclusion expressions are performed after all other filter expressions. If a job_name satisfies an exclusion expression that job, and if a box all of its descendants,

	will be discarded. Expressions may be a string like "job_ABC" or a wildcard expression like "job_A*". The absence of any entries means that no jobs will be filtered based on Exclusion expressions.
Description	Use the Description field to document the filter.
Current Status	Only jobs with Statuses that are selected by a check mark will satisfy the filter. If no statuses are checked, no jobs will pass the filter. If all Statuses are checked, no jobs will be excluded based on status.
Job Name	Each list entry can be a job_name like "Job_A" or a wildcard expression like "Job_A*". The absence of any entries implies that no jobs will be excluded based on job_name. Note that "^" is a special character for delimiting instances. "Job_A" is equivalent to "Job_A^*".
Box Name	Each list entry can be the name of a Box Job. The name supports wildcard expressions. The filter will return all Box Jobs that match the name expressions and all the jobs within them.
Owner	Only jobs with owner that match these expressions will pass the filter. Entries may be a string like "root@pluto" or a wildcard expression like "root@*". The absence of any entries means no jobs will be excluded based on owner.
Group	Groups to be included in the Filter.

Filter Editor Check Boxes:

Check Box	Description
Read Only	Indicates this filter is not owned by the current user and cannot be modified.
Dynamic	Indicates this filter is modified by job run data.
Graphics Configuration	Indicates additional drill-down or drag-n-drop actions are associated with this filter. This is a deprecated setting which may be enabled again in a future release.
Needs Save	Indicates that filter configuration changes have not yet

Filter Editor

been saved to the iXp Daemon.

Filter Editor, showing Run Status selection:

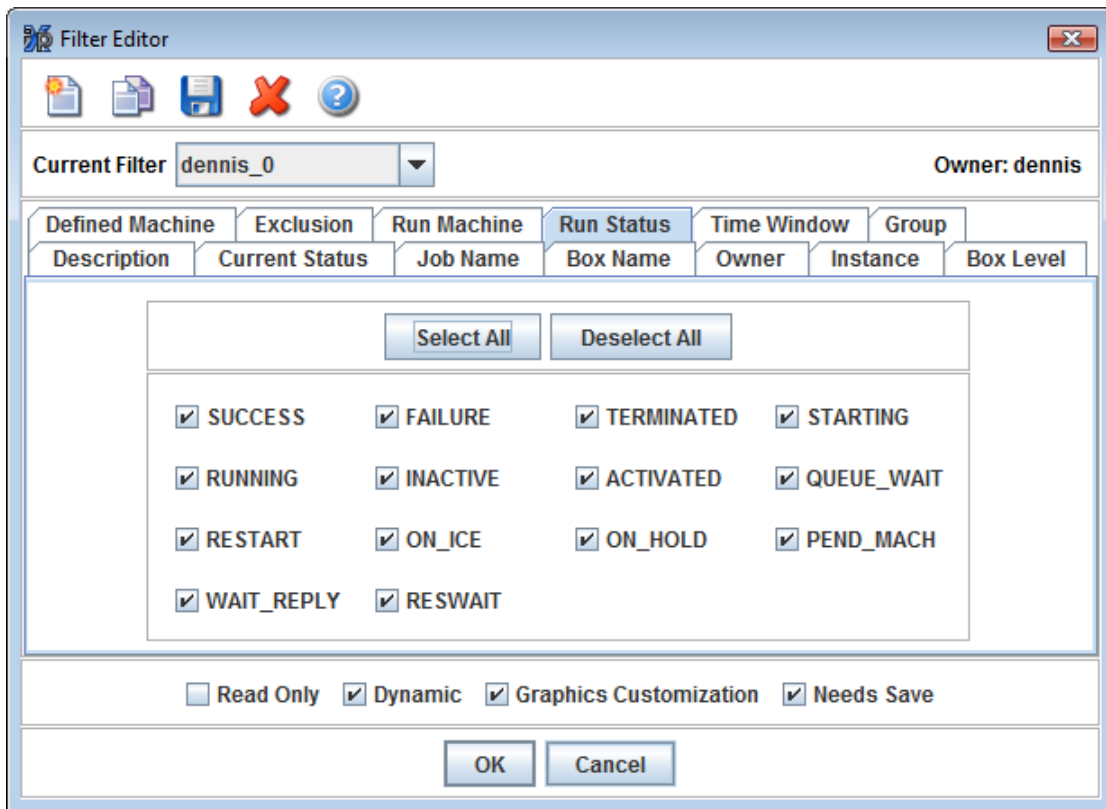

6.3.1 Filter Editor File Menu



Click on the New Filter icon to create a new filter.

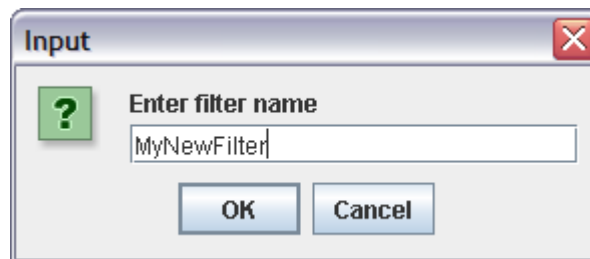

Click on the Copy Filter icon to bring up an input box to save the specified filter configurations under a new filter name.

Filter Editor



The Save icon saves your filter.



The Delete Filter icon saves a copy of the selected filter to the iXp Server, and then deletes it. If you like, you can restore your deleted filter by asking the Administrator to rename your saved filter file.

7 JOB TOOLS POPUP

A popup menu for job tools can be activated by right-clicking on a job in any of the views. The same menu can also be activated by right-clicking on an Instance icon in the Tree or Job Flow View. This menu offers tools for navigating the job streams, issuing events on jobs, updating job definitions, generating job dependency filters, running user commands and viewing job information.

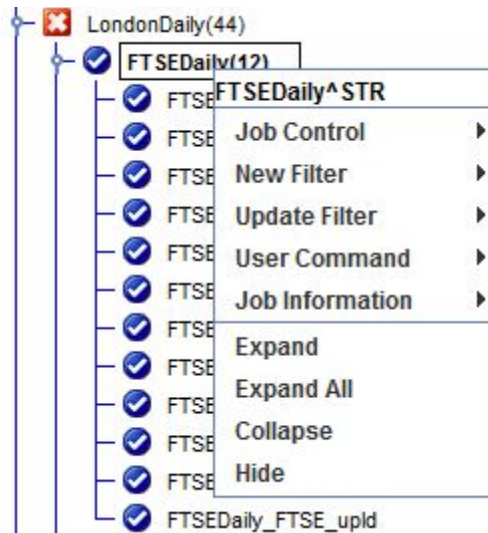

7.1 Expand, Collapse, and Hide

The **Expand**, **Expand All** and **Collapse** menu items are shown when either a Box job or an Instance is selected. These three options provide an easy way to traverse the job streams. Box jobs or Instances would either be expanded by just one additional level (**Expand**) or expanded to show all the jobs within them (**Expand All**). A Box Job or an Instance could also be collapsed to show just that Box job or Instance but not any of the jobs within them (**Collapse**). The **Hide** menu option could be applied to any job or Instance. Activating this item removes the selected job/Instance and also all of the jobs within them, from all of the Views.

Popup Menu Pick (to Include/Remove jobs)	Description
Expand	Includes the children of the Box Job into the views.
Expand All	Includes all progeny of the Box Job (its children, their children, and so forth) into the views.
Collapse	Removes all progeny of the Box Job (its children, their children, and so forth) from the views.
Hide	Removes the selected job, and all its progeny, from the view. NOTE: You cannot Hide a Site.

7.2 Job Control

The **Job Control** sub-menu items provide the capability to send events, create job definition overrides, and update job definitions. The job definition updates and overrides can be submitted through a dialog that accepts job definition attributes in JIL format. That dialog also shows the current job definition in JIL format, for reference. The dialog also performs a syntax check on the JIL submitted, and warns on erroneous, invalid and incomplete data. This menu option will only show those choices for which you are authorized.

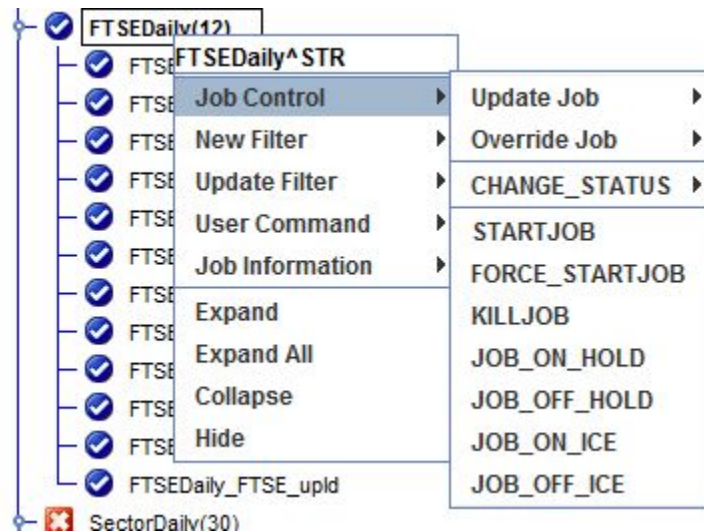

7.2.1 Update Job

The **Update Job** menu item launches a dialog from which a user can update the job definition. The dialog allows users to update any attribute of the job, except the **owner** field.

7.2.2 Override Job

The **Override Job** menu item provides a dialog from which a user can submit a one-time job override to CA Workload Automation AE. For one-time overrides, CA Workload Automation AE only allows a selected job attributes to be modified. Hence, the iXp dialog may generate error messages if the one-time override is issued for invalid job attributes.

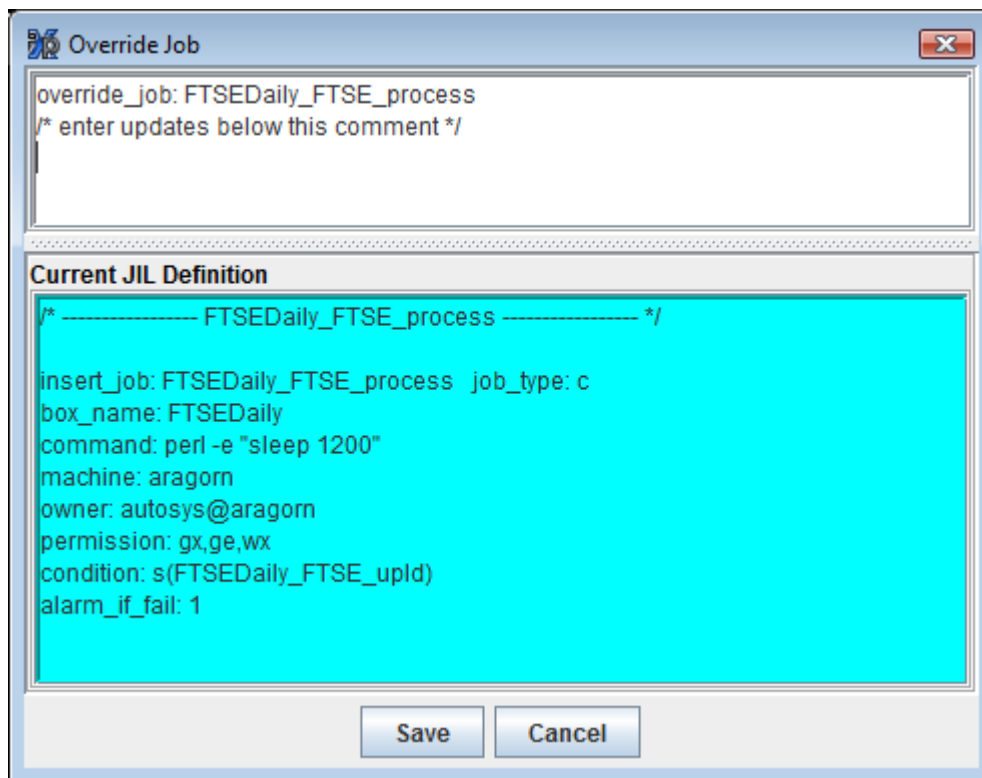

7.2.3 Change Status

The rest of the Job Control menu options allow users to send events to CA Workload Automation AE for the selected job(s). The **CHANGE_STATUS** option has a sub-menu that provides a selection of job statuses.

New Filter and Update Filter

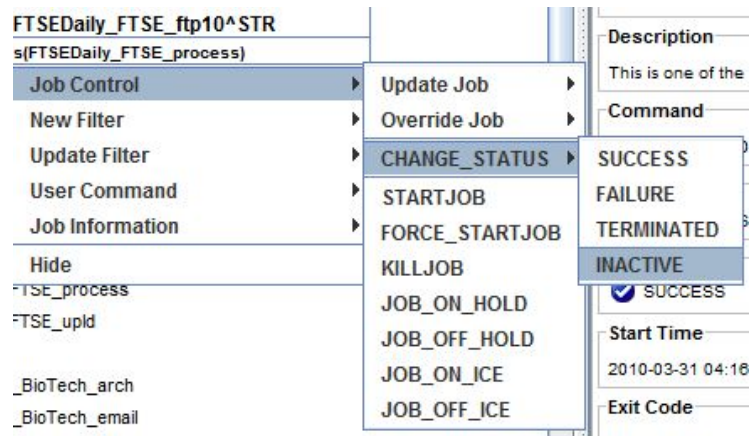

When an event is selected, users can also provide a comment that could be used for audit purposes. The comment is not mandatory and hence the text area for the comment could be left blank. Every time iXp issues an event to the CA Workload Automation AE database, the iXp username is inserted as a part of the comment, even if the comment is left blank. This provides an audit trail of all events performed via iXp.

When a particular sendevent is selected, the confirmation dialog also allows users to type in the comment to be associated with that job and event.

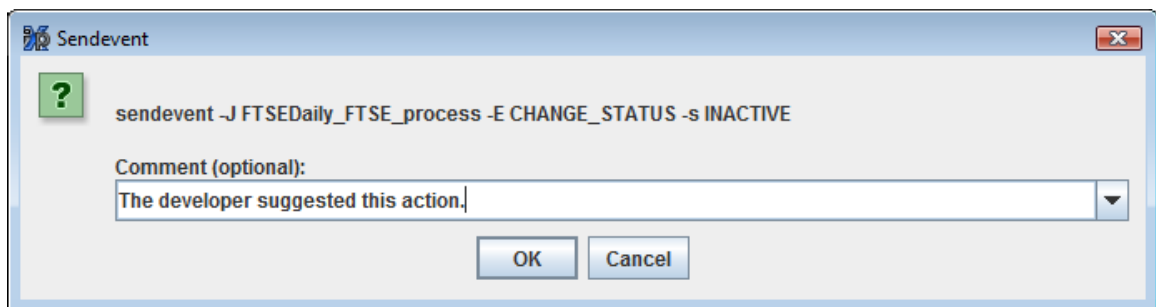

7.3 New Filter and Update Filter

The **New Filter** and **Update Filter** options allow the creation of Job Dependency Filters. New Filter always creates a new temporary filter with the selected Job Dependency criteria. Update Filter always updates the existing filter with the selected Job Dependency criteria. Once the filter is set the preferred way, it can be saved with a new name from the [Filter Editor](#).

Select **New Filter** to create a new filter that will appear on the Set Filter list.

New Filter and Update Filter

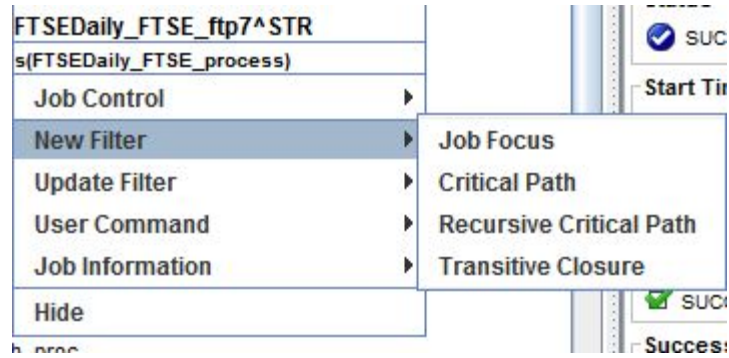

Choosing a New Filter will apply a *Job Dependency Filter* to the selected job (named Payroll_CalcBonusPay1 in this example).

Select **Update Filter** to return the **union set** of jobs for a *Job Dependency Filter* on the selected job, together with the existing filter. The Update Filter item has the same choices as the New Filter option.

For example, choosing an Update Filter of **Job Focus** will add the child and parent dependency relations of the selected job to the view and will not remove the other jobs.

7.3.1 Job Dependency Filters definitions

Job Dependency filters can be applied via Update Filter and New Filter. Update Filter will apply the selected filter to the existing view and may result in an addition of new jobs to match the filter but will not result in a removal of any jobs from the existing view. New Filter will clear the existing view, create a temporary filter based on the username and show the jobs that match the selected filter.

Dependency Filter Name	Description
Job Focus Filter	Filters the iXp views to show a job and its immediate predecessors and successors.
Critical Path	Focuses on a job and then follows predecessor and successor relationships (dependency relationships) from that job, as far as the dependency relationships can be traced in the job stream.
Recursive Critical Path	Performs a critical path filter on the job, and on all its ancestors and all its progeny. This yields all the extended ancestor and progeny relationships (Box relationships) to the selected job, and all the extended predecessor and successor

New Filter and Update Filter

	relationships (dependency relationships) to each of those jobs.
Transitive Closure	Follows all Box and dependency relationships in both directions, throughout the CA Workload Automation AE Job structure. First a Recursive Critical Path filter is applied to the selected job, then a Recursive Critical Path filter is applied to the resulting jobs, and so forth through the job stream. Transitive Closure on any job in the set of jobs returned by the Transitive Closure filter has the useful property that the filter applied to any one selected job returns the same set of jobs as for any other job in the set. The Transitive Closure filter can be useful for understanding where the partitions are in your job stream, hence for designing more modular job streams, for rapid failure recovery.

7.4 User Command

The **User Command** menu option provides quick access to all user commands of type job. When expanded, this menu item shows all the job user commands that are available for execution. The list of commands would be same as that found under the *File*►*User Command*►*Job* menu item.

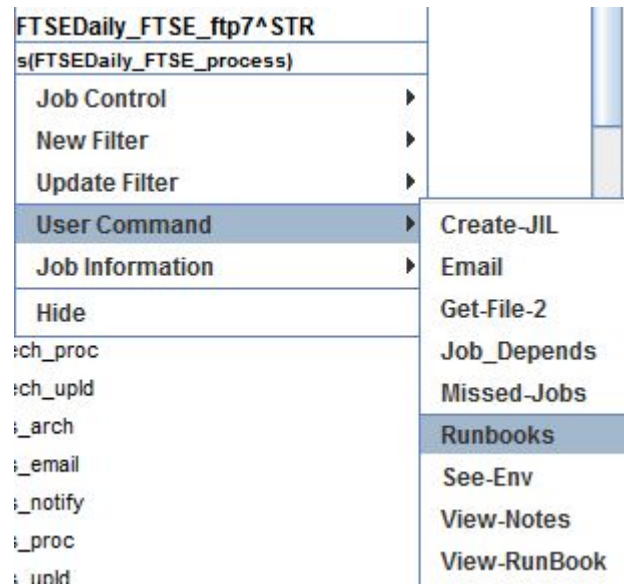

7.5 Job Information

The **Job Information** menu option has five (5) sub-menu options that allow users to retrieve the Job Definition, report on the last Job Run, View all the historical and forecasted runs of the selected job, retrieve the Log files created by the job and CA Workload Automation AE when the job ran on the Remote Agent machine (if the iXp Agent is installed on that machine), and view the calendars associated with the job.

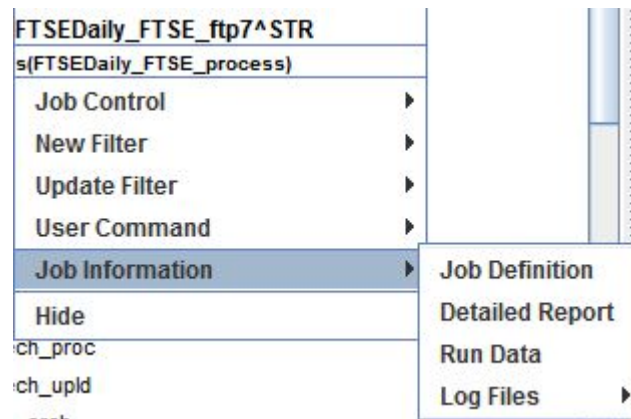

Select **Job Definition**, **Detailed Report**, **View Run Data** to view the Job Information for the selected job. Select the **Log Files** sub-menu item to see a list of files that you can retrieve for the last job run. Select the **Calendars** sub-menu to see the Run or Exclude Calendar for a job.

7.5.1 Job Definition

Select **Job Definition** to return the JIL definition of the job. This is by means of a call to the CA Workload Automation AE command:

```
autorep -J jobname -L 0 -q
```

An CA Workload Automation AE Remote Agent, installed with configuration for all instances monitored through iXp, is required to view Job Definitions.

7.5.2 Detailed Report

Select **Detailed Report** to return the event history of the most recent run of the job. This is by means of a call to the CA Workload Automation AE command:

```
autorep -J jobname -r 0 -d
```

Job Information

A CA Workload Automation AE Remote Agent, installed with configuration for all instances monitored through iXp, is needed to perform a Detailed Report.

These reports are returned in a Web browser.

7.5.3 Run Data

The Run Data option provides a listing of all the historical and forecasted runs for the selected job. The runs are listed in descending order with the most recent run at the top. The most recent run (or the current run if the job is running) has the run-number 0. Hence, the oldest run has the highest run-number. All forecasted runs are marked with “FUTURE”, rather than numbers. This provides a clear indication about which runs are forecasted and which are actual.

Selecting **Run Data** returns a report similar to the following:

	Status	Start Time	End Time	Duration	Exit Code	Run Machine
0	SUCCESS	2009-04-14 18:09:09 MDT	2009-04-14 18:10:50 MDT	01m41s	0	rover
1	SUCCESS	2009-04-10 03:05:19 MDT	2009-04-10 03:07:00 MDT	01m41s	0	rover
2	SUCCESS	2009-04-09 12:03:20 MDT	2009-04-09 12:05:01 MDT	01m41s	0	rover
3	SUCCESS	2009-04-09 11:34:47 MDT	2009-04-09 11:36:28 MDT	01m41s	0	rover
4	SUCCESS	2009-04-06 12:03:19 MDT	2009-04-06 12:05:00 MDT	01m41s	0	rover
5	SUCCESS	2009-04-06 11:11:51 MDT	2009-04-06 11:13:32 MDT	01m41s	0	rover
6	SUCCESS	2009-04-03 12:03:19 MDT	2009-04-03 12:05:01 MDT	01m42s	0	rover
7	SUCCESS	2009-04-03 11:22:22 MDT	2009-04-03 11:24:03 MDT	01m41s	0	rover
8	SUCCESS	2009-04-02 12:03:20 MDT	2009-04-02 12:05:03 MDT	01m43s	0	rover
9	SUCCESS	2009-04-02 10:21:29 MDT	2009-04-02 10:23:10 MDT	01m41s	0	rover
10	SUCCESS	2009-04-01 11:34:07 MDT	2009-04-01 11:35:48 MDT	01m41s	0	rover
11	SUCCESS	2009-03-24 12:12:39 MDT	2009-03-24 12:14:19 MDT	01m40s	0	rover

RUN DATA COLUMN	DESCRIPTION
First column	Job run identifier number, as used in the CA Workload Automation AE command <code>autorep -j job_name -r run_number</code> .
Status	Status of the job for the specific run of the job.
Start Time	Time the run of the job started.
End Time	Time the run ended.
Duration	End Time – Start Time.
Exit Code	Exit Code returned for the execution of the job run.

7.5.3.1 View Detail

If you want to see the detailed report (autorep -d) on any run, just select that run in this dialog and click on this button.

7.5.3.2 Create Report

Once the desired runs have been imported in the Run Data dialog, an HTML report that lists those runs can be created by selecting this option. The report will be shown in a web browser. This feature enables users to print, email and save the run report for any job.

Invent_ProcBarrels1^VS2

Report Generated At 01/24/03 14:55
 Start Time 01/17/03 03:49
 End Time 01/17/03 21:10
 Total No. Of Job Runs 35
 Total No. Of Jobs In Failure 0
 Total No. Of Jobs In Terminated 0
 Total No. Of Rows Returned 35/35

Job Name	Start Time	End Time	Total Duration	Status	Exit Code	Machine Name
Invent_ProcBarrels1^VS2	01/17/03 21:09	01/17/03 21:10	00m31s	SUCCESS	0	venus
Invent_ProcBarrels1^VS2	01/17/03 20:39	01/17/03 20:40	00m31s	SUCCESS	0	venus
Invent_ProcBarrels1^VS2	01/17/03 20:10	01/17/03 20:10	00m31s	SUCCESS	0	venus
Invent_ProcBarrels1^VS2	01/17/03 19:40	01/17/03 19:40	00m31s	SUCCESS	0	venus
Invent_ProcBarrels1^VS2	01/17/03 19:09	01/17/03 19:10	00m31s	SUCCESS	0	venus
Invent_ProcBarrels1^VS2	01/17/03 18:39	01/17/03 18:40	00m31s	SUCCESS	0	venus
Invent_ProcBarrels1^VS2	01/17/03 18:09	01/17/03 18:10	00m31s	SUCCESS	0	venus
Invent_ProcBarrels1^VS2	01/17/03 17:39	01/17/03 17:40	00m31s	SUCCESS	0	venus
Invent_ProcBarrels1^VS2	01/17/03 16:40	01/17/03 16:40	00m31s	SUCCESS	0	venus
Invent_ProcBarrels1^VS2	01/17/03 16:10	01/17/03 16:10	00m31s	SUCCESS	0	venus
Invent_ProcBarrels1^VS2	01/17/03 15:39	01/17/03 15:40	00m31s	SUCCESS	0	venus
Invent_ProcBarrels1^VS2	01/17/03 15:10	01/17/03 15:10	00m31s	SUCCESS	0	venus
Invent_ProcBarrels1^VS2	01/17/03 14:39	01/17/03 14:40	00m31s	SUCCESS	0	venus

7.5.4 Log Files

The **Log Files** sub-menu displays a list of files that you can retrieve for the last job run of the selected job. This menu option is visible only if the privilege to view Job Log files or Job Script files has been assigned to you.

Job Information

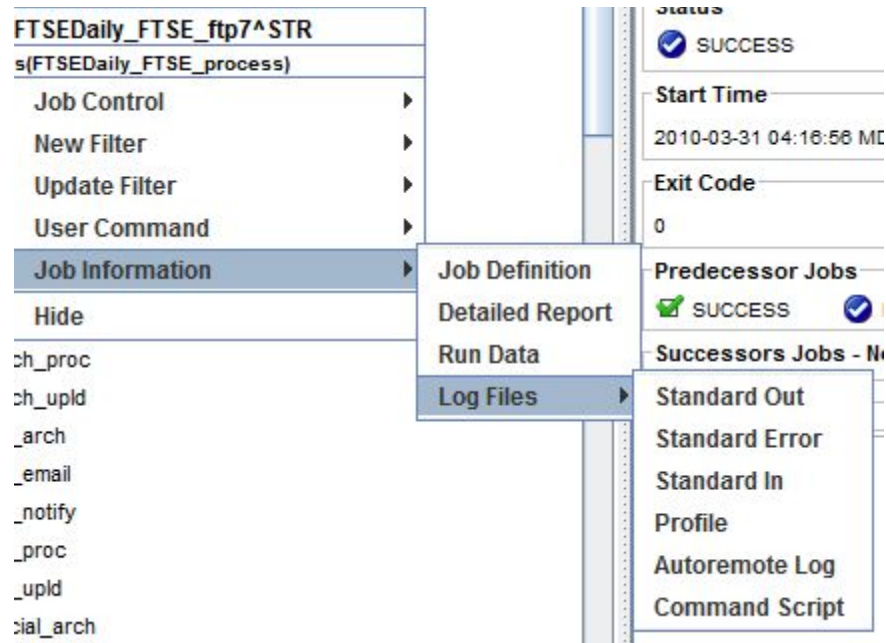

You can retrieve the STDOUT, STDERR, STDIN, Job Profile, and Remote Agent log for the last job run. If any of these files are not present on the Remote Agent machine, the iXp Client will notify you. Since all of these files reside on the Remote Agent machine, the iXp Agent has to be up and running on that machine in order for the iXp Client to show the files for jobs running in CA Workload Automation AE r11 or older versions.

The iXp Client will display the contents of the requested files in a web browser window. This way you can search for text, email, or print the contents of the file.

Tip: If the iXp Agent is not running, then the iXp Client will display an error indicating this condition. If the iXp Client displays a Process Timeout error, you can try to retrieve the log again.

7.5.4.1 STDOUT, STDERR, STDIN

Select the **Standard Out**, **Standard Error**, or **Standard In** option to view these files. The iXp Daemon will extract the file name as defined to the job and resolve any Substitution, Global, or Environment variables in the file name before retrieving the file. If the file name is based upon variables that can have dynamic values (e.g. the RUN_NUM, NTRY of a job, the date when the job ran etc.), then the iXp Daemon will use information from the last run of the job to determine the value of such variables.

Job Information

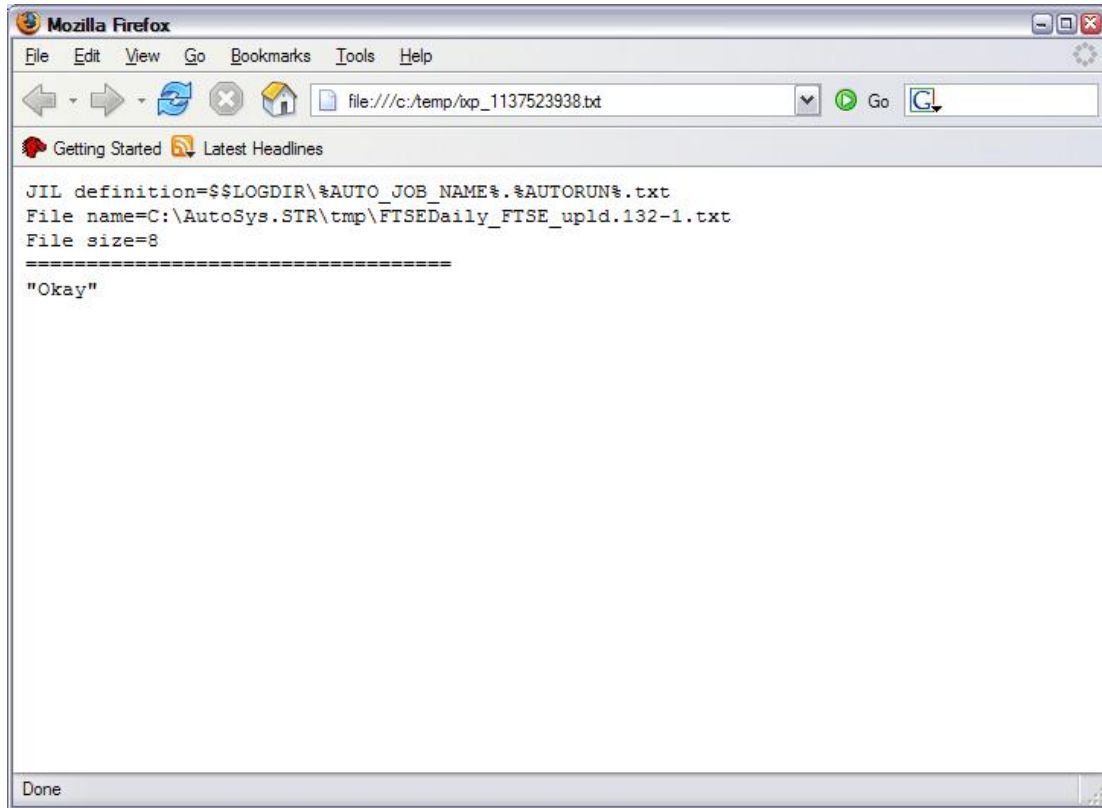

```
JIL definition=${LOGDIR}\%AUTO_JOB_NAME%.%AUTORUN%.txt
File name=C:\AutoSys.STR\tmp\FTSEDaily_FTSE_upld.132-1.txt
File size=8
=====
"Okay"
```

The output of the STDOUT file above shows that the job is defined to create the STDOUT file based on a Global Variable called “LOGDIR” and the standard CA Workload Automation AE Environment variables called “AUTO_JOB_NAME” and “AUTORUN”. The output from iXp Client shows the resolved name of the file, after the appropriate values were plugged in for the variables used.

7.5.4.2 Job Profile

Select the **Profile** menu option to view the file that has been assigned to the job profile field in the job definition. **This functionality is available for Unix jobs only.**

Job Information

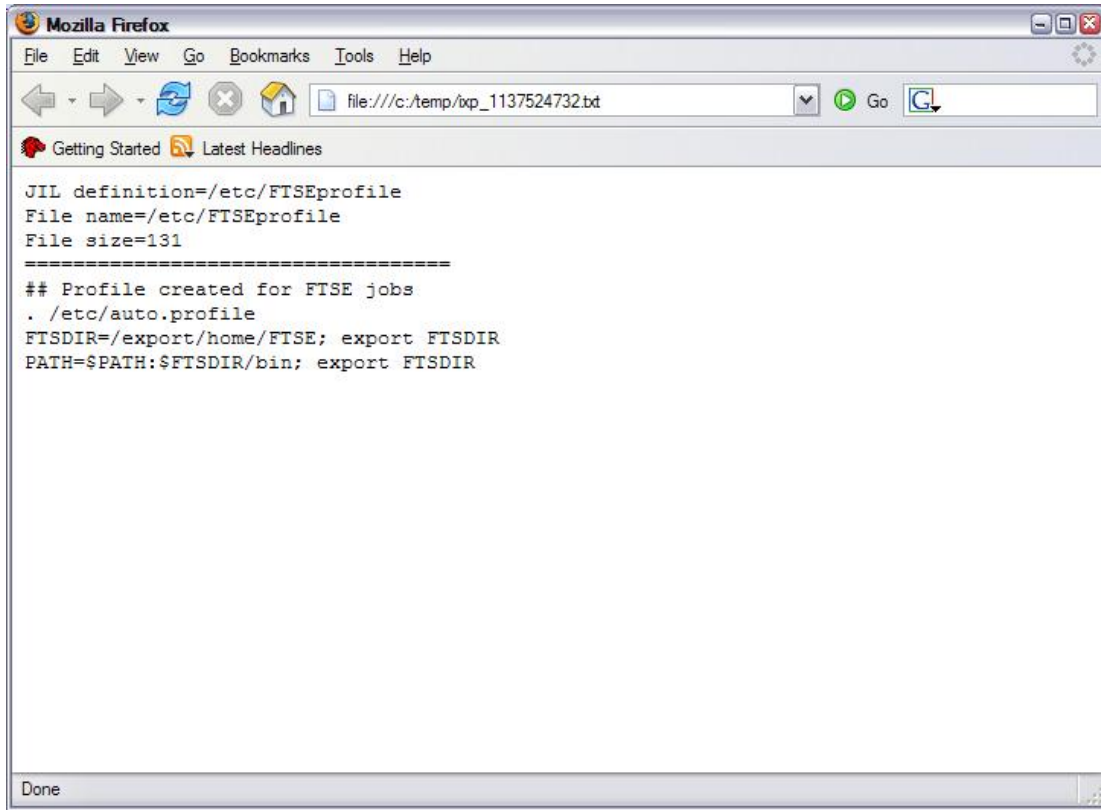

7.5.4.3 Remote Agent Log

Select the **Autoremove Log** option to view the Remote Agent Log file. In most cases, CA Workload Automation AE is setup to purge the Remote Agent Log when the job ends in a `SUCCESS`. Hence, this functionality may work only with jobs in a `FAILURE` or `TERMINATED` status.

For CA Workload Automation AE version r11 or older, if the iXp Agent is unable to find a file, the web browser window will show that message. The window will also show the fully qualified name of the file that the iXp Agent attempted to retrieve.

Job Information

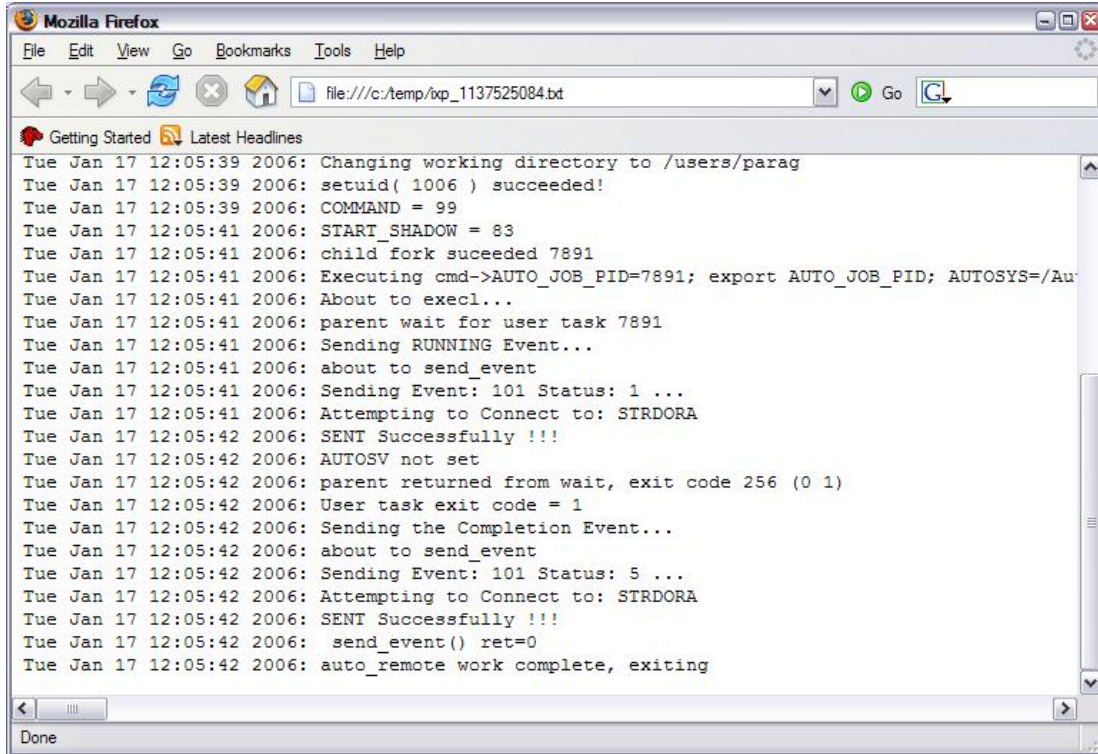

```
file:///c:/temp/xp_1137525084.txt
Getting Started Latest Headlines
Tue Jan 17 12:05:39 2006: Changing working directory to /users/parag
Tue Jan 17 12:05:39 2006: setuid( 1006 ) succeeded!
Tue Jan 17 12:05:39 2006: COMMAND = 99
Tue Jan 17 12:05:41 2006: START_SHADOW = 83
Tue Jan 17 12:05:41 2006: child fork succeeded 7891
Tue Jan 17 12:05:41 2006: Executing cmd->AUTO_JOB_PID=7891; export AUTO_JOB_PID; AUTOSYS=/Au
Tue Jan 17 12:05:41 2006: About to execl...
Tue Jan 17 12:05:41 2006: parent wait for user task 7891
Tue Jan 17 12:05:41 2006: Sending RUNNING Event...
Tue Jan 17 12:05:41 2006: about to send_event
Tue Jan 17 12:05:41 2006: Sending Event: 101 Status: 1 ...
Tue Jan 17 12:05:41 2006: Attempting to Connect to: SIRDORA
Tue Jan 17 12:05:42 2006: SENT Successfully !!!
Tue Jan 17 12:05:42 2006: AUTOSV not set
Tue Jan 17 12:05:42 2006: parent returned from wait, exit code 256 (0 1)
Tue Jan 17 12:05:42 2006: User task exit code = 1
Tue Jan 17 12:05:42 2006: Sending the Completion Event...
Tue Jan 17 12:05:42 2006: about to send_event
Tue Jan 17 12:05:42 2006: Sending Event: 101 Status: 5 ...
Tue Jan 17 12:05:42 2006: Attempting to Connect to: SIRDORA
Tue Jan 17 12:05:42 2006: SENT Successfully !!!
Tue Jan 17 12:05:42 2006: send_event() ret=0
Tue Jan 17 12:05:42 2006: auto_remote work complete, exiting
```

7.5.5 Calendars

This menu item is shown only for those jobs that use a “run_calendar” or “exclude_calendar”. You can view the name and the dates assigned to that each calendar by selecting the menu item. The calendar shown is “Read only” and no changes are permitted.

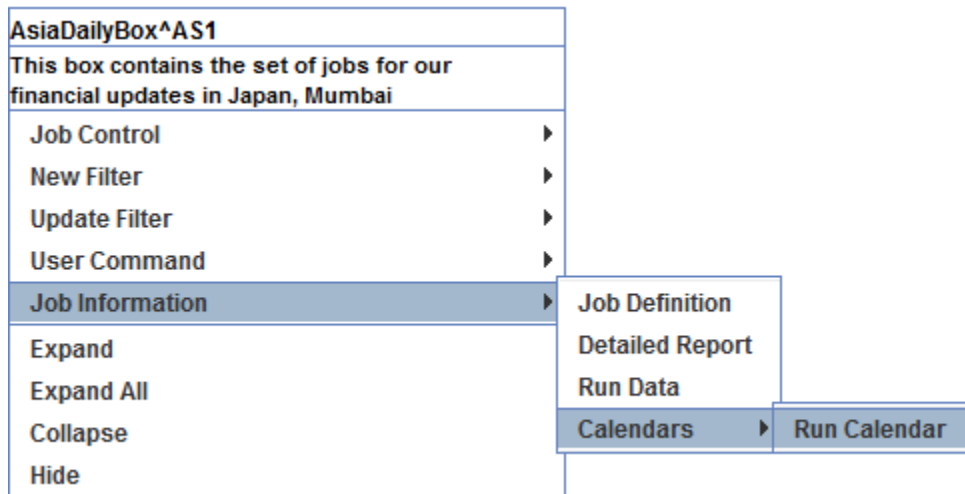

You can view one calendar year at a time by selecting the year from the pull-down. For each year, the dates set inside the calendar definition are shown in “green” color. The name of the calendar is shown in the title bar of the window.

Job Information

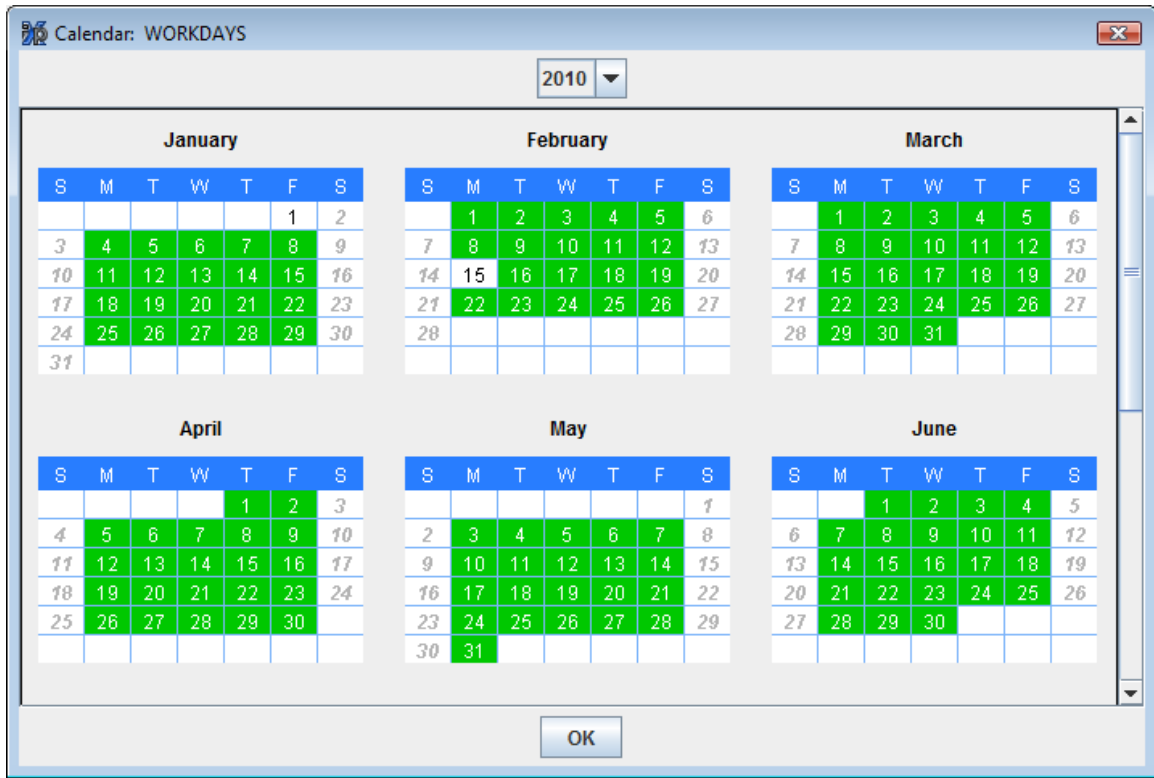

7.6 View Statistics

Server statistics provide a comprehensive report on the capacity, usage and performance of a CA Workload Automation AE instance. Non-admin users can see this option only if the privilege has been granted by the Administrator.

Select a CA Workload Automation AE Instance icon in the Tree View, and right mouse click to see the Instance Options menu.

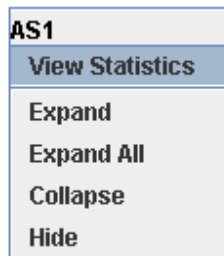

Select View Statistics to bring up the Server Statistics charts.

From top to bottom, the charts show the number of jobs started per minute, the number of jobs completed per minute, the events processed per minute, and the average event processing latency time in seconds, each plotted as a function of time. The gray area of each chart is set to contain eighty percent or more of the charted data.

View Statistics

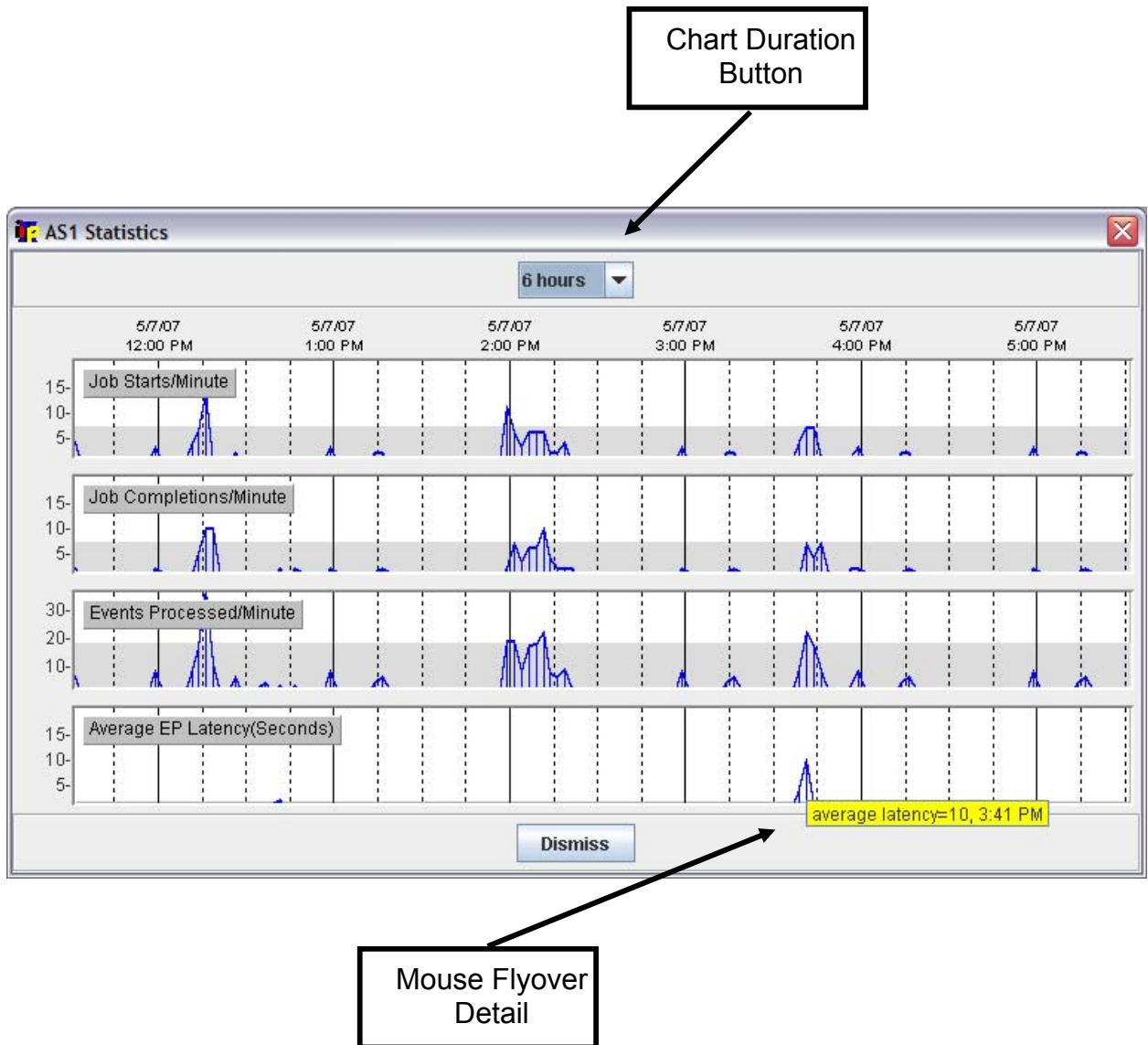

Use the chart duration button to select the time duration shown. Move the mouse over a chart to view the exact data value, and time, in the mouse flyover banner.

Using Server Statistics: These statistics provide guidance to the CA Workload Automation AE Administrator for capacity planning and fulfilling service level agreements. Ideally, the Event Processor latency should not be more than a few seconds and the number of jobs submitted should be as high as possible without affecting the latency. The gray area is set to show the average figures for every chart.

8 iXp CLIENT CLI

iXp provides a set of command line tools that enable users to execute the CA Workload Automation AE commands `sendevent`, `autorep`, and `jil` from their client machine without installing the CA Workload Automation AE software. These commands interface with the iXp Server and the actual execution of CA Workload Automation AE commands occurs on the iXp Server. The results of execution are passed back to the client. All the parameters supported by the actual CA Workload Automation AE commands can be passed to the iXp commands, including input files.

8.1 Installation

The iXp Client CLI is a self-contained set of files that need to be copied to each machine from where the commands will be executed. The total disk space required for these files is less than 3Mb.

Once the files have been copied, you need to set two environment variables and create a configuration file.

Environment Variables

`IXP_HOME`=<Directory where software resides>
`AUTOSERV`=<CA Workload Automation AE Instance name>

where,

`IXP_HOME` = The Base directory where the iXp Client CLI has been installed.
`AUTOSERV` = The 3-letter name of the CA Workload Automation AE instance for which the command is being executed. This variable can be set before each execution, if the commands are being used for multiple instances.

For example,

```
IXP_HOME=C:\ixphome  
AUTOSERV=ACE
```

Optional variables

```
IXP_SERVER_URL=< http://IXP_SERVER:PORT >  
IXP_SERVER_URL_2=< http://IXP_SERVER:PORT >
```

Installation

If these variables are defined, the Configuration File (see below) is ignored.

Configuration File

You must create a configuration file under the IXP_HOME/etc directory if the IXP_SERVER_URL variable is not defined in the environment. This file called *ixp.conf* contains a single line that provides the URL of the iXp Server to the Client CLI.

The following command will create this file.

```
echo "IXP_SERVER_URL=http://IXP_SERVER:PORT" >  
$IXP_HOME/etc/ixp.conf
```

 (UNIX/Linux)

```
echo IXP_SERVER_URL=http://IXP_SERVER:PORT >  
%IXP_HOME%\etc\ixp.conf
```

 (Windows)

where,

IXP_SERVER = The machine/IP address of the iXp Server

PORT = The HTTP port number of the iXp Server.

For example,

```
echo IXP_SERVER_URL=http://venus:8080 > C:\ixphome\etc\ixp.conf
```

If the *IXP_SERVER_URL* variable is defined in the environment, the configuration file is ignored. Once the configuration file has been created or the variable defined, you can run the client CLI.

If there is an alternate iXp server running for high availability, then an additional line can be added in the file to provide its connection information to the CLI.

```
echo "IXP_SERVER_URL_2=http://IXP_SERVER_2:PORT" >>  
$IXP_HOME/etc/ixp.conf
```

where,

IXP_SERVER_2 = Machine/IP address of the alternate iXp Server

PORT = The HTTP port of the alternate iXp Web Server

Similarly, the above can be set as an environment variable.

8.2 Commands

The iXp Client CLI provides six (6) commands in the IXP_HOME/bin directory. All except one (1) are counterparts to CA Workload Automation AE commands. Each command has the same syntax as its CA Workload Automation AE counterpart, and accepts the same input and parameters.

When you execute any command, the parameters and input file, along with your authentication information, are passed to the iXp Server defined in your configuration file. If you have been assigned the authorization to execute the command for all the parameters and input provided, the iXp Server will run the original CA Workload Automation AE counterpart, capture the results, and send them back to you.

8.2.1 ixautorep

The **ixautorep** command is the iXp counterpart of the CA Workload Automation AE “**autorep**” command. It accepts the same list of parameters that you can pass to the “autorep” command.

The following shows the syntax for the ixautorep command. Notice how it is actually the syntax of the CA Workload Automation AE “autorep” command.

```
C:\ixphome\bin>ixautorep
```

```
Usage: [-J Jobname] <-d | -s | -q | -t | -o [Override #] | -w>
        [-R run_num] [-L Print Level] [-N Retry] [-x]
        [-G GlobalName] [-M MachineName] [-D TNS_alias_name]
        IF OverRide# = 0, it will display OverRide Currently in
        Effect.
```

```
Error in command line for autorep.
JobName OR GlobalName OR MachineName is required.
```

When you run the ixautorep command with the “-J” option, it will provide the Summary, Detail, or Definition output, depending upon the parameters. Only those jobs for which you are authorized will be displayed.

Commands

```
C:\WINDOWS\system32\cmd.exe
C:\ixphone\bin>ixautorep -j %Pay%

Job Name                               Last Start           Last End             ST   Run  Pri/Kit
-----
Invent_ProcPrePay1                     05/08/2007 10:06:30 05/08/2007 10:08:30 SU 1649/1
Invent_ProcBonusPay1                   05/08/2007 10:10:42 05/08/2007 10:12:41 SU 1649/1
Invent_ProcPrePay2                     05/08/2007 10:06:30 05/08/2007 10:08:30 SU 1649/1
Invent_ProcBonusPay2                   05/08/2007 10:10:41 05/08/2007 10:12:40 SU 1649/1
Invent_ProcPrePay3                     05/08/2007 10:06:32 05/08/2007 10:08:32 SU 1649/1
Invent_ProcBonusPay3                   05/08/2007 10:10:52 05/08/2007 10:12:51 SU 1649/1
Invent_ProcPrePay4                     05/08/2007 10:06:33 05/08/2007 10:08:35 SU 1649/1
Invent_ProcBonusPay4                   05/08/2007 10:10:53 05/08/2007 10:12:53 SU 1649/1
Invent_ProcPrePay5                     05/08/2007 10:06:33 05/08/2007 10:08:34 SU 1649/1
Invent_ProcBonusPay5                   05/08/2007 10:10:52 05/08/2007 10:12:53 SU 1649/1
Invent_ProcPrePay6                     05/08/2007 10:06:34 05/08/2007 10:08:36 SU 1649/1
Invent_ProcBonusPay6                   05/08/2007 10:10:53 05/08/2007 10:12:54 SU 1649/1
Invent_ProcPrePay7                     05/08/2007 10:06:34 05/08/2007 10:08:37 SU 1649/1
Invent_ProcBonusPay7                   05/08/2007 10:10:53 05/08/2007 10:12:56 SU 1649/1
Invent_ProcPrePay8                     05/08/2007 10:06:34 05/08/2007 10:08:38 SU 1649/1
Invent_ProcBonusPay8                   05/08/2007 10:10:54 05/08/2007 10:12:57 SU 1649/1
Invent_ProcPrePay9                     05/08/2007 10:06:34 05/08/2007 10:08:39 SU 1649/1
Invent_ProcBonusPay9                   05/08/2007 10:10:57 05/08/2007 10:13:01 SU 1649/1
Invent_ProcPrePay10                    05/08/2007 10:06:35 05/08/2007 10:08:40 SU 1649/1
Invent_ProcBonusPay10                  05/08/2007 10:10:57 05/08/2007 10:13:01 SU 1649/1
Payroll_PRE_box1                       05/08/2007 10:00:06 05/08/2007 10:10:36 SU 1647/1
  Payroll_CalcPaysheet1                 05/08/2007 10:00:11 05/08/2007 10:01:51 SU 1647/1
  Payroll_CalcVacations1                05/08/2007 10:01:54 05/08/2007 10:03:35 SU 1647/1
  Payroll_CalcRetrol                     05/08/2007 10:03:38 05/08/2007 10:05:19 SU 1647/1
  Payroll_CalcPrePay1                   05/08/2007 10:05:23 05/08/2007 10:07:04 SU 1647/1
  Payroll_CalcSickTime1                 05/08/2007 10:07:08 05/08/2007 10:08:49 SU 1647/1
  Payroll_CalcBonusPay1                 05/08/2007 10:08:53 05/08/2007 10:10:34 SU 1647/1
Payroll_PRE_box2                       05/08/2007 10:00:06 05/08/2007 10:10:38 SU 1647/1
  Payroll_CalcPaysheet2                 05/08/2007 10:00:11 05/08/2007 10:01:52 SU 1647/1
  Payroll_CalcVacations2                05/08/2007 10:01:55 05/08/2007 10:03:37 SU 1647/1
  Payroll_CalcRetrol                     05/08/2007 10:03:40 05/08/2007 10:05:21 SU 1647/1
  Payroll_CalcPrePay2                   05/08/2007 10:05:25 05/08/2007 10:07:06 SU 1647/1
  Payroll_CalcSickTime2                 05/08/2007 10:07:10 05/08/2007 10:08:51 SU 1647/1
  Payroll_CalcBonusPay2                 05/08/2007 10:08:55 05/08/2007 10:10:36 SU 1647/1
Payroll_PRE_box3                       05/08/2007 10:00:06 05/08/2007 10:10:37 SU 1647/1
  Payroll_CalcPaysheet3                 05/08/2007 10:00:11 05/08/2007 10:01:52 SU 1647/1
  Payroll_CalcVacations3                05/08/2007 10:01:55 05/08/2007 10:03:36 SU 1647/1
  Payroll_CalcRetrol                     05/08/2007 10:03:40 05/08/2007 10:05:21 SU 1647/1
  Payroll_CalcPrePay3                   05/08/2007 10:05:24 05/08/2007 10:07:05 SU 1647/1
  Payroll_CalcSickTime3                 05/08/2007 10:07:08 05/08/2007 10:08:49 SU 1647/1
  Payroll_CalcBonusPay3                 05/08/2007 10:08:53 05/08/2007 10:10:35 SU 1647/1
Payroll_PRE_box4                       05/08/2007 10:00:06 05/08/2007 10:10:38 SU 1647/1
  Payroll_CalcPaysheet4                 05/08/2007 10:00:13 05/08/2007 10:01:53 SU 1647/1
  Payroll_CalcVacations4                05/08/2007 10:01:57 05/08/2007 10:03:38 SU 1647/1
  Payroll_CalcRetrol                     05/08/2007 10:03:41 05/08/2007 10:05:22 SU 1647/1
  Payroll_CalcPrePay4                   05/08/2007 10:05:25 05/08/2007 10:07:06 SU 1647/1
  Payroll_CalcSickTime4                 05/08/2007 10:07:10 05/08/2007 10:08:51 SU 1647/1
  Payroll_CalcBonusPay4                 05/08/2007 10:08:55 05/08/2007 10:10:36 SU 1647/1
Payroll_CalcPay_box                    05/08/2007 10:10:37 05/08/2007 10:14:13 SU 1647/1
  Payroll_CalcPay1                      05/08/2007 10:10:47 05/08/2007 10:12:24 SU 1647/1
  Payroll_CalcPay2                      05/08/2007 10:10:49 05/08/2007 10:12:25 SU 1647/1
  Payroll_CalcPay3                      05/08/2007 10:10:50 05/08/2007 10:12:25 SU 1647/1
  Payroll_CalcPay4                      05/08/2007 10:10:51 05/08/2007 10:12:27 SU 1647/1
  Payroll_PrintPaySlip1                 05/08/2007 10:12:28 05/08/2007 10:14:09 SU 1647/1
  Payroll_PrintPaySlip2                 05/08/2007 10:12:29 05/08/2007 10:14:10 SU 1647/1
  Payroll_PrintPaySlip3                 05/08/2007 10:12:29 05/08/2007 10:14:10 SU 1647/1
  Payroll_PrintPaySlip4                 05/08/2007 10:12:30 05/08/2007 10:14:11 SU 1647/1
```

When you run the ixautorep command with the “-M” or “-G” parameters, to view information about Virtual Machines or Global Variables respectively, all the machines and global variables will be displayed.

8.2.2 ixsendevent

The **ixsendevent** command is the iXp counterpart of the CA Workload Automation AE “**sendevent**” command.

The following shows the syntax of the ixsendevent command.

Commands

```
C:\ixphome\bin>ixsendevent
```

```
Usage: sendevent -E EVENT [-S AUTOSERV] [-A Alarm] [-J JobName]
        [-s Status] [-P Event Priority] [-M Max Send
Trys ]
        [-q Job Que Priority] [-G Global=Value] [-C
Comment]
        [-U (Un-SENDEVENT)] [-T Time of Event] [-K
Signal(s)]
```

```
Error in command line for sendevent.
Event [-E] is required.
```

When you run the `ixsendevent` command with the “-J” option, it will issue the `sendevent` to the job only if you are authorized to do so. Otherwise, the iXp Server will return a security exception.

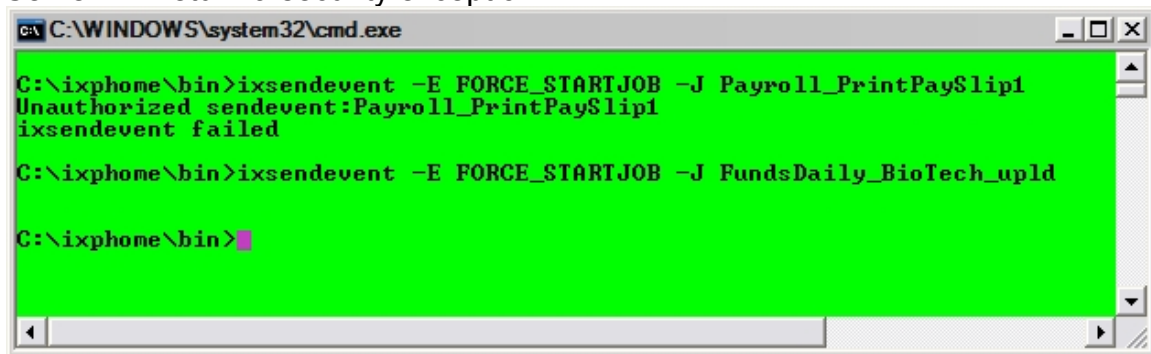

```
C:\WINDOWS\system32\cmd.exe
C:\ixphome\bin>ixsendevent -E FORCE_STARTJOB -J Payroll_PrintPaySlip1
Unauthorized sendevent:Payroll_PrintPaySlip1
ixsendevent failed
C:\ixphome\bin>ixsendevent -E FORCE_STARTJOB -J FundsDaily_BioTech_upld
C:\ixphome\bin>
```

You can pass any valid parameter supported by the CA Workload Automation AE “**sendevent**” command.

Note: `ixsendevent` does not allow “-E STOP_DEMON” events. These events have to be issued from your normal commands or interfaces.

8.2.3 ixjil

The **ixjil** command is the iXp counterpart for the CA Workload Automation AE “**jil**” command. This command enables you to create, update, or delete CA Workload Automation AE job and machine definitions using valid JIL statements.

You can run the `ixjil` command only in the batch mode. You have to either pass a filename or valid JIL statements as standard input.

In the screen below, you can see how the `ixjil` command is executed with JIL statements and filename as standard input.

Commands

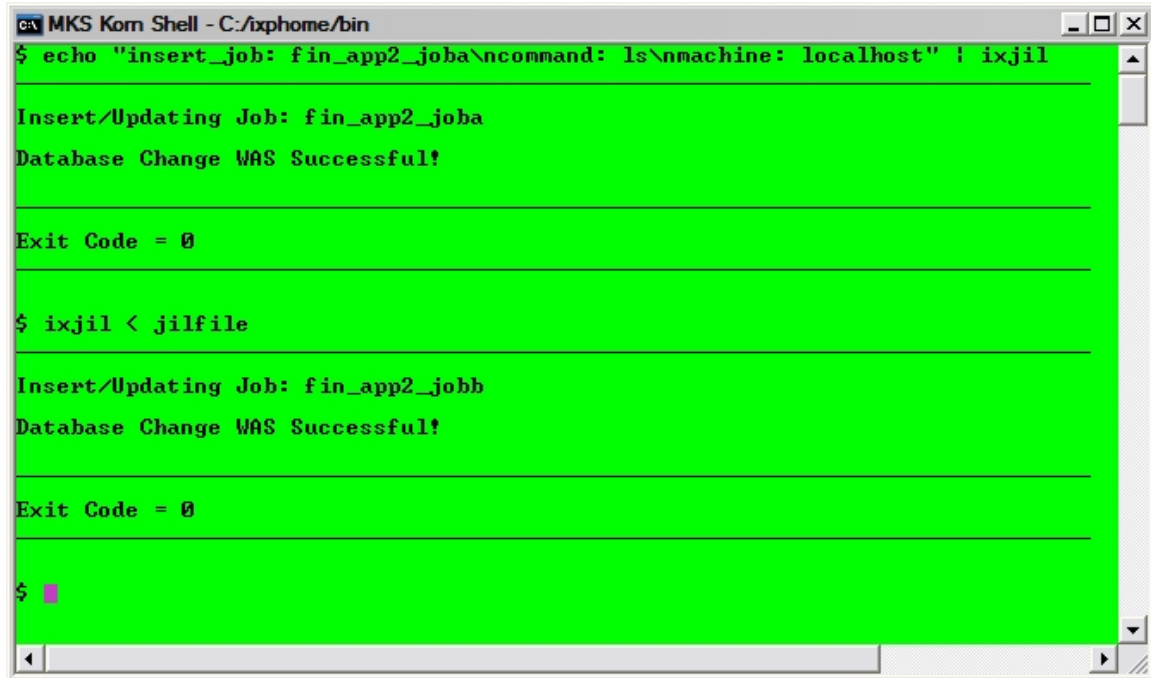

```
MKS Korn Shell - C:/ixphome/bin
$ echo "insert_job: fin_app2_job\ncommand: ls\nmachine: localhost" | ixjil

Insert/Updating Job: fin_app2_job
Database Change WAS Successful!

Exit Code = 0

$ ixjil < jilfile

Insert/Updating Job: fin_app2_job
Database Change WAS Successful!

Exit Code = 0

$
```

When you create, update, or delete job definitions, the name of the job has to match your authorizations. If the authorizations have been implemented with naming standards in place, the job name has to meet your naming standards as well.

In the example below, the user is authorized to create jobs with job names matching any of the following expressions.

```
fin_*_*
pay_*_*
```

Commands



```
MKS Korn Shell - C:/ixphome/bin
$ echo "insert_job: fin_app2_jobc\ncommand: ls\nmachine: localhost" | ixjil

Insert/Updating Job: fin_app2_jobc
Database Change WAS Successful!

Exit Code = 0

$ echo "insert_job: pay_app1_jobc\ncommand: ls\nmachine: localhost" | ixjil

Insert/Updating Job: pay_app1_jobc
Database Change WAS Successful!

Exit Code = 0

$ echo "insert_job: pay2_app1_jobc\ncommand: ls\nmachine: localhost" | ixjil
Unauthorized JIL request:job name=pay2_app1_jobc
ixjil failed
$
```

As shown above, the JIL insert statement for job `pay2_app1_jobc` failed as it did not meet the authorization.

Note: If the standard input to `ixjil` is a filename, the entire file should contain JIL statements that meet your authorizations. If it contains even one JIL statement that does not meet your authorization, the entire file will be rejected.

8.2.1 `ixautostatus`

The `ixautostatus` command is the iXp counterpart for the CA Workload Automation AE “`autostatus`” command. This command enables you to view the current status or value of a single CA Workload Automation AE job or global variable respectively.

The following shows the syntax of the `ixautostatus` command.

```
C:\ixphome\bin>ixautostatus
Usage: <-J JobName> OR <-G GlobalName> [-S AUTOSERV]
```

```
Error in command line for autostatus.
```

For example,

```
C:\ixphome\bin>ixautostatus -J EuropeDailyBox
SUCCESS
```

8.2.2 ixjob_depends

The **ixjob_depends** command is the iXp counterpart for the CA Workload Automation AE “**job_depends**” command. This command enables you to view the list of job dependencies, the current status of predecessor and successor jobs of a single job, or a forecast report of all jobs scheduled to run within a specific time frame and their successors.

The following shows the syntax of the ixjob_depends command.

```
C:\ixphome\bin>ixjob_depends
```

```
JobName is required.
```

```
Must specify Mode:
```

```
  c Current Condition Status
  d Dependencies Only (from Job Definition)
  t Time Dependencies (Forecasts)
```

```
Usage: job_depends < -c | -d | -t | -t -s | -t -e | -t -e -s >
<-J JobName>| -w
    [-F From Date/Time (MM/DD/YYYY HH:MM)]
    [-T To Date/Time]
    [-L Print Level]    [-D TNS_alias_name]
```

```
*** Error in command line for job_depends.***
```

The following shows sample output of ixjob_depends command.

```
C:\temp>ixjob_depends -j EuropeDailyBox -c
```

Job Name	Status	Date	Cond?	Start Cond?	Dependent Jobs?
EuropeDailyBox	SUCCESS	03/30/2010	10:30	Yes	Yes

```

  Condition: s<AsiaDailyBox> and v<OKTORUN> = YES
  Atomic Condition
  SUCCESS<AsiaDailyBox>
  VALUE<OKTORUN>
  Dependent Job Name
  FranceDailyBox
  Testbox_a
  Condition
  SUCCESS<EuropeDailyBox>
  SUCCESS<EuropeDailyBox>
C:\temp>
```

8.2.3 ixautocal_asc

The **ixautocal_asc** command enables you to view, create, modify, and delete standard CA Workload Automation AE calendars. The functionality is similar to the CA Workload Automation AE autocal_asc command.

The following example shows the command being executed with a filename that contains lines to add dates to a calendar

```
#>cat infile
TESTCAL
A
08/05/2011
09/05/2011
10/05/2011

#>ixautocal_asc < infile
Utility to Add/Delete or Print entries in Calendar.

Calendar Name: Add (A) or Delete (D) or Print (P) ?

Date (MM/DD/YYYY [HH:MM]):      ... Successful.
Date (MM/DD/YYYY [HH:MM]):      ... Successful.
Date (MM/DD/YYYY [HH:MM]):      ... Successful.
Date (MM/DD/YYYY [HH:MM]):
```

The following example shows the command being executed with standard input that prints out the dates in a calendar

```
#>echo "TESTCAL\nP" |ixautocal_asc
Utility to Add/Delete or Print entries in Calendar.

Calendar Name: Add (A) or Delete (D) or Print (P) ?

Days in the Calendar: TESTCAL
-----
08/05/2011 00:00
09/05/2011 00:00
10/05/2011 00:00
```

8.2.4 ixflags

The **ixflags** command is a command to view the current version of iXp Client.

```
$ ixflags
```

```
iXp-7.0
```

Note: This command is **not** a counterpart to the CA Workload Automation AE “**autoflags**” command.

9 INTERACTIVE FORECASTING

A key function of iXp is the ability to perform interactive forecasting and simulations. Forecast reports can be generated and simulations played back. All job run simulations are done by iXp and not actually run on CA Workload Automation AE. Simulation is based on historical averages and resolution of job dependencies as defined within CA Workload Automation AE. The results of a simulation can be viewed as steps-through-time and also can be saved in a report. Simulation also provides the ability to perform “what-if” scenarios that could help during decision-making

9.1 Go Offline

iXp has two modes, Online and Offline. Interactive forecasting can be performed only during Offline mode. When Offline mode is started all job dependencies and relevant attributes are loaded on the client, and during Offline mode job runs and current statuses are not loaded or shown. As a result, in Offline mode all jobs are initially marked as INACTIVE. Although the job data is highly compressed during Offline mode, it could impact the client machine performance because all that data is stored in memory on the client machine when a user decides to enter Offline mode. Therefore, iXp allows users to enter Offline mode with data for a single CA Workload Automation AE instance only. If iXp is monitoring more than one CA Workload Automation AE instance, the user is presented with a selection of CA Workload Automation AE instances when entering Offline mode.

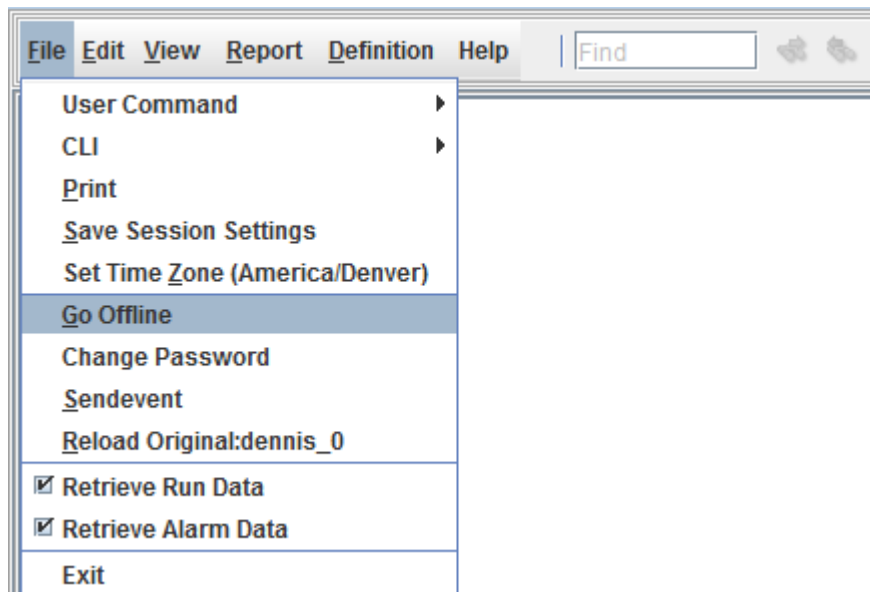

Select **File►Go Offline** to enter iXp Offline mode and enable Interactive Forecasting. First, a dialog box prompts the user to select the instance on which the forecasting is to be performed.

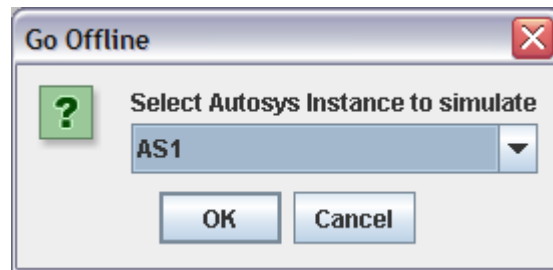

The offline mode will copy all the data of the selected instance to the local machine. All forecasting and simulation activities will be performed on that local snapshot.

Once in Offline mode, iXp presents jobs that match the current filter and also four new buttons that control interactive forecasting.



9.1.1 Rewind, Play, Pause

Clicking on the “**Play**” button  starts the forecast simulation sequences.

Simulations can be paused by clicking on the “**Pause**” button  and filters can be changed to view different jobs.

The “**Rewind**” button  is used to restart a simulation with the same parameters.

9.2 Forecast Configuration

The “**Customize**” button  launches the dialog for setting all the parameters for the simulation or forecasting. Once all the parameters have been defined, the user can also create or select the desired iXp filter. During the simulation, only jobs that match the filter will be shown in the views. For example, if a simulation is desired to view all jobs that would run on a particular set of machines during a specific date and time, a filter would have to be created or selected that would have the “Run Machine” attribute defined with the set of

Forecast Configuration

machines desired. Then, once the date and time values are set in the “Customize” panel, only the jobs that would run on those machines would be shown during the simulation. However, iXp would still perform a complete and comprehensive simulation of the selected CA Workload Automation AE instance, but only show jobs that match the selected filter.

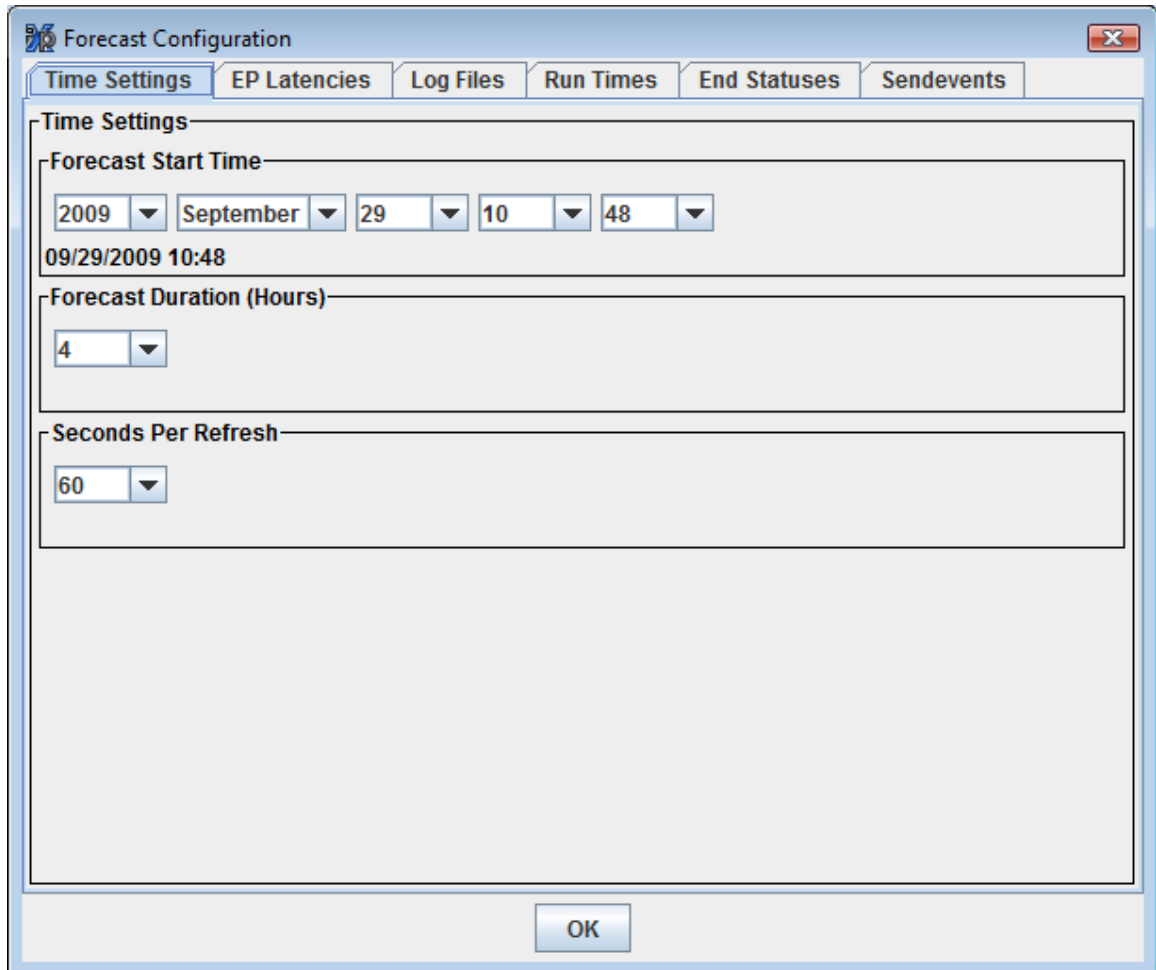

The screenshot shows a dialog box titled "Forecast Configuration" with a close button (X) in the top right corner. The dialog has six tabs: "Time Settings", "EP Latencies", "Log Files", "Run Times", "End Statuses", and "Sendevents". The "Time Settings" tab is selected and active. It contains three sections, each with a label and a dropdown menu:

- Forecast Start Time:** A dropdown menu showing "2009", "September", "29", "10", and "48". Below the dropdowns, the text "09/29/2009 10:48" is displayed.
- Forecast Duration (Hours):** A dropdown menu showing "4".
- Seconds Per Refresh:** A dropdown menu showing "60".

At the bottom center of the dialog box, there is an "OK" button.

There are six tabs that bring up different customizing options: Time Settings, EP Latencies, Log Files, Run Times, End Statuses and Sendevents. Use the options under each tab to customize the forecast as follows:

9.2.1 Time Settings

The Time Settings tab enables you to customize the forecast time window by selecting new values for the following attributes.

Time Settings Field	Description
Forecast Start Time	The year, month, day, hours and second for the forecast start time. Default value: current date and time.
Forecast Duration	The number of hours of forecast time. Default value: 4hrs.
Seconds Per Refresh	The number of simulated seconds per forecast window refresh (the “speed” of the forecast). Default value: 60 seconds.

Select **OK** to apply the changes and close the Forecast Configuration window.

9.2.2 EP Latencies

The screenshot shows the 'Forecast Configuration' dialog box with the 'EP Latencies' tab selected. The dialog contains eight settings, each with a dropdown menu. The values are as follows:

Setting	Value
Job Completion	50
VM Stat	50
Remote Agent Connect	2000
Set DB Status	50
X-Instance sendevent	50
Set DB Starting Status	50
Read DB Event	50
Set DB Running Status	50

An 'OK' button is located at the bottom center of the dialog.

Customize the forecast Event Processor Latencies, in milliseconds. These **EP Latencies** variables are described in the *Forecast Properties* Section of the *iXp Administration Guide*, corresponding as follows:

EP Latencies Field	Forecast Property Variable
Job Completion	setDoneStatusTimeMillis
VM Stat	vmstatTimeMillis
Remote Agent Connect	StartJobTimeMillis
Set DB Status	setStatusTimeMillis
X-Instance sendevent	xinstanceSendeventTimeMillis
Set DB Starting Status	setStartingTimeMillis
Read DB Event	readEventTimeMillis
Set DB Running Status	setRunningTimeMillis

9.2.3 Log Files

Interactive Forecasting can create **log files** for textual reports of the jobs forecast. These files are stored on the local machine where the simulation was performed.

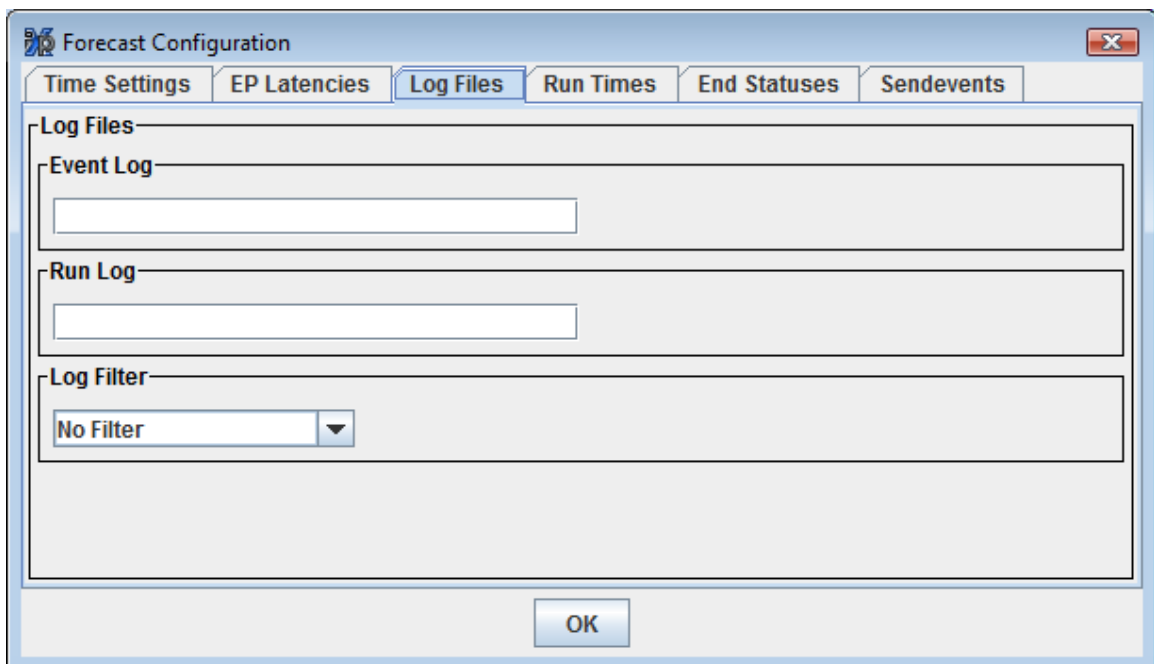

Forecast Configuration

Log Files Field	Description
Event Log	Desired location for the event log file.
Run Log	Desired location for the run log file.
Log Filter	Filter for data content of the log files. The Log Filter selections are described in the Job Filters Chapter of this document.

9.2.4 Run Times

The screenshot shows the 'Forecast Configuration' dialog box with the 'Run Times' tab selected. The dialog has several tabs: 'Time Settings', 'EP Latencies', 'Log Files', 'Run Times', 'End Statuses', and 'Sendevents'. The 'Run Times' section includes a 'Job Name' dropdown menu set to 'CACDaily_CAC_ftp2^DEV'. Below it is a 'Current Average Run Time' field showing '00h05m00s'. The 'Assigned Run Time' section has three input fields: '00h08m00s', '00h', and '08m', each with a dropdown arrow. The 'Run Time' section has an 'Add' button and a text field containing 'CACDaily_CAC_ftp2^DEV 00h08m00s'. The 'Simulated Run Times' section has a 'Delete' button and a list box containing 'CACDaily_CAC_ftp2^DEV 00h08m00s'. An 'OK' button is at the bottom center.

Customize run times for specific jobs. Assigning new run times for a job overrides the average run time values for the next forecasted run of the job.

Run Times Field	Description
Job Name	Name of job to which new run time is to be assigned.

Forecast Configuration

Current Average Run Time	The average run time currently used by the forecaster.
Assigned Run Time	The hours, minutes and seconds for a new run time may be built with the h, m, s picklists. The resulting run time is combined with the Job Name in the Run Time field.
Run Time	This field combines the Assigned Run Time with the Job Name fields. This may also be edited directly. Select Add to add the newly assigned time to the update list.
Simulated Run Times	This is a running list of all the run times one is preparing to add to the simulation. Run times on the list may be deleted by highlighting them and selecting Delete . (The same <i>selecting multiple jobs</i> method may be used as in other windows.) Upon selecting OK , the job names and times listed here will be assigned.

9.2.5 End Statuses

The screenshot shows the 'Forecast Configuration' dialog box with the 'End Statuses' tab selected. The 'Simulated FAILURE and TERMINATED' section contains a 'Job Name' dropdown set to 'FundsDaily_Chips_proc^DEV', an 'Assigned End Status' dropdown set to 'FAILURE', and an 'End Status' field with an 'Add' button and the text 'FundsDaily_Chips_proc^DEV FAILURE'. Below this is a 'Simulated End Statuses' list with a 'Delete' button and the same text. An 'OK' button is at the bottom.

Customize **End Status** for specific jobs. Assigning a new End Status for a job overrides the current End Status, in the job forecast processing logic, for the next forecasted runs of the job. If a job runs multiple times within your forecast window, each run will end in the status specified.

End Statuses Field	Description
Job Name	Job name to which a new End Status is to be assigned in the simulation.
Assigned End Status	Pick list for End Status currently to be assigned by the forecaster.
End Status	This field combines the Job Name and Assigned End Status fields, select Add to add the newly assigned value to the list.
Simulated End Statuses	This is a running list of all the End Statuses one is preparing to add to the simulation. End Statuses on the list may be deleted by highlighting them

and selecting **Delete**. (The same *selecting multiple jobs* method may be used as in other windows.) Upon selecting **OK**, the job names and End Statuses listed here will be assigned.

9.2.6 Sendevents

Add new **Future Sendevents** for the next iXp forecast run.

Sendevents Field	Description
Time	The time field sets the execution time of a simulated sendevent. In order to simulate a future Sendevent set the time fields to the desired future execution date and time.
Job Name	Job Name to which a new Sendevent is to be assigned.
Events	Event portion of the Sendevent JIL.
Future Sendevent	This field combines the Time, Job Name, and Events fields to define a Future Sendevent. Select Add to

	add this one to the Future Sendevents list. The JIL populated here is essentially the same as used in CA Workload Automation AE (except for the use of ^InstanceName in the iXp syntax).
Future Sendevents	This is a running list of all the Future Sendevents one is preparing to add to the simulation. Future Sendevents on the list may be deleted by highlighting them and selecting Delete . (The same jobs method may be used as in other windows.) Upon selecting OK , the job names and End Statuses listed here will be assigned.

9.2.7 Return iXp to Online Mode

Select **File►Go Online** to return iXp to online mode as shown below:

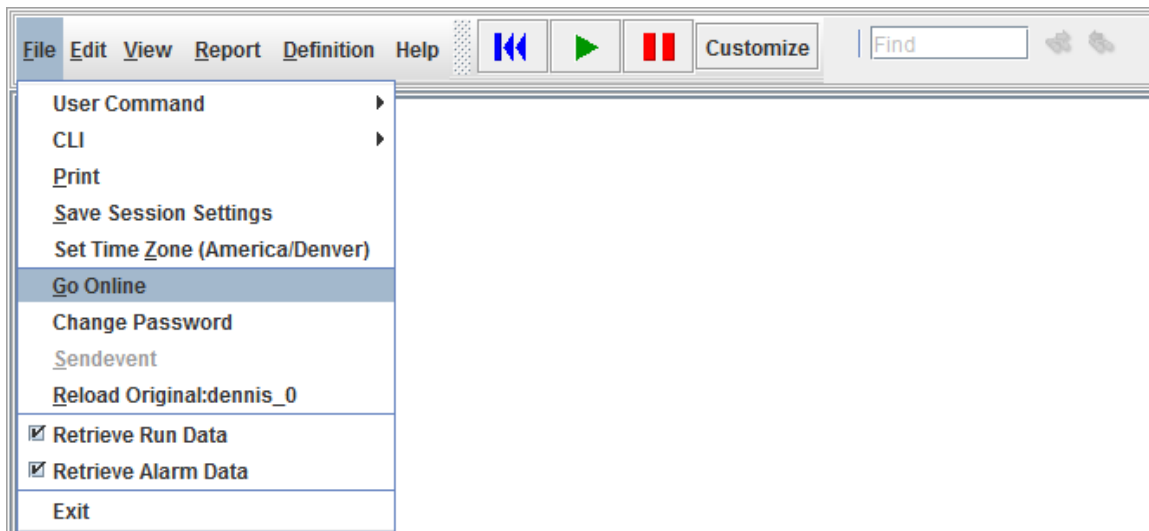

Upon return to online mode, Interactive Forecasting in iXp is disabled, and job runs and current statuses from the CA Workload Automation AE instances are again loaded and shown in iXp. Upon the next selection of **File►Go Offline** the Interactive Forecasting properties will be reset to the current job properties and defaults, all job dependencies and relevant attributes will be loaded on the client, and job runs and current statuses will not be loaded or shown.

Thus if one does not want to lose the information gained from a simulation in Offline Mode, the *log files* should be kept in saved file names.

9.3 View Forecast Run Data

Forecast jobs (jobs generated by the iXp Daemon rather than by CA Workload Automation AE) appear in the *Run Data* table (on the Job Tools Popup, Job Information menu) with job index number listed as **SIMULATED**, for example:

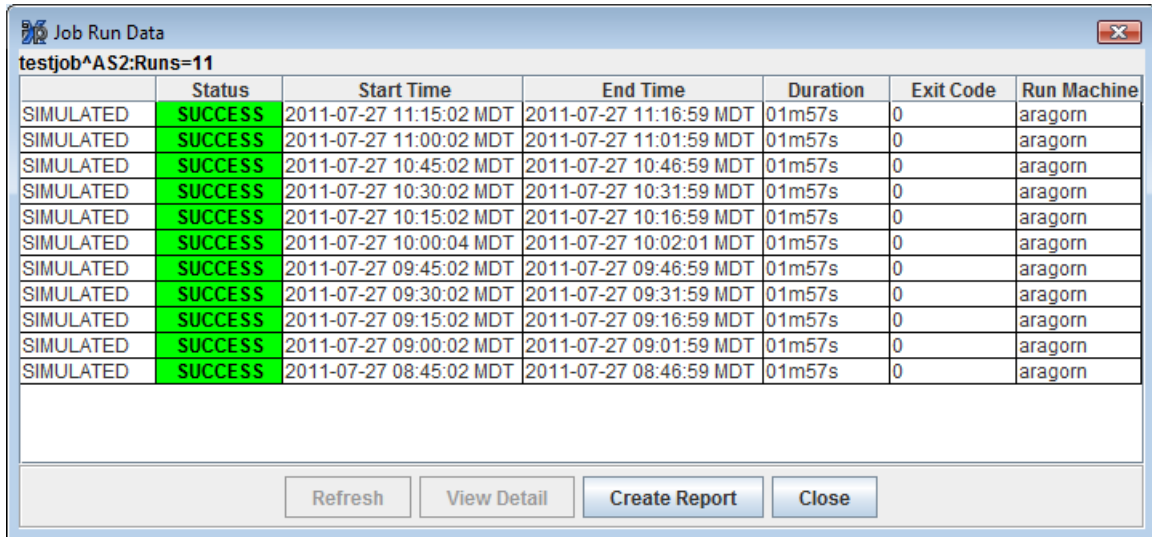

	Status	Start Time	End Time	Duration	Exit Code	Run Machine
SIMULATED	SUCCESS	2011-07-27 11:15:02 MDT	2011-07-27 11:16:59 MDT	01m57s	0	aragorn
SIMULATED	SUCCESS	2011-07-27 11:00:02 MDT	2011-07-27 11:01:59 MDT	01m57s	0	aragorn
SIMULATED	SUCCESS	2011-07-27 10:45:02 MDT	2011-07-27 10:46:59 MDT	01m57s	0	aragorn
SIMULATED	SUCCESS	2011-07-27 10:30:02 MDT	2011-07-27 10:31:59 MDT	01m57s	0	aragorn
SIMULATED	SUCCESS	2011-07-27 10:15:02 MDT	2011-07-27 10:16:59 MDT	01m57s	0	aragorn
SIMULATED	SUCCESS	2011-07-27 10:00:04 MDT	2011-07-27 10:02:01 MDT	01m57s	0	aragorn
SIMULATED	SUCCESS	2011-07-27 09:45:02 MDT	2011-07-27 09:46:59 MDT	01m57s	0	aragorn
SIMULATED	SUCCESS	2011-07-27 09:30:02 MDT	2011-07-27 09:31:59 MDT	01m57s	0	aragorn
SIMULATED	SUCCESS	2011-07-27 09:15:02 MDT	2011-07-27 09:16:59 MDT	01m57s	0	aragorn
SIMULATED	SUCCESS	2011-07-27 09:00:02 MDT	2011-07-27 09:01:59 MDT	01m57s	0	aragorn
SIMULATED	SUCCESS	2011-07-27 08:45:02 MDT	2011-07-27 08:46:59 MDT	01m57s	0	aragorn

testjob^AS2:Runs=11

Refresh View Detail Create Report Close

9.4 Errors and Warnings

The iXp client provides various indications to the user about problems that iXp may be experiencing. These indications are provided via the means of messages, warnings or certain behavior.

9.4.1 Warning for old data

The iXp Daemon is continuously reading data from the CA Workload Automation AE databases. The daemon is also incorporating the acquired data in the iXp cache, that is read by the iXp clients. The bottom-left corner of the application (e.g. web browser, appletviewer) from which the iXp client was launched shows the date and time stamp of the last cache update by the iXp Daemon. If the iXp Daemon is unable to read data from a CA Workload Automation AE instance, then it will not update the cache. To alert the user of such a condition, the iXp client will display a warning message at the lower-left corner stating that the particular CA Workload Automation AE instance has not been refreshed. Also, if the iXp Daemon does not have any other CA Workload Automation AE instance to read and if the cache has not been updated in five (5) minutes, the iXp client will get an error dialog message indicating the condition.



9.4.2 No Activity Warning

The iXp Administrator has the ability to set a time out for inactive GUIs. If there is no activity in the GUI for the given number of minutes, a notification dialog will appear:

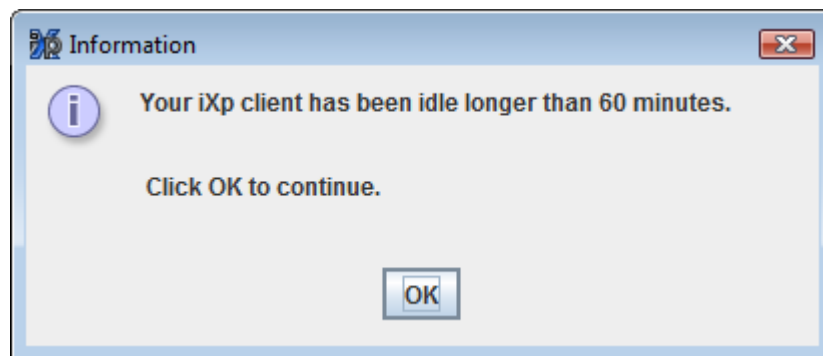

Clicking the OK button will return the iXp Client to normal refresh behavior.

9.4.3 iXp Client is “Out Of Memory”

The Java environment for the iXp client is configured with Java Runtime Parameters. These parameters define how much memory can be used by the Java Environment on the client. If the iXp client’s Java environment needs slightly more memory than that defined by the parameters, the Java environment will issue an “Out Of Memory” message and exit. This message is shown in the Java Console or the Java appletviewer command console if the iXp client was started from a web browser or the appletviewer respectively. If the iXp client was started through Java Web Start, the message will be shown in the Java console. There may be no visual indication on the iXp client indicating that it is “Out Of Memory”. Users may notice the iXp client going through data refreshes without updating the view or the data timestamp on the lower-left corner or may notice that the iXp client is not responding. To recover from this condition, the iXp client would have to be re-launched and the memory settings for the Java environment may have to be changed.

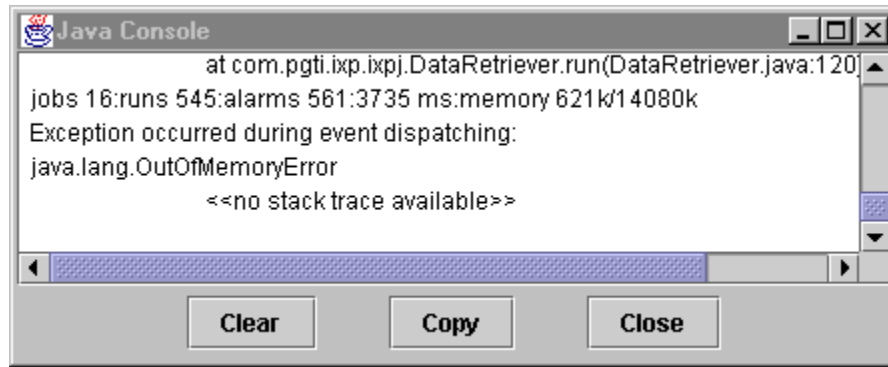

9.4.4 iXp Client gets “EOF” Exceptions

Users may notice “EOF” exception errors when performing certain operations that need the iXp client to contact the iXp server. Actions such as processing iXp reports, getting job definitions, issuing sendevents, responding to CA Workload Automation AE Alarms etc. may result in this exception. Typically, this happens due to a timeout parameter setting between the iXp client and the server. The default value for this parameter is 60 (sixty) seconds. If the iXp client has not received the results of its request within this time, it will throw this exception message to the user. The iXp client will not stop functioning due to this exception. Also, this exception does not indicate the result of the action requested. For example, the user clicks on a few alarms and tries to Acknowledge them. After the timeout interval, the iXp client throws the exception and continues with its refresh cycle. Meanwhile, the iXp Requestor finally updates the alarms in the CA Workload Automation AE database, but it cannot tell the user that requested the update about the completion of its work. However, the iXp client would receive the new data as a part of its refresh.

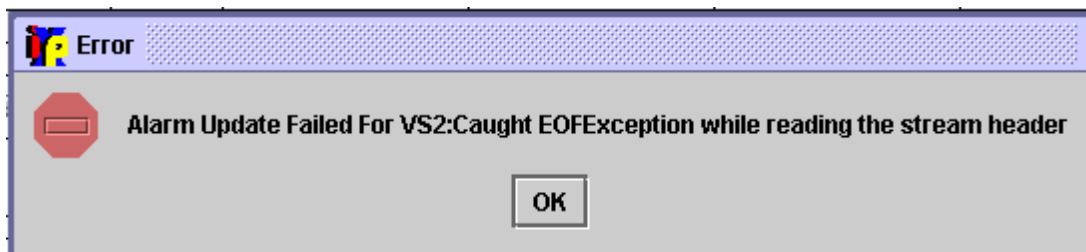

If the iXp Daemon has crashed, the iXp client will timeout for every refresh and throw the EOF exception message in the Java Console or the appletviewer command window. For users that launch iXp from a web browser, the Java Console is an extremely important window, as the majority of error messages would go in there. It is highly recommended to configure the Java environment so that this console is launched every time.

Errors and Warnings

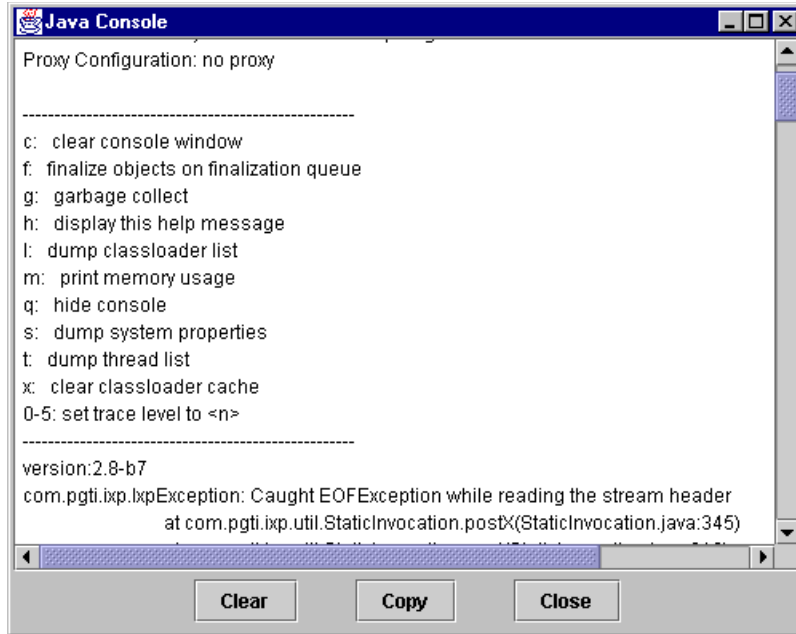

10 GLOSSARY

10.1 iXp Related Terms

Console View: Tabular listing of jobs and their vital data in the upper right portion of the iXp window.

Critical Path Filter: Focuses on a job and then follows predecessor and successor relationships (dependency relationships) from that job.

Exception Filter: A Job Attribute Filter that Displays only jobs that have failed or been terminated.

HTTPD: HyperText Transfer Protocol Daemon.

Instance Filter: A Job Attribute Filter that displays only the Site and its Instances.

Job Attribute Filters: Filters that use each CA Workload Automation AE job attribute to further define or limit the views in iXp.

Job Dependency Filters: Filters that limit the iXp views according to specified job dependencies.

Job Detail View: View in the upper center of the iXp window that shows details of the selected job.

Job Flow View: View in the lower right portion of the iXp window that shows the predecessor and successor job relationships for each job.

Level Zero Filter: A Job Attribute Filter that displays the Site, the Instances, and Level 0 boxes.

Recursive Critical Path Filter: Applies an ancestor-progeny filter that passes all the parents and children of the selected job, all their parents and children, and so forth through the job stream. Then a Critical Path filter is applied to each of those jobs.

Running Filter: A Job Attribute Filter that displays only running jobs.

Server Invocation: A call from a client (web browser) to the server, which in turn makes a call to refresh or request data from a CA Workload Automation AE Instance.

SHTTP: Secure HyperText Transfer Protocol

Site: A group of one or more CA Workload Automation AE instances.

Site Filter: A Job Attribute Filter that displays only the Site icon.

Transitive Closure Filter: Follows all Box and dependency relationships in both directions, throughout the CA Workload Automation AE Job structure. First a Recursive Critical Path filter is applied to the selected job, and then a Recursive Critical Path filter is applied to the resulting jobs, and so forth through the job stream.

Tree View: View on the left of the iXp window that depicts the hierarchical box structure of the jobs.

10.2 CA Workload Automation AE Terms

See also [CA Workload Automation AE User Guide](#)

Alarm: Alarms are special events that notify operations personnel of situations requiring attention.

Box Job: A CA Workload Automation AE job that spawns other jobs that are “contained” in the Box Job.

Global Variable: Set by the sendevent SET_GLOBAL commands, Global Variables are used to create dependency relationships.

JIL: Job Information Language. Refer to the [CA Workload Automation AE User Guide](#).

Job: A job is the basic building block upon which an operations cycle is built. An CA Workload Automation AE job is any single command or executable, UNIX shell script, or NT batch file. Each CA Workload Automation AE job definition contains qualifying attributes, including conditions for when and where a job should be run. Command Jobs execute commands, Box Jobs are containers, which hold other jobs, and File Watcher Jobs watch for the arrival of a specified file.

Job Name: The job name is used to identify the job to CA Workload Automation AE, and must be unique within CA Workload Automation AE. It can be from 1 to 30 alphanumeric characters, and is terminated with white space. Embedded blanks and tabs are illegal.

JOID: Job ID (see [CA Workload Automation AE Reference Guide](#)).

sendevent: A CA Workload Automation AE command to activate the Event Processor.

10.3 Symbols in this Guide

Symbol or type style	Represents	Example
Bold	A new term.	The console is the upper right window in iXp.
Alternate color	Hyperlinks to other sections, or to the internet.	See http://java.sun.com for further information.
<i>Italic</i>	Words that are emphasized. Blue italic for hyperlinks. <u><i>Underlined Italic</i></u> for titles of other documents.	Dismiss the window <i>after</i> finalizing your changes. <u><i>CA Workload Automation AE User Guide</i></u>
Monospace	Syntax variables. Directories, file names, command names, computer code. Computer screen text, system responses, command line commands.	<code>COPY filename</code> <code>&HIGHLVL . SRCLIB</code> Copy file? Y/N
Monospace bold	What a user types.	...enter RUN APP . EXE in the Application field.
<>	The name of a key on the Keyboard.	Press <Enter>.
▶	Choosing a command from a menu.	Edit▶ Preferences.

10.4 Related Documents

CA Workload Automation AE User Guide

CA Workload Automation AE Windows Implementation Guide

CA Workload Automation AE UNIX Implementation Guide

CA Workload Automation AE Reference Guide

iXp Release Notes

iXp Administration Guide