

XMENU

XMENU in Minutes **A Guide to Using XMENU/DIALOG**

September 1991



Computer Associates™

030510510801

This documentation and related computer software program (hereinafter referred to as the "Documentation") is for the end user's informational purposes only and is subject to change or withdrawal by Computer Associates International, Inc. ("CA") at any time.

THIS DOCUMENTATION MAY NOT BE COPIED, TRANSFERRED, REPRODUCED, DISCLOSED OR DUPLICATED, IN WHOLE OR IN PART, WITHOUT THE PRIOR WRITTEN CONSENT OF CA. THIS DOCUMENTATION IS PROPRIETARY INFORMATION OF CA AND PROTECTED BY THE COPYRIGHT LAWS OF THE UNITED STATES AND INTERNATIONAL TREATIES.

TO THE EXTENT PERMITTED BY APPLICABLE LAW, CA PROVIDES THIS DOCUMENTATION "AS IS" WITHOUT WARRANTY OF ANY KIND, INCLUDING WITHOUT LIMITATION, ANY IMPLIED WARRANTIES OF MERCHANTABILITY, FITNESS FOR A PARTICULAR PURPOSE OR NONINFRINGEMENT. IN NO EVENT WILL CA BE LIABLE TO THE END USER OR ANY THIRD PARTY FOR ANY LOSS OR DAMAGE, DIRECT OR INDIRECT, FROM THE USE OF THIS DOCUMENTATION, INCLUDING WITHOUT LIMITATION, LOST PROFITS, BUSINESS INTERRUPTION, GOODWILL OR LOST DATA, EVEN IF CA IS EXPRESSLY ADVISED OF SUCH LOSS OR DAMAGE.

THE USE OF ANY PRODUCT REFERENCED IN THIS DOCUMENTATION AND THIS DOCUMENTATION IS GOVERNED BY THE END USER'S APPLICABLE LICENSE AGREEMENT.

The manufacturer of this documentation is Computer Associates International, Inc.

Provided with "Restricted Rights" as set forth in 48 C.F.R. Section 12.212, 48 C.F.R. Sections 52.227-19(c)(1) and (2) or DFARS Section 252.227.7013(c)(1)(ii) or applicable successor provisions.

© 2001 Computer Associates International, Inc.,

All rights reserved.

All trademarks, trade names, service marks, or logos referenced herein belong to their respective companies.

Preface

Shown below is an example of a panel that was created using XMENU/DIALOG — in fact, it's one of the panels that you are going to create during this tutorial.

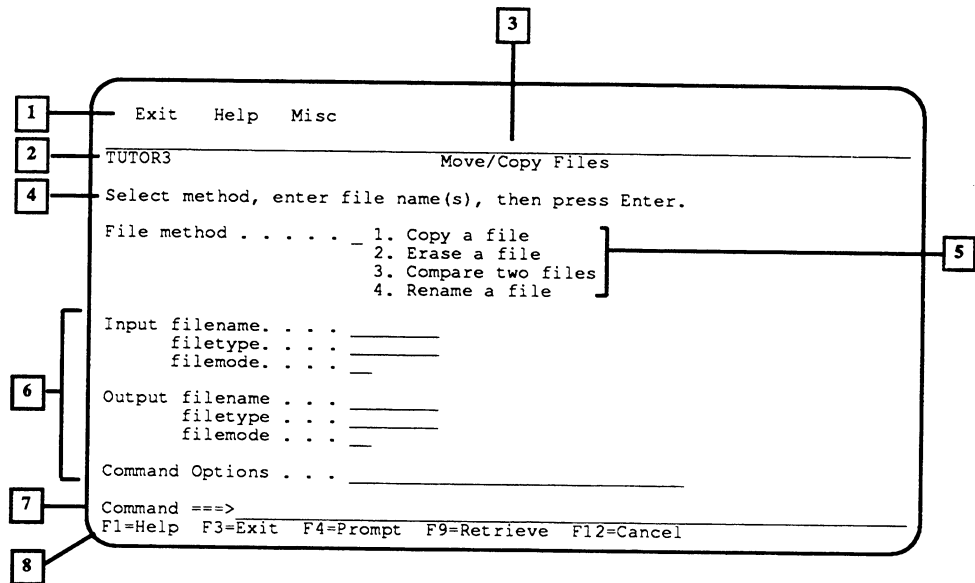

What are these different parts of the panel?

- Item **1** is the action bar
- Item **2** is the panel I.D.
- Item **3** is the panel title
- Item **4** is the informational area of the panel
- Item **5** is a selection list
- Item **6** is an example of several entry fields
- Item **7** is the command line and error message area
- Item **8** are the function keys

You'll learn about each of these areas in this tutorial when you create your application's panels.

We have tried to keep this tutorial as simple as possible. Although there are many capabilities for performing specialized tasks, this tutorial introduces only a few of the most commonly used ones.

When you feel that you have mastered the basic *XMENU/DIALOG* concepts presented here and are ready to use the more advanced features, go to the *XMENU/DIALOG User's Guide* for additional information.

Contents

Chapter 1. Introducing XMENU/DIALOG	1
Chapter 2. Setting the scene	3
Chapter 3. Creating panels using XMENU/DIALOG	7
Chapter 4. Creating your top panel — TUTOR0	9
Creating an action bar	11
Creating the panel I.D.	12
Creating the panel title	13
Creating an informational area	14
Creating a selection list	15
Creating the command line and error message line	16
Creating a function key area	17
Saving your XMENU panel	18
Saving your XMENUCUA control file	20
Preparing for a new panel	21
Chapter 5. Creating a panel with multiple entry fields — TUTOR1	23
Creating an entry field	24
Other entries for TUTOR1	25
Changing the order of panel elements	25
Preparing for a new panel	26
Chapter 6. Creating a panel with entry fields and a selection list — TUTOR3	27
Creating a selection list with a field prompt	28
Creating entry fields with variations on spacing	29
Other entries for TUTOR3	30
Preparing for a new panel	30
Chapter 7. Creating a panel with two selection lists — TUTOR5	31
Creating two selection lists	32
Other entries for TUTOR5	33
Preparing for a new panel	33
Chapter 8. Creating a pop-up window — TUTOR8	35
XMENU entries for TUTOR8	36
Disabling the command line and error message line	37
Viewing the pop-up window	38
Chapter 9. Creating your application dialog using XTREE	41
Chapter 10. Defining the dialog for your main panel — TUTOR0	43
Specifying panel information	43
Specifying panel parameters	45
Defining action bar commands	46
Defining function key commands	47
Defining selection list commands	48

Defining error messages	49
Chapter 11. Defining the dialog for TUTOR1	51
Specifying panel information	52
Defining function key commands	53
Other XTREE entries for TUTOR1	55
Chapter 12. Defining the dialog for TUTOR3	57
XTREE entries for TUTOR3	58
Chapter 13. Defining the dialog for TUTOR5	59
Specifying the selection list	60
Other XTREE entries for TUTOR5	61
Chapter 14. Defining the dialog for TUTOR8	63
Defining panel parameters	64
Specifying MENUEXEC subcommands	65
Other XTREE entries for TUTOR8	66
Chapter 15. Defining global function key commands	67
Chapter 16. Defining global commands	69
Chapter 17. Saving and testing your application dialog	71
Saving the application dialog	71
Testing your application dialog	73
Chapter 18. Testing and running your application dialog	75
Appendix. Your completed MENUTREE file	77
Glossary	81
Index	85

Chapter 1. Introducing XMENU/DIALOG

XMENU/DIALOG is a full-function panel generator and dialog manager that allows you to interactively design panels and define the dialog that control user movement between those panels. XMENU/DIALOG creates the panels according to IBM's System Applications Architecture (SAA) Common User Access (CUA) standards and automatically generates the REXX code for managing the dialogs you define.

XMENU/DIALOG has two primary components:

- **XMENUCUA**, which you use to create CUA-compliant panels
- **XTREE**, which allows you to control the order and display of panels that you create with XMENUCUA

You'll use several XMENU/DIALOG features in the exercise that follows. But first, let's set the scene for the application that you'll be developing.

Chapter 2. Setting the scene

If you are familiar with creating application dialogs, you know that it can be a tedious process. You have to create action bars, informational areas, selection lists, entry areas, command line and error message processing, function key logic, and pop-up window design and behavior.

In this tutorial, you'll be creating all of the above. But instead of duplicating many of these processes for every panel in the application, we've provided you with a partially completed application. You'll be completing those parts of the application that are missing so that when you are finished, you'll have a running application.

We've provided you with three files on the product distribution tape:

- *DLG_MSTR MENUTREE* contains the completed tutorial application control file
- *DLG_MSTR EXEC* is the final executable REXX EXEC
- *DLGTUTOR MENUTREE* contains the partially completed tutorial application

The following diagram shows the panels that make up the entire application:

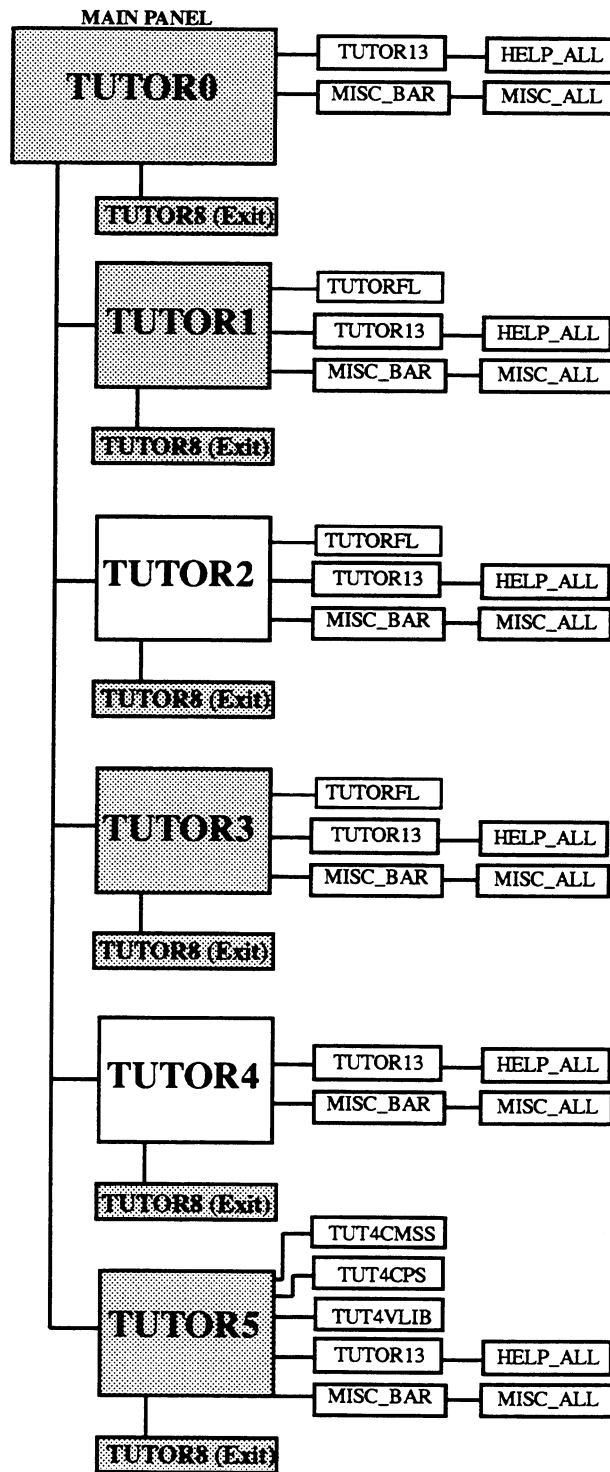

The shaded boxes are the panels that you are going to create using this tutorial; the unshaded boxes are the panels that have already been created for you. As

TUTOR0 is the main panel. From TUTOR0, you have five choices — TUTOR1 through TUTOR5. From each of those panels, you can choose any of the three selections from the action bar:

- Exit (TUTOR8 panel), which allows you to exit from the application
- Help (TUTOR13 panel), which is a pull-down menu selection list
- Misc (MISC_BAR panel), which displays a generalized pull-down menu

Also, you can choose other specified functions:

- TUTORFL, which displays a pop-up window with a list of files for you to choose from
- TUT4CMSS, which displays a panel allowing you to view and change your CMS settings
- TUT4CPS, which displays a panel allowing you to view and change your CP TERM settings
- TUT4VLIB, which displays a panel showing all accessed MACLIBs, TXTLIBs, and LOADLIBs, allowing you to denote which LIBs should be GLOBALed

We've provided the completed application in case you want to see what it does before you begin the tutorial. At the CMS command line, type *DLG_MSTR*. As you look through the application, you'll see the different panels that comprise the entire application. Explore a bit to get a feel for XMENU/DIALOG.

When you have finished, exit the completed application and continue with "Creating panels using XMENU/DIALOG" on page 5 to begin learning XMENU/DIALOG.

Chapter 3. Creating panels using XMENU/DIALOG

Using this tutorial, you're going to create an application that has a total of 15 panels. However, many of these panels are so similar to others that it would be time-consuming for you to create all 15. So, we've already created ten of the panels for you. Your job is to complete the other five:

- TUTOR0** your application's main panel
- TUTOR1** a panel with multiple entry fields
- TUTOR3** a panel that has both entry fields and a selection list
- TUTOR5** a panel with two selection lists
- TUTOR8** a pop-up window

To create the menus, you will be invoking a component of XMENU/DIALOG called XMENUCUA.

The following sections show you how to create these menus and pop-up windows. After you have finished, we'll tell you where to find the files for the other ten menus and how to establish a dialog with all 15 menus.

Chapter 4. Creating your top panel — TUTOR0

You are now ready to start developing your *XMENU/DIALOG* application. To start *XMENUCUA*, type *XMENUCUA* at the CMS command line, press Enter, and here's what you will see:

```
-----  
          XMENU SAA/CUA Guide Mode Facility  
  
x  x m  m eeee n  n u  u ccccc u  u  aa  
x x mm mm e  nn n u  u c    u  u  a  a  
x  m m m eee n n n u  u c    u  u  aaaaa  
x x m  m e  n nn u  u c    u  u  a  a  
x  x m  m eeee n  n uuuu ccccc uuuu a  a  
  
          Version 1, Release 1, Modification 1  
          Copyright 1990, 1991 - Relay Technology  
          All Rights Reserved  
  
Enter F12=Cancel  
-----
```

Press Enter to continue.

If you want to exit while using *XMENUCUA*

Select the File action bar item and select Save as.... Name the control file and panel as stated in the chapter that you are working on. Save the panel and control file, and use F3 to exit. When you come back and want to reenter *XMENUCUA*, select the File action bar item, select Open to reopen the unfinished control file, and continue building the panel.

The first panel that you're going to create is TUTOR0, your application's main panel. The following shows what the finished panel will look like:

```

Exit Help Misc
-----
TUTOR0                               XMENU/DIALOG Tutorial
Choose one of the following. Then press Enter.

- 1. Browse a file
  2. Edit a file
  3. Copy, Erase, Compare, Rename file(s)
  4. Display a list of CMS files
  5. Miscellaneous CP/CMS services

Command ==>
F1=Help F3=Exit F9=Retrieve F10=Actions F12=Cancel

```

Your terminal screen should now have the main XMENUCUA panel showing:

```

File Edit View Options Help
-----
XMECUA0                               XMENU CUA Prompter
Select one of the following. Then press Enter.

- 1. Create an Action Bar
  2. Create the Panel I.D.
  3. Create the Panel Title
  4. Create an Informational Area
  5. Create a Selection Field or List
  *. Create an Action List
  7. Create an Entry Field or Protected Text
  8. Create a Command Area and/or Error Message Line
  9. Create a Function Key Area

 10. Change the order of Panel Elements
 11. Save the menu in XMENU menu format
 *2. Save the menu in DIALOG Tag Language (DTL) format

Command ==>
F1=Help F3=Exit F9=Retrieve F10=Actions F12=Cancel F21=Command

```

To create TUTOR0, you'll need to perform nine steps:

- Create an Action Bar
- Create the Panel I.D.
- Create the Panel Title
- Create an Informational Area
- Create a Selection List
- Create a Command Area and Error Message Line
- Create a Function Key Area
- Save the panel in XMENU menu format
- Save the XMENUCUA control file using the FILE action bar item

Creating an action bar

Notational Conventions ...

Throughout this tutorial, you'll see numbers like **1**. These numbers reference the selection number in the XMENUCUA main panel. Also, the information that you will need to enter in each panel is in bold letters and any new steps that you will perform are highlighted in each section.

Select Create an Action Bar **1** and the following is displayed:

```
File Edit View Options Help
-----
XMECUA1                      XMENU CUA Prompter - Create Action Bar
Enter Action Bar items below. Then press Enter.
Action Bar Item 1. . . . Exit                1-20 characters
Action Bar Item 2. . . . Help
Action Bar Item 3. . . . Misc
Action Bar Item 4. . . .
Action Bar Item 5. . . .
Action Bar Item 6. . . .
Action Bar Item 7. . . .
Action Bar Item 8. . . .
Action Bar Item 9. . . .
Action Bar Item 10. . . .
Action Bar Item 11. . . .
Action Bar Item 12. . . .
Action Bar Item 13. . . .
Action Bar Item 14. . . .

Command ==>
F1=Help F3=Exit F9=Retrieve F10=Actions F12=Cancel F21=Command
```

You need to create three action bar items for TUTOR0 — Exit, Help, and Misc. Type each on an individual line as shown above and press Enter. Press F12 to return to the XMENUCUA main panel.

Creating the panel I.D.

Select Create Panel I.D. **2** and the following is displayed:

```
File Edit View Options Help
-----
XMECUA2                               XMENU CUA Prompter - Create Panel I.D.
Enter the name of this Panel below.  Then press Enter.
Panel I.D. . . . . . TUTOR0          1-10 characters

Command ==>
F1=Help F3=Exit F9=Retrieve F10=Actions F12=Cancel F21=Command
```

Type *TUTOR0* in the Panel I.D. field and press Enter. Press F12 to return to the XMENUCUA main panel.

Creating the panel title

Select Create the Panel Title **3** and the following is displayed:

```
File Edit View Options Help
-----
XMECUA3                               XMENU CUA Prompter - Create Panel Title
Enter the title for this Panel.  Then press Enter.
Panel Title. . XMENU/DIALOG Tutorial

Command ==>
F1=Help F3=Exit F9=Retrieve F10=Actions F12=Cancel F21=Command
```

Type *XMENU/DIALOG Tutorial* and press Enter. Press F12 to return to the XMEUCUA main panel.

Creating an informational area

Select Create an Informational Area **4** and the following is displayed:

```
File Edit View Options Help
-----
XMECUA4                               XMENU CUA Prompter - Create Information Area
Enter the type of area you are generating, its placement, and its text.
Area Name. . : T1
Space after. . Y (Y=space after this area, N=no space after this area)
Text . . . . .
Choose one of the following. Then press Enter.

Command ==>
F1=Help F3=Exit F9=Retrieve F10=Actions F12=Cancel F21=Command
```

Type *Choose one of the following. Then press Enter* in the Text field. Press Enter. Then press F12 to return to the XMENUCUA main panel.

Creating a selection list

Select Create a Selection Field or List **5** and the following is displayed:

```
File Edit View Options Help
-----
XMECUA5          XMENU CUA Prompter - Create a Selection Field or List

Enter the type of list you are generating, group heading, and selections

List Name. . . : L1
List Type. . . : S (S=Single Selection, M=Multiple Selection)
Space after. . : Y (Y=space after this area, N=no space after this area)
Heading. . . .
Field Prompt .

List items . . 1. Browse a file           Item 1 of 50
                2. Edit a file           1-40 characters
                3. Copy, Erase, Compare, Rename file(s)
                4. Display a list of CMS files
                5. Miscellaneous CP/CMS Services

Command ==>
F1=Help F3=Exit F4=Up F5=Down F7=Bkwd F8=Fwd F10=Actions F12=Cancel
```

Enter the information as shown above next to List items and press Enter. Then press F12 to return to the XMENUCUA main panel.

Creating the command line and error message line

Select Create a Command Area and/or Error Message Line **8** and the following is displayed:

```
File Edit View Options Help
-----
XMECUA8      XMENU CUA Prompter - Create Command and Error Message Area
Enter the number of lines you want for the Command and/or Error Message
Areas. Then press Enter.
Command Area Size. . . . 1 (0-2)
Error Message Line . . . Y (Y=reserve a line for error message, N=no line)

Command ==>
F1=Help F3=Exit F9=Retrieve F10=Actions F12=Cancel F21=Command
```

The default for the Command Area Size is 0, so you need to change this number to 1 so that a command area will appear. Also, keep the default for the error message line as Y to reserve a line for error messages. Press Enter. Then, press F12 to return to the XMENUCUA main panel.

Creating a function key area

Select Create a Function Key Area **9** and the following is displayed:

```
File Edit View Options Help
-----
XMECUA9                               XMENU CUA Prompter - Create Function Key Area
Enter text for Function Keys below.  Leave undefined Function Keys blank.

F1 = Help                               F13=
F2 =                                       F14=
F3 = Exit                               F15=
F4 =                                       F16=
F5 =                                       F17=
F6 =                                       F18=
F7 =                                       F19=
F8 =                                       F20=
F9 = Retrieve                            F21=
F10= Actions                            F22=
F11=                                       F23=
F12= Cancel                             F24=

Command ==>>
F1=Help F3=Exit F9=Retrieve F10=Actions F12=Cancel F21=Command
```

Enter the information as shown above and press Enter. Then, press F12 to return to the main XMENUCUA panel.

Saving your XMENU panel

You've finished creating your application's main panel. To see how it looks on the screen, select Save the menu in XMENU menu format **11** and the following is displayed:

```
File Edit View Options Help
-----
XMECUAXM          XMENU CUA Prompter - Create XMENU Menu

Enter the name of the menu, and its size. Then press Enter.
Use MAX for a size if you want the menu to take up the whole current
screen size. Use MIN if you want the menu to be as small as possible,
for example, to be used as a pop-up menu.

Menu name. . . . . TUTOR0 1-8 characters
Lines in the menu. . . . 24 A number, MAX or MIN
Columns in the menu. . . 80 A number
Save the XMENU menu. . . Y Y for yes, N for no
Remain in XMEDIT . . . . N Y for yes, N for no

Command ==>
F1=Help F3=Exit F9=Retrieve F10=Actions F12=Cancel F21=Command
```

Type *TUTOR0* next to the Menu name field.

Note: Be sure to type the numeral **0** and **not** the letter **O** in the menu name for *TUTOR0* so that no errors will occur later when XMENU/DIALOG is trying to locate the correct menu.

The default for the number of lines is 24 and the default for the number of columns is 80. Press Enter and the panel that you created appears:

```
Exit Help Misc
-----
TUTOR0                                XMENU/DIALOG Tutorial
Choose one of the following. Then press Enter.

1. Browse a file
2. Edit a file
3. Copy, Erase, Compare, Rename file(s)
4. Display a list of CMS files
5. Miscellaneous CP/CMS services

.

Command ==>
F1=Help F3=Exit F9=Retrieve F10=Actions F12=Cancel
```

Press Enter again to return to the Create XMENU Menu panel.

Saving your XMENUCUA control file

When you save in XMENU menu format, the panel is saved in an internal XMENU format that is structured to optimize the display of that panel on a 3270-style terminal. The XMENUCUA control file maintains high level specifications about the panel. This control file is used later when building the complete application dialog and for modifying the XMENU panel.

To save your XMENUCUA control file, use F10 to move the cursor to the File selection of the action bar. Select Save as. The following is displayed:

```
File Edit View Options Help
-----
4 1. New      XMENU CUA Prompter - Create XMENU Menu
  2. Open
-----
          Save
Enter CMS file name then
press enter.
-----
Line  Filename. . . TUTOR0
      F4=Prompt F12=Cancel
Colu-----mber
ts size. Then press Enter.
e menu to take up the whole current
the menu to be as small as possible,
up menu.
1-8 characters
mber, MAX or MIN
Save the XMENU menu. . . Y Y for yes, N for no
Remain in XMEDIT . . . N Y for yes, N for no

Command ==>
F1=Help F3=Exit F9=Retrieve F10=Actions F12=Cancel F21=Command
```

Press Enter to save the control file to your A-disk.

Preparing for a new panel

To return to the XMENUCUA main panel, press F12. Then, so that you can create a new panel in the next section, select File from the action bar. Then, select New. The following screen appears:

```
File Edit View Options Help
-----
1 1. New          XMENU CUA Prompter
2. Open...
3. Save          following. Then press Enter.
4. Save as...
*. Print        ion Bar
6. Exit F3      nel I.D.
                nel Title
-----
4. C           a
5. C           Confirm New      List
*. C           Data already exists.
7. C
8. C           1 1. Clear all data  r Error Message Line
9. C           2. Cancel new
10.           F12=Cancel      Elements
11.           u format
*2. Save the menu in DIALOG Tag Language (DTL) format

Command ==>
F1=Help F3=Exit F9=Retrieve F10=Actions F12=Cancel F21=Command
```

Type / and press Enter.

That's all there is to it ... you've created your main panel. Now let's go on and develop TUTOR1 where you'll learn how to create an entry field.

Chapter 5. Creating a panel with multiple entry fields — TUTOR1

You're now going to create a panel that has multiple entry fields, TUTOR1. TUTOR1 is the panel that you would see if you chose the first selection from the panel you just created (TUTOR0):

```
Exit Help Misc
-----
TUTOR1                      Browse a File
Fill in the CMS file name. You can use '*' and '?' as wildcard
characters when using PF4 to PROMPT. Then press ENTER.
CMS filename. . . . . _____
CMS filetype. . . . . _____
CMS filemode. . . . . ____
BROWSE options. . . . _____

Command ==>
F1=Help F3=Exit F4=Prompt F9=Retrieve F10=Actions F12=Cancel
```

Your terminal screen should now have the main XMENUCUA panel showing.

To create TUTOR1, you'll need to perform nine steps:

- Create an Action Bar
- Create the Panel I.D.
- Create the Panel Title
- Create an Informational Area
- **Create Four Entry Fields**
- Create a Command Area and Error Message Line
- Create a Function Key Area
- Save the menu in XMENU menu format
- Save the control file

Panels should be created in this sequence because certain parts of the panel appear in the order they are created. However, in this chapter you'll also learn how to change the order of panel elements in case you create the panel elements out of sequence.

Creating an entry field

Entry fields are the fields that can accept user input on a panel. Select Create an Entry Field or Protected Text **7** to display the following:

```
File Edit View Options Help
-----
XMECUA7  XMENU CUA Prompter - Create an Entry Field or Protected Text
Enter spacing information, group heading, and entry field data.
Entry name . . . : E1
Heading. . . . .
Field Prompt . . CMS filename
Input size . . . 8 (1-99)
Descriptive Text
Space after. . . Y (N=no space after this line, Y=space after this line)
Protected Text . N (N=entry field, Y=protected text, D=masked input)
Auto Tab Field . N (N=not an Auto Tab field, Y=Auto Tab field)

Command ==>
F1=Help F3=Exit F7=Backward F8=Forward F10=Actions F12=Cancel F21=Command
```

For TUTOR1, you need to create four entry fields. The first one, *CMS filename*, is shown above. Enter *CMS filename* beside Field Prompt. XMENU/DIALOG automatically inserts leader dots (the dots that follow the prompts in the application), so you don't need to worry about those. For input size, enter 8. Everything else can stay as the defaults, since:

- you want a blank line after this entry field (enter *Y* in the Space after field)
- you're creating an entry field (enter *N* in the Protected text field)
- you don't want the cursor to automatically tab to the next input field when the user completely fills this field (enter *N* in the Auto Tab Field field)

After finishing this input, press Enter, then press F8. The Entry Name prompt now displays E2, meaning that you can now create the second entry field. Your remaining three entry fields should be entered as follows:

<u>Entry name</u>	<u>Field Prompt</u>	<u>Input size</u>
E2	CMS filetype	8
E3	CMS filemode	2
E4	BROWSE options	30

Press Enter, then press F12 to return to the XMENUCUA main panel.

Other entries for TUTOR1

Here's a quick outline of the rest of the information you need to create this panel, showing the selections from the XMENUCUA main panel.

Create Action Bar **1**

- Action Bar Item 1. **Exit**
- Action Bar Item 2. **Help**
- Action Bar Item 3. **Misc**

Create Panel I.D. **2** **TUTOR1**

Create Panel Title **3** **Browse a File**

Create Informational Area **4**

Fill in the CMS filename. You can use '*' and '?' as wildcard characters when using PF4 to PROMPT. Then press ENTER.

Create Command Line and Error Message **8**

- Command Area Size **1**
- Error Message Line. **Y**

Create Function Key Area **9**

- F1. **Help**
- F3. **Exit**
- F4. **Prompt**
- F9. **Retrieve**
- F10 **Actions**
- F12 **Cancel**

Create XMENU Menu **11**

- Menu name **TUTOR1**
- Lines in the menu **24**
- Columns in the menu **80**

Save Control File

- Press **F10** then select **File**. Select **Save as**, type **TUTOR1** as the filename, then press **Enter**

However, since you created your entry fields before your informational area, the informational area falls below the entry fields. So, you'll need to change the order of panel elements.

Changing the order of panel elements

When you select Change the order of Panel Elements **10** the following is displayed:

```
File Edit View Options Help
-----
XMECUAOR                XMENU CUA Prompter - Order Panel Components
Modify the order of panel components below. Then press Enter.

Current list
E1    E2    E3    E4    T1

New List
T1    E1    E2    E3    E4

Command ==>
F1=Help F3=Cancel F9=Retrieve F10=Actions F21=Command
```

Again, since you created your entry fields before your informational area, the Current List would appear as shown above. The top list shows the current order of panel elements. You need to change the New List as shown.

- T represents informational area elements (or text area)
- E represents entry area elements
- L represents selection list elements

When you make any changes to the panel order, you must resave the XMENU panel and XMENUCUA control file.

Preparing for a new panel

To return to the XMENUCUA main panel, press F12. Then, so that you can begin with a new panel in the next section, select File from the action bar. Then, select New. When the Confirm New window appears, type / to clear all data.

You've now finished creating a panel with multiple entry fields. Now let's go on and create TUTOR3 where you'll learn how to create a panel with a selection list and entry fields together.

Chapter 6. Creating a panel with entry fields and a selection list — TUTOR3

You're now going to create a panel that has multiple entry fields as well as a selection list, TUTOR3. TUTOR3 is the panel you would see if you chose the third selection from your application's main panel (TUTOR0):

```
Exit Help Misc
-----
TUTOR3                      Move/Copy Files
Select method, enter file name(s), then press Enter.
File method . . . . . _ 1. Copy a file
                        2. Erase a file
                        3. Compare two files
                        4. Rename a file
Input filename. . . . . _____
  filetype. . . . . _____
  filemode. . . . . _____
Output filename . . . . . _____
  filetype . . . . . _____
  filemode . . . . . _____
Command Options . . . . . _____
Command ==>>>
F1=Help F3=Exit F4=Prompt F9=Retrieve F12=Cancel
```

Your terminal screen should now have the main XMENUCUA panel showing.

To create TUTOR3, you'll need to perform ten steps:

- Create an Action Bar
- Create the Panel I.D.
- Create the Panel Title
- Create an Informational Area
- **Create a Selection Field or List**
- **Create Entry Fields**
- Create a Command Area and Error Message Line
- Create a Function Key Area
- Save the menu in XMENU menu format
- Save the control file

You've performed all ten steps previously. However, two of these steps are a little different from the ones before, so we'll review these two and give you a quick overview of the other eight.

Creating a selection list with a field prompt

A field prompt is the message that appears requesting information that must be input — kind of like an introduction to a selection list or entry field. To create a selection list with a field prompt, select Create a Selection Field or List **5** and the following is displayed:

```
File Edit View Options Help
-----
XMENUCUA5          XMENU CUA Prompter - Create a Selection Field or List

Enter the type of list you are generating, group heading, and selections

List Name. . . : L1
List Type. . . : S (S=Single Selection, M=Multiple Selection)
Space after. . : Y (Y=space after this area, N=no space after this area)
Heading. . . .
Field Prompt . . : File method
                                           Item 1 of 50

List items . . . 1. Copy a file
                  2. Erase a file
                  3. Compare two files
                  4. Rename a file

Command ==>
F1=Help F3=Exit F4=Up F5=Down F7=Bkwd F8=Fwd F10=Actions F12=Cancel
```

This selection list is a little different from the one you created for TUTOR0. You need to add a field prompt, *File method*, as shown above. Don't worry about adding the leader dots ... XMENU/DIALOG does that automatically.

Then, enter the List items, remembering to enter the numbers that precede the items. Press Enter, then press F12 to return to the XMENUCUA main panel.

Creating entry fields with variations on spacing

TUTOR3 has several entry fields — seven in all. Select Create an Entry Field or Protected Text **7** to display the following:

```
File Edit View Options Help
-----
XMECUA7  XMENU CUA Prompter - Create an Entry Field or Protected Text
Enter spacing information, group heading, and entry field data.
Entry name . . . : E1
Heading. . . . .
Field Prompt . . Input filename
Input size . . . 8 (1-99)
Descriptive Text
Space after. . . N (N=no space after this line, Y=space after this line)
Protected Text . N (N=entry field, Y=protected text, D=masked input)
Auto Tab Field . N (N=not an Auto Tab field, Y=Auto Tab field)

Command ==>
F1=Help F3=Exit F7=Backward F8=Forward F10=Actions F12=Cancel F21=Command
```

For the first entry field, you'll need to enter the following:

- *Input filename* for the Field Prompt
- *8* for the Input size
- *N* for no space after this line, since the next entry field is directly below this one without a blank line

Then, press F8 and continue entering data until you've finished all seven entry fields; when entering the field prompts, remember to include the spaces that come before some of the prompts:

Entry field	Field Prompt	Input Size	Space after
<i>E2</i>	<i>filetype</i>	<i>8</i>	<i>N</i>
<i>E3</i>	<i>filemode</i>	<i>2</i>	<i>Y</i>
<i>E4</i>	<i>Output filename</i>	<i>8</i>	<i>N</i>
<i>E5</i>	<i>filetype</i>	<i>8</i>	<i>N</i>
<i>E6</i>	<i>filemode</i>	<i>2</i>	<i>Y</i>
<i>E7</i>	<i>Command Options</i>	<i>30</i>	<i>Y</i>

Other entries for TUTOR3

Here's a quick outline of the rest of the information you need to create this panel, showing the selections from the XMENUCUA main panel.

Create Action Bar **1**

- Action Bar Item 1. **Exit**
- Action Bar Item 2. **Help**
- Action Bar Item 3. **Misc**

Create Panel I.D. **2** **TUTOR3**

Create Panel Title **3** **Move/Copy Files**

Create Informational Area **4**

Select method, enter file name(s). Then press Enter.

Create Command Line and Error Message **8**

- Command Area Size **1**
- Error Message Line. **Y**

Create Function Key Area **9**

- F1. **Help**
- F3. **Exit**
- F4. **Prompt**
- F9. **Retrieve**
- F12 **Cancel**

Change the Order of Panel Elements **10** (if necessary)

- New List. **T1 L1 E1 E2 E3 E4 E5 E6 E7**

Create XMENU Menu **11**

- Menu name **TUTOR3**
- Lines in the menu **24**
- Columns in the menu **80**

Save Control File

- Press **F10** then select **File**. Select **Save as**, enter **TUTOR3**, then press **Enter**

Preparing for a new panel

To return to the XMENUCUA main panel, press F12. Then, so that you can begin with a new panel in the next section, press F10 and select File from the action bar. Then, select New. When the Confirm New window appears, type *l* to clear all data.

You're more than halfway there. Now let's go on and create TUTOR5 where you'll learn how to create a panel with multiple selection lists.

Chapter 7. Creating a panel with two selection lists — TUTOR5

You're now going to create a panel that has two selection lists, TUTOR5:

```
Exit Help Misc
-----
TUTOR5                               Miscellaneous CP/CMS Services
Select a service, then press Enter
CMS settings . . . _ 1. GLOBAL MACLIBS, TXTLIBS, and LOADLIBS
                    2. CMS SET Command Settings
CP settings. . . . _ 1. CP SET/TERMINAL command settings

Command ==>
F1=Help F3=Exit F9=Retrieve F10=Actions F12=Cancel
```

Your terminal screen should now have the main XMENUCUA panel showing.

To create TUTOR5, you'll need to perform nine steps:

- Create an Action Bar
- Create the Panel I.D.
- Create the Panel Title
- Create an Informational Area
- **Create Two Selection Lists**
- Create Command and Error Message Area
- Create a Function Key Area
- Save the menu in XMENU menu format
- Save the control file

Creating two selection lists

To create two selection lists, select Create a Selection Field or List **5** and the following is displayed:

```
File Edit View Options Help
-----
XMECUA5          XMENU CUA Prompter - Create a Selection Field or List

Enter the type of list you are generating, group heading, and selections

List Name. . . : L1
List Type. . . : S (S=Single Selection, M=Multiple Selection)
Space after. . : Y (Y=space after this area, N=no space after this area)
Heading. . . .
Field Prompt . : CMS settings
                                           Item 1 of 50
List items . . : 1. GLOBAL MACLIBS, TXTLIBS, and LOADLIBS
                  2. CMS SET Command Settings

Command ==>
F1=Help F3=Exit F7=Backward F8=Forward F10=Actions F12=Cancel F21=Command
```

You'll need to remember a couple of points. First, be sure to enter the Field Prompt and the first List items. Don't worry about the leader dots ... XMENU/DIALOG inserts those automatically. Then, to enter the second selection list, press F8. A new screen will appear with a List Name of L2 and you can enter the details for the CP settings list as shown below:

```
File Edit View Options Help
-----
XMECUA5          XMENU CUA Prompter - Create a Selection Field or List

Enter the type of list you are generating, group heading, and selections

List Name. . . : L2
List Type. . . : S (S=Single Selection, M=Multiple Selection)
Space after. . : Y (Y=space after this area, N=no space after this area)
Heading. . . .
Field Prompt . : CP settings
                                           Item 2 of 50
List items . . : 1. CP SET/TERMINAL command settings

Command ==>
F1=Help F3=Exit F7=Backward F8=Forward F10=Actions F12=Cancel F21=Command
```

Chapter 8. Creating a pop-up window — TUTOR8

Your final XMENUCUA task is to create a Confirm Quit pop-up window identical to the one below:

```
Exit Help Misc
-----
TUTOR0                      XMENU/DIALOG Tutorial
Choose one of the following. Then press Enter.

1. Browse a file
2. Edit a fil
3. Copy, Eras
4. Display a
5. Miscellane

      Confirm Quit
      Do you want to quit?
      2 1. Yes
        2. No
      F12=Cancel

Command ==>
F1=Help F3=Exit F9=Retrieve F10=Actions F12=Cancel
```

You use pop-up windows to show a secondary list of options that appears when a user selects an item in a panel. For example, the pop-up window that you're going to create appears when a user tries to exit from the application.

Your terminal screen should now have the main XMENUCUA panel displayed.

XMENU entries for TUTOR8

We will use the same processes to create TUTOR8 as we did for the other panels, with the exception that we need to disable the command and error message lines. Perform the following steps before going to the next step:

Create Panel Title **3** **Confirm Quit**

Create Informational Area **4**
Do you want to quit?

Create a Selection List **5**
1. Yes
2. No

Create Function Key Area **9**
- F12 Cancel

Disabling the command line and error message line

So that no command line or error message line appears, select Create a Command Area and/or Error Message Line **3** and the following is displayed:

```
File Edit View Options Help
-----
XMECUA8      XMENU CUA Prompter - Create Command and Error Message Areas
Enter the number of lines you want for the Command and/or Error Message
Areas. Then press Enter.
Command Area Size. . . . 0 (0-2)
Error Message Line . . . N (Y=reserve a line for error message, N=no
line

Command ===>
F1=Help F3=Exit F9=Retrieve F10=Actions F12=Cancel F21=Command
```

Keep the command line size as 0, but change the error message line to N so that no error message line is reserved.

Press Enter, then press F12 to return to the XMENUCUA main panel.

Viewing the pop-up window

To view your pop-up window, select Create XMENU Menu **11** and the following is displayed:

```
File Edit View Options Help
-----
XMECUAXM          XMENU CUA Prompter - Create XMENU Menu

Enter the name of the menu, and its size. Then press Enter.
Use MAX for a size if you want the menu to take up the whole current
screen size. Use MIN if you want the menu to be as small as possible,
for example, to be used as a pop-up menu.

Menu name. . . . . TUTOR8    1-8 characters
Lines in the menu. . . . MIN A number, MAX or MIN
Columns in the menu. . . . . A number
Save the XMENU menu. . . . Y Y for yes, N for no
Remain in XMEDIT . . . . N Y for yes, N for no

Command ==>
F1=Help F3=Exit F9=Retrieve F10=Actions F12=Cancel F21=Command
```

Type *TUTOR8* as the Menu name.

Change the number of lines to *MIN*. This will cause a panel of minimum size to be created.

Press Enter and the pop-up window appears. Don't worry that it appears in the top left-hand corner of the screen without a complete border. This will be taken care of later when you complete the dialog.

Press Enter again and the Create XMENU Menu appears again showing the minimum line and column numbers.

```
File Edit View Options Help
-----
XMECUAXM          XMENU CUA Prompter - Create XMENU Menu

Enter the name of the menu, and its size. Then press Enter.
Use MAX for a size if you want the menu to take up the whole current
screen size. Use MIN if you want the menu to be as small as possible,
for example, to be used as a pop-up menu.

Menu name. . . . . TUTOR8  1-8 characters
Lines in the menu. . . . 7  A number, MAX or MIN
Columns in the menu. . . 22 A number
Save the XMENU menu. . . Y Y for yes, N for no
Remain in XMEDIT . . . . N Y for yes, N for no

Command ==>
F1=Help F3=Exit F9=Retrieve F10=Actions F12=Cancel F21=Command
```

Then, to save the control file, press F10 then select File. Select Save as, enter *TUTOR8*, then press Enter

To exit XMENUCUA, press F12 twice. Since you have saved your panel data, select Yes to confirm the quit.

There ... you've finished creating your panels and pop-up window. Your next step is to define the relationship among panels using XTREE, which is described in the following chapter.

Chapter 9. Creating your application dialog using XTREE

Before you begin

So that others can use this tutorial, you need to copy the *DLGTUTOR BACKUP* to *DLGTUTOR MENUTREE*. Only do this if you have not previously completed part of the tutorial, or if you want to start over from the beginning.

To create your application dialog, type *XTREE DLGTUTOR*. This will load the partially-completed application we mentioned earlier. The following screen is displayed:

```
-----  
XMENU Hierarchical Menu Utility  
-----  
      x x tttttt rrrrr eeeee eeeee  
      xx  t  r  r e  e  
----- x  t  rrrrr eeee  eeee -----  
      xx  t  r r e  e  
      x x  t  r rr eeeee eeeee  
  
      Version 1, Release 1, Modification 1  
      Copyright 1990, 1991 - Relay Technology  
      All Rights Reserved  
  
Enter F12=Cancel  
-----
```

Press Enter to continue.

If you want to exit while using XTREE

select the File action bar item and select Save as.... Name the tutorial *DLGTUTOR* and exit the program using F3. When you come back and re-enter XTREE, select the File action bar and select Open to re-open *DLGTUTOR*.

Once XTREE begins, the following is displayed:

```
File Edit View Options Help
-----
XMETRE0                                MENUTREE Prompter Main Menu

Select one of the following. Then press Enter.

1. Select local menu name and menu options.
2. Define local menu parameters.
3. Define local action bar commands.
4. Define local function key commands.
5. Define local selection list commands.
6. Define local command synonyms.
7. Define local MENUEXEC subcommands.
8. Define local error messages.
9. Define global function key commands.
10. Define global command synonyms.
11. Test your MENUTREE application.

Current local section. . . . TOP      1-8 character name

Command ==>
F1=Help F3=Exit F7=Back F9=Retrieve F10=Actions F12=Cancel
```

As shown above in Current local section, XTREE always assumes that the first section is the TOP section. The panel you will use in the TOP section is TUTOR0. You'll also be creating a section for each of the five panels you just created. A section name may have a different name than the panel it will describe, as illustrated by the TOP section. However, the other sections that you are going to create use the same names as the panels that they refer to.

Chapter 10. Defining the dialog for your main panel — TUTOR0

To define the dialog for TUTOR0, you'll need to perform six steps:

- Specifying panel information
- Defining local panel parameters
- Defining local action bar commands
- Defining function key commands
- Defining selection list commands
- Defining error messages

Specifying panel information

From the XTREE main panel, select `Select local menu name and menu options` **1** and the following is displayed:

```
File Edit View Options Help
-----
XMETRE1                      Select MENUTREE Menu and Options Section: TOP
Type this section's menu name and other section options. Then press Enter

Menu Information
Menu name. . . . . TUTOR0  1-8 characters

Load XMENUSAA file?. . . . Y Y for yes, N for no

Commands executed when menu is displayed
Initial command. . . . . Icall initial
Command before display . .
Command after display. . .

Order of user input processing
First. . . . . A A - action bar, D - data, F - function key
Second. . . . . F
Third. . . . . D

Command ===>
F1=Help F3=Exit F9=Retrieve F10=Actions F12=Cancel
```

To fill in the MENUTREE menu and options for the TOP section, perform the following tasks:

1. Type *TUTOR0* as the Menu name.

Note: Be sure to type the numeral **0** and not the letter **O** in the menu name for *TUTOR0* so that no errors will occur later when XMENU/DIALOG is trying to locate the correct menu.

2. Specify *Y* to load the XMENUSAA control file. This requests that data from the corresponding XMENUSAA file (the control file generated by XMENUCUA) be loaded at this time. You should only do this:

- the first time you create the application dialog (which you are now doing)
- when you make any changes to the XMENUSAA file (changes made to the existing panel using XMENUCUA)

After the XMENUSAA file has been loaded, this specification will automatically change to *N*.

3. Since this is the initial panel that a user would see when invoking this application, our tutorial will initialize the entire application before this panel is displayed. You do this by typing *Icall initial* beside the *Initial* command prompt.

What is an ICALL?

An ICALL is an XTREE command that will call a user-written internal or external procedure.

We've provided you with all internal and external procedures you need for this tutorial's application. They're found on the same disk as the panels that were also created for you.

What does ICALL Initial do?

Initial is a subroutine that initializes certain REXX variables and field names for this application.

To return to the XTREE main panel, press Enter, then press F12.

Specifying panel parameters

The panel parameters used in XMENU/DIALOG set up such information as MENUEXEC options, initial cursor position, and default selections. From the XTREE main panel, select Define local menu parameters **2** and the following is displayed:

```
File Edit View Options Help
-----
XMETRE2                Define MENUTREE Selection Parameters Section: TOP
Define MENUEXEC options, initial cursor position, and default selection.
Then press Enter.

Initial Cursor Position
Field Name            1-7 characters

Default Selection
Value. . .           A number, blank if none

MENUEXEC Command Line Parameters
MENUEXEC ( WINDOW TOP ACTION MSG MAP

Typical MENUEXEC parameters include: WINDOW window-name LIB lib-name
ACTION MSG BORDERS PA1 CURPOINT MAP
Enter all MENUEXEC parameters above. Separate each by a blank.
Press the Help function key to display a list and description of common
MENUEXEC parameters.

Command ==>
F1=Help F3=Exit F9=Retrieve F10=Actions F12=Cancel F21=Command
```

For TUTOR0, you need four MENUEXEC Command Line Parameters. MENUEXEC is the XMENU utility used to display panels in the dialog. More information about MENUEXEC can be found in the *XMENU/REXX Interface User's Guide and Reference*.

Some MENUEXEC options are automatically inserted by XTREE; others you will have to enter:

EMSG causes MENUEXEC to display informative messages in case of errors.

MAP maps F13-24 and F25-36 to F01-12.

When you have finished, press Enter, then press F12 to return to the XTREE main panel.

Defining action bar commands

Select Define local action bar commands **3** and the following is displayed:

```
File Edit View Options Help
-----
XMETRE3                MENUTREE Actions Commands          Section: TOP
Enter an action and a command for each action.  Then press Enter.

Action                Command
Exit                  Call TUTOR8
Help                  Call Help
Misc                  Call Bar_Misc Action

Command ===>
F1=Help F3=Exit F9=Retrieve F10=Actions F12=Cancel F21=Command
```

When this panel is first displayed, different information may appear. For instance, to help you provide the right command, XTREE assumes that the command for the Exit action bar item is Call Exit. You need to change the information to call the appropriate exit panel for this tutorial application. In this case, the name of the section to be called when the Exit action bar item is selected is TUTOR8. You will be creating this section later in this tutorial. Also, change the other commands as shown above.

What is a CALL?

A CALL is an XTREE command that makes a call to a section you built using XTREE. This differs from an ICALL, which calls a user-written EXEC or subroutine.

Press Enter then press F12 to return to the XTREE main panel.

Defining function key commands

Select Define local function key commands **4** and the following is displayed:

```
File Edit View Options Help
-----
XMETRE4                MENUTREE Function Key Commands    Section: TOP
Enter a function key and command for each key.  Then press Enter.

Key                Command
PF01                Call Help
PF02
PF03
PF04
PF05
PF06
PF07
PF08
PF09                Retrieve
PF10                Actions
PF11
PF12                Call Tutor8

Command ==>
F1=Help F3=Exit F7=Back F8=Fwd P10=Actions F12=Cancel
```

The valid function keys are displayed to the left. Type the command to be issued (when this key is pressed) in the Command column.

Press Enter then F12 to return to the XTREE main panel.

Defining selection list commands

Select Define local selection list commands **5** and the following is displayed:

```
File Edit View Options Help
-----
XMETRE5          MENUTREE Selection List Commands      Section: TOP
Enter a selection number, field name, and command for each selection
list element. Then press Enter.

Select  Field      Command                                     Value: 1
1       S1C1       Call Tutor1
2       S1C2       Call Tutor2
3       S1C3       Call Tutor3
4       S1C4       Call Tutor4
5       S1C5       Call Tutor5

Command ==>
F1=Help F3=Exit F7=Back F8=Fwd P10=Actions F12=Cancel
```

XTREE automatically assigns the selection number and field name. Your selection list items will be listed below Command. You need to change these commands as shown above.

Press Enter then press F12 to return to the XTREE main panel.

Defining error messages

Select Define MENUTREE error messages **8** and the following is displayed:

```
File Edit View Options Help
-----
XMETRE8                Define MENUTREE Error Messages      Section: TOP
Enter appropriate error message text.  Then press Enter.

Message for Invalid Selection
Text. . . . You have entered an invalid selection.

Message for Invalid Function Key
Text. . . . You have pressed an undefined PF key.

Message for Invalid Command Entry
Text. . . .

Command ==>
F1=Help F3=Exit F9=Retrieve P10=Actions F12=Cancel F21=Command
```

Here, you can customize the messages that a user sees when an invalid selection, undefined function key, or unknown command is entered. If no messages are specified for this section, no error messages will be displayed.

Enter the text for Invalid Selection and Invalid Function Key messages as shown above.

Press Enter then press F12 to return to the XTREE main panel.

You've now finished defining the dialog for the TOP section. Now let's go on and see how TUTOR1 differs.

Chapter 11. Defining the dialog for TUTOR1

Before you begin defining the dialog for TUTOR1, you must first change the Current local section as shown below:

```
File Edit View Options Help
-----
XMETRE0                               MENUTREE Prompter Main Menu

Select one of the following. Then press Enter.

1. Select local menu name and menu options.
2. Define local menu parameters.
3. Define local action bar commands.
4. Define local function key commands.
5. Define local selection list commands.
6. Define local command synonyms.
7. Define local MENUEXEC subcommands.
8. Define local error messages.
9. Define global function key commands.
10. Define global command synonyms.
11. Test your MENUTREE application.

Current local section. . . . TUTOR1 1 to 8 character name

Command ==>
F1=Help F3=Exit F7=Back F9=Retrieve F10=Actions F12=Cancel
```

To define the dialog for TUTOR1, you'll need to perform four steps:

- **Specifying panel information**
- Defining local panel parameters
- Defining local action bar commands
- **Defining function key commands**

We'll review the two steps that are different first, then give you an overview of the other steps you need to complete this section.

Specifying panel information

From the XTREE main panel, select **Select local menu name and menu options** **1** and the following is displayed.

```
File Edit View Options Help
-----
XMETRE1          Select MENUTREE Menu and Options Section: TUTOR1
Type this section's menu name and other section options. Then press Enter

Menu Information
Menu name. . . . . TUTOR1 1-8 characters
Load XMENUSAA file?. . . . Y Y for yes, N for no

Commands executed when menu is displayed
Initial command. . . . .
Command before display . . Icall Restore_rtn TUTOR1
Command after display. . . Icall Save_rtn TUTOR1

Order of user input processing
First. . . . . A A - action bar, D - data, F - function key
Second . . . . . F
Third. . . . . D

Command ==>
F1=Help F3=Exit F9=Retrieve F10=Actions F12=Cancel
```

What do Restore_rtn and Save_rtn do?

Restore_rtn is a subroutine that will restore the values of certain REXX variables (field names) which were previously saved by the Save_rtn subroutine.

Save_rtn is a subroutine that will save the values of certain REXX variables (field names) for later retrieval by the Restore_rtn subroutine.

Enter the commands as shown above.

To return to the XTREE main panel, press Enter then press F12.

Defining function key commands

Select Define local function key commands **4** and the following is displayed:

```
File Edit View Options Help
-----
XMETRE4                MENUTREE Function Key Commands      Section: TUTOR1
Enter a function key and command for each key.  Then press Enter.

Key          Command
PF01         Call Help
PF02
PF03
PF04         Icall Tutorf1 E1 , E2 , E3 / Tutor1
PF05
PF06
PF07
PF08
PF09         Retrieve
PF10         Actions
PF11
PF12         Cancel

Command ==>
F1=Help F3=Exit F7=Back F8=Fwd F10=Actions F12=Cancel
```

Again, when you first display this screen, XTREE will assume different commands for the PF Keys. You need to change the information to match the panel above.

What does Icall Tutorf1 do?

Icall Tutorf1 is an external EXEC that displays a pop-up window with a list of files for the user to choose from.

To define your Enter key, press F8 twice and the following is displayed:

```
File Edit View Options Help
-----
XMETRE4          MENUTREE Function Key Commands   Section: TUTOR1
Enter a function key and command for each key.  Then press Enter.

Key              Command
PA1
PA2
PA3
ENTER            Icall Enter_1 E1 , E2 , E3 , E4

Command ==>
F1=Help F3=Exit F7=Back F8=Fwd F10=Actions F12=Cancel
```

Change the command for the Enter key as shown above.

Now, if a user pressed Enter after entering data in the entry fields, the information would be passed to an EXEC entitled Enter_1.

What does Enter_1 do?
Enter_1 is an external EXEC that will BROWSE a specified file.

Note: The same processing could have been accomplished by specifying appropriate commands in the selection list. Using the Enter procedure demonstrates an alternative method.

Press Enter then press F12 to return to the XTREE main panel.

Other XTREE entries for TUTOR1

Here's a quick outline of the rest of the information you need to define the dialog for this panel.

Define menu parameters **2**

- Command Line Parameters. . WINDOW TUTOR1 ACTION **EMSG MAP**

Define Action Bar Commands **3**

- Exit **Call TUTOR8**
- Help **Call Help**
- Misc **Call Bar_Misc Action**

You've now finished defining the dialog for TUTOR1, so it's time to go on to TUTOR3.

Chapter 12. Defining the dialog for TUTOR3

Before you begin defining the dialog for TUTOR3, you must first change the Current local section as shown below:

```
File Edit View Options Help
-----
XMETRE0                                MENUTREE Prompter Main Menu

Select one of the following. Then press Enter.

1. Select local menu name and menu options.
2. Define local menu parameters.
3. Define local action bar commands.
4. Define local function key commands.
5. Define local selection list commands.
6. Define local command synonyms.
7. Define local MENUEXEC subcommands.
8. Define local error messages.
9. Define global function key commands.
10. Define global command synonyms.
11. Test your MENUTREE application.

Current local section. . . . TUTOR3 1 to 8 character name

Command ==>
F1=Help F3=Exit F7=Back F9=Retrieve F10=Actions F12=Cancel
```

To define the dialog for TUTOR3, you'll need to perform five steps:

- Specifying panel information
- Defining panel parameters
- Defining action bar commands
- Defining function key commands
- Defining error messages

XTREE entries for TUTOR3

Here's a quick outline of the information you need to define the dialog for this panel.

Specify menu information **1**

- Menu name. **TUTOR3**
- Load XMENUSAA file? . . . **Y**
- Command before display **.Icall Restore_rtn TUTOR3**
- Command after display. **.Icall Save_rtn TUTOR3**

Define menu parameters **2**

- Command Line Parameters **.WINDOW TUTOR3 ACTION MSG MAP REXX**

Define Action Bar Commands **3**

- Exit **Call Tutor8**
- Help **Call Help**
- Misc **Call Bar_Misc Action**

Define Function Key Commands **4**

- PF01 **Call Help**
- PF04 **Icall Tutorf1 E1 , E2 , E3 / TUTOR3**
- PF09 **Retrieve**
- PF12 **Cancel**
- Enter **Icall Enter_3 S1 , E1 , E2 , E3 , E4 , E5 , E6 , E7**

Defining Error Messages **8**

- **Invalid Selection Selection missing or invalid.**

You've now finished defining the dialog for TUTOR3, so it's time to go on to TUTOR5.

Chapter 13. Defining the dialog for TUTOR5

Before you begin defining the dialog for TUTOR5, you must first change the Current local section as shown below:

```
File Edit View Options Help
-----
XMETRE0                                MENUTREE Prompter Main Menu

Select one of the following. Then press Enter.

1. Select local menu name and menu options.
2. Define local menu parameters.
3. Define local action bar commands.
4. Define local function key commands.
5. Define local selection list commands.
6. Define local command synonyms.
7. Define local MENUEXEC subcommands.
8. Define local error messages.
9. Define global function key commands.
10. Define global command synonyms.
11. Test your MENUTREE application.

Current local section. . . . TUTOR5 1 to 8 character name

Command ==>
F1=Help F3=Exit F7=Back F9=Retrieve F10=Actions F12=Cancel
```

To define the dialog for TUTOR5, you'll need to perform five steps:

- Specifying panel information
- Defining panel parameters
- Defining action bar commands
- Defining function key commands
- **Specifying the selection list**

Note: Remember, you should always perform Select local menu name and menu options **1** before any other XTREE processes. This allows XTREE to load certain information from the XMENUSAA control file for you.

Specifying the selection list

Select Define local selection list commands **5** and the following is displayed:

```
File Edit View Options Help
-----
XMETRE5          MENUTREE Selection List Commands      Section: TUTOR5
Enter a selection number, field name, and command for each selection
list element. Then press Enter.

Select  Field      Command                               Value: 1
1      S1C1       Icall D1gt4s11
2      S1C2       Icall D1gt4s12
1      S2C1       Icall D1gt4s21

Command ==>
F1=Help F3=Exit F7=Back F8=Fwd P10=Actions F12=Cancel
```

What do these ICALLs do?

D1gt4s11 is an external EXEC that displays a panel showing all accessed MACLIBs, TXTLIBs, and LOADLIBs, allowing you to denote which LIBs should be GLOBALed.

D1gt4s12 is an external EXEC that displays a panel, allowing you to view and change your CMS settings.

D1gt4s21 is an external EXEC that displays a panel, allowing you to view and change your CP TERM settings.

Enter the information as shown, press Enter then press F12 to return to the XTREE main panel.

Other XTREE entries for TUTOR5

Here's a quick outline of the other information you need to define the dialog for this panel.

Specify menu information **1**

- Menu name. TUTOR5
- Load XMENUSAA file?. Y

Define menu parameters **2**

- Command Line Parameters. . . WINDOW TUTOR5 ACTION EMSG MAP

Define action bar commands **3**

- Exit Call Tutor8
- Help Call Help
- Misc Call Bar_Misc Action

Define Function Key Commands **4**

- PF01 Call Help
- PF09 Retrieve
- PF10 Actions
- PF12 Cancel

You've now finished defining the dialog for TUTOR5, so it's time to go on to TUTOR8.

Chapter 14. Defining the dialog for TUTOR8

Before you begin defining the dialog for TUTOR8, you must first change the Current local section as shown below:

```
File Edit View Options Help
-----
XMETRE0                                MENUTREE Prompter Main Menu

Select one of the following. Then press Enter.

1. Select local menu name and menu options.
2. Define local menu parameters.
3. Define local action bar commands.
4. Define local function key commands.
5. Define local selection list commands.
6. Define local command synonyms.
7. Define local MENUEXEC subcommands.
8. Define local error messages.
9. Define global function key commands.
10. Define global command synonyms.
11. Test your MENUTREE application.

Current local section. . . . TUTOR8 1 to 8 character name

Command ==>
F1=Help F3=Exit F7=Back F9=Retrieve F10=Actions F12=Cancel
```

To define the dialog for TUTOR8, you'll need to perform five steps:

- Specifying panel information
- **Defining panel parameters**
- Defining function key commands
- Specifying the selection list
- **Specifying MENUEXEC subcommands**

Note: Remember to perform Select local menu name and menu options **1** first.

Defining panel parameters

From the XTREE main panel, select Define local menu parameters **2** and the following is displayed.

```
File Edit View Options Help
-----
XMETRE2          Define MENUTREE Selection Parameters  Section: TUTOR8
Define MENUEXEC options, initial cursor position, and default selection.
Then press Enter.

Initial Cursor Position
Field Name S1    1-7 characters

Default Selection
Value. . . 2    A number, blank if none

MENUEXEC Command Line Parameters
MENUEXEC ( WINDOW TUTOR8 EMSG MAP BORDERS

Typical MENUEXEC parameters include: WINDOW window-name LIB lib-name
ACTION EMSG BORDERS PA1 CURPOINT MAP
Enter all MENUEXEC parameters above. Separate each by a blank.
Press the Help function key to display a list and description of common
MENUEXEC parameters.

Command ==>
F1=Help F3=Exit F9=Retrieve F10=Actions F12=Cancel F21=Command
```

When the TUTOR8 pop-up window appears, you want the cursor to appear on the input area of the first selection list (S1). To do this, type *S/* for Initial Cursor Position.

Also, to define Default Selection, type 2. This would cause a default value of 2 to appear in the input area of the selection list (S1).

For TUTOR8, you need four MENUEXEC Command Line Parameters. Some are automatically inserted by XTREE; others you will have to enter:

- | | |
|----------------|--|
| EMSG | causes MENUEXEC to display informative messages in case of errors. |
| MAP | maps F13-24 and F25-36 to F1-12. |
| BORDERS | causes pop-up windows to be displayed in borders. |

When you have finished, press Enter then press F12 to return to the XTREE main panel.

Specifying MENUEXEC subcommands

From the XTREE main panel, select Define local MENUEXEC subcommands **7** and the following is displayed.

```
File Edit View Options Help
-----
XMETRE7          Define MENUEXEC Subcommands      Section: TUTOR8

Enter one or more MENUEXEC subcommands, one to a line. Then press Enter.
Information about common MENUEXEC subcommands can be displayed by
pressing the Help function key.

viewport 8 19
txtborde blue

Command ==>
F1=Help F3=Exit F7=Back F8=Fwd F9=Retrieve F10=Actions F12=Cancel
```

What do these subcommands do?

viewport 8 19 tells MENUEXEC to position the pop-up window starting on row 8, column 19 of the terminal.

txtborde blue makes the border of the pop-up window blue.

Enter each subcommand on a separate line as shown. XTREE doesn't check the correctness of these subcommands; you will later use the XTREE test facility to ensure that you have entered these correctly.

Information about MENUEXEC subcommands is found in the *XMENU/REXX Interface User's Guide and Reference*.

To return to the XTREE main panel, press Enter then press F12.

Other XTREE entries for TUTOR8

Here's a quick outline of the other information you need to define the dialog for this panel.

Specify menu information **1**

- Menu name. **TUTOR8**
- Load XMENUSAA file?. **Y**

Specifying the selection list **5**

1	S1C1	exit
2	S1C2	cancel

You've now finished defining the dialog for the panels; now you need to define global function key commands and global commands.

Chapter 15. Defining global function key commands

When you select Define global function key commands **9**, the following is displayed:

```
File Edit View Options Help
-----
XMETRE9          MENUTREE Global Function Key Commands
Enter a function key and command for each global key. Then press Enter.
Key              Command
PF01
PF02
PF03          Call Tutor8
PF04
PF05
PF06
PF07
PF08
PF09
PF10
PF11
PF12

Command ==>
F1=Help F3=Exit F7=Back F8=Fwd F9=Retrieve F10=Actions F12=Cancel
```

You've already defined local function key commands for your individual panels. Global function key commands define commands which will be issued from any panel which does not have a local function key command defined for that PF key. Local function key definitions override global function key definitions.

Enter the information as shown, press Enter, then press F12 to return to the XTREE main panel.

Chapter 16. Defining global commands

When you select Define global command synonyms **10**, the following is displayed:

```
File Edit View Options Help
-----
XMETRE10          MENUTREE Global Command Strings

Enter a command name, minimum abbreviation and command string for each
global command. Then press Enter.

Command  MinSize  Command                               Value: 1
=1       2          Call TUTOR1
=2       2          Call TUTOR2
=3       2          Call TUTOR3
=4       2          Call TUTOR4
=5       2          Call TUTOR5
=X       2          Call TUTOR8
QDISK   2          query disk

Command ==>
F1=Help F3=Exit F7=Back F8=Fwd F9=Retrieve F10=Actions F12=Cancel
```

These global commands provide shortcuts for users. For example, if a user wanted to go to the TUTOR3 screen, =3 could be entered from the command line to get to that screen.

These commands take effect for all sections of the application dialog.

Enter the information as shown, press Enter, then press F12 to return to the XTREE main panel.

Chapter 17. Saving and testing your application dialog

Saving the application dialog

From the XTREE main panel, select File from the action bar and select Save as. The following is displayed:

```
File Edit View Options Help
-----
4 1. New          MENUTREE Prompter Main Menu
  2. Open...
  3. Save        following. Then press Enter.
  4. Save as...
-----options
      Saved file Format
      1 1. Save in MENUTREE format
      2. Save in EXEC format
      F3=Exit F12=Cancel
-----
9. Define global function key commands.
10. Define global command synonyms.
11. Test your MENUTREE application.

Current local section. . . . TUTOR8  1-8 character name

Command ==>
F1=Help F3=Exit F7=Back F9=Retrieve F10=Actions F12=Cancel
```

You should always save your work in MENUTREE format, since this is the only way that you can make any modifications to your work later. So select 1 and a window will appear asking you for a filename.

```

File Edit View Options Help
-----
4 1. New          MENU TREE Prompter Main Menu
   2. Open...
-----
          Save
-----
Enter CMS file name then
press enter.
-----
Filename. . . DLGTUTOR
-----
F4=Prompt F12=Cancel
-----
9. Define global function key commands.
10. Define global command synonyms.
11. Test your MENU TREE application.

Current local section. . . . TUTOR8    1-8 character name

Command ==>
F1=Help F3=Exit F7=Back F9=Retrieve F10=Actions F12=Cancel

```

Type *DLGTUTOR* and press Enter. When reinvoking *XTREE*, entering *XTREE DLGTUTOR* will automatically load your *DLGTUTOR* specifications.

The file you just saved is called *DLGTUTOR MENU TREE*. We will show you how to save your work in *EXEC* format a bit later.

Testing your application dialog

Everything you need to run your sample application is now on your system. We've provided the other panels, external EXECs, and subroutines, so before testing, ensure that you have access to the minidisk where those files were loaded. To test your application dialog, select Test your MENUTREE application **11** and the main panel of your application is displayed:

Note: Selection **11** allows you to test your dialog, ensuring that you have defined all action bar items, selection lists, function keys, and global commands correctly for each panel. However, instead of actually executing any ICALL or CP/CMS commands, a pop-up window is displayed simply showing the command to be executed. This is because in this mode, XTREE is simulating the application and not really executing it fully.

```
Exit Help Misc
-----
TUTOR0                                XMENU/DIALOG Tutorial
Choose one of the following. Then press Enter.

1. Browse a file
2. Edit a file
3. Copy, Erase, Compare, Rename file(s)
4. Display a list of CMS files
5. Miscellaneous CP/CMS services

Command ==>
F1=Help F3=Exit F9=Retrieve F10=Actions F12=Cancel
```

Test all action bar items, selection lists, function keys, and command line commands you defined. If an error has been made which does not allow you to quit testing, you can use XTREE's hot key — PA2. Only in test mode will PA2 allow you to exit the tested dialog and return to the XTREE main panel.

If you have errors in your control file, compare your file to the one listed in Appendix A of this tutorial. Then, review the section that pertains to the error and correct the appropriate section.

There, you've finished creating your application. In the next chapter, you'll learn how to test your application dialog using the MENUTREE program and run your dialog using XTRECOMP.

Chapter 18. Testing and running your application dialog

The `MENUTREE` program is used to test your application dialog. To run `MENUTREE`, type:

```
MENUTREE DLGTUTOR
```

`MENUTREE` only processes the control file and `ICALLs` to external routines. Internal routines are not executed. You will get informational messages whenever an `ICALL` is attempted to an internal routine while testing your application, but your testing can continue.

After you have tested your application using `MENUTREE`, you should use `XTRECOMP` to run your application. You can generate a stand-alone `REXX EXEC` from your `MENUTREE` control file by using `XTRECOMP`. To run `XTRECOMP`, type:

```
XTRECOMP DLGTUTOR (APPEND TUTORSUB
```

The resulting `EXEC` is called *DLGTUTOR EXEC*.

Note: If you have a `REXX` compiler, you can further improve performance by compiling the stand-alone `EXEC`. Now, to run your tutorial, type `DLGTUTOR` at the `CMS` command line.

To see what your `MENUTREE` control file should look like, go to the appendix that follows.

Appendix. Your completed MENUTREE file

Now that you have finished, compare your MENUTREE file to the one listed below. Don't worry if the sections of your MENUTREE file are in a different sequence from the one shown here. It's important only that each section contains the same information.

```
Global_Cmd =1 2 call tutor1
Global_Cmd =2 2 call tutor2
Global_Cmd =3 2 call tutor3
Global_Cmd =4 2 call tutor4
Global_Cmd =5 2 call tutor5
Global_Cmd =X 2 call tutor8
Global_Cmd QDISK 2 query disk
Keys PF03 call tutor8
```

TOP: TUTOR0 (window TOP action msg map

```
Order A F D
Initially Icall Initial
Action Exit Call tutor8
Action Help Call Help
Action Misc Call bar_misc action
Selection 1 S1C1 call tutor1
Selection 2 S1C2 call tutor2
Selection 3 S1C3 call tutor3
Selection 4 S1C4 call tutor4
Selection 5 S1C5 call tutor5
Message Selection You have entered an invalid selection.
Message Pfkey You have pressed an undefined PFkey
PF01 call help
PF09 Retrieve
PF10 Actions
PF12 call tutor8
```

TUTOR1: TUTOR1 (window TUTOR1 action msg map

```
Order A F D
Before ical restore_rtn tutor1
After ical save_rtn tutor1
Action Exit call tutor8
Action Help Call Help
Action Misc Call bar_misc action
PF01 call help
PF04 ical tutorfl E1 , E2 , E3 / tutor1
PF09 Retrieve
PF10 Actions
PF12 Cancel
Enter Icall enter_1 E1 , E2 , E3 , E4
```

TUTOR2: TUTOR2 (window TUTOR2 action emsg map

```
Order A F D
Before icall restore_rtn tutor2
After icall save_rtn tutor2
Action Exit call tutor8
Action Help Call Help
Action Misc Call bar_misc action
PF01 call help
PF04 icall tutorfl E1 , E2 , E3 / tutor2
PF09 Retrieve
PF10 Actions
PF12 cancel
Enter icall enter_2 E1 , E2 , E3 , E4 , E5
```

TUTOR3: TUTOR3 (window TUTOR3 action emsg map rexx

```
Order A F D
Before icall restore_rtn tutor3
After icall save_rtn tutor3
Action Exit Call tutor8
Action Help Call Help
Action Misc Call bar_misc action
Selection 1 S1C1 * 1. Copy a file
Selection 2 S1C2 * 2. Erase a file
Selection 3 S1C3 * 3. Compare two files
Selection 4 S1C4 * 4. Rename a file
Message Selection Selection missing or invalid.
PF01 call help
PF04 icall tutorfl E1 , E2 , E3 / tutor3
PF09 Retrieve
PF12 Cancel
Enter icall enter_3 S1 , E1 , E2 , E3 , E4 , E5 , E6 , E7
```

TUTOR4: TUTOR4 (window TUTOR4 action emsg map

```
Order A F D
Before icall restore_rtn tutor4
After icall save_rtn tutor4
Action Exit Call tutor8
Action Help Call Help
Action Misc Call bar_misc action
PF01 call help
PF09 Retrieve
PF10 Actions
PF12 Cancel
Enter icall enter_7 E1 , E2 , E3
```

TUTOR5: TUTOR5 (window TUTOR5 action emsg map

```
Order A F D
Action Exit Call tutor8
Action Help Call Help
Action Misc Call bar_misc action
Selection 1 S1C1 icall dlgt4s11
Selection 2 S1C2 icall dlgt4s12
Selection 1 S2C1 icall dlgt4s21
PF01 call help
PF09 Retrieve
PF10 Actions
PF12 Cancel
```

TUTOR8: TUTOR8 (window TUTOR8 emsg map borders

```
Subcmd viewport 8 19
Subcmd txtborde blue
Order A F D
Cursor s1
Defsel 2
Selection 1 S1C1 exit
Selection 2 S1C2 cancel
PF12 Cancel
```

HELP: TUTOR13 (window HELP emsg map curpoint borders

```
Subcmd txtborde blue
Subcmd viewport 2 8
Order A F D
Selection 1 S1C1 icall help_all S1 , S1C1
Selection 2 S1C2 icall help_all S1 , S1C2
Selection 3 S1C3 icall help_all S1 , S1C3
Selection 4 S1C4 icall help_all S1 , S1C4
Selection 5 S1C5 icall help_all S1 , S1C5
Selection 6 S1C6 icall help_all S1 , S1C6
PF12 cancel
Enter icall help_all S1 , Curfnam
```

BAR_MISC: MISC_BAR (window BAR_MISC emsg map curpoint borders

```
Subcmd viewport 2 14
Subcmd txtborde blue
Order A F D
Before icall save_bar
Cursor s1
Defsel 1
Selection 1 S1C1 * 1. Selection One
Selection 2 S1C2 * 2. Selection Two
Selection 3 S1C3 * 3. Selection Three
Selection 4 S1C4 * 4. Selection Four
Selection 5 S1C5 * 5. Selection Five
PF12 cancel
Enter icall misc_all S1
```

Glossary

A

ACTION. A required MENUEXEC command line parameter whenever the panel which is to be displayed has an action bar defined.

action bar. The area at the top of a XMENU/DIALOG screen that lists and provides access to actions available from the current panel. You select an action by placing the cursor on the action and pressing the Enter key.

auto tab field. A field in which a cursor automatically tabs to the next input field when a user completely fills the first field.

B

BORDERS. A MENUEXEC command line parameter that causes pop-up windows to be displayed in borders.

C

CALL. An XTREE command that makes a call to a section you built using XTREE.

CUA. Common User Access.

D

default value. A value assumed when no value has been specified.

dialog. The hierarchy of the panels in your application; how your panels communicate with each other.

Dlgt4s11. An external EXEC that displays a panel showing all accessed MACLIBs, TXTLIBs, and LOADLIBs, allowing you to denote which LIBs should be GLOBALed (TUT4VLIB).

Dlgt4s12. An external EXEC that displays a panel allowing you to view and change your CMS settings (TUT4CMSS).

Dlgt4s21. An external EXEC that displays a panel allowing you to view and change your CP TERM settings (TUT4CPS).

E

EMSG. A MENUEXEC command line parameter that causes MENUEXEC to display informative messages in case of errors.

Enter_1. An external EXEC that will BROWSE a specified file.

entry field. An area on a panel that requires a set of characters for input.

EXEC. A CMS function that allows users to create new commands by setting up frequently used sequences of CP commands, CMS commands, or both, together with conditional branching facilities.

F

function key. Any key that causes a device to perform a predefined operation.

G

Global function key commands. Commands which will be issued from any panel that does not have a local function key command defined for that PF key.

H

HMF. Hierarchical Menu Facility.

I

ICALL. An XTREE command that will call a user-written internal or external procedure.

Informational area. The area on a panel which gives instructions to a user on how to use the panel or what information is needed.

Initial subroutine. An ICALL that initializes certain REXX variables and field names for this application.

L

leader dots. The dots that go from a prompt to an input field.

LOADLIB. Load library. A CMS disk file containing executable programs called members.

Local function key commands. Commands to be issued from a specified panel.

M

MACLIB. Macro library. A CMS disk file containing macros and COPY files for inclusion when a program is assembled or compiled.

macros. Set of statements defining the name of, format of, and conditions for generating a sequence of assembler statement from a single source statement.

MAP. A MENUEXEC command line parameter that maps F13-24 and F25-36 to F1-12.

MENUEXEC. The XMENU utility used to display panels in the dialog.

MENUTREE control file. Control file containing source statements which define an application's dialog.

P

panel. A display that covers the entire screen. Each panel has an action bar, function key area, and other panel components.

panel I.D.. A 1- to 8-character name for a panel; similar to a filename for a CMS file.

panel title. A panel element that identifies the type of information contained on an XMENU/DIALOG panel.

pop-up window. An area of a screen with visible boundaries through which a panel or portion of a panel is displayed. Windows may appear when you select a choice in a pull-down menu.

pull-down menu. A pull-down extension of the action bar that contains a list of choices available for a selected XMENU/DIALOG action.

R

Restore_rtn subroutine. Restores the values of certain REXX variables (fieldnames) which were previously saved by the Save_rtn subroutine.

S

SAA. System Applications Architecture.

Save_rtn subroutine. Saves the values of certain REXX variables (fieldnames) for later retrieval by the Restore_rtn subroutine.

selection list. A list on a XMENU/DIALOG panel that contains choices from which users can select one or more.

subroutine. A group of instructions that can be called externally or internally by the XMENU/DIALOG program. For example, `ICALL Initial` is a subroutine.

T

Tutorfl. An external EXEC that displays a pop-up window with a list of files for the user to choose from.

Txtborde. A MENUEXEC subcommand that colors the border of a pop-up window.

TXTLIB. Text library. A CMS disk file containing several object files, to be combined when the program is linkage edited. TXTLIBs differ from LOADLIBs in that LOADLIB members are already partially linkage edited, while TXTLIB members are not.

V

Viewport. A MENUEXEC subcommand that positions a pop-up window on a terminal.

W

WINDOW. A MENUEXEC command line parameter always generated by XTREE. A window name is the same as the section name.

X

XMENUCUA. Component of XMENU/DIALOG that allows you to create CUA-compliant panels.

XMENU/DIALOG. A full-function panel generator and dialog manager that allows you to interactively design panels and define the dialog that control user movement between those panels.

XMENUSAA control file. The control file that contains all information input while creating panels using XMENUCUA.

XTRECOMP. An application processor that generates a stand-alone REXX EXEC from your MENUTREE control file.

XTREE. Component of XMENU/DIALOG that allows you to control the order and display of panels that you create with XMENUCUA.

Index

A

- action bar
 - creating 11
- action bar commands
 - defining 46
- application dialog
 - creating 41
 - saving 71
 - testing 73
- application overview 4

C

- CALLs 46
- changing
 - order of panel elements 25
- command line
 - creating 16
 - disabling 37
- completed MENUTREE file 77
- creating
 - action bar 11
 - command line and error message line 16
 - entry fields 24, 29
 - function key area 17
 - informational area 14
 - panel I.D. 12
 - panel title 13
 - panels 7
 - pop-up window 35
 - selection lists 15, 32
 - selection lists with a field prompt 28
 - TUTOR0 9
 - TUTOR1 23
 - TUTOR3 27
 - TUTOR5 31
 - TUTOR8 35
 - your application dialog 41

D

- defining
 - action bar commands 46
 - error messages 49
 - function key commands 47, 53
 - global commands 69
 - global function key commands 67
 - panel parameters 64
 - selection list commands 48
 - TUTOR0 dialog 43

- defining (*continued*)
 - TUTOR1 dialog 51
 - TUTOR3 57
 - TUTOR5 59
 - TUTOR8 dialog 63
- disabling
 - command line and error message line 37
- DLG_MSTR EXEC 3
- DLG_MSTR MENUTREE control file 3
- Dlgt4s11 ICALL 60
- Dlgt4s12 ICALL 60
- Dlgt4s21 ICALL 60
- DLGTUTOR MENUTREE 3

E

- Enter_1 EXEC 54
- entry fields
 - creating 24, 29
- error message line
 - creating 16
 - disabling 37
- error messages
 - defining 49
- EXECs
 - Dlgt4s11 60
 - Dlgt4s12 60
 - Dlgt4s21 60
 - Enter_1 54

F

- field prompts
 - in selection lists 28
- files on the product distribution tape 3
- function key area
 - creating 17
- function key commands
 - defining 47, 53

G

- global commands
 - defining 69
- global function key commands 67
 - defining 67

I

- ICALLs 44
 - Dlgt4s11 60

ICALLs (continued)

- Dlgt4s12 60
- Dlgt4s21 60
- Initial 44
- Tutorfl 53
- informational area
 - creating 14
- Initial ICALL 44
- introducing
 - XMENU/DIALOG 1

L

- local function key commands 53

M

- MENUEXEC subcommands
 - specifying 65
 - txtborde 65
 - viewport 65
- MENUTREE 75

N

- new panel
 - preparing for 21, 26, 30, 33
- notational conventions 11

O

- order of panel elements
 - changing 25
- overview of application 4

P

- panel elements
 - changing order of 25
- panel I.D.
 - creating 12
- panel information
 - specifying 43, 52
- panel parameters
 - defining 64
 - specifying 45
- panel title
 - creating 13
- panels
 - creating 7
- pop-up window
 - creating 35
 - viewing 38
- preparing
 - for a new panel 21, 26, 30, 33
- product distribution tape, files on 3

R

- Restore_rtn subroutine 52
- running your application
 - MENUTREE 75
 - XTRECOMP 75

S

- Save_rtn subroutine 52
- saving
 - application dialog 71
 - XMENU panel 18
 - XMENUCUA control file 20
- selection list commands
 - defining 48
- selection lists
 - creating 15, 28, 32
 - specifying 60
- spacing variations on entry fields 29
- specifying
 - MENUEXEC subcommands 65
 - panel information 43, 52
 - panel parameters 45
 - selection lists 60
- subroutines
 - Initial 44
 - Restore_rtn 52
 - Save_rtn 52

T

- testing
 - application dialog 73
- TUTOR0
 - creating 9
- TUTOR0 dialog
 - defining 43
- TUTOR1
 - creating 23
- TUTOR1 dialog
 - defining 51
- TUTOR3
 - creating 27
 - defining 57
- TUTOR5
 - creating 31
 - defining 59
- TUTOR8
 - creating 35
- Tutorfl ICALL 53
- txtborde subcommand 65

U

- Using XTREE 41

V

viewing

pop-up window 38

viewport subcommand 65

X

XMENU panel

saving 18

XMENU/DIALOG

introducing 1

XMENUCUA 1

XMENUCUA control file

saving 20

XTRECOMP 75

XTREE 1, 41

