

BrightStor[®] ARCserve[®] Backup for Windows

Enterprise Option for SAP R/3 for Oracle Guide

r11.5



Computer Associates*

D01187-1E

This documentation and related computer software program (hereinafter referred to as the "Documentation") is for the end user's informational purposes only and is subject to change or withdrawal by Computer Associates International, Inc. ("CA") at any time.

This documentation may not be copied, transferred, reproduced, disclosed or duplicated, in whole or in part, without the prior written consent of CA. This documentation is proprietary information of CA and protected by the copyright laws of the United States and international treaties.

Notwithstanding the foregoing, licensed users may print a reasonable number of copies of this documentation for their own internal use, provided that all CA copyright notices and legends are affixed to each reproduced copy. Only authorized employees, consultants, or agents of the user who are bound by the confidentiality provisions of the license for the software are permitted to have access to such copies.

This right to print copies is limited to the period during which the license for the product remains in full force and effect. Should the license terminate for any reason, it shall be the user's responsibility to return to CA the reproduced copies or to certify to CA that same have been destroyed.

To the extent permitted by applicable law, CA provides this documentation "as is" without warranty of any kind, including without limitation, any implied warranties of merchantability, fitness for a particular purpose or noninfringement. In no event will CA be liable to the end user or any third party for any loss or damage, direct or indirect, from the use of this documentation, including without limitation, lost profits, business interruption, goodwill, or lost data, even if CA is expressly advised of such loss or damage.

The use of any product referenced in this documentation and this documentation is governed by the end user's applicable license agreement.

The manufacturer of this documentation is Computer Associates International, Inc.

Provided with "Restricted Rights" as set forth in 48 C.F.R. Section 12.212, 48 C.F.R. Sections 52.227-19(c)(1) and (2) or DFARS Section 252.227-7013(c)(1)(ii) or applicable successor provisions.

© 2005 Computer Associates International, Inc.

All trademarks, trade names, service marks, and logos referenced herein belong to their respective companies.

Contents

Chapter 1: Introducing the Option	7
Architectural Overview	8
Option Integration with SAP R/3 for Oracle	9
How SAPDBA Backs Up Data	9
How SAPDBA Restores Data	10
Option Integration with BrightStor ARCserve Backup	11
How BrightStor ARCserve Backup Backs Up Data	12
How BrightStor ARCserve Backup Restores Data	13
Option Integration with the Oracle Recovery Manager	14
How Recovery Manager Backs Up Data	15
How Recovery Manager Restores Data	16
Chapter 2: Installing the Option	17
Installation Prerequisites	17
Hardware and Software Requirements	17
Option Installation	17
Installation Considerations	18
Configure Oracle Server	18
ARCHIVELOG Mode	19
Enable Automatic Archiving	20
Customize the Option to Support RMAN	21
SAPDBA Configuration	22
Configure Parameter File Settings	22
Configure the init<SID>.sap File	26
Create ACLs (Access Control Lists)	26
Log File Purging	27
Disable Log File Purging	27
Enable Log File Purging	28
Check the Status of the Option	29
Remove the Option	30
Chapter 3: Using the Option	31
Online Redo Log Files	31
Multiple Databases	31
Configure a Backup Session for Multiple Databases	32

Database Backup	32
Back Up Online Databases with BrightStor ARCserve Backup.....	33
Back Up Offline Databases with BrightStor ARCserve Backup	35
Back Up in an Oracle Fail Safe Environment with BrightStor ARCserve Backup	36
Oracle Recovery Manager Backup	37
Database Restore with the Option.....	39
Restore a Database with BrightStor ARCserve Backup.....	39
Restore in an Oracle Fail Safe Environment	44
Oracle Recovery Manager Restore	45
Restore to a Particular Point in Time.....	47
Archive Logs Restore.....	48
Database Recovery	48
Recover Complete Databases	49
Recover Complete Databases with Backed Up Control Files	50
Recover Tablespaces or Data Files.....	52
Recover From Offline Full Backups	53
Backup and Restore Limitations.....	53
Chapter 4: Using the Option with Oracle SAPDBA	55
SAPDBA.....	55
SAPDBA Functions.....	56
Database Backup Using SAPDBA	56
Back Up Online Databases with SAPDBA	57
Back Up Offline Databases with SAPDBA	59
Back Up Offline Redo Logs	60
Restore and Recover Using SAPDBA.....	61
The BACKINT Job Status	62
Chapter 5: Best Practices	63
Recommended Backup Procedures.....	63
Effective Backup and Recovery Strategies.....	64
Test Environment.....	64
Log File Protection.....	64
Backups After Organizational Changes	65
Current Option Information	65

Appendix A: Troubleshooting	67
Debug Methods.....	67
Enable Debugging for the Option	67
Enable Debugging for the Backup Option Integration Module.....	69
Registry Settings for RMAN Support	70
Option Activity Log File	72
Job Status Information	72
Database Manager	73
BACKINT Job Status	74
Appendix B: Disaster Recovery	75
Scenarios for Restoring to the Original Windows Server	75
Recover the ORCL Database.....	76
Recover the DB2 Database.....	77
Scenarios for Restoring to an Alternate Server	78
Restore to a Server that Supports Exact Directory Structures.....	79
Restore to a Server with Different Directory Structures	80
Appendix C: Sample util_par_file and Parameter Definitions	83
Sample File.....	83
Parameter Definitions	84
Remote Section.....	85
Volume Brbackup Section	85
Volume Brarchive Section	86
Internal Section.....	86
Index	87

Chapter 1: Introducing the Option

Among the options BrightStor ARCserve Backup offers is the BrightStor® ARCserve® Backup Enterprise Option for SAP R/3 for Oracle (the option). This option helps you manage Oracle databases in your SAP R/3 for Oracle environment by letting you remotely manage backups, schedule your backups, and back up to a wide array of media storage devices.

The option supports backup and restore operations launched from the BrightStor ARCserve Backup user interface or from the following user interfaces:

- SAPDBA for Oracle
- Oracle Recovery Manager

Using the option, you can back up and restore the following Oracle database objects:

- Databases
- Tablespaces
- Archived log files
- Control files

The option handles all communications between BrightStor ARCserve Backup, SAP R/3 for Oracle, and the Oracle server application while data is being backed up and restored. This includes preparing, retrieving, and processing the data sent back and forth across the network.

Architectural Overview

You can install BrightStor ARCserve Backup on the same computer as the option and the Oracle database, or on a separate computer. If you install BrightStor ARCserve Backup on the same computer, then communication with the option is local. If you install it on a separate computer, BrightStor ARCserve Backup communicates with the option remotely over a LAN or WAN.

An Oracle *instance* is a logical database server environment. You can create an Oracle database within an Oracle instance on your database server. The option provides services that allow BrightStor ARCserve Backup to back up and restore a SAP-managed Oracle database associated with the option. The networking capabilities of BrightStor ARCserve Backup enable the option to be located on any Windows server on which an Oracle database is located. You must install one option on each database server that you want BrightStor ARCserve Backup to manage. The following diagram illustrates the basic architecture of BrightStor ARCserve Backup and the Enterprise Option for SAP R/3 for Oracle:

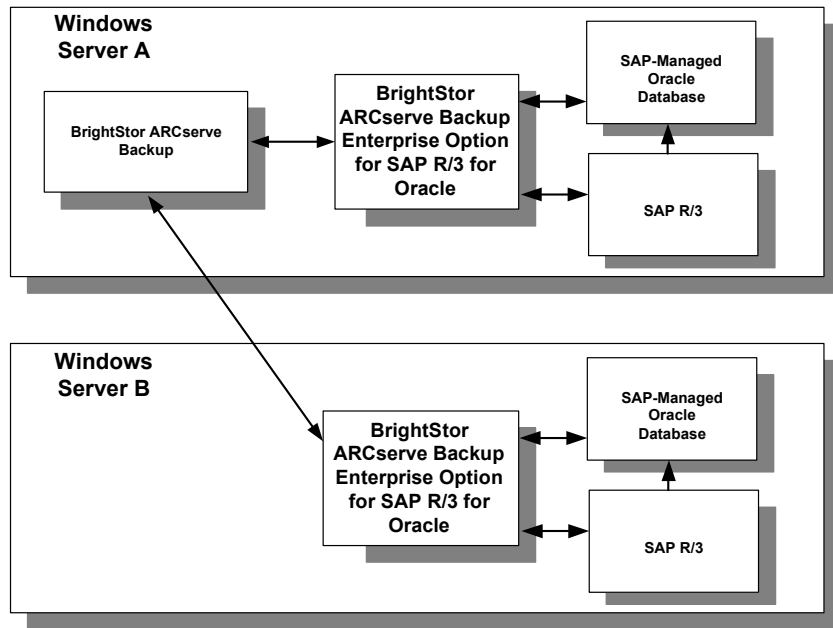

Note: Staging is not supported when you back up the database using SAPDBA.

Option Integration with SAP R/3 for Oracle

The Enterprise Option for SAP R/3 for Oracle lets you to back up and restore SAP-managed Oracle databases by integrating with SAPDBA for Oracle, the database administration tool developed by SAP for managing Oracle databases. The option's backup option integration module implements this integration provided by Computer Associates. This module is installed when the option is installed.

The backup option integration module links BrightStor ARCserve Backup to SAPDBA for Oracle. The SAPDBA module manages the activity within the Oracle database, and the backup option integration module manages the backup, restore, and inquiry requests in conjunction with BrightStor ARCserve Backup. The backup option integration module is referred to as both BACKINT and as BC-BRI in SAP documentation.

For the option to be able to use SAPDBA, the SAP R/3 for Oracle application must be running. When SAPDBA starts a backup or restore job, the backup option integration module is automatically invoked.

How SAPDBA Backs Up Data

The following diagram illustrates how the option performs backups using SAPDBA:

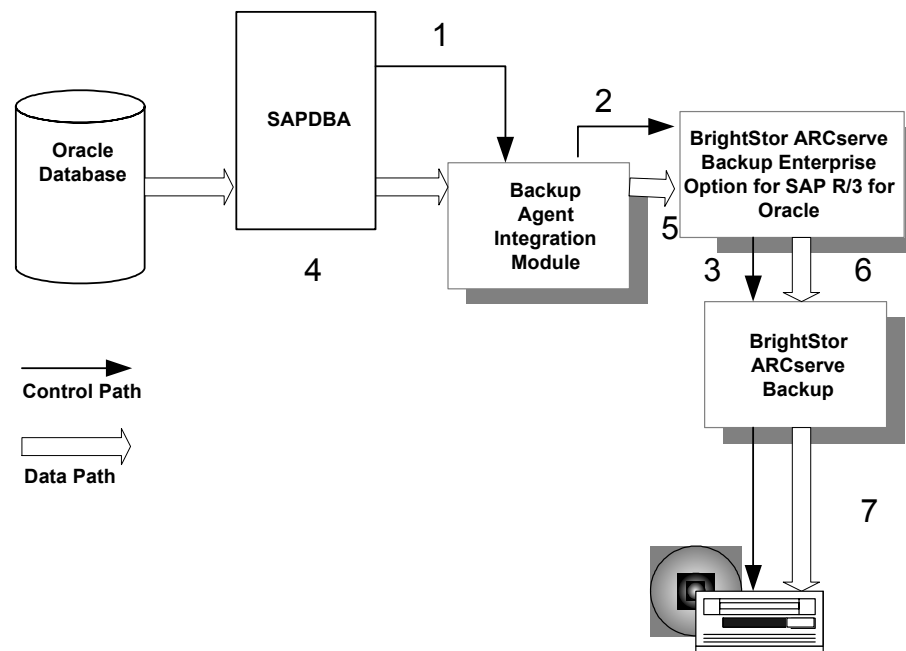

The following describes each step in the process, as shown in the diagram:

1. A user issues a backup command from the SAPDBA user interface.
SAPDBA directs the request to the backup option integration module.
2. The backup option integration module receives the backup request and passes it to the option.
3. The option passes the backup request to BrightStor ARCserve Backup.
4. SAPDBA begins copying backup data from the database and passes it to the backup option integration module.
5. The backup option integration module passes the backup data to the option.
6. The option passes the backup data to BrightStor ARCserve Backup.
7. BrightStor ARCserve Backup saves the data to a storage medium.

How SAPDBA Restores Data

The following diagram illustrates how the option restores Oracle objects with SAPDBA:

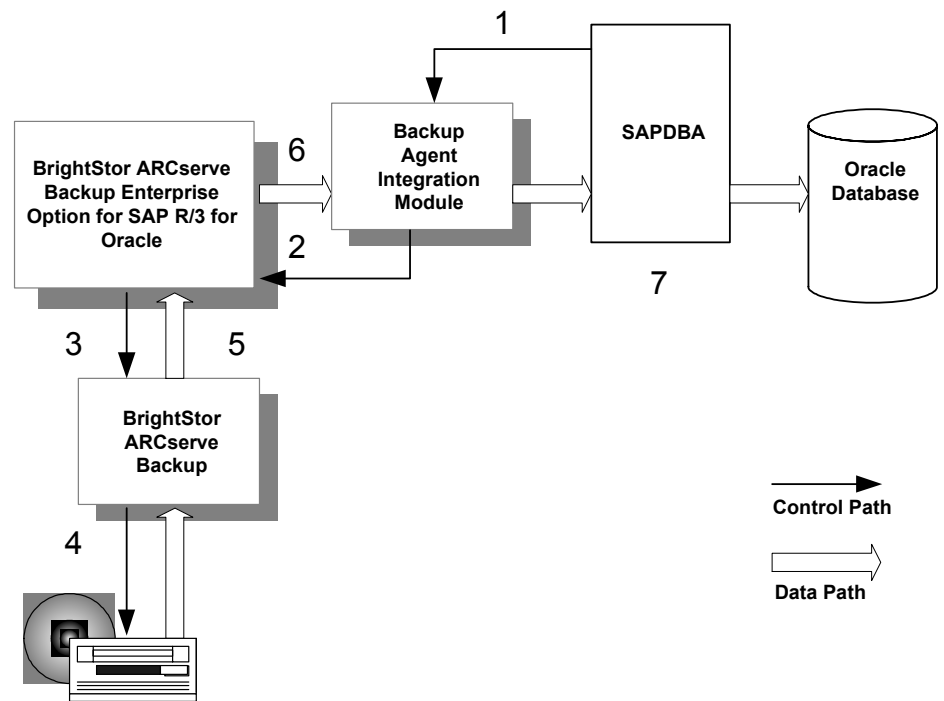

The following describes each step in the process, as shown in the diagram:

1. A user issues a restore command from the SAPDBA user interface.
SAPDBA directs the request to the backup option integration module.
2. The backup option integration module receives the restore request and passes it to the option.
3. The option passes the restore request to BrightStor ARCserve Backup.
4. BrightStor ARCserve Backup retrieves the data from a storage medium.
5. BrightStor ARCserve Backup passes the restore data to the option.
6. The option passes the restore data to the backup option integration module.
7. SAPDBA restores the data to the database.

Option Integration with BrightStor ARCserve Backup

You can use the option to perform backups and restores submitted from the BrightStor ARCserve Backup user interface. The diagrams in the following sections outline the general interaction between the option and BrightStor ARCserve Backup.

How BrightStor ARCserve Backup Backs Up Data

The following diagram illustrates how the option performs backups using BrightStor ARCserve Backup:

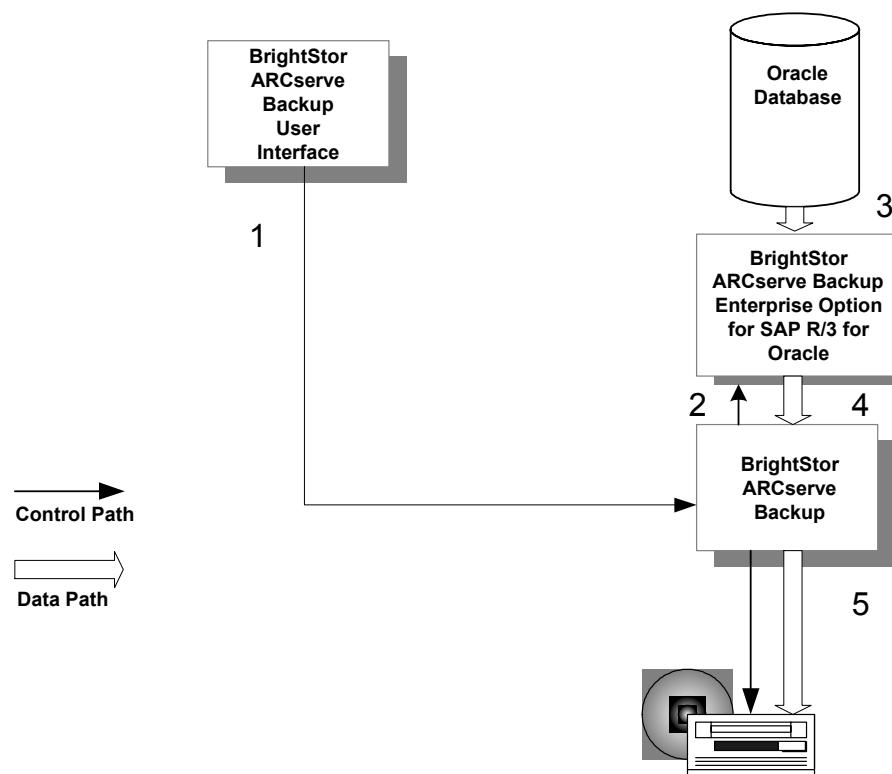

The following describes each step in the process, as shown in the diagram:

1. The user issues a backup command from the BrightStor ARCserve Backup user interface.
2. BrightStor ARCserve Backup receives the backup request and passes it to the option.
3. The option begins copying backup data from the database.
4. The option passes the backup data to BrightStor ARCserve Backup.
5. BrightStor ARCserve Backup saves the data to a storage medium.

How BrightStor ARCserve Backup Restores Data

The following diagram illustrates how the option restores Oracle objects with BrightStor ARCserve Backup.

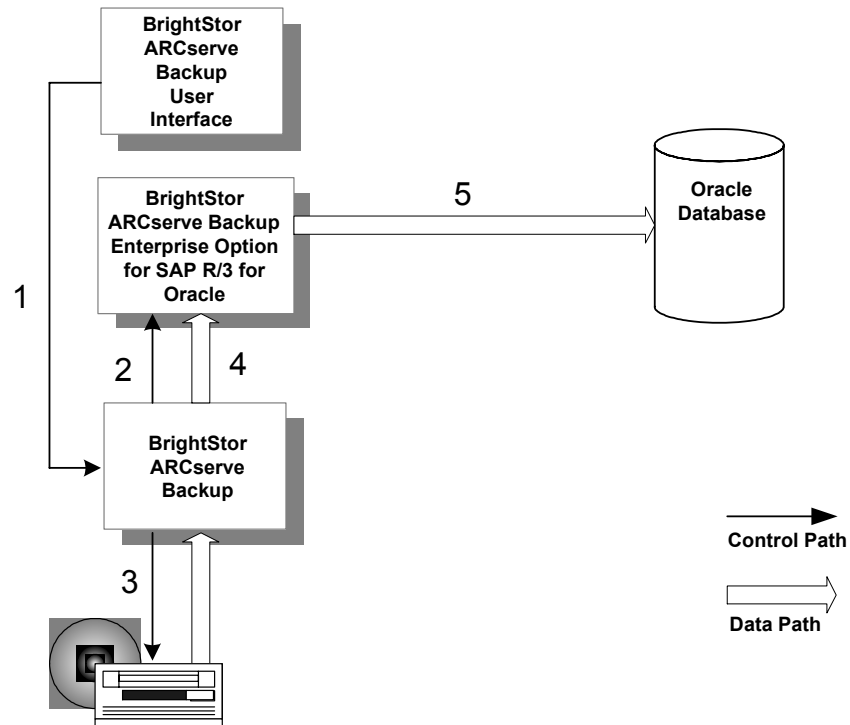

Note: When you restore with BrightStor ARCserve Backup, you can only restore data that was backed up with BrightStor ARCserve Backup.

The following describes each step in the process illustrated the diagram:

1. The user issues a restore command from the BrightStor ARCserve Backup user interface.
2. BrightStor ARCserve Backup informs the option of the restore request.
3. BrightStor ARCserve Backup begins retrieving the data from storage.
4. BrightStor ARCserve Backup passes the data to the option.
5. The option restores the data to the database.

Option Integration with the Oracle Recovery Manager

During installation, you have the option of installing support for Oracle Recovery Manager (RMAN), an Oracle utility for backing up, restoring, and recovering Oracle databases. With support for Recovery Manager, you can submit backup and restore jobs to BrightStor ARCserve Backup by connecting to RMAN at the command line, or through the Oracle Backup Manager user interface. In addition, you can write and execute your own Recovery Manager scripts.

If you choose to install BrightStor ARCserve Backup support for Recovery Manager, you must run the Oracle Backup Agent Configuration for Recovery Manager utility before you use Recovery Manager.

For information on how to run this utility, see the section Configure BrightStor ARCserve Backup for Use with Recovery Manager in the "Installing the Option" chapter.

After you install the BrightStor ARCserve Backup Enterprise Option for SAP R/3 for Oracle, each time you initiate a backup or restore with Recovery Manager, the option transfers data between BrightStor ARCserve Backup, the Oracle database, and the storage media.

If you back up data using the Recovery Manager interface, you can only restore that data using the Recovery Manager interface. Similarly, if you back up data using BrightStor ARCserve Backup, you can only restore that data using BrightStor ARCserve Backup.

For more information on Recovery Manager, see the *Oracle Backup and Recovery Guide*.

How Recovery Manager Backs Up Data

The following diagram illustrates how you can process backup jobs initiated from Oracle Recovery Manager:

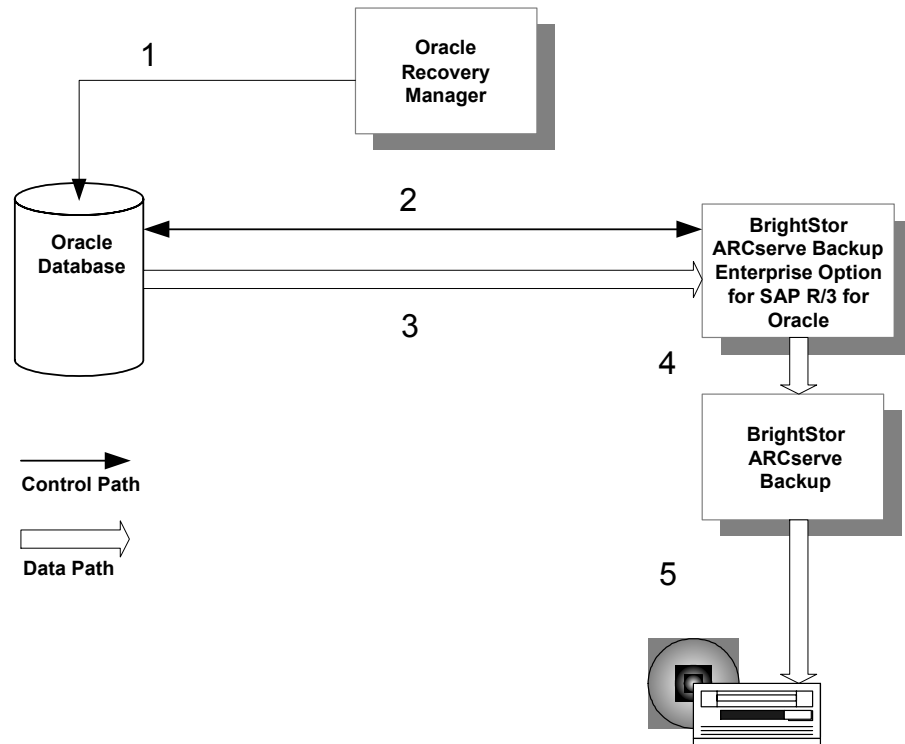

The following describes each step in the process, as shown in the diagram:

1. The user issues a backup request to the Oracle database from the Recovery Manager command line interface.
2. The database notifies the option of the backup request; the option requests transfer of backup data.
3. The database transfers the backup data to the option.
4. The option passes the backup data to BrightStor ARCserve Backup.
5. BrightStor ARCserve Backup saves the data to a storage medium.

How Recovery Manager Restores Data

The following diagram illustrates how you can process restore jobs initiated from Oracle Recovery Manager:

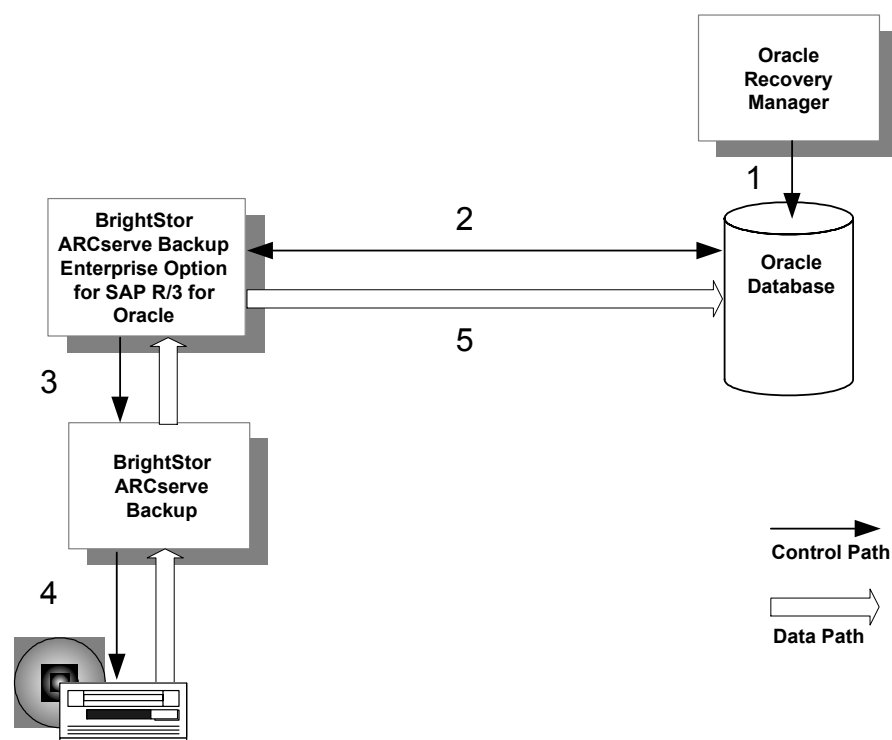

Note: When you restore with Recovery Manager, you can only restore with data that was backed up with Recovery Manager.

The following describes each step in the process, as shown in the diagram:

1. The user issues a restore request to the Oracle database from the Recovery Manager command line interface.
2. The database notifies the option of the restore request.
3. The option notifies BrightStor ARCserve Backup of the restore request.
4. BrightStor ARCserve Backup retrieves the data from a storage medium.
5. The option restores the Oracle database.

Chapter 2: Installing the Option

This chapter provides the information you need to install and configure the Enterprise Option for SAP R/3 for Oracle. The information in this chapter assumes you are familiar with the characteristics and requirements of the specified Windows operating systems in general, and with administrator responsibilities on those operating systems in particular.

Installation Prerequisites

Before installing the Enterprise Option for SAP R/3 for Oracle, verify the following prerequisites:

1. Your system meets the software requirements needed to install the option.
For a list of these requirements, see the readme files.
2. You have the following applications installed and running on the computer on which you want to install the option:
 - Oracle
 - BrightStor ARCserve Backup
 - SAP SAPDBA
 - Enterprise Module
 - Oracle Recovery Manager
3. You have administrative privileges or the proper authority to install software on the computers where you will be installing the option.

Hardware and Software Requirements

You can find Hardware and software requirements for the Enterprise Option for SAP R/3 for Oracle in the readme file for this release.

Option Installation

Install the Enterprise Option for SAP R/3 for Oracle on each database server you want BrightStor ARCserve Backup to manage.

For information about how to install the option, see the *Getting Started*.

Installation Considerations

Take the following considerations into account when you install the option:

1. When using the option, you must stop and start Oracle services after you install the option for the option to work with RMAN.
2. If you install the option on the same server as an existing installation of BrightStor ARCserve Backup, and you subsequently uninstall BrightStor ARCserve Backup, you must reinstall the option so that it can work with remote BrightStor ARCserve Backup.
3. Before installing the option, restore and recover any backups made with an earlier release of the option since the current release is not backward compatible.

Configure Oracle Server

Before you back up objects from an online Oracle database, do the following:

1. Check whether Oracle Server is operating in ARCHIVELOG mode.
For instructions, see Check ARCHIVELOG Mode.
2. Start ARCHIVELOG mode if it is not running.
For instructions, see Start ARCHIVELOG Mode.
3. Enable the database for automatic archiving.
For instructions, see Automatic Archiving.

Note: For Oracle 10g database, after you start archivelog mode, Oracle enables automatic archiving for you. For all other databases, you must follow all the steps in the Automatic Archiving section to enable automatic archiving.

ARCHIVELOG Mode

For the option to function correctly, ensure that the Oracle server application is operating in ARCHIVELOG mode. A database operating in ARCHIVELOG mode provides the following advantages:

- You can perform backups when the database is online.
- The archive logs and the last full backup (offline or online) can completely recover the database without losing any data, because all changes made in the database are stored in the log files.

ARCHIVELOG mode has the disadvantage of requiring additional disk space to store the archived log files. However, the option offers you the choice to purge the logs after they have been backed up at least twice.

For more information on implementing log purging, see the section Log File Purging in this chapter.

Check ARCHIVELOG mode

To check whether the ARCHIVELOG mode is on, follow these steps:

1. Log in as an Oracle user with SYSDBA equivalent privileges.
2. Enter the following command at the SVRMGR or SQLPLUS prompt:

```
ARCHIVE LOG LIST
```

This command displays the settings and status of the archive log files. The first line shows that ARCHIVELOG mode is enabled. If it is disabled, the database log mode is NOARCHIVELOG.

Start ARCHIVELOG Mode

To start ARCHIVELOG mode, follow these steps:

1. Shut down Oracle Server.
2. Depending on which version of Oracle you are running, execute the following statements:
 - At the SVRMGR prompt:

```
CONNECT INTERNAL
STARTUP MOUNT EXCLUSIVE
ALTER DATABASE ARCHIVELOG;
ALTER DATABASE OPEN;
ARCHIVE LOG START;
```

- At the SQLPLUS prompt:

```
CONNECT SYSTEM/SYSTEM_PASSWORD AS SYSDBA
STARTUP MOUNT EXCLUSIVE
ALTER DATABASE ARCHIVELOG;
ALTER DATABASE OPEN;
ARCHIVE LOG START;
```

Enable Automatic Archiving

Before you back up a tablespace from an online database, you must ensure that the database is enabled for automatic archiving. To do this, follow these steps:

1. Log in to the Oracle database server as an Oracle user with SYSDBA equivalent privileges.
2. Add the following lines in the INIT(SID).ORA file in your Oracle home directory:

```
LOG_ARCHIVE_START=TRUE
LOG_ARCHIVE_DEST=%RDBMS71_ARCHIVE%
LOG_ARCHIVE_FORMAT="ARC%S.%T"
```

Where:

- LOG_ARCHIVE_START enables automatic archiving
- LOG_ARCHIVE_DEST specifies the path to the archived redo log files
- LOG_ARCHIVE_FORMAT specifies the file name format for the archived redo log files. In this definition:
 - %S specifies the log sequence number
 - %T specifies the thread number.

For example, ARC%S.%T is acceptable.

For more information about setting the automatic archiving, see your *Oracle Server Administrator's Guide*.

Customize the Option to Support RMAN

Although the option has all the default values it needs to support RMAN, you can customize the way the agent works with RMAN by using the Backup Agent Configuration for Recovery Manager utility and changing any of the values. The path to this utility is:

Program Files\CA\BrightStor ARCserve Backup Agent for Oracle\RmanCfg.exe

To run the Configuration for Recovery Manager utility, follow these steps:

1. Start the Configuration for Recovery Manager utility.

The Backup Agent for Oracle Recovery Manager Configuration dialog opens, as shown in the following example:

The screenshot shows a dialog box titled "Backup Agent for Oracle Recovery Manager Configuration". It contains three sections:

- Local Machine Information:** Includes fields for "Local Machine User:", "Local Machine Password:", and "Confirm Local Machine Password:". There are three input boxes corresponding to these labels.
- BrightStor ARCserve Backup Server Information:** Includes fields for "BrightStor ARCserve Backup Server Domain:", "BrightStor ARCserve Backup Server:", "BrightStor ARCserve Backup Server User:", "BrightStor ARCserve Backup Server Password:", and "Confirm Backup Server Password:". There are five input boxes corresponding to these labels.
- Backup Destination:** Includes fields for "Group Name:" and "Media Name:". There are two input boxes corresponding to these labels.

On the right side of the dialog, there are three buttons: "OK", "Cancel", and "Help".

2. Under Local Machine Information, enter the local machine user name and the password for the local machine user. Reenter the password for the local machine user in the Confirm Local Machine Password field to confirm the password.
3. Under BrightStor ARCserve Backup Server Information, you can enter the:
 - BrightStor ARCserve Backup server domain name
 - BrightStor ARCserve Backup server name (this is the name of the machine on which BrightStor ARCserve Backup is installed)
 - BrightStor ARCserve Backup Server user name (this is the long name of the BrightStor ARCserve Backup server user who has BrightStor ARCserve Backup privileges)

- Password for the BrightStor ARCserve Backup server user
 - Password for the BrightStor ARCserve Backup server user again in the Confirm Backup Server Password field
4. Under Backup Destination enter, you can enter the:
- Tape group name for the backup destination
 - Media name for backups and restores
- Note:** You can enter an asterisk (*) for the tape group name and tape name if you want to use the default. The default is the current, active tape group and tape name.
5. Click OK.

SAPDBA Configuration

Before you can execute backup and restore operations using the option and SAPDBA, you must complete several configuration tasks. SAPDBA must be installed on the same computer as the option.

Configure Parameter File Settings

The util_par_file parameter file contains parameters for controlling the backup agent configuration module (also known as BACKINT) and BrightStor ARCserve Backup.

For a file sample, and definitions of file parameters, see the "Sample util_par_file and Parameter Definitions" appendix.

The parameter file name must be known to SAPDBA utilities for the proper operation of SAPDBA when it is working with BrightStor ARCserve Backup; the file is located under the \$ORACLE_HOME\database directory.

To modify the settings in the parameter file, follow these steps:

1. Start the Oracle Configuration Utility by clicking the Windows Start button and choosing Programs, Computer Associates, BrightStor ARCserve Backup Agents, Oracle Agent BACKINT Configuration.

The Backup Agent for R/3 Oracle Configuration window appears as shown in the following example:

The screenshot shows a dialog box titled "Backup Agent for R/3 Oracle Configuration" with a close button (X) in the top right corner. The dialog has three tabs: "Security Information", "Volume Backup", and "Volume Archive". The "Security Information" tab is active. It contains the following sections:

- Backup Server Type:** Two radio buttons are present: "Local Server" (unselected) and "Remote/Cluster Server" (selected).
- Backup Server:** Four text input fields labeled "Name:", "User:", "Password:", and "Confirm Password:".
- Local Server:** Four text input fields labeled "Name:", "User:", "Password:", and "Confirm Password:".
- Cluster Support:** A text area containing the following instructions:
If your SAP database is running on a Cluster server, please use virtual server name as your Local Server Name.
If your Backup Server is running on a Cluster server, please use virtual server name as your Backup Server Name.

At the bottom right of the dialog, there are two buttons: "OK" and "Cancel".

2. On the Security Information tab, modify the local or remote Backup Server Windows security information.
3. Click on the Volume Backup tab.

The Volume Backup tab appears as shown in the following example:

The screenshot shows a dialog box titled "Backup Agent for R/3 Oracle Configuration" with three tabs: "Security Information", "Volume Backup", and "Volume Archive". The "Volume Backup" tab is active. The dialog contains several sections:

- Use Media Pool:** A checkbox is unchecked. Below it are text boxes for "Media Pool Name:" and "Tape Name Prefix:" followed by a text box containing "_YYMMDD".
- Input Group Name/Tape Name for backup:** Two text boxes labeled "Group Name:" and "Tape Name:" both contain an asterisk (*).
- First Backup Option:** Two radio buttons are present: "Append" (selected) and "Overwrite".
- Automatic Tape Management:** A large empty text box is on the left. To its right are three buttons: "Add", "Delete", and "Scratch".
- Expire period:** A text box contains the number "0", followed by the text "Day(s)".

At the bottom right of the dialog are "OK" and "Cancel" buttons.

4. On the Volume Backup tab, modify media management information for BRBACKUP.

If you want to use media pool support, first create a media pool on your BrightStor ARCserve Backup server, and then check the Use Media Pool check box and enter the media pool information.

5. Click on the Volume Archive tab.

The Volume Archive tab appears as shown in the following example:

The screenshot shows a dialog box titled "Backup Agent for R/3 Oracle Configuration" with three tabs: "Security Information", "Volume Backup", and "Volume Archive". The "Volume Archive" tab is selected. The dialog contains the following fields and controls:

- Input Group Name/Tape Name for backup:**
 - Group Name:
 - Tape Name:
- First Backup Option:**
 - Append
 - Overwrite
- Automatic Tape Management:**
 - A large empty rectangular area for listing tape management items.
 - Buttons: Add, Delete, Scratch.
 - Expire period: Day(s)

At the bottom right, there are "OK" and "Cancel" buttons.

6. On the Volume Archive tab, modify media management information for BRARCHIVE.

To use media pool support, create a media pool on BrightStor ARCserve Backup server, check the Use Media Pool check box, and enter the media pool information.

Configure the init<SID>.sap File

The init<SID>.sap configuration file for SAPDBA is part of the SAP environment. It contains all backup and archive parameters. To configure this file for use with BrightStor ARCserve Backup, set these parameters as follows:

1. Open the file with Notepad or a similar text editor.
2. Edit the file as required:
 - For an offline backup, set backup_dev_type = util_file
 - For an online backup, set backup_dev_type = util_file_online
 - Set util_par_file= *parameter_file_name*
3. Save the file.

With these changes, SAPDBA now calls the BACKINT interface instead of CPIO and assumes that BACKINT is located in the directory:

```
c:\usr\sap\SID\SYS\exe\run
```

You can also change the settings for the above parameters on the SAPDBA Backup menu.

Create ACLs (Access Control Lists)

Access Control Lists allow you to identify the specific remote BrightStor ARCserve Backup servers permitted to back up the Oracle database. If the BrightStor ARCserve Backup Client Agent for Windows is installed, ACLs can be created and edited from the Agent Admin interface.

See the BrightStor ARCserve Backup Client Agent for Windows online help for more information.

If the BrightStor ARCserve Backup Client Agent for Windows is not installed, ACLs can be created manually by adding new registry values. To create an ACL manually, follow these steps:

1. On the Windows Start menu, click Run.

The Run dialog appears.

2. In the Open field, enter:

```
regedit
```

The Registry Editor window appears.

3. In the tree view pane, expand the following folders to view this registry path:

```
Software\ComputerAssociates\BrightStor ARCserve  
Backup\UniversalClientAgent\ACL
```
4. Double-click the appropriate registry entry and make the following entries in the Edit String dialog:
 - **ServerList** (REG_MULTI_SZ): BrightStor ARCserve Backup server names. Enter one server name per line.
 - **type** (REG_DWORD): Enter **one** of the following values:
 - 0**: (default) All BrightStor ARCserve Backup servers are permitted to back up the database.
 - 1**: only BrightStor ARCserve Backup servers on the list are permitted to back up the database.
 - 2**: only BrightStor ARCserve Backup servers NOT on the list are permitted to back up the database.
5. Click OK on the Edit String dialog after you complete each entry.
6. Close the Registry Editor.

Log File Purging

The option supports the purging of the archived redo log files. Log file purging is enabled by default.

Note: You can purge achieved redo log files only after they have been backed up at least twice.

Disable Log File Purging

Important! *Be very careful when making changes to the Windows Registry. Improper entries can affect the functionality of the product and the operation of your computer.*

To disable log file purging, follow these steps:

1. On the Windows Start menu, click Run.
The Run dialog appears.
2. In the Open field, enter:

```
regedit
```

The Registry Editor window appears.

3. On the Services dialog, locate the CA BrightStor ARCserve Backup Agent RPC Server.

The Services dialog displays the current status of the service.

4. To start or stop the service, select the CA BrightStor ARCserve Backup Agent RPC Server and choose Start or Stop from the pop-up menu.

Remove the Option

To remove the option from your computer, follow these steps:

1. Open the Windows Control Panel.
2. Double-click the Add or Remove Programs icon.
3. Select CA BrightStor ARCserve Backup Enterprise Option for SAP R/3 for Oracle.
4. Click Remove.

The Add or Remove Programs dialog opens.

5. Click Yes.

Chapter 3: Using the Option

The Oracle server application is organized into databases. Each Oracle database contains the following types of objects:

- **Tablespaces**—These objects contain data and may consist of multiple data files.
- **Online redo log files**—These objects contain records of transactions applied to the tablespaces.
- **Control files**—These objects describe the structure of the database, including the tablespaces. There can be more than one control file for the database.

The BrightStor ARCserve Backup Enterprise Option for SAP R/3 for Oracle lets you back up a complete database or individual objects within the database.

Online Redo Log Files

Oracle Server uses online redo log files to record all entries to the Oracle tablespaces. However, the Option for SAP R/3 for Oracle requires archived online redo log files to function properly. For Oracle to create archived redo log files, you must set Oracle to operate in ARCHIVELOG mode. Also, for the agent to back up and restore properly, you must set Oracle to automatically archive online redo log files.

Note: For information about setting Oracle so that it operates in ARCHIVELOG mode and automatically archives online redo log files, see Enable Automatic Archiving in the “Installing the Option” chapter.

Multiple Databases

If your Oracle configuration has more than one database you can:

- View and log in to the databases
- Back up multiple databases simultaneously
- Quickly find the database objects that you want to back up

Configure a Backup Session for Multiple Databases

To configure a backup session so you can log in to and view the databases you specified during installation on an Oracle configuration containing multiple databases, follow these steps:

1. Ensure that all the BrightStor ARCserve Backup and agent-related services are running.
2. Open the Backup Manager window.
3. In the Backup Manager window, expand the server on which the Oracle server is installed. All the databases you configured on the Oracle server appear.
4. Right-click the database you want to log in to. A pop-up menu opens.
5. Select Security.
6. Enter the user name and password you specified during configuration. Depending on which version of Oracle you are using, this user name should be INTERNAL or SYSTEM, or have SYSDBA equivalent privileges.
7. Click OK. Expand the selected database to view objects and to select the objects to back up.

Database Backup

Using the option you can back up complete Oracle databases and individual Oracle database objects, such as tablespaces, archived redo log files, and control files (each tablespace in a database is backed up as a separate session), parameter files and the recovery area.

You should back up all of the objects in a database immediately after you create the database and maintain a regular backup schedule to ensure smooth recovery in case of database or media failure. BrightStor ARCserve Backup allows you to set and maintain a schedule of automatic backups.

For each online tablespace marked for backup, the option instructs Oracle to begin backup mode operation for the tablespace. The option retrieves the tablespace and passes it directly to BrightStor ARCserve Backup, which sends it to a backup media drive. When the backup is complete, the option instructs Oracle to end the backup mode operation.

Back Up Online Databases with BrightStor ARCserve Backup

If you back up an Oracle database using the BrightStor ARCserve Backup interface, you must restore it using the BrightStor ARCserve Backup interface. Similarly, if you back up an Oracle database using Recovery Manager, you must restore it using Recovery Manager.

To back up an Oracle database, follow these steps:

1. Ensure that the Oracle server application is running.
2. Start BrightStor ARCserve Backup and the option.
3. In the Source tab on the Backup Manager, select the databases that you want to back up. You can select any number of databases in any combination, or all of them together.

Important! *Make sure all of the tablespaces on the database are online before backing up the Oracle database.*

When you back up multiple databases, you are prompted to enter the user name and password for each database. All options that apply to backing up a single online database can be applied to backing up multiple online databases.

Databases are backed up sequentially on the media.

BrightStor ARCserve Backup saves each tablespace (or database object) as a session. Therefore, the total number of sessions equals the total number of tablespaces, plus two additional sessions: one for archive logs for each Oracle database, and the other for the control file.

Note: If you select ~ARCHIVE LOG, the option backs up all of the archived log files under the archive log directory. If you select the control file, you must select only the control file or select the control file and **all** other tablespaces; otherwise the backup job will fail.

4. Click the Destination tab to select a backup destination.
5. Click the Schedule tab. Choose Custom Schedule or Use Rotation Scheme, and select the scheduling options you want to apply to the job.
6. Click Start to submit the job.

The Security and Agent Information dialog appears as shown in the following example:

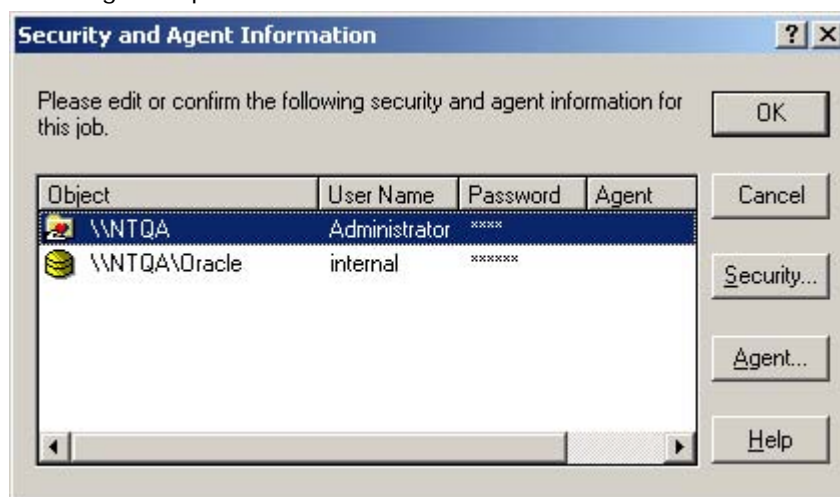

You must provide security information. In this dialog, the column and button labeled "Agent" refer to the Client Agent, not the Enterprise Option for SAP R/3 for Oracle. You can enter client agent information at this time.

See the *BrightStor ARCserve Backup Client Agents Guide* for more information about Client Agents.

7. To enter or change the user name and password for the Oracle server application, select the Oracle object and click Security.
8. Click OK.

The Submit Job dialog opens.

9. Click OK.

The job is submitted to the queue and can be monitored from the Job Queue Manager.

For more information about customizing your backup, see the *Administrator Guide*.

Back Up Offline Databases with BrightStor ARCserve Backup

You can back up an offline Oracle database. In this case, BrightStor ARCserve Backup treats the Oracle database files the same way as it treats any other system files.

To back up an offline Oracle database, follow these steps:

1. Start BrightStor ARCserve Backup and open the Backup Manager.
2. Expand the directories.
3. Select all of the individual data files that make up the Oracle database or select the directories that contain the targeted files.

Note: Oracle database files can be located anywhere (on any hard disk or in any directory). If you are performing a full offline backup of all your Oracle databases, make sure you select all the Oracle database files located on different drives.

4. Click the Destination tab to select a backup destination.
5. Click the Schedule tab, and select the scheduling options you want to apply to the job.
6. Click Start to submit the job.

The Security and Agent Information dialog appears as shown in the following example:



You must provide security information. In this dialog, the column and button labeled "Agent" refer to the Client Agent, not the BrightStor ARCserve Backup Enterprise Option for SAP R/3 for Oracle. You can enter client agent information at this time.

See the *Client Agents Guide* for more information about Client Agents.

7. To enter or change the user name and password for the Oracle server application, select the Oracle object and click Security.

8. Click OK.

The Submit Job dialog opens.

9. Click OK.

The job is submitted to the queue and can be monitored from the Job Queue Manager.

Back Up in an Oracle Fail Safe Environment with BrightStor ARCserve Backup

To back up data in an Oracle Fail Safe environment with BrightStor ARCserve Backup, follow these steps:

1. Make sure that Oracle Fail Safe group is running in your Microsoft Cluster environment.
2. Start BrightStor ARCserve Backup and start the Backup Manager.
3. On the Source tab, browse the Microsoft Network or the preferred shares to locate the Oracle Fail Safe groups.
4. Select the appropriate Oracle server from its Oracle Fail Safe group.
5. Double-click the Oracle server to display and select tablespaces for this instance.
6. Click the Destination tab and select a backup destination.
7. Click the Schedule tab and select the scheduling options you want to assign to this backup job.
8. Click Start.
9. Enter the user name and password of the Oracle Fail Safe group. To enter or change security information for the Oracle Fail Safe group, select the Oracle Fail Safe group and click Security.
10. Click OK to submit the job.

Note: Although you can browse all Oracle databases from any Oracle Fail Safe group, you can only achieve a successful backup by selecting the Oracle databases from its corresponding Oracle Fail Safe group. If the node on which the Oracle Fail Safe group is currently running enters failover mode during a backup job, the back up job is incomplete and must be resubmitted.

Oracle Recovery Manager Backup

Before performing any backup or restore operations with RMAN, run the Oracle Backup Agent RMAN Configuration utility.

Before a Recovery Manager backup job is started, you must have BrightStor ARCserve Backup running. If the BrightStor ARCserve Backup server is on a remote computer, the BrightStor ARCserve Backup Agent RPC Server also must be running on the agent computer. To check the status of the CA BrightStor ARCserve Backup Agent RPC Server service, open the Windows Services utility. For example, on a Windows 2000 computer, follow these steps:

1. Click the Windows Start button.
2. Choose Settings.
3. Click Control Panel.
4. Double-click Administrative Tools.
5. Double-click Services.

The media that will contain the backup file must be ready in the media drive connected to the BrightStor ARCserve Backup server. If not, BrightStor ARCserve Backup displays a message asking you to mount the correct media.

Note: If you back up the Oracle database using the BrightStor ARCserve Backup interface, you must restore it using the BrightStor ARCserve Backup interface. Similarly, if you back up the Oracle database using RMAN, you must restore it using RMAN.

Connect to Recovery Manager and Back Up

To connect to Recovery Manager at the command line and back up database objects, follow these steps:

1. Log in on the computer on which the option is running. Use a user ID with administrator privileges.
2. From the Windows Start button menu, start a command prompt session.

3. Enter the following command:

```
rman nocatalog
```

The Recovery Manager starts in the command prompt window, and the command line prompt becomes RMAN>.

Enter the following commands to back up the database instance named test.

Note: In the following command, the *@instance_name* parameter is required only if you have multiple database instances.

```
connect target system/manager@test
RMAN> run {
```

The program provides numbered prompts for each of the following entries:

```
2> allocate channel dev1 type 'sbt_tape';
3> backup database format 'as_%s_%t';
4> release channel dev1;
5> }
```

The backup begins. The progress of the backup is displayed in the command prompt session. When the backup is complete, you can continue to work with RMAN, or you can exit the command prompt session.

The following is a sample session for connecting to Recovery Manager:

```
Microsoft Windows 2000 [Version 5.00.2195]
(C) Copyright 1985-2000 Microsoft Corp.

C:\>rman nocatalog

Recovery Manager: Release 9.0.1.1.1 - Production
(c) Copyright 2001 Oracle Corporation. All rights reserved.

RMAN> connect target system/manager

connected to target database: TEST (DBID=1742829507)
using target database controlfile instead of recovery catalog

RMAN> run {
2> allocate channel dev1 type 'sbt_tape' ;
3> backup database format 'as_%s_%t' ;
4> release channel dev1 ;
5> }

allocated channel: dev1
channel dev1: sid=12 devtype=SBT_TAPE
channel dev1: MMS Version 0.0.0.0

Starting backup at 02-NOV-01
channel dev1: starting full datafile backupset
channel dev1: specifying datafile(s) in backupset
including current controlfile in backupset
input datafile fno=00001 name=G:\ORACLE\ORADATA\TEST\SYSTEM01.DBF
input datafile fno=00002 name=G:\ORACLE\ORADATA\TEST\UNDOTBS01.DBF
input datafile fno=00005 name=G:\ORACLE\ORADATA\TEST\EXAMPLE01.DBF
input datafile fno=00006 name=G:\ORACLE\ORADATA\TEST\INDX01.DBF
input datafile fno=00008 name=G:\ORACLE\ORADATA\TEST\USERS01.DBF
input datafile fno=00003 name=G:\ORACLE\ORADATA\TEST\CMLITE01.DBF
input datafile fno=00004 name=G:\ORACLE\ORADATA\TEST\DRSYS01.DBF
input datafile fno=00007 name=G:\ORACLE\ORADATA\TEST\TOOLS01.DBF
channel dev1: starting piece 1 at 02-NOV-01
channel dev1: finished piece 1 at 02-NOV-01
piece handle=as_1_444743078 comment=API Version 1.1,MMS Version 0.0.0.0
channel dev1: backup set complete, elapsed time: 00:05:48
Finished backup at 02-NOV-01

released channel: dev1
```

After a backup job is done, you can check the job status in the BrightStor ARCserve Backup activity log, or by viewing the Database Manager.

Database Restore with the Option

This section explains how to restore database objects such as tablespaces, archive log files, and control files. You can recover an individual tablespace or data file (a tablespace is composed of one or more data files).

Note: If the Oracle database is online, you can restore an individual tablespace or data file if the tablespace is offline. If the database is offline, you must recover the entire database in order to recover a tablespace or data file.

The option lets you restore the control files when you restore the database. However, BrightStor ARCserve Backup backs up the control file only if you select it as a backup source on the Source tab of the Backup Manager. To back up the control file, either select all tablespaces (database objects) **and** the control file or select **only** the control file.

Note: If the current control files and the online redo log files are not damaged, it may not be necessary to overwrite the control files. Keeping the current control files makes the recovery a simpler task.

See the Oracle Server Administrator's Guide for more information about restoring a control file.

Note: The backup sessions you select to restore must have been successfully completed backup jobs. You should not attempt to restore a cancelled or failed backup job.

Restore a Database with BrightStor ARCserve Backup

To restore a database, tablespaces, data files, or control files, follow these steps:

1. Shut down the Oracle server application. If you prefer not to shut down the Oracle server application, and you are restoring only a tablespace or data file, take the tablespace offline.
2. Open the BrightStor ARCserve Backup Restore Manager.
3. In the Restore Manager Restore by Tree view, expand the Oracle server application and select the database or the objects you want to restore.

Note: You do not need to select a destination—the Oracle database objects are automatically restored to their original locations.

4. Click the Schedule tab and select the scheduling options you want to apply to this job.
5. Click Start to submit the job.

Restore Suggestions

The following are some suggestions for completing a successful restore:

- To restore the control file, select the ~CONTROLFILE icon. The restore process saves the control file as CONTROL.SIDNAME in the option home directory. You can then use the MS-DOS copy command to copy the restored control file to the appropriate directory.

Important! *You must overwrite all default database control files with the restored one. Use this format: copy CONTROL.ORCL path\ct11ORCL.ORA*

For example:

```
copy CONTROL.ORCL <path>\ct11ORCL.ORA
```

For more information on restoring a control file, see the Oracle Server Administrator's Guide.

- To restore either the system tablespace or a tablespace containing rollback segments, you must shut down the database and perform a full database restore.
- To restore an older session of a tablespace, click Version History and select the session you want to restore. After you have selected, click OK and finish the rest of the restore procedure.
- If your current control files and the archived redo log files are not damaged, you may not want to recover the backed up control files and overwrite the current control files. Keeping the current control files allows you to restore your database to the latest usable version before a crash has occurred.

Restore to an Alternate Server

To restore to a server other than the server from which the backup was created, follow these steps:

1. Select the server and the file directory you want to restore to.

Note: This server must be running one of the Windows operating systems required by the option. For a list of operating systems, see the Readme file for this release

2. Click the Schedule tab and select the scheduling options you want to apply to this job.
3. Click Start. The Session User Name and Password dialog appears as shown in the following example:

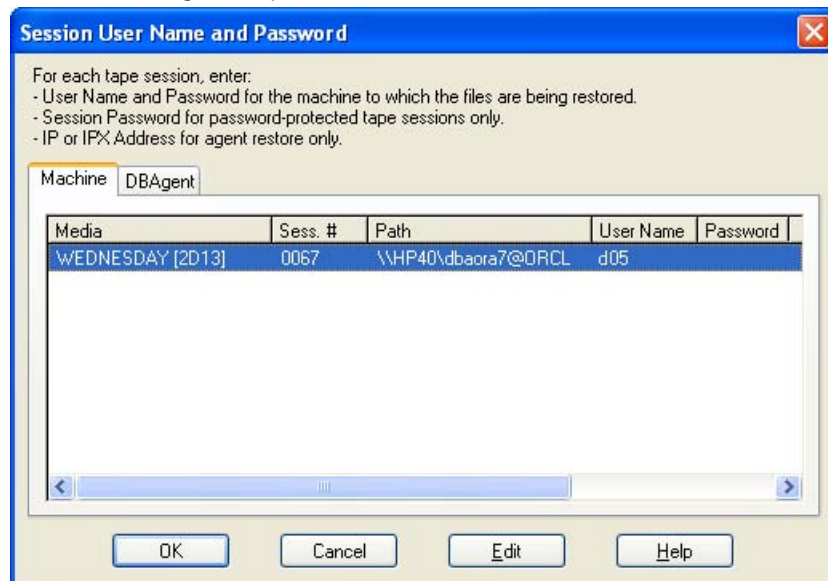

4. To enter or change the user name and password (and the session password) for the computer on which the source Oracle application server is running, select the session and click Edit.

5. Click the DBAgent tab.

The DBAgent tab appears as shown in the following example:

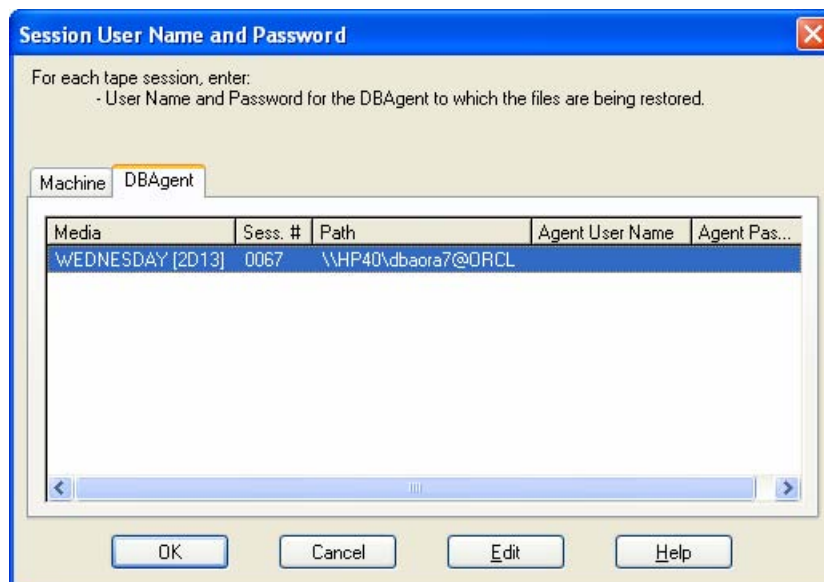

6. Enter the user name and password:
 - For Oracle 7.3 and Oracle 8.0, 8.1, enter the user name INTERNAL.
 - For Oracle 9.0 or 9.2, enter the user name SYSTEM.
7. For any version, the user name can also be any account with SYSDBA equivalent privileges.
8. Click OK.

The job is submitted to the queue and can be monitored from the Job Queue Manager.

When the job is completed, the database objects are restored to the selected server. It may be necessary to manually move the Oracle files into the proper locations after the restore is complete.

If the Oracle database has multiple archived log directories and archived log files that have been restored, to synchronize them, you must copy the restored files to the archived log directories.

See the following sections for information about recovering the Oracle database. For more information about submitting a restore job, see the *Administrator Guide*.

Restore the System Tablespace

To restore the system tablespace, follow these steps:

1. Shut down the database.
2. Open the Restore Manager.
3. On the Source tab, select the Restore by Tree view and select the tablespace you want to restore.

Note: The Oracle database objects are automatically restored to their original locations. You do not need to select a destination.

4. Click the Schedule tab and select the scheduling options you want to apply to this job.
5. Click Start.

The Session User Name and Password dialog opens.

6. To enter or change the user name and password (and the session password) for the machine on which the Oracle server is running, select the session and click Edit.
7. Enter the user name and password:
 - For Oracle 7.3 and Oracle 8.0, 8.1, enter the user name INTERNAL.
 - For Oracle 9.0 or 9.2, enter the user name SYSTEM.
 - For any version, the user name can also be any account with SYSDBA equivalent privileges.
8. Click OK.

The job is submitted to the queue and can be monitored from the Job Queue Manager.

Restore Databases Backed Up Offline

To restore an offline backup, shut down the Oracle server application, and restore the Oracle files using BrightStor ARCserve Backup. You must select all of the files that make up the database; these files may be located on different physical drives or volumes.

Note: The backup you want to restore from must be a backup that was created with the BrightStor ARCserve Backup Manager. You cannot use the BrightStor ARCserve Backup interface to restore from a backup that was created with Recovery Manager.

Restore in an Oracle Fail Safe Environment

To restore in an Oracle Fail Safe environment with BrightStor ARCserve Backup, follow these steps:

1. Open the BrightStor ARCserve Backup Restore Manager.
2. On the Source tab, select the Restore by Tree or Restore by Session option. Select the source you want to restore and a backup version or sessions for the tablespace.
3. Click the Destination tab and select a destination. You can restore to either the original location or server or an alternate location or server.
4. If you are restoring to the original location, ensure that the **Restore files to the original locations(s)** option is selected.
5. If you are restoring to a specific node in the Oracle Fail Safe group, clear the **Restore files to the original locations** option and select the Oracle database from the node to which you want to restore.

In the following example the domain is ORACLE_DOMAIN, the node is ORACLE_NODE, and the network name for the Oracle instance (SID) is OFS1:

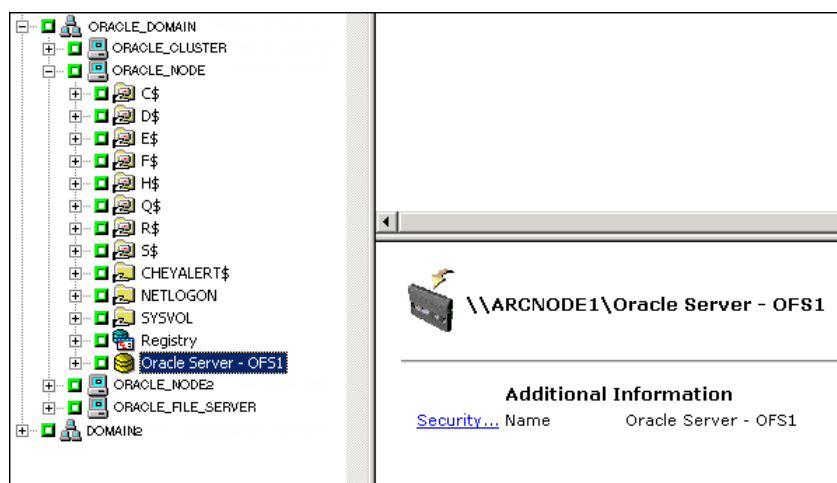

6. Click Start. The Session User Name and Password dialog opens.
7. Verify or change the user name and password for the Oracle Fail Safe group tablespace and the Microsoft Cluster Server. To change the user name and password for the Microsoft Cluster Server, select the session and click Edit. If a session password was assigned to this session, enter the session password. Click OK. The Job Scheduler dialog opens.
8. Schedule the job to run now or at a later time, and then click OK. The job is submitted to the queue and can be monitored from the Job Queue Manager.

Oracle Recovery Manager Restore

Before performing any backup or restore operations with Oracle Recovery Manager (RMAN), run the Oracle Backup Option RMAN Configuration utility. See the section Oracle Recovery Manager Backup in this chapter for more information.

Before you start a Recovery Manager restore job, you must have BrightStor ARCserve Backup running. If the BrightStor ARCserve Backup server is on a remote machine, the CA BrightStor ARCserve Backup Agent RPC Server service also must be running on the option machine. To check the status of the Agent RPC Server service, see the section Check the Status of the Option in the Installing the Option chapter of this guide.

The media containing the backup file that you are restoring from must be ready in the media drive connected to the BrightStor ARCserve Backup server. If not, BrightStor ARCserve Backup displays a message asking you to mount the correct media.

Note: The backup you want to restore from must be a backup that was created with Recovery Manager. You cannot use Recovery Manager to restore from a backup that was created with the BrightStor ARCserve Backup interface.

Connect to Recovery Manager and Restore

To connect to Recovery Manager at the command line and restore database objects, follow these steps:

1. Log in on the computer on which the option is running. Use a user ID with administrator privileges.
2. From the Windows Start button menu, start a command prompt session.
3. Enter the following command:

```
rman nocatalog
```

The Recovery Manager starts in the command prompt window, and the command line prompt becomes RMAN>.

4. Enter the following commands to back up the database instance named test.

Note: In the following command, the *@instance_name* parameter is required only if you have multiple database instances.

```
connect target system/manager@test  
RMAN> run {
```

The program provides numbered prompts for each of the following entries:

```
2> allocate channel dev1 type 'sbt_tape';  
3> restore database;  
4> release channel dev1;  
5> }
```

The restore begins and the progress of the restore is displayed in the command prompt session. When the restore is complete, you can continue to work with RMAN, or you can exit the command prompt session.

The following is a sample session for connecting to Recovery Manager: The first portion of the session is a backup session, and the second portion of the session illustrates a restore session. In this case a tablespace is being restored.

```

Starting backup at 02-NOV-01
channel dev1: starting full datafile backupset
channel dev1: specifying datafile(s) in backupset
including current controlfile in backupset
input datafile fno=00001 name=G:\ORACLE\ORADATA\TEST\SYSTEM01.DBF
input datafile fno=00002 name=G:\ORACLE\ORADATA\TEST\UNDOTBS01.DBF
input datafile fno=00005 name=G:\ORACLE\ORADATA\TEST\EXAMPLE01.DBF
input datafile fno=00006 name=G:\ORACLE\ORADATA\TEST\INDEX01.DBF
input datafile fno=00008 name=G:\ORACLE\ORADATA\TEST\USERS01.DBF
input datafile fno=00003 name=G:\ORACLE\ORADATA\TEST\CWMLITE01.DBF
input datafile fno=00004 name=G:\ORACLE\ORADATA\TEST\DRSYS01.DBF
input datafile fno=00007 name=G:\ORACLE\ORADATA\TEST\TOOLS01.DBF
channel dev1: starting piece 1 at 02-NOV-01
channel dev1: finished piece 1 at 02-NOV-01
piece handle=as_1_444743078 comment=API Version 1.1.MMS Version 0.0.0.0
channel dev1: backup set complete, elapsed time: 00:05:48
Finished backup at 02-NOV-01

released channel: dev1

RMAN> run {
2> allocate channel dev1 type 'sbt_tape' ;
3> restore tablespace users ;
4> release channel dev1 ;
5> }

allocated channel: dev1
channel dev1: sid=12 devtype=SBT_TAPE
channel dev1: MMS Version 0.0.0.0

Starting restore at 02-NOV-01

channel dev1: starting datafile backupset restore
channel dev1: specifying datafile(s) to restore from backup set
restoring datafile 00008 to G:\ORACLE\ORADATA\TEST\USERS01.DBF
channel dev1: restored backup piece 1
piece handle=as_1_444743078 tag=null parans=NULL
channel dev1: restore complete
Finished restore at 02-NOV-01

released channel: dev1

RMAN>

```

After a restore job is done, you can check the job status in the BrightStor ARCserve Backup activity log, or from the Database Manager.

Restore to a Particular Point in Time

To restore a database or tablespace to a particular point in time, follow the procedures to restore a database or a tablespace and the associated archive log files. For more information, see the section Restore a Database with BrightStor ARCserve Backup in this chapter.

See your *System Administrator Guide* for more information about restoring or recovering the database or tablespace to a particular point in time.

Archive Logs Restore

If both the control files and archive log files have been lost or corrupted, you must select both ~CONTROLFILE and ~ARCHIVE LOG icons as source sessions to be restored.

For instructions, see the sections Recover Tablespaces or Data Files and Recover Complete Databases in this chapter.

Database Recovery

After you restore the database objects to the server, you must recover the database. You can recover the database or database objects using one of the following methods:

- Recover a complete database
- Recover a complete database with a backed up control file
- Recover a tablespace or data file
- Recover from an offline full backup

These methods are described in the following sections.

Recover Complete Databases

After you have completed a successful restore of a database, you must use the Oracle Server Manager Console to recover the database. To recover a database with current control files, follow these steps:

1. Start the database instance, and mount the database without opening it:

- At the SVRMGR prompt enter:

```
CONNECT INTERNAL
STARTUP MOUNT
```

- At the SQLPLUS prompt enter:

```
CONNECT SYSTEM/SYSTEM_PASSWORD AS SYSDBA;
STARTUP MOUNT
```

Note: You may use a different Oracle SYSDBA instead of INTERNAL or SYSTEM if the SYSDBA has the proper backup and restore privileges.

2. Begin the database recovery process by entering the following command at the SVRMGR or SQLPLUS prompt:

```
RECOVER DATABASE
```

3. Oracle checks for the archive redo log files it needs to apply and prompts for the names of these archive redo log files in chronological order.

For example, if Oracle needs the name of the archive redo log file with a sequence number of 49, the following message displays:

```
ORA-00279: Change 10727 generated at 09/15/95 16:33:17 needed for
thread 1
ORA-00289: Suggestion : D:\ORANT\saparch\ARC00049.001
ORA-00200: Change 10727 for thread 1 is in sequence #49
Specify log<<RET>=suggested : filename : AUTO : FROM logsource : CANCEL
```

4. If you have all of the necessary archived log files, enter AUTO to apply the files. Oracle applies the log data to restore the datafiles. After Oracle finishes applying the redo log file, the following message is displayed:

```
Applying suggested logfile...
Log applied.
```

After each log is applied, Oracle continues to apply the next redo log file until the recovery is complete.

Note: If Oracle returns an error indicating that the log file cannot be opened, the log file may not be available. At the prompt, enter CANCEL. This command stops the complete media recovery.

For more information about recovery and archive redo log files, see the Oracle Server Administrator's Guide.

5. Open the database by entering the following command:

```
ALTER DATABASE OPEN;
```

The database is now recovered to the last log file available.

Note: For the most reliable database objects recovery, you should back up archived log files using the `~ARCHIVELOG` object. For more information on database recovery, see the *Oracle Server Administrator's Guide*.

Recover Complete Databases with Backed Up Control Files

If a control file has been lost or corrupted, you must first shut down the database and recover the control files prior to recovering the database. You must also use the Oracle Server Manager or Oracle SQL*Plus to perform the recovery procedure.

To recover lost or corrupted control files, follow these steps:

1. Shut down the database by entering the following command at either the SVRMGR or SQLPLUS prompt:

```
SHUTDOWN;
```

2. Go to the Oracle home directory. Copy the control file from the option home directory to its original location and file name.
3. Rename the restored control files back to the original control file names. The restore process will have restored the original control file. You must rename the restored version of the control file back to the original file name.

To recover the complete database, follow these steps:

1. To start and mount the database and recover the database:

- At the SVRMGR prompt, enter the following commands:

```
CONNECT INTERNAL;  
STARTUP MOUNT;  
RECOVER DATABASE USING BACKUP CONTROLFILE UNTIL CANCEL;
```

- At the SQLPLUS prompt, enter the following commands:

```
CONNECT SYSTEM/SYSTEM_PASSWORD AS SYSDBA;  
STARTUP MOUNT;  
RECOVER DATABASE USING BACKUP CONTROLFILE UNTIL CANCEL;
```

2. You are prompted to enter the log file names. Oracle first looks for the archive log files, and automatically supplies the correct names for the files that exist. If it cannot find the necessary archive log files, you must manually apply the online redo logs.

You must supply the full path and file name for the online redo logs. If you enter an incorrect log, re-enter the command:

```
RECOVER DATABASE USING BACKUP CONTROLFILE UNTIL CANCEL;
```

Supply the correct online redo log file name at the prompt. Continue this procedure until all logs have been successfully applied.

3. To bring the database back online and reset the logs, enter the following command at the SVRMGR or SQLPLUS prompt:

```
ALTER DATABASE OPEN RESETLOGS;
```

4. In the directories where the archived redo logs are stored, delete all of the log files.
5. To bring any tablespaces that are still offline back online, enter the following command at the SVRMGR or SQLPLUS prompt:

```
ALTER TABLESPACE TABLESPACE_NAME ONLINE;
```

Recover Tablespaces or Data Files

If the Oracle database is open, you can restore and recover a tablespace by first placing the tablespace offline. To recover a tablespace or data file, follow these steps:

1. Take the tablespace offline by entering the following command at the SVRMGR or SQLPLUS prompt:

```
ALTER TABLESPACE "tablespace_name" OFFLINE;
```

Note: The Oracle server may take the damaged tablespace offline automatically. If that is the case, go to Step 2.

2. Restore the tablespace or data file using BrightStor ARCserve Backup and the BrightStor ARCserve Backup Agent for Oracle if you have not done so.
3. Begin the database recovery process:

- If you are recovering a **tablespace**, enter the following command at the SVRMGR or SQLPLUS prompt:

```
RECOVER TABLESPACE "tablespace_name";
```

- If you are recovering a **data file**, enter the following command at the SVRMGR or SQLPLUS prompt:

```
RECOVER DATAFILE 'path';
```

For example,

```
RECOVER DATAFILE 'T\Oracle\Oradata\Orc1\Backup.Ora';
```

4. Oracle checks for the archive redo log files it needs to apply and prompts for the names of these archive redo log files in chronological order.

For example, when Oracle needs the name of the archive redo log file with a sequence number of 49, it displays the following message:

```
ORA-00279: Change 10727 generated at 09/15/95 16:33:17 needed for
thread 1
ORA-00289: Suggestion : D:\ORANT\saparch\ARC00049.001
ORA-00200: Change 10727 for thread 1 is in sequence #49
Specify log<<RET>=suggested : filename : AUTO : FROM logsource : CANCEL
```

5. If you have all the necessary archived log files, enter AUTO to apply the files. Oracle applies the log data to restore the datafiles. After Oracle finishes applying the redo log file, it displays the following message:

```
Applying suggested logfile...
Log applied.
```

After each log is applied, Oracle continues to apply the next redo log file until the recovery is complete.

Note: If Oracle returns an error indicating that the log file cannot be opened, the log file may not be available. At the prompt, enter CANCEL. This command stops the complete media recovery. In this case, perform the incomplete media recovery to restore the tablespace again. After all the log files are applied, database recovery is complete. For more information about incomplete media recovery, see the Oracle Server Administrator's Guide.

6. Open the database by entering the following command:

```
ALTER TABLESPACE "tablespace_name" ONLINE;
```

The tablespace is now recovered to the last available log file.

Note: For the most reliable database objects recovery, you should back up archived log files using the ~ARCHIVELOG object. For more information on database recovery, see the Oracle Server Administrator's Guide.

Recover From Offline Full Backups

You can recover an Oracle database from an offline full backup. To recover from an offline backup, shut down the Oracle server application and restore the Oracle files using the BrightStor ARCserve Backup Restore Manager. You must select all of the files that make up the database.

Note: The backup you want to restore from must be a backup that was created with Backup Manager. You cannot use Restore Manager to restore from a backup that was created with the Recovery Manager interface.

Backup and Restore Limitations

The following are limitations for backups and restores initiated with the option:

Function or Feature	Limitation
Backing up online redo logs	The online redo logs are exclusively locked by Oracle while the Oracle database is online. Perform an offline backup if necessary.

Function or Feature	Limitation
Restoring the system tablespace or tablespaces with rollback segments	To restore either the system tablespace or a tablespace containing rollback segments, you must first shut down the database and perform a full database restore. For more information, see the section Restore the System Tablespace in this chapter.
Backup and restore	If you back up the Oracle database using the BrightStor ARCserve Backup interface, you must restore it using the BrightStor ARCserve Backup interface. Similarly, if you back up the Oracle database using RMAN, you must restore it using RMAN.

Chapter 4: Using the Option with Oracle SAPDBA

You can perform operations such as backups, restores, or inquiries by using the SAPDBA menu or by entering SAPDBA commands at the command line. This chapter provides information about using the SAPDBA menu to back up and restore data.

For information about using the command line, see the SAP R/3 for Oracle documentation.

SAPDBA

By using the SAPDBA menu, you can perform various database administration functions, including:

- Backing up, restoring, and recovering data
- Starting up and shutting down databases
- Extending tablespaces
- Monitoring and analyzing space on the database
- Reorganizing databases
- Recovering databases

SAPDBA uses BRBACKUP, BRARCHIVE, and BRRESTORE modules (which are embedded in the menu structure of SAPDBA) to integrate with the database backup, restore, and inquiry functions.

SAPDBA evaluates logs to decide if data can be recovered using the selected backups. SAPDBA evaluates the selected backup method and determines if it will prevent recovery between the time of the backup and the selected recovery end time (point in time). If SAPDBA cannot perform a recovery, it rejects the selected backup or recovery procedure.

SAPDBA Functions

SAPDBA can restore and back up an entire database or reset the database to a previous state. When you start a job, SAPDBA is automatically started. SAPDBA functions are determined by the properties that are set in `util_par_file`.

For more information on setting `util_par_file` properties, see the section `Configure Parameter File Settings` in the "Installing the Option" chapter.

The following table describes the modules that are available for Oracle database administration:

Module	Function
BRBACKUP	Brings database servers online or offline, checks the file status, and places database tablespaces into backup mode to maintain consistency.
BRARCHIVE	Provides online and offline backup of control files, data files, and online redo log files as well as profiles and logs for backups.
BRRESTORE	Recovers database data files, control files, and online redo log files. Checks for available space prior to a restore while removing files that may be overwritten during the recovery.

When these modules are used, events are logged in the file system and corresponding database tables. When BRBACKUP or BRARCHIVE runs, backup logs and profiles are saved, enabling sophisticated volume management.

Database Backup Using SAPDBA

SAPDBA lets you back up complete databases or individual database objects such as tablespaces, control files, or archive logs. It works with BrightStor ARCserve Backup to back up data while the database is online or offline. When performing an online backup, the database is running and still accessible to users; when performing an offline backup, the database shuts down and is inaccessible to users.

Back Up Online Databases with SAPDBA

To back up online databases with SAPDBA, follow these steps:

1. Log onto SAPDBA.

The SAPDBA main screen appears as shown in the following example:

```

SAPDBA U4.6D - SAP Database Administration
-----
ORACLE version: 8.1.5.0.0
ORACLE_SID   : CER
ORACLE_HOME  : /qa/oracle/CER
DATABASE     : shut down
SAPR3        : not connected

a - Startup/Shutdown instance   h - Backup database
b - Instance information        i - Backup offline redo logs
c - Tablespace administration  j - Restore/Recovery
d - Reorganization             k - DB check/verification
e - Export/import              l - Show/Cleanup
f - Archive mode               m - User and Security
g - Additional Functions

q - Quit

Please select ==>

```

2. Enter **h**—Backup database.

The Backup Database screen appears as shown in the following example:

```

Backup Database
-----
Current value
a - Backup function             Normal backup
b - Parameter file              initCER.sap
c - Backup device type          external backup tool (backint)
d - Objects for backup          all
e - Backup type                 offline (force)
g - Query only                  no
h - Special options ...

i - Standard backup             yes
j - Backup from disk backup
l - Restart backup
m - Make part. backups compl.

S - Start BRBACKUP (U4.6D)
q - Return

Please select ==>

```

3. Enter **c**—Backup device type.

The Select backup device type screen appears as shown in the following example:

```

Select backup device type (2001-12-12)

Current selection: external backup tool (backint)

a - local tape
b - local tape auto changer
c - local tape juke box
d - remote tape
e - remote tape auto changer
f - remote tape juke box
-> g - external backup tool (backint)
h - external backup tool (backint) online
i - external backup tool (backint) with rman
k - local disk
l - local disk (create database copy)
m - local disk (create standby database)
n - remote disk
o - remote disk (create database copy)
p - remote disk (create standby database)

q - Return

Please select ==>

```

4. Enter **g**—external backup tool (BACKINT). This is the only device type you can select when using SAPDBA for online database backup.
5. Enter **q** to return to the previous screen.
6. At the Backup Database screen, select **m** - Back up type.
7. At the Backup type screen, select **a** - online.
8. Enter **q** to return to the previous screen.
9. Enter **d**—Objects for back up.

The text appears as shown in the following example:

```

Backup Mode/Backup Objects

Current selection: "all"

a - "all" - whole database backup
b - "all_data" - whole database without index tablespaces
c - "full" - full backup (level 0)
d - "incr" - incremental backup (level 1)
e - "sap_dir" - SAP directories backup
f - "ora_dir" - ORACLE directories backup
g - - a tablespace name
h - - an ORACLE file id <number>
  - or a range of file ids <number>-<number>
i - - an absolute file or directory name
j - - a combination: <item> or <item>,<item>,...

q - Return

Please select ==>

```

10. Enter **q** to return to the Backup database screen.
11. Enter **s**—Start BRBACKUP to begin the back up.

Back Up Offline Databases with SAPDBA

To back up offline databases with SAPDBA, follow these steps:

1. Log onto SAPDBA.
The SAPDBA main screen appears.
2. Enter **h**—Backup database.
The Backup database screen appears.
3. Enter **e**—Backup device type.
The Backup device type screen appears.
4. Enter **f**—util_file. This is the only device type you can select when using SAPDBA for offline database backup.
5. Enter **q** to return to the previous screen.
6. Enter **m**—back up type at the Backup Database screen.
7. Ensure that **b**—offline is selected at the Backup type screen.
8. Enter **q**—to return to the previous screen.
9. Enter **d**—Objects for backup.

The Backup Mode/Backup Objects screen appears as shown in the following example:

```

Backup Mode/Backup Objects

Current selection: "all"

a - "all"      - whole database backup
b - "all_data" - whole database without index tablespaces
c - "full"     - full      backup (level 0)
d - "incr"    - incremental backup (level 1)
e - "sap_dir" - SAP      directories backup
f - "ora_dir" - ORACLE  directories backup
g -          - a tablespace name
h -          - an ORACLE file id <number>
                or a range of file ids <number>-<number>
i -          - an absolute file or directory name
j -          - a combination: <item> or <item>,<item>,...

q - Return

Please select ==>

```

10. After you select an object for backup, enter **q** to return to the Back up database screen.
11. Enter **s**—Start BRBACKUP to begin the backup.

Back Up Offline Redo Logs

To back up offline redo logs:

1. Log onto SAPDBA.

The SAPDBA main screen appears.

2. Ensure that SAPDBA is in archive log mode and that automatic archival is enabled.

For more information, see the section How the Administrator Configures the Oracle Server Application in the "Installing the Option" chapter.

3. Enter **i**—Backup offline redo logs.

The Backup archive logs screen appears as shown in the following example:

```

Backup archive logs
-----
a - Archive function           Current value
b - Parameter file            Save archive logs
c - Confirm archive parameters no
d - Language                  English
e - Archive device type       tape
g - Number of redo logs      10000
h - Enter password interactively no
i - Query only                no
j - Archive volume(s)
k - Compress                  no
l - Verification after backup no
m - Continue until end of tape no

s - Start BRARCHIVE
q - Return

Please select ==> █

```

4. Enter **e**—Archive device type, at the Backup archive logs screen.

The Select archive device type screen appears as shown in the following example:

```

Select archive device type
-----

Current selection: tape

-> a - tape
    b - tape_auto
    c - pipe
    d - pipe_auto
    e - disk
    f - util_file
    g - util_file_online

    q - Return

Please select ==> █

```

5. Enter **g**—util_file_online, at the Archive device type screen. This is the only archive device type you can select when using SAPDBA for archive redo log backup.
6. Enter **q**—to return to the previous menu.
7. Enter **g**—Number of redo logs. When prompted, enter the number of redo logs.
8. Enter **q**— to return to the previous menu.
9. Enter **s**—Start BRARCHIVE.

Restore and Recover Using SAPDBA

To restore or recover databases with SAPDBA, follow these steps:

1. Log onto SAPDBA.

The SAPDBA main screen appears.

2. Ensure that Expert mode is ON.

Note: Before restoring data through SAPDBA, you must be in Expert mode. See your SAP manual for instructions.

3. From the main screen, enter **k**—Restore/recovery.

The Restore / Recovery screen appears as shown in the following example:

```
Restore / Recovery (2001-12-12)

a - Partial restore and complete recovery (Check and repair,
    redo logs and control files are prerequisites)
b - Full restore and recovery
    (excl. redo logs, control files incl. if required)
c - Reset database
    (incl. redo logs and control files)

d - Restore one tablespace
e - Restore individual file(s)

h - Help

q - Return

Please select ==>
```

Full Restore lets you restore the database and startup open (no recovery possible), or restore the database and startup mount (for manual recovery using the backup control file).

Full Restore and Recovery allows you to select a full online or offline backup, restore and recover database objects, recover until (allows you to choose among proper timestamps), or show the status of the job.

4. Choose the type of restore from the Restore/Recovery menu options.

See your SAP manual for more information about completing the remaining restore or recovery steps.

The BACKINT Job Status

When you use BACKINT to back up or restore a database, you can view the status of the job using BrightStor ARCserve Backup or SAPDBA.

For more information on checking the status of a job initiated with BrightStor ARCserve Backup, BACKINT, and SAPDBA, see the section Job Status Information in the "Troubleshooting" appendix.

Chapter 5: Best Practices

This chapter presents best practices for using the Enterprise Option for SAP R/3 for Oracle to backup and restore Oracle databases managed by SAP R/3 for Oracle.

Recommended Backup Procedures

We recommend following these backup procedures:

- When a database is initially created, perform a full offline backup of the entire database using BrightStor ARCserve Backup without the option. This provides copies of all data files, redo log files, and control files of your database.
- Perform an online backup of your Oracle databases.
- Extensively used tablespaces should be backed up frequently to reduce database recovery time.

For more information about Oracle backup and recovery procedures, see the Oracle Server Administrator's Guide.

Effective Backup and Recovery Strategies

Plan your backup and recovery strategies for a database before you create the database, and maintain a regular backup schedule to ensure smooth recovery in case of database or media failure. If such planning is not considered before database creation, database recovery may not be possible in certain cases.

For more information about disaster recovery planning, see the "Disaster Recovery" appendix.

When you develop your backup and recovery strategy, consider the following:

- **Full backups**—Full database backups should be performed regularly; it is easier to recover a database from a full backup.
- **Tablespace-level backups**—Recoverable databases allow tablespace-level backups, which can be done online or offline. For an isolated application error, it is easier to restore from a tablespace-level backup image.
- **Online or offline backups**—Offline backups are usually faster, but require exclusive access to the database. Online backups reduce the database downtime; however, they allow other connections to the database while the backup is taking place.

Test Environment

Test your backup and recovery strategy in a test environment before you move to a production system. By thoroughly testing your proposed backup and recovery strategy, you can identify and correct unexpected problems before they occur in a production situation.

Log File Protection

Do not overwrite log files if you archive and retrieve files on the same directory. To protect your archived log files, restore them to a separate retrieval directory.

Backups After Organizational Changes

Initiate a backup each time you take the following actions:

- Rename a tablespace.
- Restore a tablespace that has been renamed, using the new tablespace name.
- Reorganize a table.
- Back up a corresponding tablespace after you reorganize a table.
- Change the tablespace or database configuration.
- Change anything in the configuration or organization of a database or tablespace.

Current Option Information

To ensure that you are current with the latest information about the option, visit Computer Associates Customer Support at <http://ca.com/support>.

Appendix A: Troubleshooting

The following sections provide helpful information about:

- Debug Methods
- Option Activity Log File
- Job Status Information
- Database Manager
- BACKINT Job Status

Debug Methods

When troubleshooting the Enterprise Option for SAP R/3 for Oracle, we recommend that you generate and view a debugging trace file. The following sections describe how to enable debugging for the option, the backup agent integration module (BACKINT), and the Oracle Recovery Manager.

Enable Debugging for the Option

The option supports the creation of a debugging log for troubleshooting. Debugging is disabled by default.

Important! *Be very careful when making changes to the Windows Registry. Improper entries can affect the functionality of the product and the operation of your computer.*

To enable debugging for the option, follow these steps:

1. On the Windows Start menu, click Run.

The Run dialog opens.

2. In the Open field, enter:

```
regedit
```

3. Click OK.

The Registry Editor window opens.

Enable Debugging for the Backup Option Integration Module

The option supports the creation of a debugging log for troubleshooting the backup option integration module (BACKINT). Debugging is disabled by default.

Important! *Be very careful when making changes to the Windows Registry. Improper entries can affect the functionality of the product and the operation of your computer.*

To enable debugging for the backup option integration module, follow these steps:

1. On the Windows Start menu, click Run.

The Run dialog opens.

2. In the Open field, enter:

```
regedit
```

3. Click OK.

The Registry Editor window opens.

4. In the tree view pane, expand the following folders to view this registry path:

```
SOFTWARE\ComputerAssociates\BrightStor ARCserve Backup
\DSAgent\CurrentVersion\BACKINT
```

The resulting display should be similar to the following:

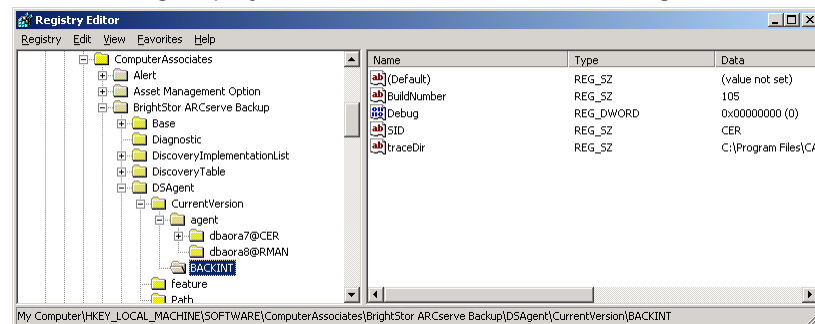

5. Double-click the debug entry in the Name list.

The Edit String dialog opens.

6. In the Open field, change the debug value from 0 (debugging disabled) to 1 (debugging enabled). By default, the debugging trace file is created in the installed option home directory.

7. Click OK.

8. If you want the debugging trace file to be created in a different directory, follow these steps, otherwise, continue with Step 9.
 - Double-click the traceDir entry in the Name list. The Edit String dialog opens.
 - In the Open field, enter the complete path name for the directory where you want the BACKINT trace file to be created.
 - Click OK.
9. Close the Registry Editor.

Important! *Be sure to set the key entry back to 0 (disabled) when you have finished troubleshooting to prevent the needless consumption of disk space and CPU time by the creation and maintenance of a debugging file.*

Registry Settings for RMAN Support

The agent uses a separate registry entry for RMAN support under the following key:

```
SOFTWARE\ComputerAssociates\BrightStor ARCserve Backup  
\DSAagent\CurrentVersion\agent\dbaora8@RMAN
```

Depending on circumstances, you may want to add or change the following registry parameters under this key:

- Timeout
- SessionStartTimeout
- Debug

The following sections explain what the parameters are and the circumstances in which you may want add or change them.

Important! *Before you add or change any values in the registry, consult with Computer Associates Customer Support to ensure the changes you intend to make are necessary and valid.*

Timeout

Timeout is the time in seconds the agent waits for Oracle to respond to calls made by orasbt.dll during a backup using RMAN. If the time exceeds the Timeout value, the agent stops the backup and the backup fails.

The Timeout parameter does not initially exist in the registry. Instead, the agent has a default, programmatic Timeout value of ten minutes. If you are experiencing frequent backup failures because Oracle fails to respond to orasbt.dll calls in the allotted time, you can create a Timeout parameter in the registry and set its value to greater than ten minutes. The value you set in the registry becomes the value the agent uses.

SessionStartTimeout

SessionStartTimeout is the time in seconds that the agent waits for the BrightStor ARCserve Backup server to begin an RMAN tape backup session. If the time exceeds the SessionStartTimeout value, the agent stops the backup and the backup fails.

The SessionStartTimeout parameter does not initially exist in the registry. Instead, the agent has a default, programmatic SessionStartTimeout value of ten minutes. If you are experiencing frequent backup failures because the BrightStor ARCserve Backup server fails to start an RMAN tape backup session in the allotted time, you can create a SessionStartTimeout parameter in the registry and set its value to greater than ten minutes. The value you set in the registry becomes the value the agent uses.

Debug

Changing the Debug parameter to the following setting activates the debug trace logs for the agent, called orasbt.trc and dbaora8.trc:

```
debug:REG_DWORD:1 (TRUE)
```

The logs are written to the agent home directory. Change this setting only when requested to by Computer Associates Customer Support.

Note: The default value of Debug is 0 (FALSE).

Option Activity Log File

During operation, the option generates an activity log file that records information about backup and restore jobs as they are run. The information in this log file can help solve problems you may encounter when performing an operation.

The option activity log is named dbaora7.log and is located in the directory in which the option is installed. If errors appear in the BrightStor ARCserve Backup job logs, check the option log for more information on why the errors occurred.

Job Status Information

When you use the option to back up or restore a database, you can view the status of the job. To monitor the job activity, click the Job Status icon in the BrightStor ARCserve Backup Quick Start window:

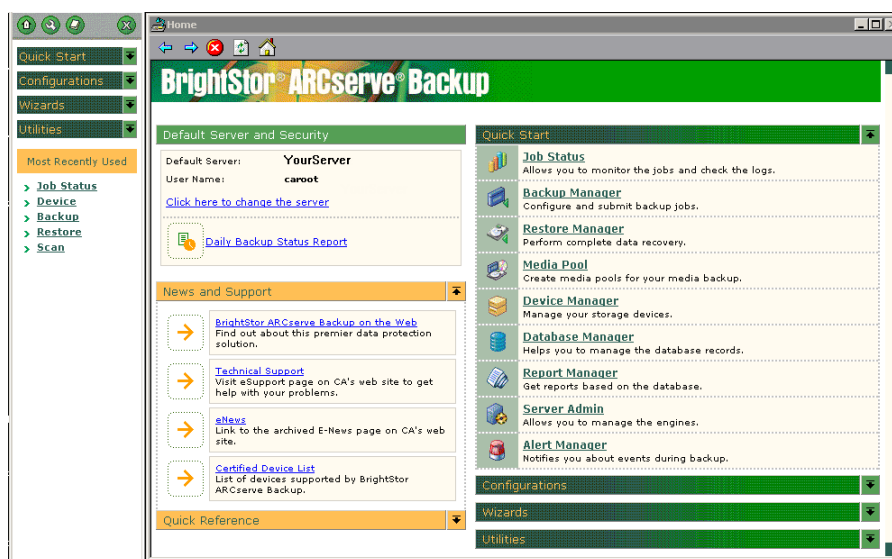

After you submit a backup or restore job to BrightStor ARCserve Backup by the option, you can monitor the status of the job using the Job Status Manager:

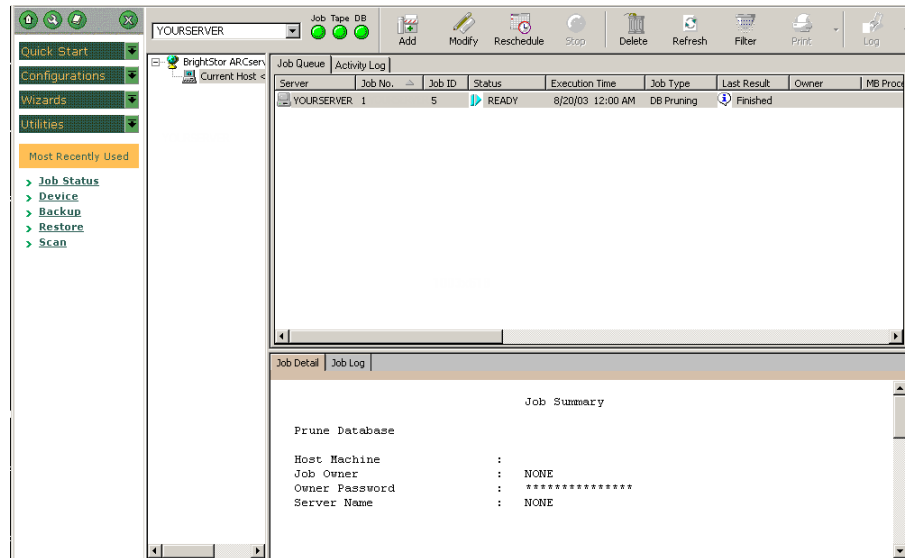

For more information about the Job Status Manager, see the *Administrator Guide* and the *Getting Started*.

Database Manager

You can use the BrightStor ARCserve Backup Database Manager to view detailed information about your backup job. You can view backed up file names, media name, and session information.

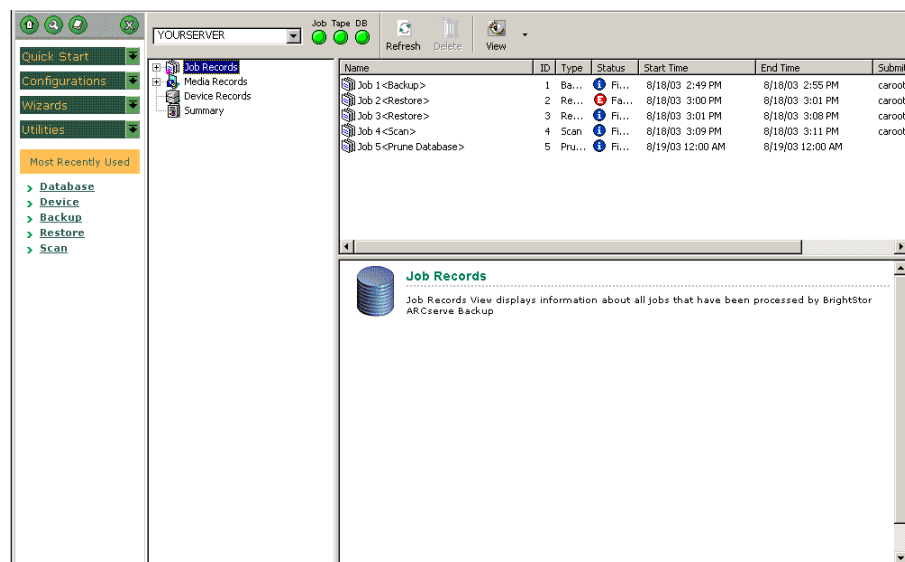

BACKINT Job Status

After a backup or restore job is submitted to BrightStor ARCserve Backup by BACKINT, you can monitor the status of the job from the BrightStor ARCserve Backup Job Queue window. The option backup ID is used to identify the backup job in the Job Queue window, and is displayed in the owner field.

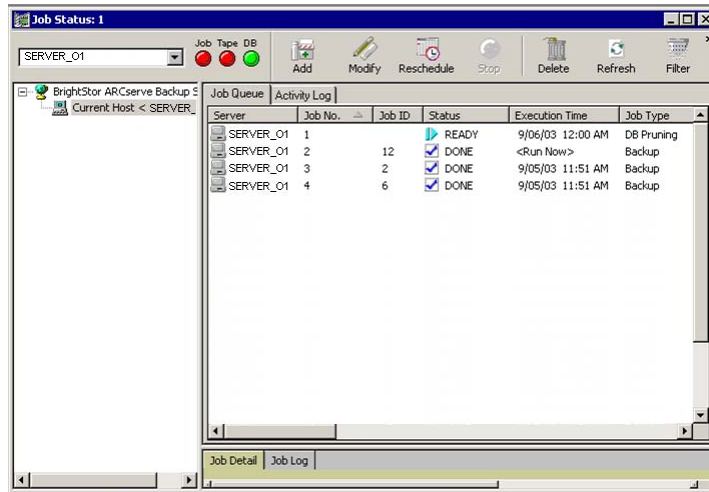

Appendix B: Disaster Recovery

Planning your backup methodology in advance is critical for protecting your database against failures, and for quick recovery of your database server in case of disaster.

For most efficient disaster recovery, implement the following backup strategy:

- Perform a full offline backup of your Oracle data files, configuration files, and registry information so you can restore an offline image of Oracle server.
- Perform a full offline or online backup each time there is a major schema change in your databases (for example, when you delete a tablespace, create a new one, or add a data file). A full offline backup is not required, but it is highly recommended.
- Perform full online backups regularly; for example, once a week. You can choose to back up only the archive redo log files for the remaining days of the week, if the time needed for a full online backup prohibits a full backup.

Scenarios for Restoring to the Original Windows Server

Assume you have a Windows server running Oracle, and that there are two Oracle database instances on the server: ORCL and DB2. A disaster occurs and it is necessary to rebuild the entire server.

Recovery of your Oracle databases proceeds in two phases, each of which is explained in detail in the following sections:

- Phase 1 - Recover the ORCL database
- Phase 2 - Recover the DB2 database

Recover the ORCL Database

You must create an Oracle instance before you start the recovery procedure. Because you had the starter database (ORCL) when reinstalling Oracle, we recommend that you create the instance for DB2.

1. Reinstall Windows.
2. Install BrightStor ARCserve Backup if it was on the same server as your Oracle databases.
3. Do **one** of the following:

- Reinstall Oracle
- Restore all necessary sessions (files) from media (for example, sessions for Oracle executables, configuration files and registry information)

4. Reinstall the option, and create an Oracle database instance entry for **each** of the instances you intend to restore.
5. Restore the last full backup of ORCL.

Note: If it is an offline backup, then no further recovery is needed. Proceed to the section Recover the DB2 Database in this appendix. If it is an online backup, continue with the next step.

6. Check the INITORCL.ORA file to see if it contains all the necessary settings for the following entries:

```
LOG_ARCHIVE_START  
LOG_ARCHIVE_DEST  
LOG_ARCHIVE_FORMAT
```

7. Copy the restored control file (CONTROL.ORCL) from the option home directory to all necessary directories and rename this file with the appropriate name.
8. Connect to ORCL as user INTERNAL or as a user SYSTEM.
9. Mount the database.

10. Enter the following command at the SVRMGR or SQLPLUS prompt:

```
recover database using backup controlfile until cancel;
```

11. When the recovery has been completed, enter the following command:

```
alter database open resetlogs
```

Note: If the database does not open and a message reports on the status of the redo logs, enter the following query at the SVRMGR or SQLPLUS prompt:

```
select * from v$logfile
```

This query returns, among other information, the directory structure in which Oracle looks for the redo logs. If the directory structure does not exist, create it. When you have done so, enter the following command again:

```
alter database open resetlogs
```

Oracle should open the database and recreate the redo logs.

Important! *The following step is very important. DO NOT OMIT IT.*

12. Delete all archive logs for ORCL.

The ORCL database is now fully recovered. You can now proceed to the second phase, recovering the DB2 database.

Recover the DB2 Database

To recover the DB2 database, follow these steps:

1. Create an instance for the DB2 database and start the DB2 instance.
2. Make sure the INITDB2.ORA file contains all the necessary configuration information, as described in Step 6 of the previous phase. Do one of the following:
 - Restore the latest backup copy of the INITDB2.ORA file from media.
 - Recreate this file by using INITORCL.ORA as your template and making all the necessary changes to it.
3. Restore the last full backup of DB2.

Note: If it is an offline backup, then no further recovery is needed. You have now completed recovery of your Oracle server.

4. Copy the restored control file (CONTROL.DB2) from the option home directory to all necessary directories and rename it with the appropriate name.
5. Connect to the instance you started in Step 1 of this procedure.
6. To mount the DB2 database, enter the following command:

```
startup mount pfile=DRIVE:\PATH\initDB2.ora
```

7. Enter the following command at the SQLDBA or Server Manager prompt:

```
recover database using backup controlfile until cancel;
```

8. When the recovery has been completed, enter the following command:

```
alter database open resetlogs
```

If the database does not open and a message reports on the status of the redo logs, enter the following query at the SQLDBA or Server Manager prompt:

```
select * from v$logfile
```

This query returns, among other information, the directory structure in which Oracle looks for the redo logs. If the directory structure does not exist, create it. When you have done so, enter the following command again:

```
alter database open resetlogs
```

Oracle should open the database and recreate the redo logs.

9. Delete all archive logs for DB2. The DB2 database is now fully recovered.

10. (Optional) You can recreate an instance for DB2 using the oradim utility (for example, oradim.exe for Oracle 8.1.7). The syntax is:

```
oradim -new -sid SID -srv ServiceName -intpwd Password -startmode auto  
| manual -pfile FullPathToOracleInitSIDFile
```

11. (Optional) Create the password file if necessary, using the orapwdx.exe utility.

Scenarios for Restoring to an Alternate Server

For faster disaster recovery, you may prefer restoring the Oracle database to a different server than the original server. In this section, we present two typical scenarios as examples for restoring to alternate servers:

- Scenario 1 - The alternate server can support the exact directory structures of the original Oracle server.
- Scenario 2 - The alternate server cannot support the exact directory structures of the original Oracle Server. For example, the destination server does not have a volume (such as drive f:) that the original server had.

Restore to a Server that Supports Exact Directory Structures

To restore to an alternate server that can support the exact directory structure, follow these steps:

1. Install the option on the target server, and add an additional database instance for the new database that you want to recover.
2. Create an ORACLE instance or PWFIL if necessary.
3. In the BrightStor ARCserve Backup Restore Manager, clear the Restore to Original Location option.
4. Restore all necessary recovery files (for example, configuration files) to the original location on the target server.
5. Restore the database to the target's temporary directory (the temporary directory is where you would like to keep the files—database files, archive logs, and control files).
6. Move database files and archive logs to their original location on the target server.
7. Copy the restored control file (CONTROL%SID%) to all necessary directories and rename it with the appropriate name.
8. After the database files are restored, you can follow the same steps for recovering the Oracle database as described in the section Recover the ORCL Database in this appendix.

Restore to a Server with Different Directory Structures

To restore to an alternate server that cannot support the exact directory structure, follow these steps:

1. Install the option on the target server, and add an additional Oracle database instance for the new database that you want to recover.
2. Create an ORACLE instance or PWFIL if necessary, as described in the section Recover the ORCL Database in this appendix.
3. In the BrightStor ARCserve Backup Restore Manager, clear the Restore to original location option.
4. Restore all necessary recovery files (for example, configuration files) to a new location on the target server.
5. Restore the database to the target's temporary directory (the temporary directory is where you would like to keep the files—database files, archive logs, and control files).
6. Move database files and archive logs to their new location on the target server.
7. Edit the INITSID.ORA to reflect your new directory structure. Because the directory structures are different from the original, the control files must be recreated.
8. Start up the instance but **do not mount or open** the database.
9. Connect to the instance.

10. Execute the following command:

```
Startup nomount
```

11. Issue the create control file command.

For the exact syntax, see the Oracle Administrators Guide. An example might be:

```
create controlfile
set database TEST
logfile group 1('e:\oracle\test\redlog1a.ora') size 200K,
group 2('e:\oracle\test\redlog1b.ora') size 50K
RESETLOGS
datafile 'e:\oracle\test\sysstest.ora' size 10M,
'e:\oracle\test\testrollback.dbs' size 2M
maxlogfiles 50
maxlogmembers 3
maxdatafiles 200
maxinstances 6
archivelog;
```

Note: The user has specified the RESETLOGS and ARCHIVELOG options.

12. Ensure that the control file is copied to all necessary locations and renamed with the appropriate name.

13. Enter the following command:

```
Recover database using backup controlfile until cancel;
```

14. When the recovery is complete, enter the following command:

```
Alter database open resetlogs
```

This action recreates the redo logs and opens the database. If you get an error, check the previous section.

15. Delete the archive logs.

Appendix C: Sample util_par_file and Parameter Definitions

This appendix provides descriptions for a sample backup option integration module (BACKINT) parameter file util _par_file. You can find the file in the \$ORACLE_HOME\database directory.

Sample File

```
-- par_file ( init0R2.utl )---
#####
# This is the parameter file of BACKINT for BrightStor ARCserve Backup
# containing parameters that determine the backup procedure.#
# BACKINT reads this file and submits a job to the BrightStor ARCserve
# Backup queue for execution.
#
#Instructions for filling out each line start with a pound sign (#) and
# precede the actual information line that the user needs to fill in.#
#####
# Tape Name that BrightStor ARCserve Backup should use for the backup (eg.
# tape0, tape1,..., or '*')
# DESTTAPE=*
# Group Name that BrightStor ARCserve Backup should use for the backup
# (eg. GROUP0, GROUP1,..., or '*')
# DESTGROUP=*
# First Tape Option that BrightStor ARCserve Backup should use for the
# backup (eg. APPEND or OVERWRITE)
# APPEND: Append job sessions to the selected tape
# OVERWRITE: Overwrite any tape found in the drive only for the first
# BACKINT call
# TAPEMETHOD=APPEND
# volumes for brarchive/brbackup
# [volume_name | volume_name_list | SCRATCH]
# no default
# volume_archive_line = 2
# volume_archive1 = XXLA01, XXLA02, XXLA03, XXLA04, XXLA05
# volume_archive2 = XXLA06, XXLA07, XXLA08, XXLA09, XXLA10
```

```
# volume_backup_line = 2
# volume_backup1 = XXLB01, XXLB02, XXLB03, XXLB04, XXLB05
# volume_backup2 = XXLB06, XXLB07, XXLB08, XXLB09, XXLB10
# expiration period for backup volumes in days
# default: 0
# expir_period = 30
#####
Login information for communication with BrightStor ARCserve Backup on
remote server
#####
[Remote]
REMOTE_FLAG = 0
LOCAL_COMPUTER_NAME=Local_Server
LOCAL_USER_NAME=Local_User
LOCAL_PASSWORD=t
REMOTE_COMPUTER_NAME=Remote_BrightStor ARCserve Backup_Server
REMOTE_USER_NAME=Remote_BrightStor ARCserve Backup_User
REMOTE_PASSWORD=t
#####
Automatic Volume Management for brbackup
#####
[Volume Brbackup]
DESTGROUP=*
DESTTAPE=*
TAPEMETHOD=APPEND
VOLUME_BACKUP_LINE=0
EXPIR_PERIOD=0
#####
Automatic Volume Management for brarchive
#####
[Volume Brarchive]
DESTGROUP=*
DESTTAPE=*
TAPEMETHOD=APPEND
VOLUME_ARCHIVE_LINE=0
EXPIR_PERIOD=0
[Internal]
first_call_tape_name=none
first_call_group_name=none
```

Parameter Definitions

The util_par_file configuration file is divided into several sections. The parameters for each section are described in the following sections of this guide.

Remote Section

This section stores the Windows security information for the local server so it can communicate with BrightStor ARCserve Backup on a remote server.

```
[Remote]
REMOTE_FLAG=BrightStor ARCserve Backup type
LOCAL_COMPUTER_NAME=Local server name
LOCAL_USER_NAME=Local user name
LOCAL_PASSWORD=Local user password
REMOTE_COMPUTER_NAME=Remote BrightStor ARCserve Backup server name
REMOTE_USER_NAME=Remote BrightStor ARCserve Backup server user name
REMOTE_PASSWORD=Remote BrightStor ARCserve Backup server user password
```

For example, if BACKINT integrates with BrightStor ARCserve Backup running on a remote server, you must set the REMOTE_FLAG=1, in addition to specifying the other Windows security information. If BACKINT uses local BrightStor ARCserve Backup, set REMOTE_FLAG=0, and do not set the other Windows security information.

Volume Brbackup Section

This section stores automatic volume management settings for BRBACKUP.

```
[Volume Brbackup]
DESTGROUP=BrightStor ARCserve Backup device group name
DESTTAPE=tape name
```

For example, if you use TAPE1 in GROUP0 for backup, set:

```
DESTGROUP=GROUP0
DESTTAPE=TAPE1
```

If you use any available group or tape for backup, set:

```
DESTGROUP=*
DESTTAPE=*
TAPEMETHOD=APPEND | OVERWRITE
```

The TAPEMETHOD can specify either APPEND or OVERWRITE. APPEND specifies that BrightStor ARCserve Backup appends job sessions to the selected tape; OVERWRITE specifies that BrightStor ARCserve Backup overwrites the selected tape for the first BACKINT call.

VOLUME_BACKUP_LINE=*number of lines*
VOLUME_BACKUPN=*tape names*

For example, if BRBACKUP uses TAPE1, TAPE2, TAPE3, TAPE4, TAPE5, TAPE6, TAPE7, TAPE8, TAPE9, and TAPE10 for backup sequentially, these lines should be:

VOLUME_BACKUP_LINE=2
VOLUME_BACKUP1=TAPE1, TAPE2, TAPE3, TAPE4, TAPE5
VOLUME_BACKUP2=TAPE6, TAPE7, TAPE8, TAPE9, TAPE10
EXPIR_PERIOD=*retention period in days*

Use the EXPIR_PERIOD parameter to define the number or days you want to prevent a tape from being overwritten.

For example, if you specify 10 days, BACKINT protects the tape from being overwritten for 10 days. This line should be:

EXPIR_PERIOD=10

For more information about the automatic volume management, see BCSAP Database Administrator: ORACLE.

Volume Brarchive Section

This section stores automatic volume management settings for BRARCHIVE.

[Volume Brarchive]
DESTGROUP=BrightStor ARCserve Backup device group name
DESTTAPE=*tape name*
TAPEMETHOD=*first tape option*
VOLUME_ARCHIVE_LINE=*number of lines*
VOLUME_ARCHIVEN=*tape names*
EXPIR_PERIOD=*retention period in days*

The definitions in this section are the same as those in the previous section.

Internal Section

This section contains no user-configurable settings. Do not delete or modify this section.

Index

A

- Access Control Lists (ACLs), creating • 26
- activity log • 70
- agent
 - activity log • 70
 - architectural overview • 8
 - backing up with
 - BrightStor ARCserve Backup • 33, 35
 - SAPDBA • 56
 - backup diagram • 12
 - fail safe environment, backing up in • 36
 - features • 7
 - functional limitations • 53
 - integration with
 - Recovery Manager • 14
 - SAPDBA • 9
 - networking capabilities • 8
 - removing • 30
 - restore diagram • 13
 - restoring with • 39
 - SAPDBA • 61
 - status, checking • 29
- alternative server
 - restoring to • 41
- architecture of agent • 8
- archived redo log files
 - backing up with SAPDBA • 60
 - do not overwrite • 64
 - protecting • 64
 - purging
 - disabling • 27
 - enabling • 28
 - restoring • 40, 41
- ARCHIVELOG mode
 - checking status of • 19

B

- backing up
 - activity log file • 70
 - in an Oracle Fail Safe environment • 36
 - job status • 71, 72

- limitations • 53
- recommended procedures • 63
- when to initiate backups • 64
- with SAPDBA • 56
- best practices • 63
- BRARCHIVE • 56
 - media management setting • 22
- BRBACKUP • 56
 - media management setting • 22
- BRRESTORE • 56

C

- control files, restoring • 39, 40
- customer support • 64

D

- data files, restoring • 39
- Database Manager, checking job status with • 71
- databases
 - backing up
 - with BrightStor ARCserve Backup • 33, 35
 - with SAPDBA • 57, 59
 - DB2 recovery • 75
 - fail safe environment, backing up in • 36
 - Oracle recovery • 74
 - recovering
 - from full offline backup • 53
 - with control files • 50
 - with SAPDBA • 61
 - restoring
 - with BrightStor ARCserve Backup • 39
 - with SAPDBA • 61
 - when to back up • 64
- dbaora7.log file • 70
- dbaora7.trc file • 65
- Debug • 69
- debugging
 - enabling for the agent • 65
 - for BACKINT • 67
- disaster recovery

restoring to alternate server • 76

F

fail safe environment
backing up in • 36

I

init<SID>.sap file
configuring • 26
location of • 26

installation
procedure • 17
instance, defined • 8

J

Job Queue, checking job status with • 72
job status, checking • 71, 72

L

limitations • 53
log files
activity log • 70
backing up with SAPDBA • 60
do not overwrite • 64
protecting • 64
purging
disabling • 27
enabling • 28
restoring • 40

M

media pool settings • 22

O

offline back ups
recovering from full backups • 53
with SAPDBA • 59
offline backups
restoring from • 43
with BrightStor ARCserve Backup • 35
online backups
with BrightStor ARCserve Backup • 33
with SAPDBA • 57
Oracle Fail Safe environment
backing up in • 36

P

parameter definitions, util_par_file • 82
See also util_par_file • 82
purging log files, enabling and disabling • 27

R

recovering
complete database
with control files • 50
DB2 database • 75
from offline full backups • 53
Oracle database • 74
with SAPDBA • 61
Recovery Manager
backup diagram • 15
configuring • 21
integration with the agent • 14
restore diagram • 16
redo log files
backing up with SAPDBA • 60
do not overwrite • 64
enabling and disabling purging • 27
protecting • 64
restoring • 40
registry settings
Debug • 69
SessionStartTimeout • 69
Timeout • 69
removing the agent • 30
restoring
activity log file • 70
alternate server • 76
basic concepts • 39
from offline backups • 43
job status • 72
limitations • 53
system tablespace • 43
to an alternate server • 41
with BrightStor ARCserve Backup • 39
with SAPDBA • 61
RMAN. See Recovery Manager • 21

S

SAP R/3 integration with the agent • 9
SAPDBA
backing up offline databases • 59
backing up online databases • 57
backing up with • 56

- backup diagram • 9
- capabilities with agent • 55
- functions • 56
- integration with the agent • 9
- menu options • 55
- modules • 56
- restore diagram • 10
- restoring databases • 61
- scenarios for disaster recovery • 73
- SessionStartTimeout • 69
- starting the agent • 29
- status
 - ARCHIVELOG mode • 19
 - checking agent status • 29
- stopping the agent • 29
- support contact • 64
- system tablespace, restoring • 40, 43

T

- tablespaces
 - restoring
 - with BrightStor ARCserve Backup • 39, 40
 - system, restoring • 40, 43
- test environment, implementing • 64
- Timeout • 69
- troubleshooting • 65

U

- uninstalling the agent • 30
- util_par_file
 - configuring parameters in • 22
 - location of • 22
 - parameter definitions • 82
 - sample • 81