

CA ARCserve® Backup for Windows

NDMP NAS Option Guide

r12.5



This documentation and any related computer software help programs (hereinafter referred to as the "Documentation") is for the end user's informational purposes only and is subject to change or withdrawal by CA at any time.

This Documentation may not be copied, transferred, reproduced, disclosed, modified or duplicated, in whole or in part, without the prior written consent of CA. This Documentation is confidential and proprietary information of CA and protected by the copyright laws of the United States and international treaties.

Notwithstanding the foregoing, licensed users may print a reasonable number of copies of the Documentation for their own internal use, and may make one copy of the related software as reasonably required for back-up and disaster recovery purposes, provided that all CA copyright notices and legends are affixed to each reproduced copy. Only authorized employees, consultants, or agents of the user who are bound by the provisions of the license for the Product are permitted to have access to such copies.

The right to print copies of the Documentation and to make a copy of the related software is limited to the period during which the applicable license for the Product remains in full force and effect. Should the license terminate for any reason, it shall be the user's responsibility to certify in writing to CA that all copies and partial copies of the Documentation have been returned to CA or destroyed.

EXCEPT AS OTHERWISE STATED IN THE APPLICABLE LICENSE AGREEMENT, TO THE EXTENT PERMITTED BY APPLICABLE LAW, CA PROVIDES THIS DOCUMENTATION "AS IS" WITHOUT WARRANTY OF ANY KIND, INCLUDING WITHOUT LIMITATION, ANY IMPLIED WARRANTIES OF MERCHANTABILITY, FITNESS FOR A PARTICULAR PURPOSE OR NONINFRINGEMENT. IN NO EVENT WILL CA BE LIABLE TO THE END USER OR ANY THIRD PARTY FOR ANY LOSS OR DAMAGE, DIRECT OR INDIRECT, FROM THE USE OF THIS DOCUMENTATION, INCLUDING WITHOUT LIMITATION, LOST PROFITS, BUSINESS INTERRUPTION, GOODWILL, OR LOST DATA, EVEN IF CA IS EXPRESSLY ADVISED OF SUCH LOSS OR DAMAGE.

The use of any product referenced in the Documentation is governed by the end user's applicable license agreement.

The manufacturer of this Documentation is CA.

Provided with "Restricted Rights." Use, duplication or disclosure by the United States Government is subject to the restrictions set forth in FAR Sections 12.212, 52.227-14, and 52.227-19(c)(1) - (2) and DFARS Section 252.227-7014(b)(3), as applicable, or their successors.

All trademarks, trade names, service marks, and logos referenced herein belong to their respective companies.

Copyright © 2009 CA. All rights reserved.

CA Product References

This document references the following CA products:

- BrightStor® ARCserve® Backup for Laptops and Desktops
- BrightStor® CA-Dynam®/TLMS Tape Management
- BrightStor® CA-Vtape™ Virtual Tape System
- BrightStor® Enterprise Backup
- BrightStor® High Availability
- BrightStor® Storage Resource Manager
- CA Antivirus
- CA ARCserve® Backup Agent for Advantage™ Ingres®
- CA ARCserve® Backup Agent for Novell Open Enterprise Server for Linux
- CA ARCserve® Backup Agent for Open Files on NetWare
- CA ARCserve® Backup Agent for Open Files on Windows
- CA ARCserve® Backup Client Agent for FreeBSD
- CA ARCserve® Backup Client Agent for Linux
- CA ARCserve® Backup Client Agent for Mainframe Linux
- CA ARCserve® Backup Client Agent for NetWare
- CA ARCserve® Backup Client Agent for UNIX
- CA ARCserve® Backup Client Agent for Windows
- CA ARCserve® Backup Enterprise Option for AS/400
- CA ARCserve® Backup Enterprise Option for Open VMS
- CA ARCserve® Backup for Microsoft Windows Essential Business Server
- CA ARCserve® Backup for Windows
- CA ARCserve® Backup for Windows Agent for IBM Informix
- CA ARCserve® Backup for Windows Agent for Lotus Domino
- CA ARCserve® Backup for Windows Agent for Microsoft Exchange
- CA ARCserve® Backup for Windows Agent for Microsoft SharePoint
- CA ARCserve® Backup for Windows Agent for Microsoft SQL Server
- CA ARCserve® Backup for Windows Agent for Oracle
- CA ARCserve® Backup for Windows Agent for Sybase
- CA ARCserve® Backup for Windows Agent for Virtual Machines

- CA ARCserve® Backup for Windows Disaster Recovery Option
- CA ARCserve® Backup for Windows Disk to Disk to Tape Option
- CA ARCserve® Backup for Windows Enterprise Module
- CA ARCserve® Backup for Windows Enterprise Option for IBM 3494
- CA ARCserve® Backup for Windows Enterprise Option for SAP R/3 for Oracle
- CA ARCserve® Backup for Windows Enterprise Option for StorageTek ACSLS
- CA ARCserve® Backup for Windows Image Option
- CA ARCserve® Backup for Windows Microsoft Volume Shadow Copy Service
- CA ARCserve® Backup for Windows NDMP NAS Option
- CA ARCserve® Backup for Windows Serverless Backup Option
- CA ARCserve® Backup for Windows Storage Area Network (SAN) Option
- CA ARCserve® Backup for Windows Tape Library Option
- CA Dynam®/B Backup for z/VM
- CA VM: Tape for z/VM
- CA XOssoft™ Assured Recovery™
- CA XOssoft™
- CA 1® Tape Management
- Common Services™
- eTrust® Firewall
- Unicenter® Network and Systems Management
- Unicenter® Software Delivery
- Unicenter® VM: Operator®

Contact CA

Contact Technical Support

For your convenience, CA provides one site where you can access the information you need for your Home Office, Small Business, and Enterprise CA products. At <http://ca.com/support>, you can access the following:

- Online and telephone contact information for technical assistance and customer services
- Information about user communities and forums
- Product and documentation downloads
- CA Support policies and guidelines
- Other helpful resources appropriate for your product

Provide Feedback

If you have comments or questions about CA product documentation, you can send a message to techpubs@ca.com.

If you would like to provide feedback about CA product documentation, complete our short [customer survey](#), which is also available on the CA support website, found at <http://ca.com/support>.

Contents

Chapter 1: Introducing the Option	11
Introduction	11
Features	11
Option Architecture	13
Network Data Management Protocol (NDMP)	13
NAS Server	14
Remote Browsing	14
Supported NAS Backup Configurations	14
How the Option Backs Up Data	15
How the Option Restores Data	16
Restore by Source	17
Restore by Destination	17
Dynamic Device Sharing	18
Supported DDS Configurations	19
Log Access	20
Chapter 2: Installing the Option	21
Installation Prerequisites	21
Option Installation	22
File System Configuration	22
Configure NDMP Version 3	22
Configure NDMP Version 4	24
Snapshots and Checkpoints Configuration	24
Option Configuration	25
Configure NAS Devices	26
How You Configure Dynamic Device Sharing	30
Chapter 3: Using the Option	33
How You Manage Backup Operations	33
Backup Options	33
Backup Prerequisites	34
Add a NAS Server	34
Back Up a NAS Server	36
Perform a Staging Backup of a NAS Server	39
How You Can Archive Data on the NAS Server	40
How You Manage Restore Operations	40

Restore Options	40
Restore Methods	41
How You Manage Devices and Media	47
Adapter, Device, and Group Views	47
Media Management	47
How You Manage the Database and Reports	48
How You Manage NAS Operations Using CA ARCserve Backup Utilities	48
Merge Utility	48
Media Assure & Scan Utility	48

Appendix A: Using Network Appliance NAS Devices **51**

Network Appliance Servers Configuration	51
Access the Administrative Interface	51
View the Netapp System Log	51
User Accounts	52
Enable NDMP on Network Appliance Devices	52
Configure Tape Library Device Names	53
Configure the Drive Access Path	53
Snapshot Configuration	54
Option Limitations on Network Appliance Devices	56

Appendix B: Using EMC Celerra NAS Devices **57**

How the EMC Celerra Host Data Mover Works	57
Configure the EMC Celerra Data Mover	58
User Accounts	58
Enable NDMP on EMC Celerra Devices	58
Logical Device Names Detection	59
nas.cfg File Configuration - EMC Celerra Devices	60
Option Limitations on EMC Celerra Devices	60

Appendix C: Using EMC CLARiiON IP4700 NAS Devices **61**

Configure the EMC CLARiiON IP4700 NAS Server	61
User Accounts	61
Enable NDMP on EMC CLARiiON IP4700 Devices	61
Logical Device Names	62
Network Configuration	63
Volume Configuration	63
Tape Drives and Tape Libraries	63
Option Limitations on EMC CLARiiON IP4700 Devices	64

Appendix D: Using Procom NAS Devices	65
Procom Server Configuration	65
User Accounts	65
Logical Device Names	65
Network Configuration	66
Volume Configuration	67
Tape Drives and Tape Library Units	67
nas.cfg File Configuration - Procom Devices	67
Option Limitations on Procom Devices	69
Appendix E: Troubleshooting	71
Devices Do Not Display in the Device Manager	71
NAS Server Does Not Reinitialize	72
Debugging is Not Enabled on the NAS Server	72
Cannot Access the Procom System Log and Environmental Log	73
Unable to Restore QTree Information Using the NDMP NAS Option	74
Appendix F: Feature Support Summary	75
Supported Backup Features	75
Supported General Features	77
Supported Restore Features	78
Support for NDMP V4	79
Certified NAS Devices	79
Index	81

Chapter 1: Introducing the Option

This section describes the features and architecture of the option.

This section contains the following topics:

[Introduction](#) (see page 11)

[Features](#) (see page 11)

[Option Architecture](#) (see page 13)

[How the Option Backs Up Data](#) (see page 15)

[How the Option Restores Data](#) (see page 16)

[Dynamic Device Sharing](#) (see page 18)

Introduction

CA ARCserve Backup is a comprehensive storage solution for applications, databases, distributed servers, and file systems. It provides backup and restore capabilities for databases, business-critical applications, and network clients.

Among the options CA ARCserve Backup offers is the CA ARCserve Backup NDMP NAS Option. This option lets you back up and restore data on Network Attached Storage (NAS) devices using Network Data Management Protocol (NDMP). The CA ARCserve Backup NDMP NAS Option application resides on the same application server as CA ARCserve Backup and handles all communication between CA ARCserve Backup and the NAS server that performs backup and restore jobs.

Features

The NDMP NAS Option includes the following feature set:

Push Technology

You can complete a backup more efficiently by processing the data locally at the NAS server. Push technology offloads system resources from the CA ARCserve Backup host server and minimizes network traffic by initiating the backup and restore jobs remotely on the NAS server.

Real-time Remote Browsing

System administrators can view real-time file and directory information about the remote target machine.

Note: This feature requires NAS-vendor support.

Local and Three-way NDMP Backups and Restores

As long as one NAS server has an attached tape device, you can use the attached tape device for backing up data from any other NAS servers in the configuration. The tape device does not need to be attached locally to the NAS server to back up or restore that server.

Note: When you move NAS tape devices from one NAS server to a different NAS server the new hardware configuration results in a three-way restore operation.

NAS Changer Support

The NDMP NAS Option supports backing up and restoring NAS servers using changers or tape library units attached locally to a NAS server or remotely to a different NAS server. This feature lets you back up and restore a local or remote NAS server using a three-way NDMP backup or restore.

Multistreaming Support

One agent can handle different requests and perform multiple jobs simultaneously.

NAS 64-bit Support

The NDMP NAS Option now supports X64 CA ARCserve Backup servers to back up NAS filers. (IA64 is not supported)

Tapecopy Support

The tapecopy utility allows you to copy NAS sessions from one tape to another. This tapecopy support provides the following NAS session capabilities:

- Perform a tapecopy backup of normal NAS sessions
- Perform a tapecopy backup of NAS sessions with or without a tape span situation (involving one or more tapes)
- Perform a tapecopy backup of NAS sessions from the query mode
- Perform a tapecopy backup of NAS sessions using the "-entire" source option which allows you to copy all tapes in a group to another group.

Most tapecopy switches can be used; however, some limitations apply for tapecopy support of NAS sessions:

- The tapecopy source and destination groups should be SAN DDS groups (accessible to both the CA ARCserve Backup server and the NAS filer).
- Does not support remote copy (using SAN/NAS DDS environment)
- Does not support copy to a FSD or from a FSD.
- Does not support multiplexing and encryption

Dynamic Device Sharing

The option uses dynamic device sharing (DDS) to enable the CA ARCserve Backup server to share tape library units (TLU) on a storage area network (SAN). You can share a TLU between multiple NAS servers exclusively, or share multiple NAS servers with a TLU and the CA ARCserve Backup server. DDS enables your environment to choose the optimal device to back up and restore data. For more information about DDS, see the section Dynamic Device Sharing.

Note: To use dynamic device sharing, you must install the following options:

- CA ARCserve Backup Enterprise Module
- SAN Option
- Tape Library Option

More information:

[Dynamic Device Sharing](#) (see page 18)

Option Architecture

The NDMP NAS Option provides services that allow CA ARCserve Backup to back up and restore files and directories. These services utilize several components in a variety of configurations to perform backups and restores.

Network Data Management Protocol (NDMP)

NDMP is a communication protocol that allows interaction with a NAS server on the network. It lets a backup application, such as CA ARCserve Backup, control the backup and retrieval of data performed by an NDMP server. The NDMP-enabled server executes on NAS servers. It enables data transfers between tape library units and disks connected locally and remotely to any NAS server on the network.

NDMP allows a network backup application, such as CA ARCserve Backup, to initiate backup operations from a network node. The backup application does not perform data movement. Instead, the NDMP server executing on the NAS server performs the data transfer.

More information:

[File System Configuration](#) (see page 22)

NAS Server

The NAS server implements the NDMP protocol and performs the actual backup and restore operations. The NDMP server executes on the NAS server and is supplied by the manufacturer of the NAS server. CA ARCserve Backup interfaces with the NDMP server running on the NAS server using NDMP.

Remote Browsing

CA ARCserve Backup automatically enumerates files and directories for Network Appliance servers that support NDMP Version 4. If a NAS server supports NDMP Version 3, the volumes are automatically enumerated.

More information:

[File System Configuration](#) (see page 22)

Supported NAS Backup Configurations

CA ARCserve Backup supports NAS local and three-way NDMP backups.

NAS Local NDMP Backups

If a NAS server has a locally-attached tape device, CA ARCserve Backup can trigger a serverless backup of the NAS server's data to this device.

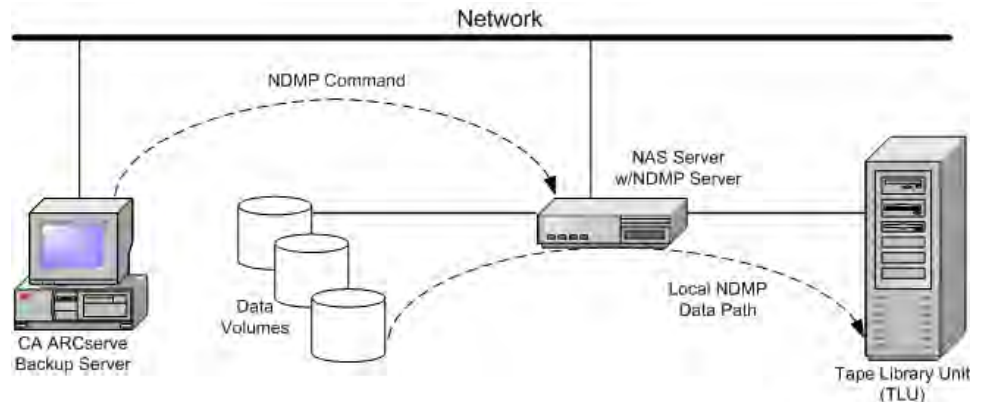

NAS Three-way NDMP Backups

Some NAS servers on the network may not have tape devices attached to them. As long as at least one NAS server has an attached tape device, that device can be used when backing up other NAS servers.

Example: NAS Three-way NDMP Backup

NAS Server 1 does not have a tape device attached to it, but NAS Server 2 does. The NDMP NAS Option can back up NAS Server 1's data to the tape device attached to NAS Server 2. This configuration is known as NAS three-way NDMP backup.

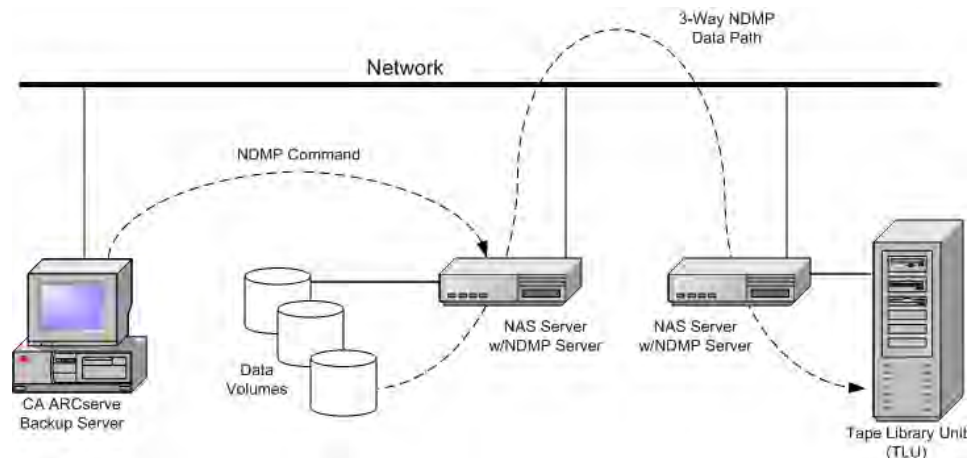

How the Option Backs Up Data

CA ARCserve Backup gives you great flexibility in specifying options, filters, and scheduling information for your jobs. You can use the Backup Manager to configure and to submit a backup job for data in your network. Choose any NAS server as your source and a tape device connected to a NAS server as your destination.

When you back up data from a file system, the Network Appliance NAS server creates a snapshot of that data set so that the backup reflects a consistent view of the data at the time of the backup. The data is then indirectly backed up from this snapshot.

Important! You can use NDMP NAS Option when you need to back up data stored on a NAS server to a tape device that is connected to either the same NAS server or another NAS server. In either case, the NAS server must support NDMP.

In an environment where a shared backup device on a SAN is connected to the CA ARCserve Backup server and a NAS device, you can use the NDMP NAS Option to back up data directly from the NAS server to the shared device.

For an overall description of the backup features of CA ARCserve Backup, see the *Administration Guide*.

Important! The CA ARCserve Backup functionality available for backing up data depends on the NDMP version implemented and the type of NAS server. For information about vendor-specific restrictions, see the appendix "Feature Support Summary."

More information:

[Supported Backup Features](#) (see page 75)

[Supported General Features](#) (see page 77)

How the Option Restores Data

To restore data from a tape device to a NAS server, use the Restore Manager to configure and to submit the job. For an overall description of the restore features, see the *Administration Guide*.

The CA ARCserve Backup functionality available for restoration of data depends on the NDMP version implemented and the type of NAS server. For information about vendor-specific restrictions, see the appendix, "Feature Support Summary."

The following diagram shows an example of a local restore:

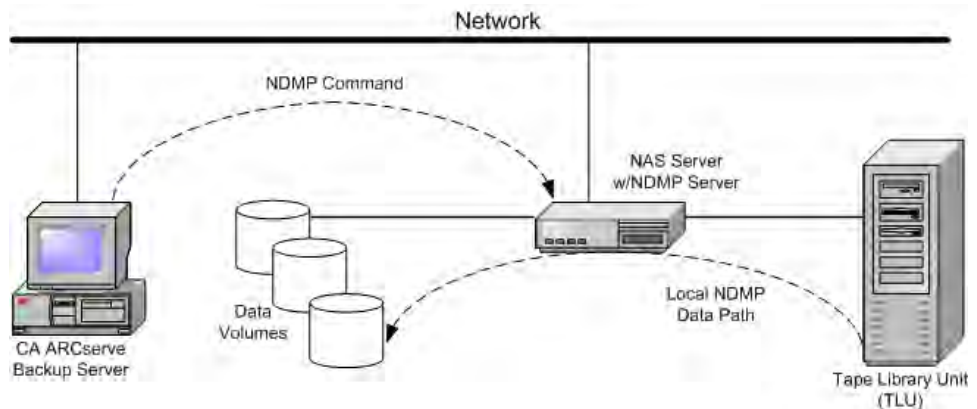

The following diagram shows an example of a three-way restore:

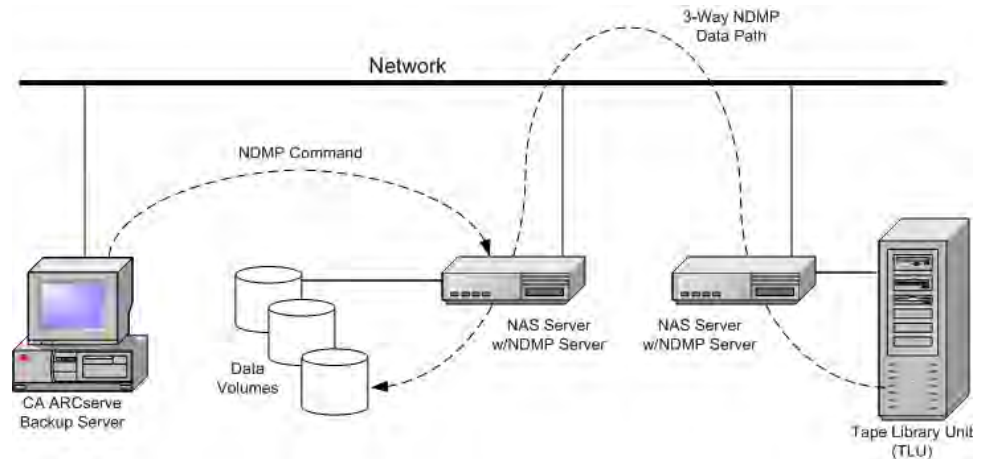

More information:

[Supported Restore Features](#) (see page 78)

[Supported General Features](#) (see page 77)

Restore by Source

You can view NAS servers by clicking the Source tab of the Restore Manager. You can select individual NAS files or directories for recovery, as you can for other types of hosts or clients supported by CA ARCserve Backup.

Restore by Destination

Because NAS backups are third-party backups, they use the NAS vendor's proprietary format. Although most NAS servers use NDMP, it is advisable to perform backup and restore operations to the same vendor's type of server. Furthermore, you cannot restore the NAS session if you move the tape to a device locally connected to the CA ARCserve Backup server.

Browsing file or directory selection for restores functions in the same way as browsing NAS servers from the Source tab of the Backup Manager.

Dynamic Device Sharing

Note: To use dynamic device sharing, you must install the following options:

- CA ARCserve Backup Enterprise Module
- SAN Option
- Tape Library Option

In an environment composed of fibre attached storage devices with one or more CA ARCserve Backup servers, complications can arise when exposing devices that reside on the fibre uniquely. Duplication of devices occur when more than one fibre adapter exists to enumerate the devices on a fibre loop. If individual media engines reside on the same SAN, you must collect and organize multiple media engines from a central management application to ensure that these engines integrate seamlessly.

In this case, an NDMP tape server running on a NAS device is considered a media engine. The CA ARCserve Backup tape engine is also considered a media engine. Using this feature will allow them to integrate seamlessly.

When separate fibre adapters exist to enumerate devices on a fibre loop, DDS dynamically manages all duplicate references to a device. DDS gives you more flexibility in choosing how to design your storage topology.

Dynamic device sharing is cost efficient because only one library is needed for backing up NAS and non-NAS data. Additionally, DDS enables:

- Drives and tape library unit (TLU) control to be shared seamlessly between the local CA ARCserve Backup server and the NAS server.
- NAS data to be backed up to the same tape that non-NAS data was backed up to.
- NAS and non-NAS jobs to be multi-streamed and packaged to run together. The optimal data path will be chosen on all backups and restores. All NAS servers can detect the drives and data. This eliminates the need for three-way backups, and only direct two-way data paths will be used for backing up data.

For information about how to configure your system to use DDS, see the section [Dynamic Device Sharing Configuration](#).

Note: DDS does not support restoration of local backups to a NAS server, or NAS server backups to the local CA ARCserve Backup server. This limitation exists because NAS backups are third-party backups, and are written in a format that is proprietary to the NAS vendor.

More information:

[How You Configure Dynamic Device Sharing](#) (see page 30)

Supported DDS Configurations

The NDMP NAS Option supports two fundamental DDS configurations:

- One or more NAS servers connected to the SAN that share a tape drive or TLU, and the CA ARCserve Backup server is connected to the SAN.
- Two or more NAS servers connected to the SAN that share a tape drive or TLU, and the CA ARCserve Backup server is not connected to the SAN.

The following diagram shows an example of one or more NAS servers connected to the SAN that share a tape drive or TLU, and the CA ARCserve Backup server is connected to the SAN.

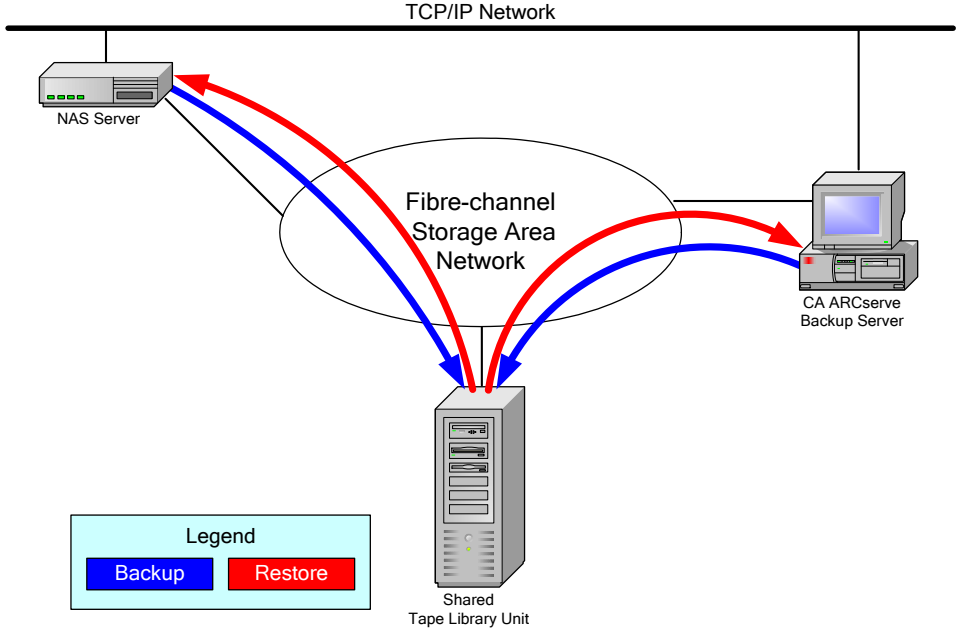

The following diagram shows an example of two or more NAS servers connected to the SAN that share a tape drive or TLU, and the CA ARCserve Backup server is not connected to the SAN.

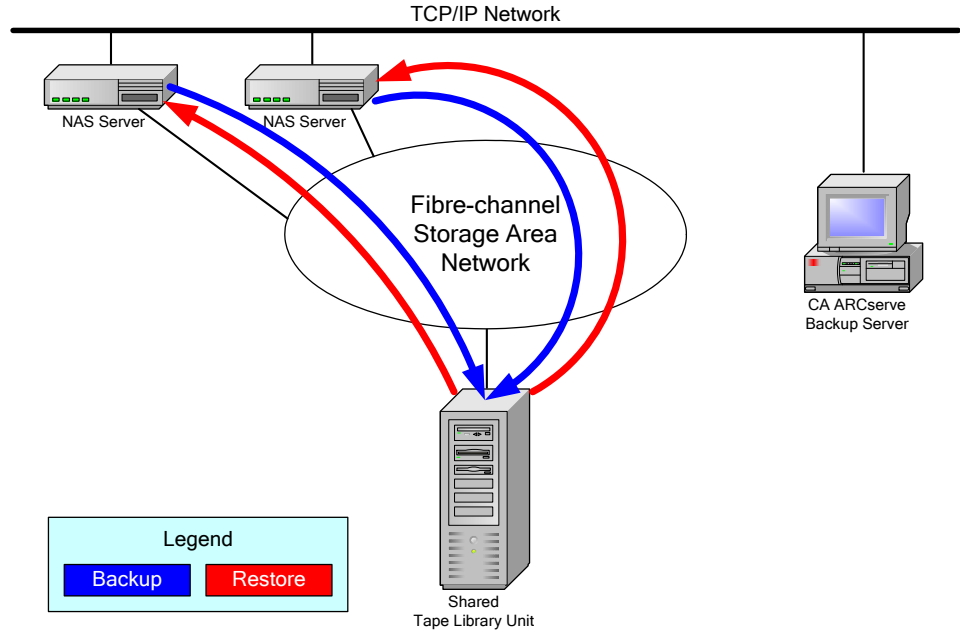

Log Access

The NDMP NAS Option generates the information contained in logs in the <base install>/Logs directory. The available logs and the type of information provided in each log is as follows:

Tape.log

Generated by the Tape Engine, the DDS Device Map section provides information that details whether or not the primary or secondary device reference chosen was optimal.

LibSetup.log

Generated by the CA ARCserve Backup Tape Library Option. This log provides information that details if duplicate device references were detected on all SCSI ports.

Chapter 2: Installing the Option

This section describes how to install and configure the NDMP NAS Option. The information in this chapter assumes you are familiar with the characteristics and requirements of the specified operating systems, and with administrator responsibilities on those operating systems.

This section contains the following topics:

[Installation Prerequisites](#) (see page 21)

[Option Installation](#) (see page 22)

[File System Configuration](#) (see page 22)

[Option Configuration](#) (see page 25)

Installation Prerequisites

If you want to use the NDMP NAS Option, you must first prepare and configure the NAS server, and the CA ARCserve Backup server. Prior to proceeding, verify that:

- Your system meets the minimum hardware and software requirements needed to install the NDMP NAS Option. For a list of requirements, see the readme file.
- The NAS server's operating system is compatible with CA ARCserve Backup. For information about hardware and software requirements for Network Appliance, EMC Celerra, EMC CLARiiON IP4700, and Procom NAS devices, see the Readme.
- CA ARCserve Backup is installed and working properly.
Note: You must install the option on the CA ARCserve Backup server.
- You have administrator rights or the proper authority to install software on the computers where you will be installing the option.
- You know the name and the password of the machine you are installing the option on.
- You have made a note of any changes to the default installation path.

Option Installation

The NDMP NAS Option follows the standard installation procedure for the system components, agents, and options of CA ARCserve Backup. For the detailed steps in this procedure, see the *Implementation Guide*.

After you complete the installation procedure, be sure to restart your computer when prompted.

File System Configuration

The NDMP NAS Option installs a configuration file called `nas.cfg` in the NAS Option folder. This is the file in which you specify the items that are eventually displayed on the Source tab of the Backup Manager. After configuring this file, you can browse the items entered in the Backup Manager.

Configure NDMP Version 3

When a NAS server supports NDMP Version 3, you can configure the `nas.cfg` file for partial-volume backups. The NDMP NAS Option cannot determine volume mappings for these servers. To perform partial-volume backups, you must enter the paths into the configuration file.

To enter the path information

1. Open the `nas.cfg` file located in the `<base install>\NAS` Option folder.
2. On the first line, enter the host name of the NAS server.
3. Enter each absolute path, starting with the logical device name, on separate lines following the host name of the NAS server.
4. Enter a semicolon to end each server configuration.
5. Save the file.

Example: How You Configure the nas.cfg File to Support NDMP Version 3

The example below shows how the nas.cfg file would look if the user wanted to back up a partial volume consisting of database files.

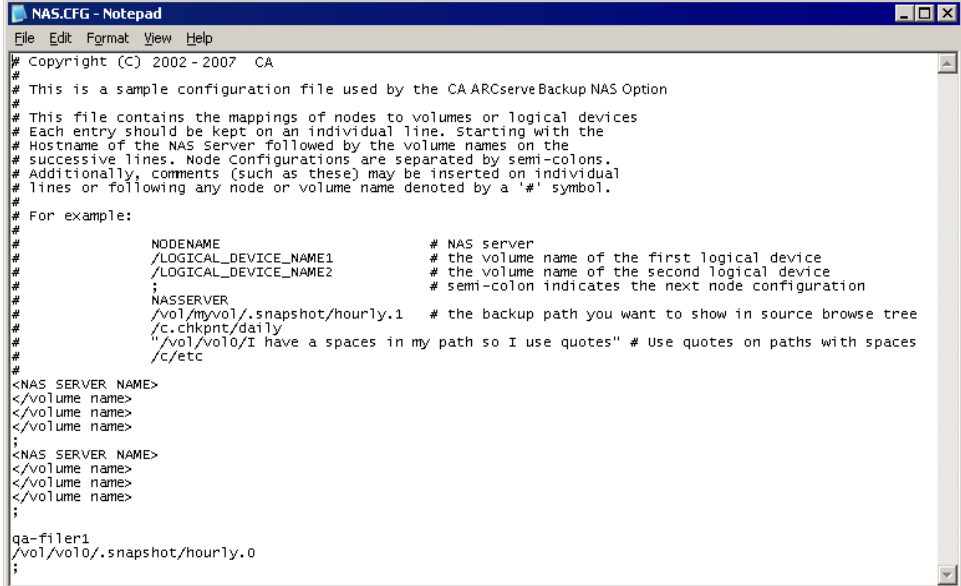

```

NAS.CFG - Notepad
File Edit Format View Help
# Copyright (C) 2002-2007 CA
# This is a sample configuration file used by the CA ARCserveBackup NAS Option
# This file contains the mappings of nodes to volumes or logical devices
# Each entry should be kept on an individual line. Starting with the
# Hostname of the NAS server followed by the volume names on the
# successive lines. Node configurations are separated by semi-colons.
# Additionally, comments (such as these) may be inserted on individual
# lines or following any node or volume name denoted by a '#' symbol.
# For example:
#
#           NODENAME           # NAS server
#           /LOGICAL_DEVICE_NAME1 # the volume name of the first logical device
#           /LOGICAL_DEVICE_NAME2 # the volume name of the second logical device
#           ;                   # semi-colon indicates the next node configuration
#
#           NASSERVER
#           /vol/myvol/.snapshot/hourly.1 # the backup path you want to show in source browse tree
#           /c.chkpnt/daily
#           "/vol/vol10/I have a spaces in my path so I use quotes" # Use quotes on paths with spaces
#           /c/etc
#
<NAS SERVER NAME>
</volume name>
</volume name>
</volume name>
;
<NAS SERVER NAME>
</volume name>
</volume name>
</volume name>
;
qa-filer1
/vol/vol10/.snapshot/hourly.0
;

```

An example of the corresponding Restore Manager window follows:

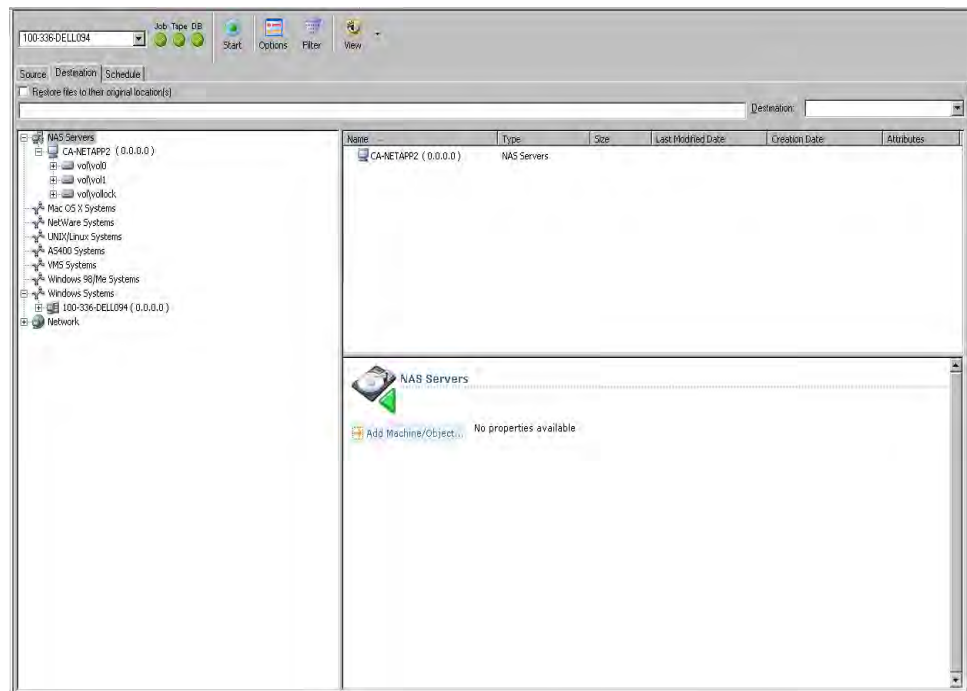

More information:

[Network Data Management Protocol \(NDMP\)](#) (see page 13)

Configure NDMP Version 4

If you are using a NAS server with NDMP Version 4, and support for Snapshot Management Extensions, you do not have to use the nas.cfg file. However, currently only Network Appliance NAS servers support this functionality.

More information:

[Network Data Management Protocol \(NDMP\)](#) (see page 13)

Snapshots and Checkpoints Configuration

A snapshot or a checkpoint is an online, read-only copy of an entire file system that protects against deletions or modifications of files without duplicating file contents. Snapshots enable you to restore files and allow you to back up the files to tape while the NAS server is in use. Snapshots of data on a file system can also be created and scheduled, as needed, by the NAS administrator.

If you are backing up snapshots or checkpoints on your NAS server, you must configure the nas.cfg file. The file would be edited like it was for a partial-volume backup.

The following is an example of the Backup Manager window showing a Network Appliance snapshot called hourly.0 and a checkpoint called daily.

Note: The names of the snapshot files are vendor-specific.

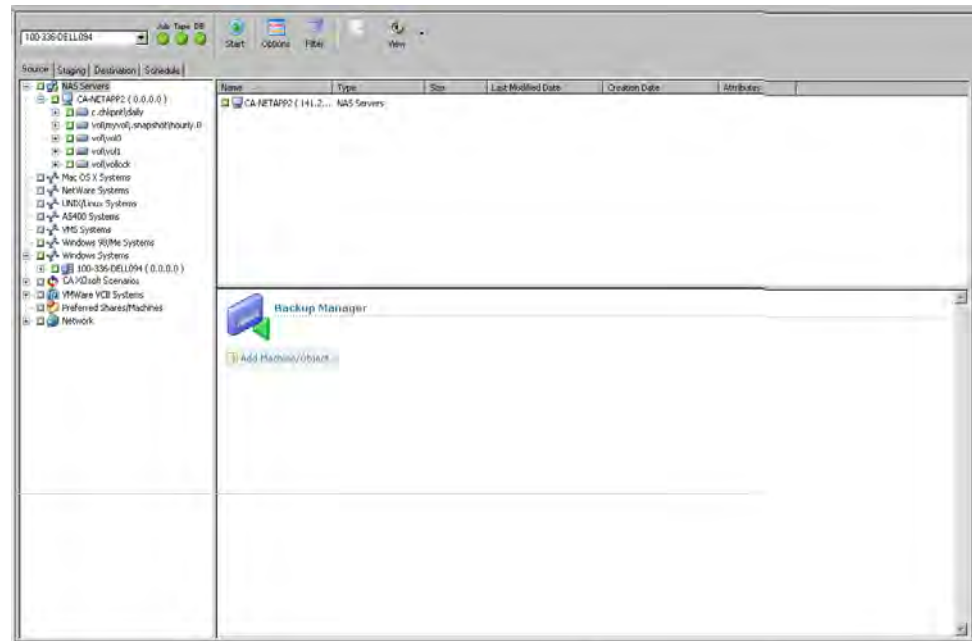

Option Configuration

After you have completed the NDMP NAS Option installation, you must configure the NAS servers, tape drives, or tape library units.

Prior to configuring the devices and drives, confirm the following:

- You can ping or access the NAS server from the server on which the NDMP NAS Option is installed.
- The NAS server being used as the destination for backup data can detect its locally attached drives or tape library units.
- The tape library units and NAS servers are certified by CA.
- The tape drives are certified by the NAS vendors.
- Verify that the tape drive is not already opened and in use by another NDMP session (only one connection is allowed at one time).

Configure NAS Devices

You can configure the NAS drives and tape devices either immediately after you install the NDMP NAS Option or from Device Configuration.

Note: If you are configuring the devices and drives immediately after installation, you can skip to Step 5 of the following instructions.

To configure the NAS devices

1. Select Device Configuration from the CA ARCserve Backup Home Page.
The Device Configuration Welcome screen is displayed.
2. On the Device Configuration Welcome screen, click Next.
The Options dialog is displayed.
3. On the Options dialog, select NAS Servers and click Next.
The NAS Servers Configuration dialog is displayed.
4. Click Add, and Select NAS Server from the drop-down box.

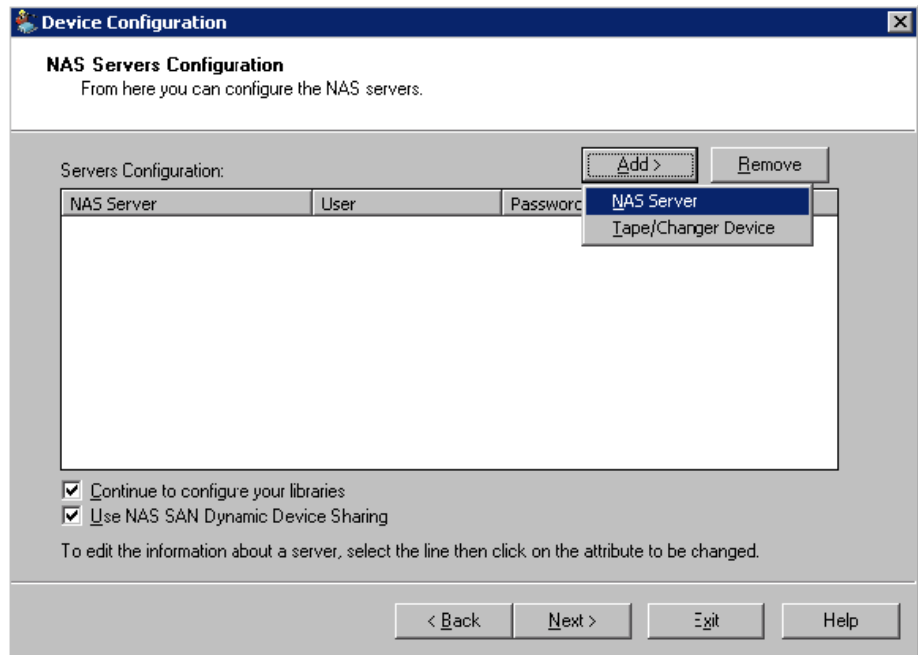

- On the Device Configuration dialog, highlight New Server and enter the name of the NAS server, user name, and password. The user name and password must be associated with a NAS server account with NAS Administrative privileges.

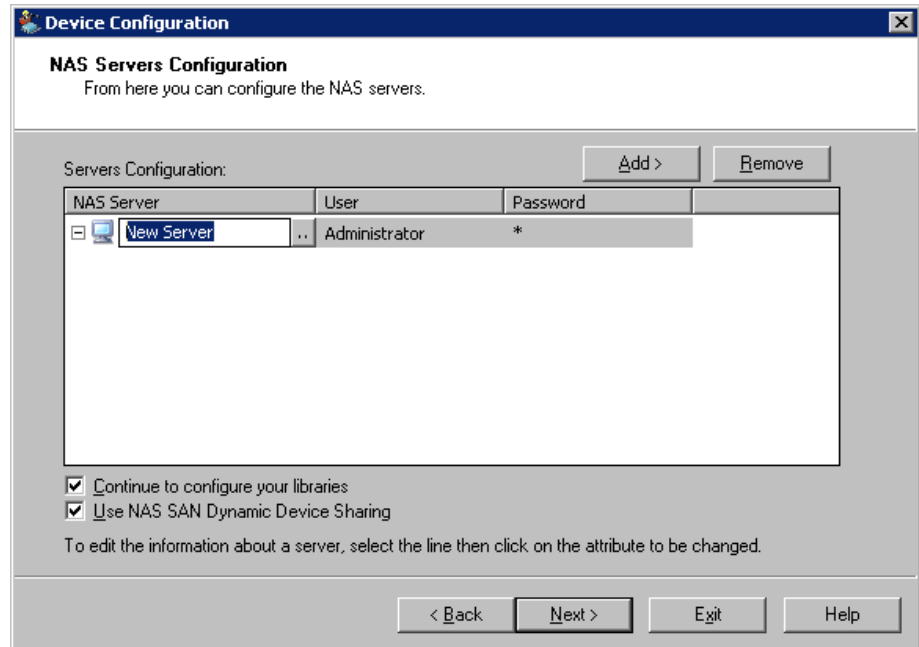

Steps 6 and 7 are optional steps for NAS servers supporting NDMP Versions 3 and 4. NAS servers which are enabled for NDMP Version 3 or Version 4 allow the client to detect backup devices that are configured on the NAS server. The NDMP NAS Option performs this detection and displays all the detected devices. The format and usage rules governing the logical device names differ from one vendor to another. For information about how to determine logical device names, see the vendor-specific appendixes in this guide.

If you are using NDMP Version 3 or Version 4, skip Steps 6 and 7 and continue with Step 8.

- Click Add, and select Tape/Changer Device to enter the tape drive or tape library unit configuration information.

7. Highlight New Tape Device and enter the tape device information.

The information entered on this dialog is typically a logical device name that represents the tape device or tape library unit. A logical device name refers to a unique string that the NAS server or NDMP server uses to refer to the device.

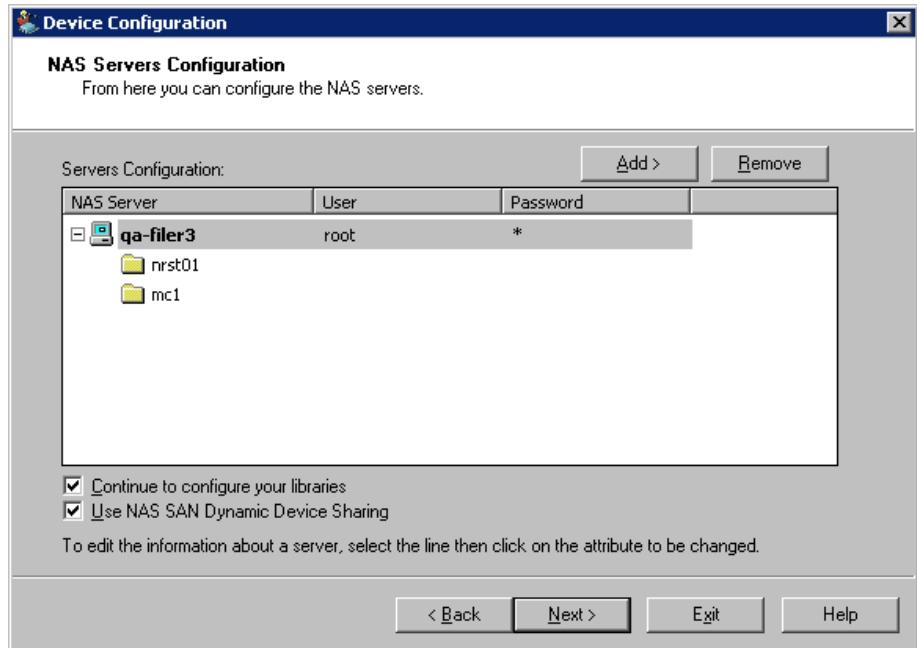

8. Repeat Steps 4 and 5 (and optionally 6 and 7) for all additional NAS servers that you want to configure for use with the NDMP NAS Option. The CA ARCserve Backup server can interact with more than one NAS server over the network.
9. If your environment has one of the following conditions, check the Use NAS SAN Dynamic Device Sharing check box.
 - One or more NAS servers connected to the SAN share a tape drive or TLU, and the CA ARCserve Backup server is connected to the SAN.
 - Two or more NAS servers connected to the SAN share a tape drive or TLU, and the CA ARCserve Backup server is not connected to the SAN.

Note: For more information about these environment conditions, see the section Supported DDS Configurations.

- When you have finished adding all the server and tape devices, clear the Continue to configure your libraries check box, and click Finish. The Device Configuration Completed dialog displays.

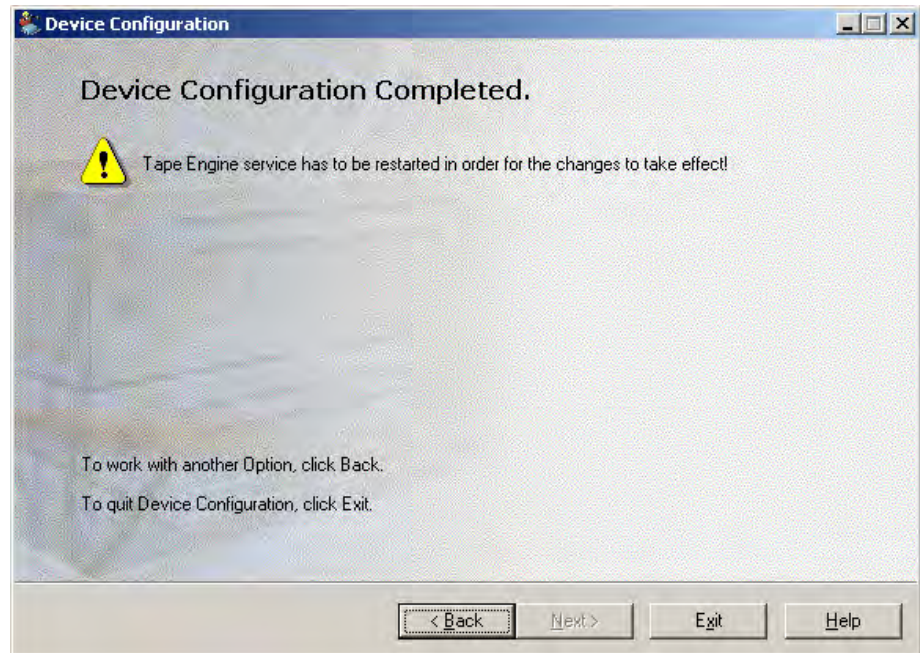

- Click Exit. If you are sure that you want to exit Device Configuration, click Yes.
- Start the Tape Engine.

More information:

[Supported DDS Configurations](#) (see page 19)

How You Configure Dynamic Device Sharing

To configure your system to use DDS

Note: To use dynamic device sharing, you must install the following options:

- CA ARCserve Backup Enterprise Module
- SAN Option
- Tape Library Option

1. Open the fibre switch so that all of the NAS servers and CA ARCserve Backup servers can detect all of the devices and each other.
2. Configure a SCSI bridge or router such that it does not expose itself as a SCSI array device. NAS servers may not be able to connect to the SCSI bridge or router if it exposes itself as an array device.
3. Verify that all NAS and CA ARCserve Backup servers can detect all devices.
4. Ensure that online TLUs are in the ready state.
5. Confirm that devices are shared by enabling the Tape Engine Debug Log in Server Administration when starting the tape engine. This log (labeled tape.log) provides you with details about devices that are shared and not shared. The details can be found in the List Dynamic Device Sharing Device Map section of the Tape Engine Debug Log.

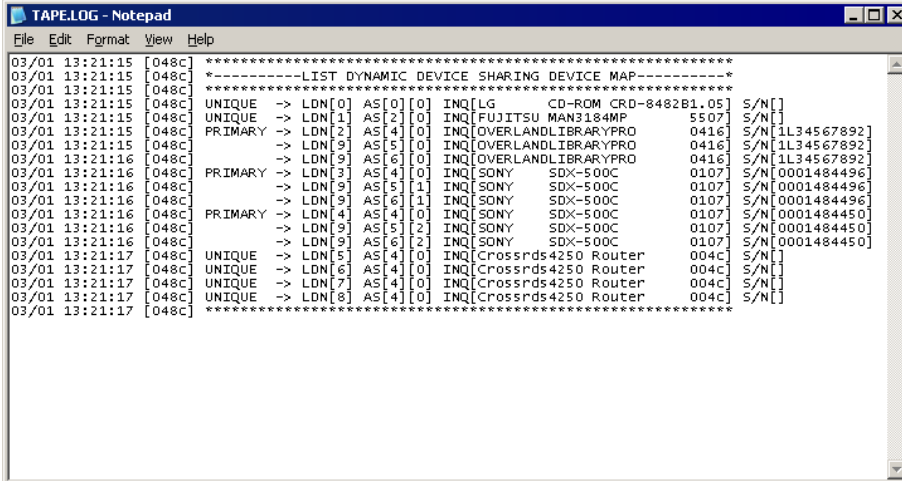

```

03/01 13:21:15 [048c] *****
03/01 13:21:15 [048c] *-----LIST DYNAMIC DEVICE SHARING DEVICE MAP-----*
03/01 13:21:15 [048c] *****
03/01 13:21:15 [048c] UNIQUE -> LDN[0] AS[0][0] INQ[LG CD-ROM CRD-8482B1.05] S/N[ ]
03/01 13:21:15 [048c] UNIQUE -> LDN[1] AS[2][0] INQ[FUJITSU MAN3184MP 5507] S/N[ ]
03/01 13:21:15 [048c] PRIMARY -> LDN[2] AS[4][0] INQ[OVERLANDLIBRARYPRO 0416] S/N[1L34567892]
03/01 13:21:15 [048c] -> LDN[9] AS[5][0] INQ[OVERLANDLIBRARYPRO 0416] S/N[1L34567892]
03/01 13:21:16 [048c] -> LDN[9] AS[6][0] INQ[OVERLANDLIBRARYPRO 0416] S/N[1L34567892]
03/01 13:21:16 [048c] PRIMARY -> LDN[3] AS[4][0] INQ[SONY SDX-500C 0107] S/N[0001484496]
03/01 13:21:16 [048c] -> LDN[9] AS[5][1] INQ[SONY SDX-500C 0107] S/N[0001484496]
03/01 13:21:16 [048c] -> LDN[9] AS[6][1] INQ[SONY SDX-500C 0107] S/N[0001484496]
03/01 13:21:16 [048c] PRIMARY -> LDN[4] AS[4][0] INQ[SONY SDX-500C 0107] S/N[0001484450]
03/01 13:21:16 [048c] -> LDN[9] AS[5][2] INQ[SONY SDX-500C 0107] S/N[0001484450]
03/01 13:21:16 [048c] -> LDN[9] AS[6][2] INQ[SONY SDX-500C 0107] S/N[0001484450]
03/01 13:21:17 [048c] UNIQUE -> LDN[5] AS[4][0] INQ[Crossrds4250 Router 004c] S/N[ ]
03/01 13:21:17 [048c] UNIQUE -> LDN[6] AS[4][0] INQ[Crossrds4250 Router 004c] S/N[ ]
03/01 13:21:17 [048c] UNIQUE -> LDN[7] AS[4][0] INQ[Crossrds4250 Router 004c] S/N[ ]
03/01 13:21:17 [048c] UNIQUE -> LDN[8] AS[4][0] INQ[Crossrds4250 Router 004c] S/N[ ]
03/01 13:21:17 [048c] *****

```

6. Verify that the tape drive is not already opened and in use by another NDMP session.

Note: Shared SCSI devices will show up under the local adapter. The group and adapter icon will be marked as shared.

Configuring your system to use DDS presents the following restrictions:

- If the CA ARCserve Backup SAN Option is installed, the NDMP NAS Option must be installed on the primary backup server.
- The SAN must allow all member servers to detect attached backup devices.
- DDS does not function in a cross-platform environment.
- NAS servers must meet all of the vendor requirements by using certified devices and equipment to function properly and individually on the SAN.

Enable DDS Using Device Configuration

To enable DDS using Device Configuration

1. Select the Use NAS SAN Dynamic Device Sharing check box on the NAS Servers Configuration dialog of Device Configuration.

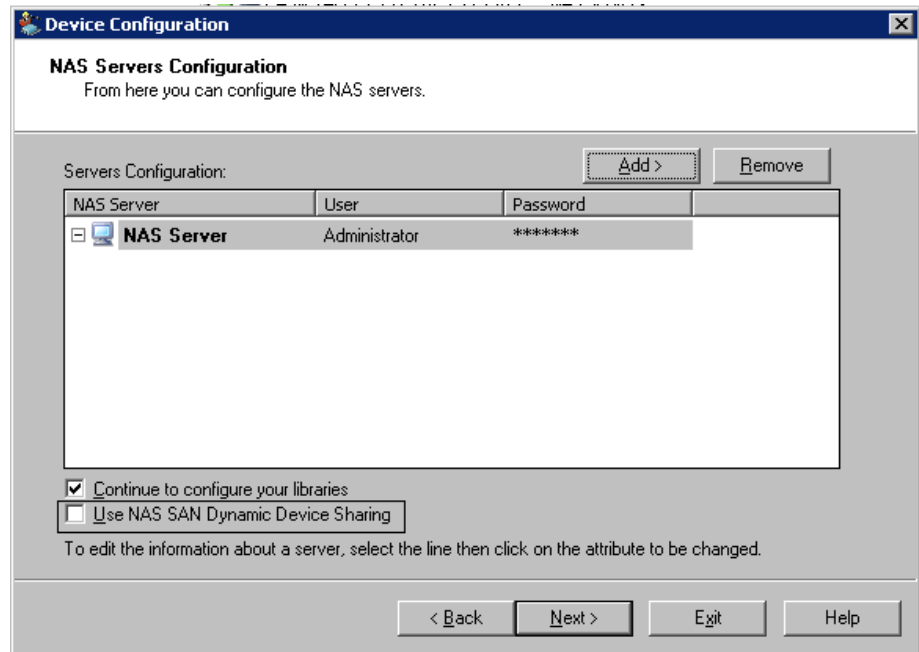

2. Click Next to continue to the next NAS Servers Configuration dialog.

How You Can Identify Dynamically Shared Devices

There are several methods that you can use to identify dynamically shared devices.

Device Manager directory tree

The directory tree of the Device Manager window identifies dynamically shared devices with the icon shown in the following example. This example represents one dynamically shared changer with six drives.

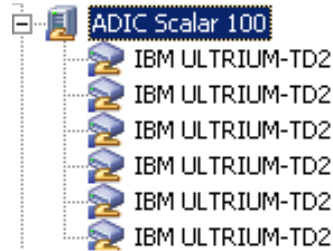

Device Manager Properties pane

If a device is dynamically shared, you can view summary and detail information about the shared device in the Properties pane in the Device Manager window.

The Summary tab for a dynamically shared device is shown in the following example:

Summary		Details
Device Information		
Vendor	ADIC	
Product Name	Scalar 100	
Firmware Version	2.62	
SCSI Compliance	SCSI-III	
Serial No.	1JSV20053A	
Device Configuration		
Description	Device:1=Board:2,Bus:0,SCSI ID:0,LUN:0	
This is a shared device connected to NAS.		
Shared by	100-336-DELL094	
Shared by	CA-NETAPP2	

Chapter 3: Using the Option

This section shows you how to perform backup and restore operation using the NDMP NAS Option. For detailed information about backing up and restoring data, see the *Administration Guide*.

This section contains the following topics:

[How You Manage Backup Operations](#) (see page 33)

[How You Manage Restore Operations](#) (see page 40)

[How You Manage Devices and Media](#) (see page 47)

[How You Manage the Database and Reports](#) (see page 48)

[How You Manage NAS Operations Using CA ARCserve Backup Utilities](#) (see page 48)

How You Manage Backup Operations

To back up data from your network, use the Backup Manager to configure and submit a backup job. You can use any NAS server as your source and a tape device connected to either the same NAS server or another NAS server as your destination. Although all NAS servers use NDMP, it is advisable to perform backup and restore operations to the same vendor's type of server.

When you select a NAS server for a backup, a customized set of standard CA ARCserve Backup options is available. The version of NDMP in use on the NAS server causes some of the standard options not to be available. The unavailability of other options results from limitations of a vendor's particular server.

Backup Options

When a NAS server is selected for a backup, a customized set of standard CA ARCserve Backup options are available. Some of the standard options are not available due to the version of NDMP in use on the NAS server. Other options are not available due to the limitations of a vendor's particular server.

For instance, CA ARCserve Backup does not support backing up multiple folders from the same volume as part of the same job on most NAS servers. You can select individual folders as part of separate jobs and schedule them to run concurrently. If you specify multiple folders, CA ARCserve Backup recognizes only the first folder in a volume and ignores the rest of the folders specified.

NDMP version 3 does not support multi-byte or Unicode names. This can cause the granularity of the backup session's restore view to be reduced.

Network Appliance NAS servers, however, enable you to back up multiple files and folders in a single volume.

For a more complete listing of vendor-specific NAS server limitations, see the appendix, "Feature Support Summary."

More information:

[Supported Backup Features](#) (see page 75)

[Supported General Features](#) (see page 77)

Backup Prerequisites

Before you start a backup job, check the following:

- You are using the correct user name and password for security logins on the NAS server.
- You see the NAS devices in the Device Manager window.
- You can browse the NAS sever in the respective source and destination trees of the Backup Manager and Restore Manager.
- If you are backing up a snapshot or checkpoint, make sure the server is configured to create these files.
- Make sure the tape drives are certified by the NAS vendor.
- Make sure the tape library unit and the NAS server are certified by CA.

Add a NAS Server

To add a NAS server

1. On the Backup Manager Source tab, right-click NAS Servers in the displayed tree.
2. Select Add Machine/Object.

3. In the Add Server dialog that appears, enter the Host name and IP address. In the absence of an IP address, you should check the Use Computer Name Resolution box.

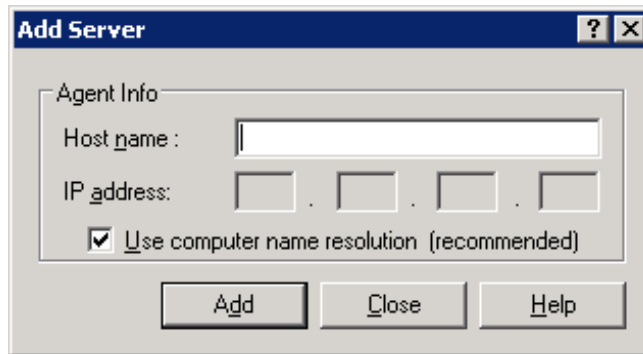

4. Click Add to register the server.

Note: CA ARCserve Backup prompts you to enter security information when you attempt to browse or expand the NAS server that you just added.

For Network Appliance NAS servers that support the NDMP Version 4 Snapshot Management Interface Extension, CA ARCserve Backup enumerates the volumes, directories, and files on the NAS server. When using Network Appliance servers, you can select more than one subtree per volume. Other NAS vendors are limited to one selection per volume. For NAS servers that support NDMP Version 3, CA ARCserve Backup can automatically enumerate all the volumes that are defined on the NAS server.

More information:

[Option Configuration](#) (see page 25)

[Snapshot Configuration](#) (see page 54)

Back Up a NAS Server

This section describes how to submit a job to back up a NAS server.

To back up a NAS server

1. Open the Backup Manager and expand a NAS server on the Source tab.

This displays the volumes on the server, as illustrated by the following:

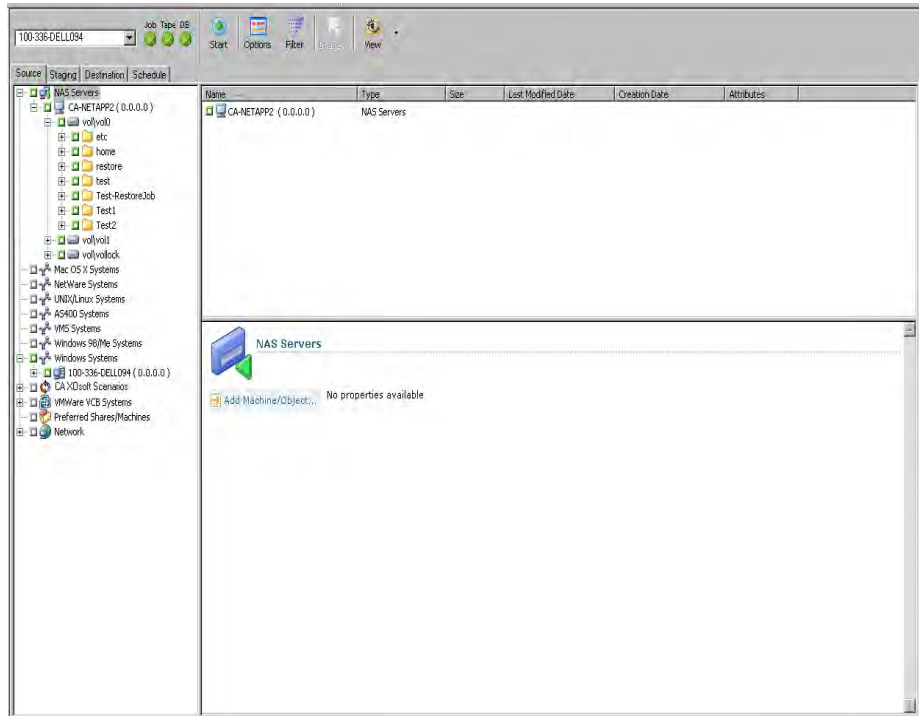

Note: CA ARCserve Backup supports backing up individual NAS server volumes, as well as an entire machine.

2. Select the volumes for backup and click the Destination tab.
3. From the list of available devices, select the device that you want to use for the backup.

Note: You cannot back up a NAS server to a tape drive that is connected to the local CA ARCserve Backup server. Also, you cannot select agents or the local file system on a CA ARCserve Backup server and back them up to a tape drive connected to the NAS servers.

4. Select the Schedule tab

Select the desired Repeat Method from the drop-down list, as illustrated by the following:

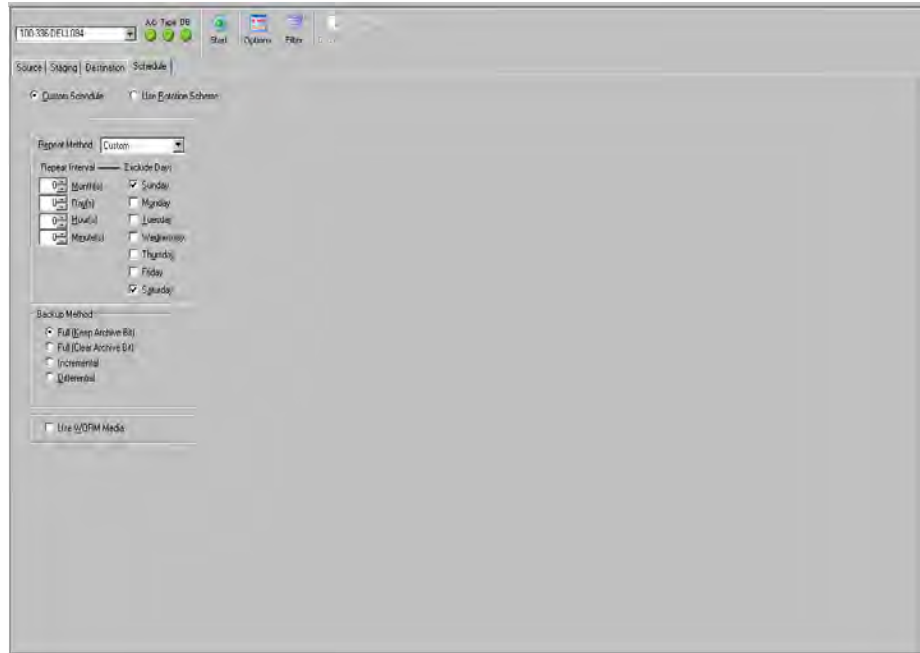

5. Check the Backup Method from the list and click the Start button.

The Security and Agent Information dialog opens as illustrated by the following graphic:

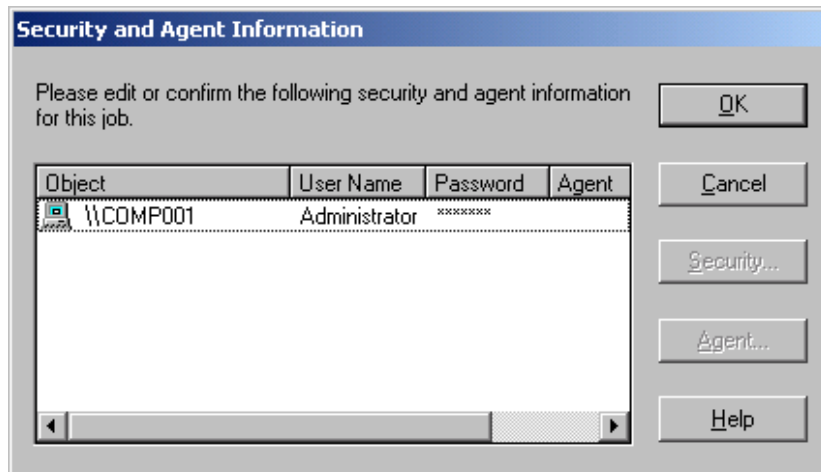

6. Edit the information, or click OK.

The Submit Job dialog opens as illustrated by the following graphic:

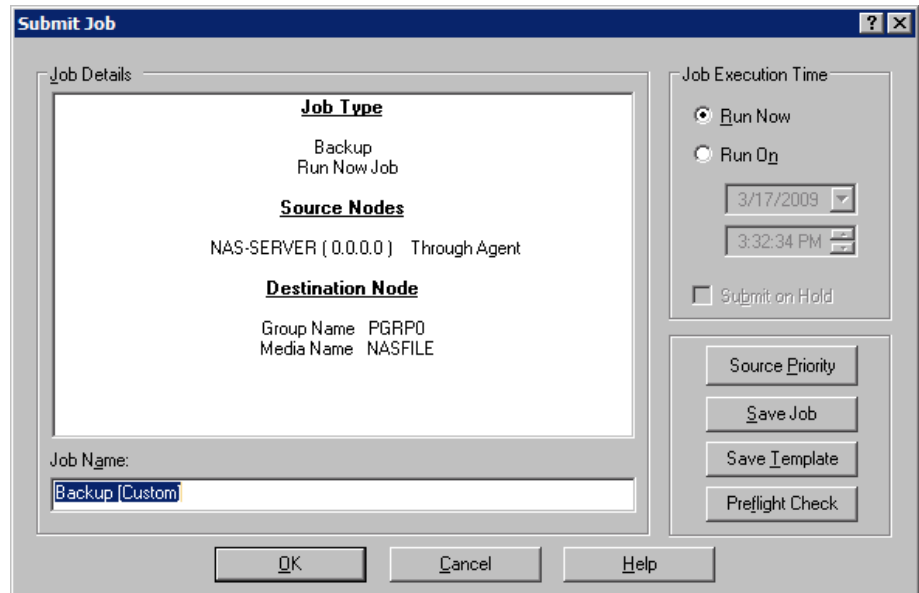

7. Select one of the following Job Execution Time options:

Run Now

The backup starts immediately.

Run On

Input the date and time to start the backup.

Note: For more information about saving jobs and job templates, see the *Administration Guide*.

8. Click OK.

You have successfully submitted the backup job.

After submitting the backup job, you can monitor its progress by opening the Job Status Manager from the CA ARCserve Backup Home Page.

CA ARCserve Backup does not display a progress bar or percentage complete statistic in its Job Monitor when backing up EMC CLARiiON IP4700, Celerra, and Procom NAS servers.

Note: Even though all NAS servers use NDMP protocol, you should perform backups and restores to the same vendor's servers or compatible hosts.

Perform a Staging Backup of a NAS Server

This section describes how to submit a staging job to back up a NAS server.

To perform a staging backup of a NAS server

1. Open the Backup Manager, click the Source tab, and expand a NAS server.

The volumes on the server are displayed.

2. Select the volumes for backup and click the Staging tab.
3. On the Staging tab, check the Enable Staging check box and select the staging group that you want to back up.

Note: The staging group has to be dynamically shared between the CA ARCserve Backup Server and the NAS filer.

4. Click the Policy button and from the Staging Policy dialog, specify the staging policies you want applied.

Note: For more information about the Staging Policy options, see the Administration Guide.

5. Click the Destination tab and select the destination for the staging backup job.

You can either select another NAS group or to the same NAS group if it has more than one drive.

6. Click the Schedule tab and set the repeating rate.

If you have more than one drive in each group, the repeating job can be submitted as every 5 minutes. If you only have one drive in each group, the repeating rate can be longer.

7. Click the Start toolbar button to submit the staging backup job.

How You Can Archive Data on the NAS Server

You can only use the NDMP NAS Option to archive the data on the NAS server to its locally attached tape device or to another NAS server with an attached tape device. If the data on the NAS server needs to be backed up to the device on the CA ARCserve Backup server, you can use the Preferred Shares to back up the NAS sever.

Note: To allow CA ARCserve Backup to connect to Network Appliance servers through Preferred Shares, you must create an ADMIN\$ share for the volume containing the /ETC folder on the NAS server. Additionally, you should not back up NAS devices through Preferred Shares, as it does not utilize the NAS-attached backup device or the NDMP protocol for proper NAS operating system backup procedures.

CA ARCserve Backup supports archiving and restoring data from a NAS server to its locally attached tape device and to a tape device attached to another NAS server. However, for non-NAS servers, you can archive data from the server to the tape device connected to the NAS server only if the backup device is shared.

More information:

[Supported DDS Configurations](#) (see page 19)

How You Manage Restore Operations

To restore data from a NAS server, use the Restore Manager for configuring and submitting the job. You can restore data from the tape device attached directly to the local NAS server or from a tape device attached to a different NAS server.

The *Administration Guide* provides a description of the CA ARCserve Backup restore features. However, NAS server restores create some limitations for the normal functionality of CA ARCserve Backup. Some of these result from the NDMP protocol, while others result from limitations imposed by particular NAS servers.

Restore Options

When a NAS server is selected for a restore job, the CA ARCserve Backup options are global options that apply to all restore jobs in general. Options default to overwrite mode for restore jobs. You should be very careful when picking your restore location.

Some of the standard restore options are not available for all NAS servers. Some of the limitations are due to the version of NDMP in use on the NAS server while other limitations are due to the vendor's equipment. For a complete list of vendor-specific NAS server limitations, see the appendix, "Feature Support Summary."

More information:

[Supported Restore Features](#) (see page 78)

[Supported General Features](#) (see page 77)

Restore Methods

You can select the NAS files and directories for recovery or the NAS backup server and individual files and directories. After these files are selected for recovery, you must specify the destination and then start the restore operation.

More information:

[NAS Restore Job Limitations](#) (see page 46)

Restore by Tree

NAS servers are listed on the Source screen. You can select individual NAS files and directories for recovery.

The following screen shows the Source tab with the directories of one server expanded:

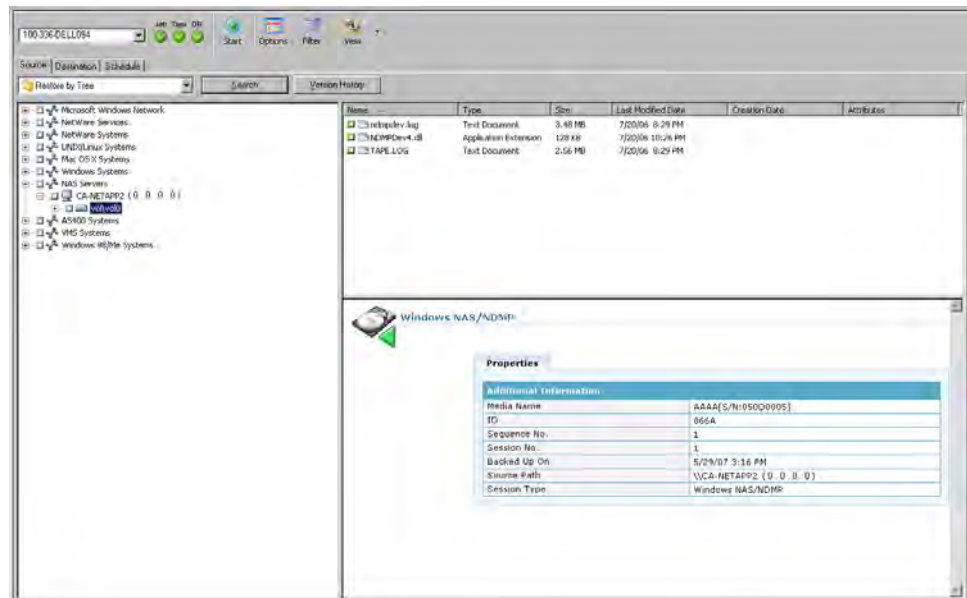

To restore by tree

1. Select Restore by Tree.
2. Select the files or directories you want to restore.
3. Click the Start toolbar button to submit the restore job.

More information:

[Start the Restore Job](#) (see page 43)
[NAS Restore Job Limitations](#) (see page 46)

Restore by Session

You can use the Restore by Session function to restore NAS server backup sessions and individual files and directories.

The following window shows the Source tab listing the NAS sessions available for restore.

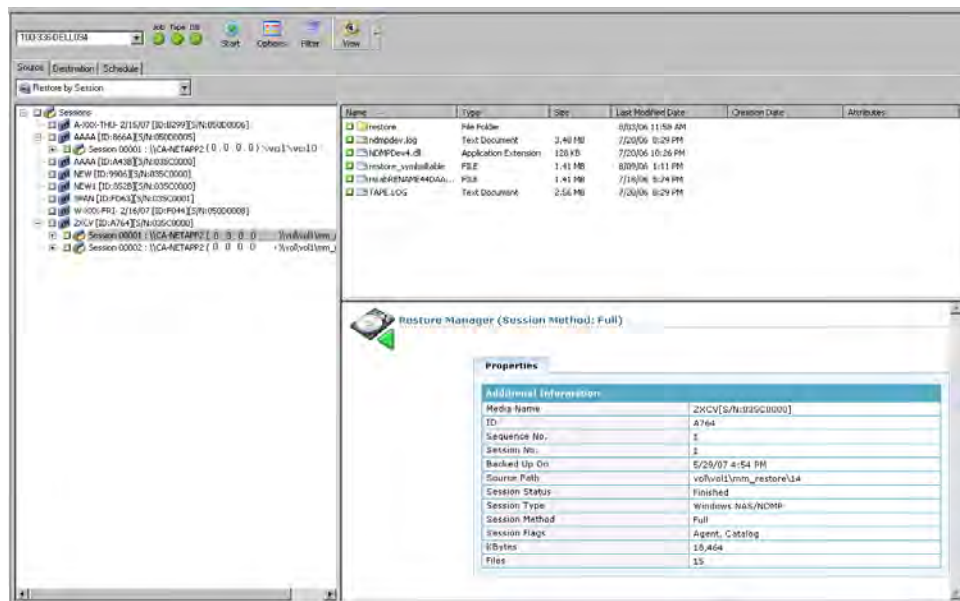

To restore by session

1. Select Restore by Session.
2. Select the session or files that you want to restore.

More information:

[Start the Restore Job](#) (see page 43)
[NAS Restore Job Limitations](#) (see page 46)

Start the Restore Job

This section describes how to submit a job to restore NAS server data.

To start the restore job

1. Select the Destination tab.
2. Select the file system path for the restore as illustrated by the following graphic.

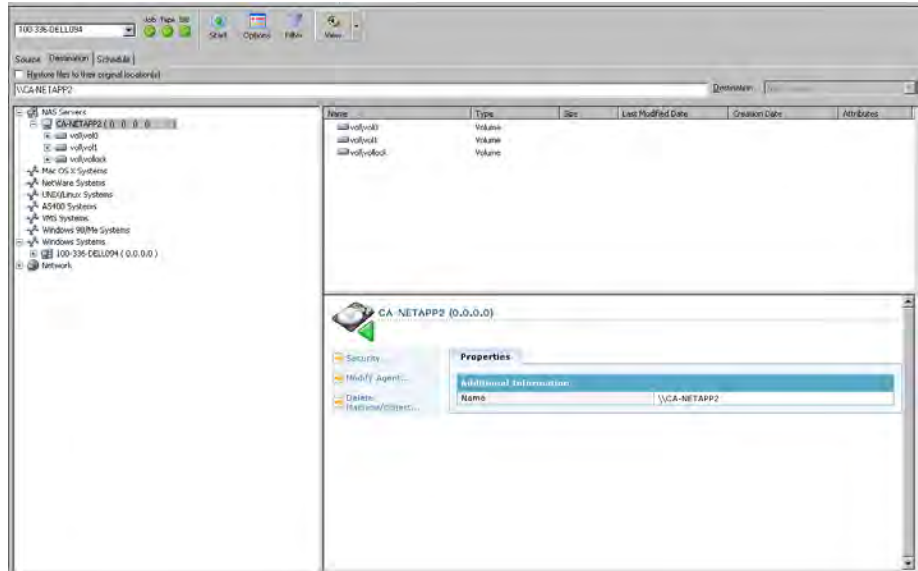

- From the Global Options dialog, select a supported restore option as illustrated by the following graphic:

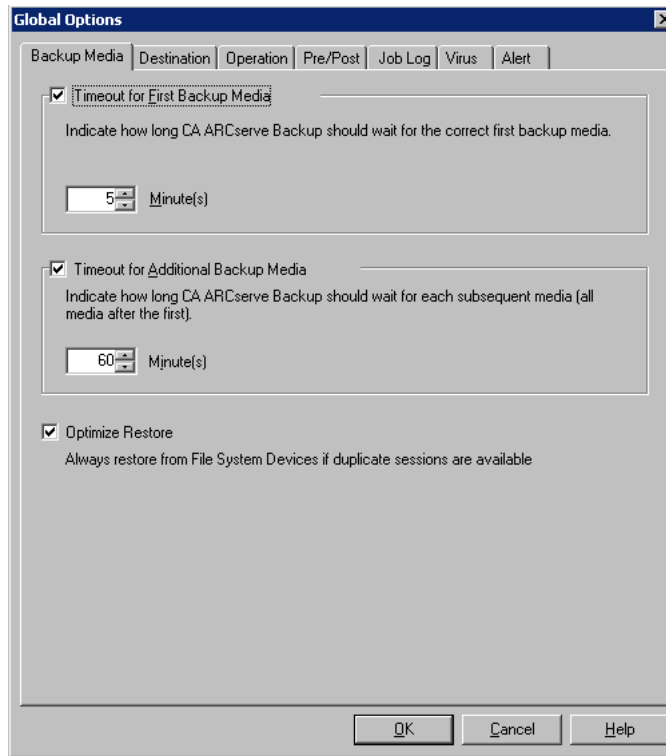

Click OK.

- Click the Start button.

The Session User Name and Password dialog opens as illustrated by the following graphic:

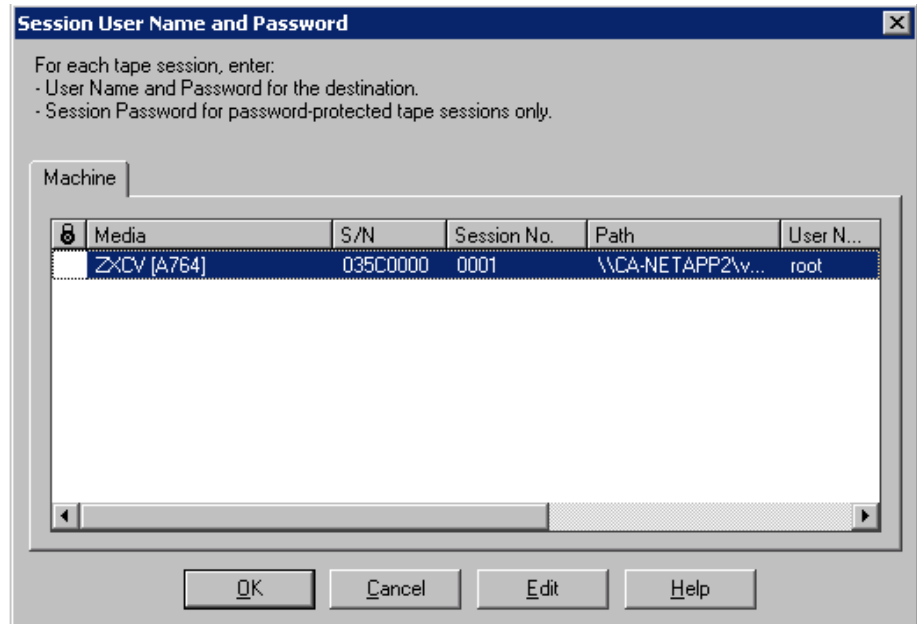

- Edit the information or click OK.

The Submit Job dialog opens as illustrated by the following graphic:

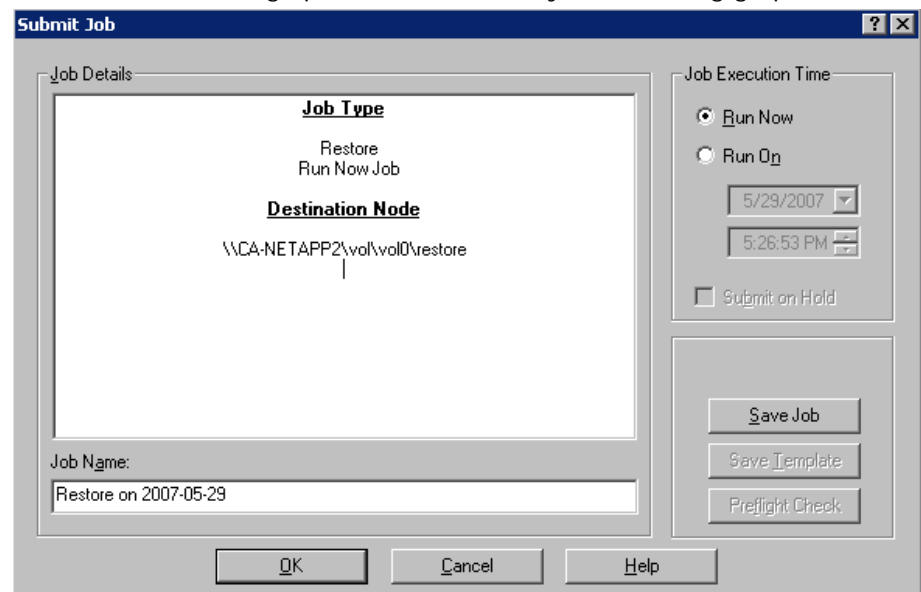

6. Select one of the following Job Execution Time options:

Run Now

The restore starts immediately.

Run On

Input the date and time to start the restore.

Note: For more information about saving jobs and job templates, see the *Administration Guide*.

7. Click OK.

You have successfully submitted a job to restore the data.

After submitting the restore job, you can monitor its progress by opening the Job Status Manager from the CA ARCserve Backup Home Page.

CA ARCserve Backup does not display a progress bar or percentage complete statistics in its Job Monitor when restoring EMC CLARiiON IP4700, Celerra, and Procom NAS servers.

Note: Even though all NAS servers use NDMP protocol, you should perform backups and restores to the same vendor's servers or compatible hosts.

More information:

[NAS Restore Job Limitations](#) (see page 46)

NAS Restore Job Limitations

The following are limitations governing NAS recovery jobs:

- You can restore NAS server data to the original or to a different NAS server.
- You cannot restore to the CA ARCserve Backup server, because it is not an NDMP server.
- You cannot restore to the original location with a snapshot or checkpoint. These are read-only copies of the file system.
- For snapshot sessions, you must use the default restore options. The Do not create base directories option should be selected.
- You can specify a directory path for restore. When you manually specify a destination path on the restore Destination tab, you can browse to select a restore destination, or enter the path to the restore destination using following format:

```
\\TEST\vol\vol0\destination
```
- When restoring using extract-restore mode, the original backup path will be appended to the path specified in the restore destination tree.

- If the tape library or tape library unit and the NAS vendor support Direct Access Restore (DAR), and you are restoring files, the original path will only be appended to the user-specified destination path if the restore options designate that behavior.

DAR supports file restoration only. If you choose to restore at least one folder, the restore reverts to scanning the session.

Note: Extract-restore mode scans the entire contents of a backup image to restore an item. Conversely, DAR traverses to the proper offset.

- The following limitations affect all restores on all NAS vendor appliances:

Note: The following options appear on the Destination tab of the Restore Manager, Global Options dialog.

- When performing non-DAR restore operations, the NDMP NAS Option only supports the “Create Entire Path from the Root” Directory Structure option.
- The NDMP NAS Option does not support the “Do Not Create the Base Directories” Directory Structure option.

How You Manage Devices and Media

The Device Manager gives you information about storage devices that are connected to your network, the media in these devices, and the status of these devices. You can also use the Device Manager to manage the tape drives and media attached to NAS servers.

Adapter, Device, and Group Views

The Device Manager shows adapter, device, and group information about tape devices attached to the NAS servers. This information updates after you run Device Configuration to configure devices attached to NAS servers and then restart the Tape Engine.

Media Management

You can manage media by using the Device Manager to erase, format, and eject media from tape devices attached to NAS servers. The option also supports tape library units and all the media management functionality associated with it.

How You Manage the Database and Reports

CA ARCserve Backup stores backup job information for each backup job you run, including media and media device information, in the CA ARCserve Backup database. You can use this information to perform intelligent restores by keeping track of each file and directory that you backed up to a specific media. When you want to restore a specific file, the database determines where the file is stored. For more information about the database, see the *Administration Guide*.

The information stored in the database can be used for many types of reports. You can access these reports with the Report Manager. The Report Manager provides several functions to help manage both reports and logs. For more information about reports, see the *Administration Guide*.

How You Manage NAS Operations Using CA ARCserve Backup Utilities

CA ARCserve Backup offers several utilities that you can use to manage files. The utilities supported by the NDMP NAS Option include the Copy, Count and Purge utilities. These utilities do not, however, use NDMP to complete their tasks. The NAS servers for these utilities are accessed through the Microsoft network tree.

Note: The Compare utility is not supported for sessions backed up using the option because the backup image is a third-party format.

Merge Utility

Using the Merge utility, you can merge information from media attached to the NAS server into the CA ARCserve Backup database. The information from the media is appended to the existing database files. You can also use the Merge utility to restore data from a CA ARCserve Backup host that is different from the host used to create the backup.

Media Assure & Scan Utility

You can scan the NDMP NAS Option media for information about previously backed-up sessions with the Media Assure & Scan utility.

NAS sessions, by contrast, are third-party backups with content that cannot be interpreted by the Media Assure & Scan utility. The operation is limited to reporting the session-level details of the NAS session. You can also view the results of the media scan in the Report Manager under the Activity Log listing or under the User Log listing (if an additional log file is created). Furthermore, you can select a specific session or scan the entire media for session-level details.

Appendix A: Using Network Appliance NAS Devices

This appendix contains information about how to configure and use Network Appliance NAS devices with the NDMP NAS Option.

This section contains the following topics:

[Network Appliance Servers Configuration](#) (see page 51)

[Option Limitations on Network Appliance Devices](#) (see page 56)

Network Appliance Servers Configuration

Before the NDMP NAS Option can use a Network Appliance server, you must set certain parameters on the NAS server. You can specify most of these server settings from the NAS server's web-based Administrative Interface or from any Telnet console.

Access the Administrative Interface

To access the web-based administrative interface

1. Open a browser window and enter the following URL in the address bar:

```
http://<IP address of the Netapp server>/na_admin/
```

You can also use Telnet to access the system by entering:

```
c:/> telnet <IP address of the NetApp>
```

2. Enter the administrator name and password to log in.

View the Netapp System Log

To view the Netapp System Log

1. Go to `http://<BABserver>/na_admin`.
2. Log in to the server.
3. Choose Server View.
4. Select System Log messages.
5. Check the approximate time of the problem.

User Accounts

The Network Appliance Data ONTAP operating system supports a system account named root. You can also configure optional administrative user accounts to control a server using a Telnet session on the server console, or the server's web-access site.

Enable NDMP on Network Appliance Devices

Network Appliance requires that you enable NDMP on the NAS server. To enable NDMP on the NAS server, you can use the web-based Administrative Interface or the Telnet session as described in the following sections.

To enable the NDMP protocol using the web-based Administrative Interface

1. Open the NAS server URL. For example:
`http://<NAShostname>/na_admin`
(Replace NAShostname with the real NAS host name.)
2. A menu bar appears on the left side of the page. Expand the NDMP section.
3. Select Enable/Disable.
4. Make sure that NDMP is enabled.

To enable the NDMP protocol using Telnet

1. Connect to the Network Appliance server.
2. Enter the command:
`ndmpd status`
This command shows if the NDMP status is on or off.
3. If the NDMP status is off, enable NDMP by entering the following command:
`ndmpd on`

Configure Tape Library Device Names

For the NDMP NAS Option to be able to perform backup and restore operations on a Network Appliance server, the backup devices must be configured properly. Part of the configuration process involves identifying the logical device names of the attached tape library devices. You only need to do this if you have a tape library attached to the NAS server.

To configure tape library device names

1. Activate a Telnet session to issue commands on the server.
2. Enter the following command:

```
sysconfig -m
```

The name of the tape logical unit displays.

Configure the Drive Access Path

The drive access path is the path that Network Appliance servers use to communicate with NDMP drives.

To find and configure the drive access path

1. Use either a Telnet session or the URL: `http://<NAShostname>/na_admin` to connect to the server.
2. Enter the following command to display all the tape device access path information:

```
sysconfig -t
```

This displays all of the tape access path information:

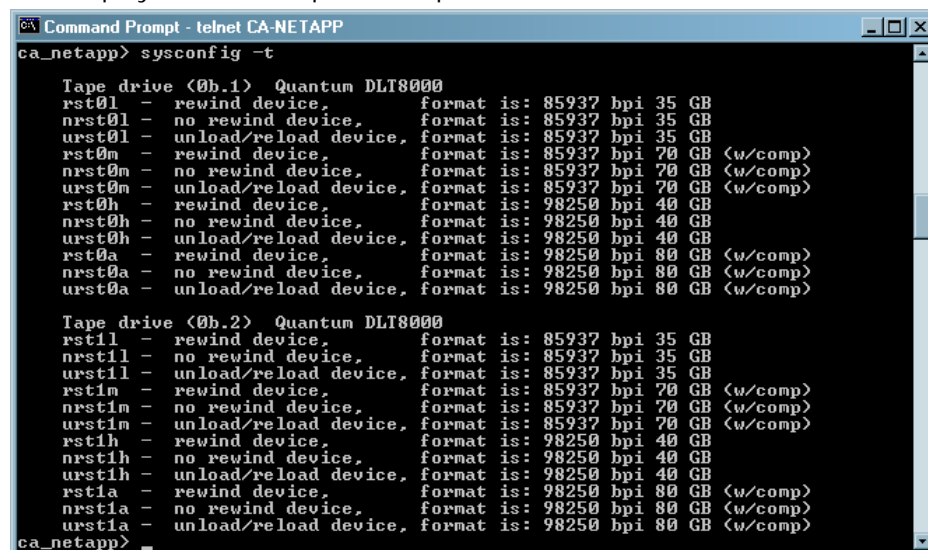

```

Command Prompt - telnet CA-NETAPP
ca_netapp> sysconfig -t

Tape drive <0b.1> Quantum DLT8000
rst01 - rewind device, format is: 85937 bpi 35 GB
nrst01 - no rewind device, format is: 85937 bpi 35 GB
urst01 - unload/reload device, format is: 85937 bpi 35 GB
rst0m - rewind device, format is: 85937 bpi 70 GB (w/comp)
nrst0m - no rewind device, format is: 85937 bpi 70 GB (w/comp)
urst0m - unload/reload device, format is: 85937 bpi 70 GB (w/comp)
rst0h - rewind device, format is: 98250 bpi 40 GB
nrst0h - no rewind device, format is: 98250 bpi 40 GB
urst0h - unload/reload device, format is: 98250 bpi 40 GB
rst0a - rewind device, format is: 98250 bpi 80 GB (w/comp)
nrst0a - no rewind device, format is: 98250 bpi 80 GB (w/comp)
urst0a - unload/reload device, format is: 98250 bpi 80 GB (w/comp)

Tape drive <0b.2> Quantum DLT8000
rst1l - rewind device, format is: 85937 bpi 35 GB
nrst1l - no rewind device, format is: 85937 bpi 35 GB
urst1l - unload/reload device, format is: 85937 bpi 35 GB
rst1m - rewind device, format is: 85937 bpi 70 GB (w/comp)
nrst1m - no rewind device, format is: 85937 bpi 70 GB (w/comp)
urst1m - unload/reload device, format is: 85937 bpi 70 GB (w/comp)
rst1h - rewind device, format is: 98250 bpi 40 GB
nrst1h - no rewind device, format is: 98250 bpi 40 GB
urst1h - unload/reload device, format is: 98250 bpi 40 GB
rst1a - rewind device, format is: 98250 bpi 80 GB (w/comp)
nrst1a - no rewind device, format is: 98250 bpi 80 GB (w/comp)
urst1a - unload/reload device, format is: 98250 bpi 80 GB (w/comp)
ca_netapp>

```

The tape logical device names listed by Network Appliance NAS servers use the following syntax:

`xxxx#@`

The following table explains the symbols and the corresponding values for the logical device names.

Symbo l	Value	Description
xxxx	nrst	A no-rewind sequential tape device. Opening and closing the device does not result in the device being automatically rewind.
	rst	A logical, sequential tape device that positions the actual device at the start of the tape during every open operation.
	urst	A logical, sequential tape device that loads and unloads the physical device in its open and close calls.
#	numeric	The device number. Device numbers start at 0.
@	l	Low-density mode for tape writes.
	m	Medium-density mode for tape writes.
	h	High-density mode for tape writes.
	a	High-density mode with hardware compression for tape writes.

Snapshot Configuration

You can use the NAS configuration file, `nas.cfg`, to browse the Network Appliance server's file system and snapshots. The `nas.cfg` file contains mappings of nodes to volumes or logical devices and their associated subdirectories that you may want to back up.

The configuration file allows you to do partial volume backups using the Backup Manager. If your Network Appliance server supports NDMP Version 4, you can automatically browse subdirectories and files in a volume and you do not need to configure the `nas.cfg` file for partial volume backups.

When you do back up data from a file system, the Network Appliance NAS server creates a snapshot of that data set so that the backup reflects a consistent view of the data at the time of the execution of the backup. The data is then indirectly backed up from this snapshot.

When you configure the `nas.cfg` file, you can auto-browse below the snapshot folder in the Backup Manager's source tree. To do this, enter the full path to the snapshot file under the Network Appliance server name in the configuration file.

The following is an example of configuring the `Daily0` snapshot file:

```
/vol/vol0/.snapshot/Daily.0
```

The following rules apply when you enter information in the NAS configuration file for a Network Appliance NAS server:

- Keep each entry on an individual line.
- Start with the host name of the NAS server.
- Put the volume and directory names on the next lines.
- Separate configurations by semicolons.
- Insert comments using the `#` symbol on individual lines or following any line entry.

When performing a recovery operation using the configuration file, you can make multiple selections per volume for a job. If the configuration file has multiple snapshot paths, you can select any multiple of snapshot paths, as you would for normal Network Appliance backups.

Example: Multiple-path Designations in a `nas.cfg` File

The following is an example of multiple-path designations in a `nas.cfg` file:

```
qa-server3  
/vol/vol0/.snapshot/Daily.0  
/vol/vol0/.snapshot/Monthly.1  
/vol/vol0/.snapshot/Weekly.3  
;
```

Snapshot backups should not be restored to the original location because they are read-only. You can, however, restore snapshot backups to an alternate location.

Option Limitations on Network Appliance Devices

There are limitations when using a Network Appliance NAS device with the NDMP NAS Option. These limitations are based on the version of NDMP in use on the NAS server. Limitations include the following:

- For backups, the use of filters is limited to exclude file and directory entries.
- Filters are not supported on restores.
- Use of tape drives is limited to those that are supported by Network Appliance.
- Use of tape library units is limited to those supported by CA.
- Although Network Appliance NAS devices support Direct Access Restore (DAR), the option supports file restoration only. If you choose to restore at least one folder, the restore reverts to scanning the session.

Note: For information about vendor-specific restrictions, see the appendix “Feature Support Summary.”

More information:

[Supported Backup Features](#) (see page 75)

[Supported Restore Features](#) (see page 78)

[Supported General Features](#) (see page 77)

Appendix B: Using EMC Celerra NAS Devices

This appendix contains information about how to use EMC Celerra NAS devices with the NDMP NAS Option.

This section contains the following topics:

[How the EMC Celerra Host Data Mover Works](#) (see page 57)

[Configure the EMC Celerra Data Mover](#) (see page 58)

[Option Limitations on EMC Celerra Devices](#) (see page 60)

How the EMC Celerra Host Data Mover Works

The Celerra File Server supports up to a maximum of four simultaneous backup operations on an NDMP Host Data Mover. You can connect multiple Host Data Movers to the same tape library unit. The tape library unit can have multiple SCSI host connections.

The tape library unit can also have fibre-channel connections. Do not connect the Celerra File Server Control Station to the tape library unit. For each tape library unit SCSI connection, you can attach a maximum of two drives. You cannot daisy chain any of the Host Data Mover storage system SCSI connections to the tape library unit.

If an NDMP Host Data Mover fails over to its standby, you must physically connect the Host Data Mover's tape library unit cable to the standby.

The ability to connect a Host Data Mover to a tape library unit is dependent on the number of SCSI ports on a Host Data Mover. Some older models of a Host Data Mover may have only two SCSI ports. These are required for storage system connectivity and redundancy. You should not use these storage system SCSI ports for tape library unit connections.

Configure the EMC Celerra Data Mover

Before the NDMP NAS Option can be used on an EMC Celerra NAS server, you must set parameters on the NAS server. You can specify most of these settings from any Telnet console.

You can use Telnet to access the system by entering the following command:

```
c::/> telnet <IP address of the Celerra>
```

Enter the administrator name and password to log in.

User Accounts

You must set a user name and password for each NDMP Host Data Mover at the Celerra File Server Control Station. The user name and password must match those you will enter for the NDMP NAS Option.

Enable NDMP on EMC Celerra Devices

To access the NDMP Host Data Movers on an EMC Celerra server, you must first enable the server.

To enable a device through a Telnet session

1. Verify that each NDMP Host Data Mover can recognize its tape library units by entering the following command:

```
$ server_devconfig <server_name> -probe -scsi -nondisks
```

Example: In the following example, the EMC Celerra server recognizes a two-drive library. The jbox value represents the tape library unit. In the next statements, tape represents the tape drives.

```
chain=1, scsi-1
```

```
symm_id= 0 symm_type= 0
```

```
tid/lun= 0/0 type= jbox info= ATL P1000 62200501.21
```

```
tid/lun= 4/0 type= tape info= QUANTUM DLT7000 245Fq_
```

```
tid/lun= 5/0 type= tape info= QUANTUM DLT7000 245Fq_
```

2. Configure the devices with the Celerra File Server by adding them to the host database using the following command:

```
$ server_devconfig <server_name> -create -scsi -nondisks
```

When a device is configured, the server responds with the following:

```
<server_name>: done
```

3. Enter the following command to verify that the configuration is set:

```
$ server_devconfig <server_name> -list -scsi -nondisks
```

The server responds with the following:

```
<server_name>:
```

```
Scsi Device Table
```

```
name addr type info
```

```
jbox1 c1t010 jbox ATL P1000 62200501.21
```

```
tape2 c1t410 tape QUANTUM DLT7000 245Fq_
```

```
tape3 c1t510 tape QUANTUM DLT7000 245Fq_
```

To view more commands specific to the Celerra, review the *Celerra File Server Command Reference Manual*. The manual has a comprehensive listing of all commands.

Logical Device Names Detection

If you do not want the NDMP NAS Option to automatically detect the drives, you can manually assign them when you configure the option. This is recommended if you are configuring your tape library unit and server on a SAN.

You must follow the previous instructions about how to determine the logical device names to be used in NDMP NAS Option. From the example in the previous section, they appear as c1t010, c1t410, and c1t510.

nas.cfg File Configuration - EMC Celerra Devices

CA ARCserve Backup can automatically determine the volumes mounted on the EMC Celerra NAS servers. CA ARCserve Backup employs NDMP Version 3 to interact with the volumes. To employ partial volume backups, you must configure the nas.cfg file.

For more information about configuring the nas.cfg file, see the section File System Configuration.

More information:

[File System Configuration](#) (see page 22)

Option Limitations on EMC Celerra Devices

There are certain limitations in using the EMC Celerra NAS servers with NDMP NAS Option. Some of these limitations are based on the version of NDMP in use on the NAS server. Limitations include the following:

- For backups, the use of filters is limited to exclude file and directory entries.
- Filters are not supported on restores.
- The use of tape drives is limited to those certified by EMC Celerra and the NDMP NAS Option.
- The use of tape library units is limited to those certified by CA.
- Although EMC Celerra NAS devices support Direct Access Restore (DAR), the option supports file restoration only. If you choose to restore at least one folder, the restore reverts to scanning the session.
- The progress bar or percentage complete statistics in CA ARCserve Backup does not display during a backup.

Note: For information about vendor-specific restrictions, see the appendix "Feature Support Summary."

Appendix C: Using EMC CLARiiON IP4700 NAS Devices

This appendix contains information about how to use EMC CLARiiON IP4700 NAS devices with the NDMP NAS Option.

This section contains the following topics:

[Configure the EMC CLARiiON IP4700 NAS Server](#) (see page 61)

[Option Limitations on EMC CLARiiON IP4700 Devices](#) (see page 64)

Configure the EMC CLARiiON IP4700 NAS Server

Before NDMP NAS Option can work with the EMC CLARiiON IP4700 NAS server, certain parameters must be set on the server. Most of these settings can be performed from the web-based Administrative Interface or directly from the console attached to the IP4700 NAS server.

To access the web-based Administrative Interface, enter the following URL in your Web browser address bar:

http://<IP address of the IP4700>

User Accounts

To access the EMC CLARiiON IP4700 NAS server through the NDMP NAS Option, the proper administrator password must be set on the device. For the device to be accessible to the option, the administrator password must not be null or empty. To configure the option, use the following information:

Username: Administrator

Password: <As set on the IP4700>

Enable NDMP on EMC CLARiiON IP4700 Devices

If the NDMP NAS Option is properly installed on the device, NDMP is enabled by default on EMC CLARiiON IP4700 NAS servers.

Logical Device Names

For NDMP NAS Option to be able to perform backup and restore operations on EMC CLARiiON IP4700 NAS servers, at least one server in the configuration must have tape drives or tape library units attached to it. The logical device names of the attached devices must be specified to the NDMP NAS Option.

These logical device names are automatically assigned to the devices by IP4700 depending on the SCSI settings and type of each device. The logical device names can also be determined from the Tape Drives menu of the web-based Administrative Interface.

Example: Logical Device Names

The following is an example of a typical Tape Drives information screen:

```
SP-A (IP4700SPA) HP C1557A U709 /dev/c0b0t6d0
SP-A (IP4700SPA) SCSI Device /dev/c0b0t6d1
SP-B (IP4700SPB) QUANTUM SuperDLT1 1717 /dev/c0b0t3d0
SP-B (IP4700SPB) QUANTUM SuperDLT1 1717 /dev/c0b0t3d0
SP-B (IP4700SPB) SCSI Device /dev/c0b0t5d0
```

Each line consists of three components:

- Storage processor
- Device description
- Logical device name

For example, consider the first line:

```
SP-A (IP4700SPA) HP C1557A U709 /dev/c0b0t6d0
```

In this line:

```
Storage Processor = SP-A (IP4700SPA)
Device Description = HP C1557A U709
Logical Device Name = /dev/c0b0t6d0
```

The last part of the line contains the logical device name (in this example, /dev/c0b0t6d0) used when configuring the NDMP NAS Option.

The second line in this example is:

```
SP-A (IP4700SPA) SCSI Device /dev/c0b0t6d1
```

This has the device description "SCSI Device." This device description indicates that this device is a tape library unit, not a regular tape drive. This logical device name can be used to configure the tape library unit on the NDMP NAS Option.

Network Configuration

When you configure the EMC CLARiiON IP4700 NAS server for the network, remember to:

- Assign a unique IP address to each of the storage processors in IP4700. The IP address must be set up from the console attached to the server.
- Unique host names must be assigned to each of the storage processors.
- The host names and IP addresses must be registered with the DNS server, so that they are accessible with the host name in any browser.

Note: If the host names are not properly configured in the DNS server and the storage processors are unable to resolve each other's names, backup and restore operations will not function properly.

If you have purchased the CIFS License from EMC, you should be able to access the volumes on the EMC CLARiiON IP4700 NAS server through Microsoft Windows. The domain name and WINS server must be configured on the IP4700.

Volume Configuration

Volumes are configured in accordance with the requirements of the NAS device. For NDMP NAS Option to function correctly, at least one volume must be configured on the server.

Depending on the operating system from which the volumes are accessed, CIFS shared directories and NFS exports must be configured with appropriate level of access rights.

Tape Drives and Tape Libraries

At least one tape drive or a tape library unit with at least one tape drive must be connected to the SCSI bus of an IP4700 in the NAS server configuration. Use the Tape Drive menu from the web-based Administrative Interface to ensure that the device is properly connected and is recognized by the IP4700. All of the tape drives and the tape library units must have an entry in the list.

Option Limitations on EMC CLARiiON IP4700 Devices

There are limitations when using an EMC CLARiiON IP4700 NAS server with the NDMP NAS Option. Some of these limitations are based on the version of NDMP in use on the NAS server. The limitations include the following:

- Only full volume backups can be performed. Restore operations, however, can be performed on selected files or folders.
- Backup and restore operations do not support any kind of filtering.
- Snapshot functionality is not supported.
- Direct Access Restore (DAR) is not supported.
- The option does not display a progress bar or percentage complete statistic in the Job Monitor.
- EMC CLARiiON IP4700 restore operations only support the option Create Entire Path from the Root on the Destination tab of the Restore Manager Global Options dialog.

Furthermore, the NDMP NAS Option cannot determine the volumes created on the IP4700 server. These volumes need to be determined manually and the file `nas.cfg` must be properly configured. You can determine the volume names that you need to enter on the `nas.cfg` file by viewing the web-based Administrative Interface.

The following is an example of volume information that you can view:

Name	Label	Size	Space Used	Status
A0		264910	15723	RDY
B0		264910	15569	RDY

The volume names ('A0' and 'B0' in this case) need to be put into the `nas.cfg` file.

Note: For information about vendor-specific restrictions, see the appendix "Feature Support Summary."

Appendix D: Using Procom NAS Devices

This appendix contains information about how to use Procom NAS devices with the NDMP NAS Option.

This section contains the following topics:

[Procom Server Configuration](#) (see page 65)

[nas.cfg File Configuration - Procom Devices](#) (see page 67)

[Option Limitations on Procom Devices](#) (see page 69)

Procom Server Configuration

Before the NDMP NAS Option can be used with Procom devices, you must set certain parameters on the NAS server. You can specify most of these settings from the web-based Administrative Interface. Additionally, some settings are performed directly on the LCD panel available on the Procom device.

To access the web-based Administrative Interface, enter the following URL in your web browser address bar:

http://<IP address of the Procom>

User Accounts

To access a Procom server through the NDMP NAS Option, an administrator password must be established on the Procom server. To access the Procom server, you would use the following information:

Username: administrator

Password: <As set on the Procom>

Logical Device Names

For the NDMP NAS Option to be able to perform backup and restore operations on a Procom server, the tape drives and tape library units attached to the server must be configured. This configuration differs depending on the firmware on the NAS server.

4.1 Firmware Configuration

For Procom servers with 4.1 firmware, you must specify the logical device names in the configuration file. You can determine these names from the System Log, accessible through the web-based interface.

Two lines in the System Log provide information about the tape drives and tape library units connected to the Procom server.

Example: System Log for Procom Servers with 4.1 Firmware

The following example shows sample lines from this log:

```
1/09 12:27 | robotape isp1?061 type=8 desc='HP C1557A '  
1/09 12:27 | tape isp1t060 'HP C1557A '
```

The line containing robotape indicates a tape library unit — not a regular tape device. Use the word after robotape to determine the logical device name for the tape library unit. In the example, this word is isp1?061. To obtain the logical device name for the tape library unit, replace the ? with r. Therefore, the logical device name is isp1r061.

The line containing tape indicates a tape drive connected to the Procom server. The word after tape (isp1t060 in this example) is the logical device name for the tape drive. There may be multiple entries in the log containing the word tape, if multiple tape drives were detected. In this situation, the log will contain one line for each detected tape drive.

4.2 Firmware Configuration

The NDMP NAS Option automatically detects connected tape devices attached to a Procom server with 4.2 firmware. Logical device names are automatically assigned to Procom servers, depending on the SCSI settings and type of each device.

Network Configuration

Network configuration involves assigning a unique IP address to the Procom server. If the DHCP server is available in the network, the Procom server can automatically obtain an IP address. You can determine the DHCP-assigned IP address by using the LCD panel on the Procom server.

You can manually assign an IP address to the server. You must use the LCD panel on the Procom server the first time you assign an IP address. You can configure additional parameters (for example, the DNS server and routing table) from the web-based interface.

You can access the Procom file system using either Microsoft Windows or UNIX. Each operating system has specific requirements to enable the access. These requirements are:

- For Microsoft Windows, the WINS server and domain name must be correctly set, and at least one share must be created.
- For UNIX, the appropriate exports must be created.

Volume Configuration

Volumes are configured according to the requirements of the NAS server used. For the NDMP NAS Option to function correctly, at least one volume must be configured on the server serving as the data source of the backup operation.

NAS separates storage resources from network and application servers to simplify storage management and to provide file-level access to data, using standard protocols such as Network File System (NFS) or Common Internet File System (CIFS). A file system is located on the NAS server, and data is transferred to the client over standard network protocols. Depending on the operating system from which the volumes are to be accessed, CIFS shared directories and NFS exports must be configured with appropriate access rights.

Tape Drives and Tape Library Units

At least one tape drive or a tape library unit with at least one tape drive must be connected to the SCSI bus of the Procom NAS server targeted as the destination for the backup data. You can read the System Log to verify that all the tape drives are properly connected and correctly detected by the Procom server.

nas.cfg File Configuration - Procom Devices

You can use the NAS configuration file, `nas.cfg`, to virtually browse the file system and checkpoints. You can browse in the Backup Manager's and Restore Manager's respective source and destination trees. The `nas.cfg` file contains mappings of nodes to volumes or logical devices and their associated subdirectories that you may want to back up. This configuration file also allows you to do partial volume backups from the Backup Manager.

The following rules apply when you enter information in the NAS configuration file:

- Keep each entry on an individual line.
- Start with the host name of the NAS server.
- Place the volume and directory names on the next lines.
- Separate complete NAS server configurations by semicolons.
- Insert comments using the # symbol on individual lines or following any node or volume name.

For NAS servers, you can select only one path per file system for a backup job. You are encouraged to run multiple jobs if you have multiple, disparate subtrees that need to be backed up under one file system.

Example: Multiple Path Designations in the nas.cfg File

The following is an example of multiple path designations in a nas.cfg file. You can select only one path under /c and one path under /d in the job.

```
/c/dir1  
/c/dir2  
/c/dir3  
/d/dir1  
/d/dir2  
/d/dir3  
;
```

Example: Multiple Checkpoint Destinations in a nas.cfg File

The following is an example of multiple checkpoint designations in a nas.cfg file:

```
qaprocom15  
/c.chkpt/daily  
/c.chkpt/hourly  
/c.chkpt/monthly  
/c/etc  
/c/etc/xyz  
;
```

Checkpoint backups should not be restored to the original location because they are read-only. You can, however, restore checkpoint backups to an alternate location.

More information:

[File System Configuration](#) (see page 22)

Option Limitations on Procom Devices

There are limitations when using a Procom server with the NDMP NAS Option. Some of these limitations include the following:

- Restore jobs do not support any kind of filtering.
- Direct access restores are not supported.
- Backup jobs support Exclude filters on directory and file names only.
- The NDMP NAS Option does not display a progress bar or percentage complete statistic in the Job Monitor.
- Procom restore operations only support the option Create Entire Path from the Root on the Destination tab of the Restore Manager Global Options dialog.

Some of these limitations arise because of the version of NDMP in use on the Procom server. If the Procom server firmware version is earlier than 4.02.10, the NDMP NAS Option cannot automatically determine the volumes created on the Procom server. You must determine the volume names and use the names to configure the nas.cfg file. These volume names can be determined from the web-based Administrative Interface.

To determine the names of the volumes, use the web-based Administrative Interface to display the File Volume Usage window. Volume names that are file volumes available on the Procom server appear in the name column. Insert these names into the nas.cfg file.

Note: For information about vendor-specific restrictions, see the appendix "Feature Support Summary."

Appendix E: Troubleshooting

This appendix contains information about how you can troubleshoot the CA ARCserve Backup NDMP NAS Option.

This section contains the following topics:

[Devices Do Not Display in the Device Manager](#) (see page 71)

[NAS Server Does Not Reinitialize](#) (see page 72)

[Debugging is Not Enabled on the NAS Server](#) (see page 72)

[Cannot Access the Procom System Log and Environmental Log](#) (see page 73)

[Unable to Restore QTree Information Using the NDMP NAS Option](#) (see page 74)

Devices Do Not Display in the Device Manager

Valid on Windows platforms.

Symptom:

NAS servers or tape libraries attached to a NAS server do not display in the Device Manager. How can I correct this problem?

Solution:

There are two probable causes:

- The server name, user name, or user password is incorrect or not configured.
- The device may be in use.

If the devices do not appear in the Device Manager, you should:

- Verify that the name of the server, with the corresponding user name and password were configured correctly using the CA ARCserve Backup Device Configuration dialog. For more information about configuring a NAS device, see [Configure NAS Devices](#) (see page 26).
- Verify that the tape drive is not already opened and in use by another NDMP session (only one connection is allowed at one time). Check to see if there are any leading or trailing spaces in the logical device name strings.
- If you configured the NAS server using a hostname, rather than an IP address, you should use the Backup Manager to configure the option to use the NAS server's hostname.

NAS Server Does Not Reinitialize

Valid on Windows platforms.

Symptom:

The NAS server does not reinitialize.

Solution:

You must manually reinitialize the NAS server.

To reinitialize the NAS server

1. Stop all of the sessions on the NETAPP NAS server by connecting to the server using Telnet and entering the following command:

```
ndmpd -killall
```
2. Restart the NDMP NAS Option universal agent service.
3. If necessary, delete the device references under the following registry key:

```
Computer Associates\CA ARCserve\Base\Tape Engine
```
4. If you are reconfiguring tape library units, run Device Configuration.
5. Restart the Tape Engine using the CA ARCserve Backup Server Admin.

Debugging is Not Enabled on the NAS Server

Valid on Windows platforms.

Symptom:

Debugging is not enabled on the NAS server.

Solution:

You must manually enable debugging on the NAS server.

To enable debugging on the NDMP server

1. Log in to the remote NAS server using Telnet and enter the following command:

```
ndmpd debug 50
```

Note: The number 50 indicates the level of debugging information.

2. The debugging information is written to a file that can be found in the root directory of the volume. The format of the file name is:

```
ndmpd.####
```

where ##### represents the date and time of the log.

Cannot Access the Procom System Log and Environmental Log

Valid on Windows platforms.

Symptom:

How can I access the Procom System Log and Environmental Log?

Solution:

You can access the Procom System Log and Environment Log by opening the web-based Administrative Interface and selecting the Monitoring and Notification option.

To view the Procom System Log and Environmental Log

1. Open a browser window and enter the following:

```
http://<machine>>
```

where <machine> is the URL of the Procom server.
2. Log in to the server.
3. Select Monitoring and Notification, View System Events, and Display Log.
The System Log and Environmental Log open.

Unable to Restore QTree Information Using the NDMP NAS Option

Valid on Windows platforms.

Symptom:

CA ARCserve Backup cannot restore Qtree information when you select only the folder that represents the Qtree information from the backup session, and the entire volume is selected.

Solution:

There are two remedies that you can use to solve this problem.

1. Restore the entire volume from the backup sessions with the entire volume selected.
2. Set the following registry key value to restore the qtree information properly.

Key:

HKEY_LOCAL_MACHINE\SOFTWARE\ComputerAssociates\CA ARCserve Backup\NASAgent\Parameters

Value Name:

bForceSelectiveFileRestore

Type:

DWORD

Value:

1 (Default is 0)

Note: After you set the above registry key, CA ARCserve Backup records the following message in the Activity Log when the restore job runs:

At least one of the source files or directories selected does not support direct positioning, using Selective file restore instead.

Appendix F: Feature Support Summary

This appendix presents the supported and unsupported features of the NDMP NAS Option for Network Appliance, EMC, and Procom NAS servers. The backup and restore tables are organized by a dialog tab and the features contained on each tab. "All" indicates that everything on that dialog tab is either supported or unsupported.

This section contains the following topics:

[Supported Backup Features](#) (see page 75)

[Supported General Features](#) (see page 77)

[Supported Restore Features](#) (see page 78)

[Support for NDMP V4](#) (see page 79)

[Certified NAS Devices](#) (see page 79)

Supported Backup Features

The following table lists the backup features for the NAS servers that the NDMP NAS Option supports:

Key:

✓— Supported options

✗— Unsupported options

W— Supported on Windows platforms only.

Tab	Feature	Network Appliance	EMC Celerra	EMC IP4700	Procom
Backup Media					
	Options for First Backup Media (All)	✓	W	W	W
	Options for Additional Backup Media (All)	✓	W	W	W
	Compression/Encryption Password (All)	✗	✗	✗	✗
Verification	(All)	✗	✗	✗	✗

Tab	Feature	Network Appliance	EMC Celerra	EMC IP4700	Procom
Retry	(All)	x	x	x	x
Operation	Delete Files After Backup/Disable File Estimate/Calculate and Store CRC on the Backup Media/Back up of the CA ARCserve Backup database	x	x	x	x
	Eject Backup Media upon Completion	✓	W	W	W
	Database	✓	W	W	W
Pre/Post	(All)	✓	W	W	W
Job Log	(All)	✓	W	W	W
Virus	(All)	x	x	x	x
Replication	(All)	x	x	x	x
Alert	(All)	✓	W	W	W
Volume Shadow Copy Service					
	(All)	x	x	x	x
Media Exporting					
	Option	x	x	x	x
	Media Option	✓	W	W	W
Advanced	(All)	x	x	x	x
Filter	Exclude File and Directory Pattern	✓	x	x	W
	Include File and Directory Pattern	x	x	x	x
	All Other Filters	x	x	x	x

Supported General Features

The following table lists the major options supported by the NDMP NAS Option.

Key:

✓— Supported options

✗— Unsupported options

W— Supported on Windows platforms only

Description	Network Appliance	EMC Celerra	EMC IP4700	Procom
Rotation Backup	✓	W	✗	W
GFS Rotation Backup	✓	W	W	W
Custom Incremental Backup	✗	W	✗	W
Custom Differential Backup	✗	W	W	W
Volume-Level Backup	✓	W	W	W
Directory and File-Level Backup	✓	W	✗	W
Volume-Level Restore	✓	W	W	W
Directory and File-Level Restore	✓	W	W	W
Snapshot/Checkpoint	✓	✗	✗	W
Direct-Access Restore	✓	W	✗	✗

Supported Restore Features

The following table lists the restore features for the NAS servers that the NDMP NAS Option supports.

Key:

✓— Supported options

✗— Unsupported options

W— Supported on Windows platforms only

Tab	Feature	Network Appliance	EMC Celerra	EMC IP4700	Procom
Backup Media	(All)	✓	W	W	W
Destination	Directory Structure	✓	W	✗	✗
	File Conflict Resolutions	✗	✗	✗	✗
Operation	Restore and Preserve Directory Attributes / Restore Registry and Event Logs	✗	✗	✗	✗
	Database	✓	W	W	W
Pre/Post	(All)	✓	W	W	W
Job Log	(All)	✓	W	W	W
Virus	(All)	✗	✗	✗	✗
Alert	(All)	✓	W	W	W
Filter	(All)	✗	✗	✗	✗

Support for NDMP V4

The CA ARCserve Backup NDMP NAS Option supports NDMP version 4 in addition to NDMP version 3.

Note: The NDMP NAS Option no longer supports NDMP version 2. If you are using NDMP version 2, contact [CA Technical Support](#) before you upgrade to the latest version of CA ARCserve Backup for Windows.

Certified NAS Devices

The following versions of NAS devices are certified for this release:

- For Network Appliance devices:
 - ONTAP Version 7.1
 - OnStor (V4)
 - Procom (V3)
 - EMC IP4700 (V3)

We recommend that you configure the filer to allow NDMP V4 communication by executing the following command on the filer console:

```
ndmpd version 4
```

In addition, ensure that all the filers are configured to 4.

- For EMC (Celerra) devices:
 - DART version 5.5
 - NAS Server model: Celerra

DART 5.5 now supports exclude filters and DAR options at Job Level only. For more information on configuring EMC Celerra devices to support files and folder filters, see the EMC Celerra documentation.

To use Dynamic Device Sharing (DDS), set the value of `ndmp.scsiReserve` to 0. The default value of `ndmp.v4oldTapeCompatible` should be set to 1.

We recommend that you configure data movers to support NDMP V4 communication by setting the `maxProtocolVersion` parameter to 4. In addition, ensure that all data movers are configured to 4.

Index

B

backing up data

- add a NAS server • 34
- archive data • 40
- back up a NAS server • 36
- options • 33
- scheduling a backup • 36

C

checkpoints • 24, 34, 46, 67

configuring user accounts

- EMC Celerra devices • 58
- EMC CLARiiON IP4700 devices • 61
- Network Appliance devices • 52
- Procom devices • 65

contacting technical support • v

customer support, contacting • v

D

device configuration • 26

dynamic device sharing

- about • 18
- configuring • 30
- using Device Configuration • 31

E

EMC Celerra devices

- configuring user accounts • 58
- enabling NDMP • 58
- limitations • 60
- logical device names • 59
- NAS configuration • 58
- nas.cfg configuration • 60

EMC CLARiiON IP4700 devices

- configuring user accounts • 61
- enabling NDMP • 61
- limitations • 64
- logical device names • 53, 62
- NAS configuration • 61
- network configuration • 63
- tape drives and tape libraries • 63
- volume configuration • 63

F

features

- local and three-way backup and restores • 11
- NAS changer support • 11
- push technology • 11
- real-time remote browsing • 11

I

installation

- prerequisites • 21
- procedure • 25

L

local NDMP backup • 14

local NDMP restore • 16

logical device names

- EMC Celerra devices • 59
- EMC CLARiiON IP4700 devices • 53, 62
- Network Appliance devices • 53
- Procom devices • 65

logs • 20

M

media assure & scan utility • 48

merge utility • 48

N

NAS configuration

- add a NAS server • 34
- EMC Celerra devices • 58
- EMC CLARiiON IP4700 devices • 61
- Network Appliance devices • 51
- Procom devices • 65

nas.cfg configuration file • 22, 24, 34, 54, 60, 64, 67, 69

Network Appliance devices

- administrative interface, accessing • 51
- configuring user accounts • 52
- limitations • 56
- snapshots • 54

P

Procom devices

- configuring user accounts • 65
- limitations • 69
- logical device names • 65
- NAS configuration • 65
- network configuration • 66
- tape drives and tape libraries • 67
- troubleshooting • 73
- volume configuration • 67

R

- restoring data
 - options • 40
 - restore by session • 42
 - restore by tree • 41
 - restore destination tab • 46

S

- snapshot • 24, 34, 54
- snapshot management extensions • 24
- support, contacting • v

T

- tape drives and tape libraries
 - EMC CLARiiON IP4700 devices • 63
 - Network Appliance devices • 53
 - Procom devices • 67
- Tape Engine Debug Log • 20, 30
- technical support, contacting • v
- three-way NDMP backup • 15
- three-way NDMP restore • 16
- troubleshooting, general • 71, 72

V

- volume configuration
 - EMC CLARiiON IP4700 devices • 63
 - Procom devices • 67