

CA Spectrum[®] Infrastructure Manager

Non-Persistent Connections Manager User Guide

r9.2



This documentation and any related computer software help programs (hereinafter referred to as the "Documentation") are for your informational purposes only and are subject to change or withdrawal by CA at any time.

This Documentation may not be copied, transferred, reproduced, disclosed, modified or duplicated, in whole or in part, without the prior written consent of CA. This Documentation is confidential and proprietary information of CA and may not be used or disclosed by you except as may be permitted in a separate confidentiality agreement between you and CA.

Notwithstanding the foregoing, if you are a licensed user of the software product(s) addressed in the Documentation, you may print a reasonable number of copies of the Documentation for internal use by you and your employees in connection with that software, provided that all CA copyright notices and legends are affixed to each reproduced copy.

The right to print copies of the Documentation is limited to the period during which the applicable license for such software remains in full force and effect. Should the license terminate for any reason, it is your responsibility to certify in writing to CA that all copies and partial copies of the Documentation have been returned to CA or destroyed.

TO THE EXTENT PERMITTED BY APPLICABLE LAW, CA PROVIDES THIS DOCUMENTATION "AS IS" WITHOUT WARRANTY OF ANY KIND, INCLUDING WITHOUT LIMITATION, ANY IMPLIED WARRANTIES OF MERCHANTABILITY, FITNESS FOR A PARTICULAR PURPOSE, OR NONINFRINGEMENT. IN NO EVENT WILL CA BE LIABLE TO THE END USER OR ANY THIRD PARTY FOR ANY LOSS OR DAMAGE, DIRECT OR INDIRECT, FROM THE USE OF THIS DOCUMENTATION, INCLUDING WITHOUT LIMITATION, LOST PROFITS, LOST INVESTMENT, BUSINESS INTERRUPTION, GOODWILL, OR LOST DATA, EVEN IF CA IS EXPRESSLY ADVISED IN ADVANCE OF THE POSSIBILITY OF SUCH LOSS OR DAMAGE.

The use of any software product referenced in the Documentation is governed by the applicable license agreement and is not modified in any way by the terms of this notice.

The manufacturer of this Documentation is CA.

Provided with "Restricted Rights." Use, duplication or disclosure by the United States Government is subject to the restrictions set forth in FAR Sections 12.212, 52.227-14, and 52.227-19(c)(1) - (2) and DFARS Section 252.227-7014(b)(3), as applicable, or their successors.

Copyright © 2010 CA. All rights reserved. All trademarks, trade names, service marks, and logos referenced herein belong to their respective companies.

CA Product References

This document references the CA Spectrum® Infrastructure Manager (CA Spectrum).

Contact CA

Contact Technical Support

For your convenience, CA provides one site where you can access the information you need for your Home Office, Small Business, and Enterprise CA products. At <http://ca.com/support>, you can access the following:

- Online and telephone contact information for technical assistance and customer services
- Information about user communities and forums
- Product and documentation downloads
- CA Support policies and guidelines
- Other helpful resources appropriate for your product

Provide Feedback

If you have comments or questions about CA product documentation, you can send a message to techpubs@ca.com.

If you would like to provide feedback about CA product documentation, complete our short [customer survey](#), which is also available on the CA Support website, found at <http://ca.com/docs>.

Contents

Chapter 1: Getting Started with Non-Persistent Connections	7
Introduction	7
Non-Persistent Connection Types	8
Create Dialup_Link Models	8
Chapter 2: Configuring Non-Persistent Connections	11
How to Configure Non-Persistent Connections	11
Basic Non-Persistent Connections	12
Dialer Map-Based Dial-on-Demand Routing (DDR) Configurations	13
Modeling a Map-Based DDR Configuration	14
Map-Based DDR Connections with Multilink Secondary Interfaces	15
Modeling DDR Map-Based Connections with Multilink Secondary Interfaces	15
Secondary Groups	17
Dialer Profile DDR Configurations	17
Representing a Dialer Interface with CA Spectrum	18
Modeling a Dialer Profile Connection	18
Monitoring a Dialer Profile Connection	20
Multiple Dial Backup Links	20
How to Model Multiple Remote Routers to a Common Host Router	21
How to Model a Single Remote Router to Multiple Host Routers or Host Router Interfaces	22
Chapter 3: Monitoring Non-Persistent Connections	23
Viewing Dialup_Link Model Information	23
Searching for Non-Persistent Connections	26
Determining the Status of Multiple Primary or Secondary Links	27
Dialup_Link Condition Colors	27
Alarms	29
Index	33

Chapter 1: Getting Started with Non-Persistent Connections

This section contains the following topics:

[Introduction](#) (see page 7)

[Non-Persistent Connection Types](#) (see page 8)

[Create Dialup Link Models](#) (see page 8)

Introduction

This chapter provides an overview of the non-persistent connections functionality available in CA Spectrum OneClick and describes the types of links you can manage.

You can manage transient communications links using OneClick's non-persistent connections functionality. Non-persistent connections generally remain in an inactive state and are activated only under certain conditions. They can be activated manually as needed to serve as normal dialup type communications links, or they can be configured to activate automatically in either of the following two scenarios:

- To serve as a backup when failure of a primary connection occurs
- To provide load balancing or extra bandwidth for another overloaded communications link

Non-persistent connections let you see:

- When a link is activated
- Whether a link has failed to activate
- How long a particular link has been active

Events and alarm conditions are generated and logged to maintain accurate link usage statistics. Also, you can view the links as icons so that you can differentiate between normal connections and non-persistent connections and determine a connection's current status at a glance. Within CA Spectrum these non-persistent connections are represented by the Dialup_Link model type.

Non-Persistent Connection Types

When you create a Dialup_Link model, you choose the type of connection that best suits your needs. The Dialup_Link model type provides functionality for the following three distinct types of non-persistent connections:

Dial Backup Link (DBL)

A Dial Backup Link (DBL) provides a redundant link if a primary link fails. This type of link provides monitoring support for a one-to-one relationship between primary and secondary links and it provides support for multiple primary and secondary link configurations. Each DBL model can provide monitoring capabilities for multiple primary links using a common secondary interface. This is useful when many remote sites use one phone number at a central site (common interface) to support a non-persistent connection.

Bandwidth on Demand Link (BODL)

A Bandwidth on Demand Link (BODL) provides extra bandwidth for connections experiencing congestion problems. Links of this type may or may not be active in conjunction with the primary link. BODLs provide the same redundant capabilities as Dial Backup Links.

Primary on Demand Link (PODL)

A Primary on Demand Link (PODL) is not a redundant connection of any type. These links are activated manually when needed and function as a primary connection. There is no primary-secondary relationship involved.

Create Dialup_Link Models

This section explains how to create a Dialup_Link model to represent a non-persistent connection. You should create one Dialup_Link model for each phone number that remote routers could dial to create the non-persistent connection. Dialup_Link models must be created manually. If the remote router can dial one number that can be picked up by one of several host routers or host router interfaces, one Dial_Up link model is used to represent this connection.

To create a Dialup_Link model

1. In the Explorer tab of the OneClick Navigation panel, locate the Universe topology view where the devices involved in the non-persistent connection reside.

The selected Universe topology view appears in the Topology tab of the Contents panel.

2. In the Topology tab toolbar, click  (Creates a new model by type).

The Select Model Type dialog opens.

3. Click the All Model Types tab.
A list of model types opens.
4. Type **Dialup_Link** in the Filter text box to filter the list to show the Dialup_Link model type only.
5. Select the Dialup_Link model type and click OK.
The Create Model Of Type Dialup_Link dialog opens.
6. In the Create Model Of Type Dialup_Link dialog, complete the following fields, which describe the device model type you are modeling.

Name

Specifies a unique name for the Dialup_Link device you are modeling. This appears in the Topology view with the icon.

Limits: 1 to 16 ASCII characters

Security String

Specifies a CA Spectrum Security String for this Dialup_Link model.

Note: See the *Administrator Guide* for more information about setting up security in CA Spectrum.

Dialup Link Type

Specifies the functional type of the Dialup_Link. Possible types are Dial Backup Link, Primary on Demand Link, and Bandwidth on Demand Link.

Dialup Protocol Type

Specifies the protocol type to use on the Dialup_Link. Possible protocol types include Analog, Switch-56, ISDN, Frame_Relay, and Other. This appears in the Topology view with the icon.

Activation Grace Period (Min)

Specifies the time allowed, in minutes, for the secondary link to become active after a primary link failure. If this grace period expires before the secondary link is active, then a red alarm is generated.

Default: 3 minutes

Deactivation Grace Period (Min)

Specifies the time allowed, in minutes, for an active secondary link to deactivate after the failed primary link reactivates. If the secondary link is still active after this grace period expires, then a yellow alarm is generated.

Default: 3 minutes

Active Time Until Yellow (Hours)

Specifies the number of hours a backup link can be active before a yellow alarm is generated.

Active Time Until Orange (Hours)

Specifies the number of hours a backup link can be active before an orange alarm is generated.

Active Time Until Red (Hours)

Specifies the number of hours a backup link can be active before a red alarm is generated.

7. Click OK to create a modeled device icon for the specified device and close the dialog.

The Dialup_Link model appears in the selected Topology view.

Note: When first created, the model will be in a normal inactive state and will have a brown condition.

8. (Optional) Click the Edit mode button in the Topology tab toolbar to move the device icon to a more appropriate location in the Topology view.

Note: For more information about editing, annotating, or enhancing a modeled element, see *Modeling and Managing Your IT Infrastructure Administrator Guide*.

Chapter 2: Configuring Non-Persistent Connections

This section contains the following topics:

[How to Configure Non-Persistent Connections](#) (see page 11)

[Basic Non-Persistent Connections](#) (see page 12)

[Dialer Map-Based Dial-on-Demand Routing \(DDR\) Configurations](#) (see page 13)

[Map-Based DDR Connections with Multilink Secondary Interfaces](#) (see page 15)

[Dialer Profile DDR Configurations](#) (see page 17)

[Multiple Dial Backup Links](#) (see page 20)

How to Configure Non-Persistent Connections

Configuring non-persistent connections involves identifying primary and secondary interfaces on the appropriate remote and host router or routers. Remote routers initiate dialup links. Host routers answer dialup calls from remote routers to establish the link. Management information is obtained by monitoring the remote router or routers.

Dial Backup Links (DBLs) and Bandwidth on Demand Links (BODLs) involve the redundant relationship between a primary link and a secondary link or links. The Dialup_Link model representing a DBL or a BODL monitors a primary link for a possible failure; it also monitors a related secondary link to verify its activation in a backup or supporting role if the primary link fails.

In general, the process to follow for configuring these types of links is as follows:

1. Configure the secondary interface or interfaces on the remote router or routers. This involves resolving the Dialup_Link model to the secondary interface.

This is the interface that will serve as the dialing end of the dialup connection.

2. Configure the primary interface or interfaces on the remote router or routers.

If all the primary interfaces go down, the dialup connection is used.

3. If known, configure the secondary interface or interfaces on the host router that will serve as the receiving end of the dialup connection.

Note: Primary on Demand Links (PODLs) are non-persistent connections that are used as transient primary links. You configure these links using this same process, however, since this type of link model does not need to monitor a primary interface, you can ignore the second step.

Basic Non-Persistent Connections

The Non-Persistent Connection solution requires that the primary and secondary interfaces reside on the same remote router. This leads us to the following most basic supported scenario in which only one end of the connection is known:

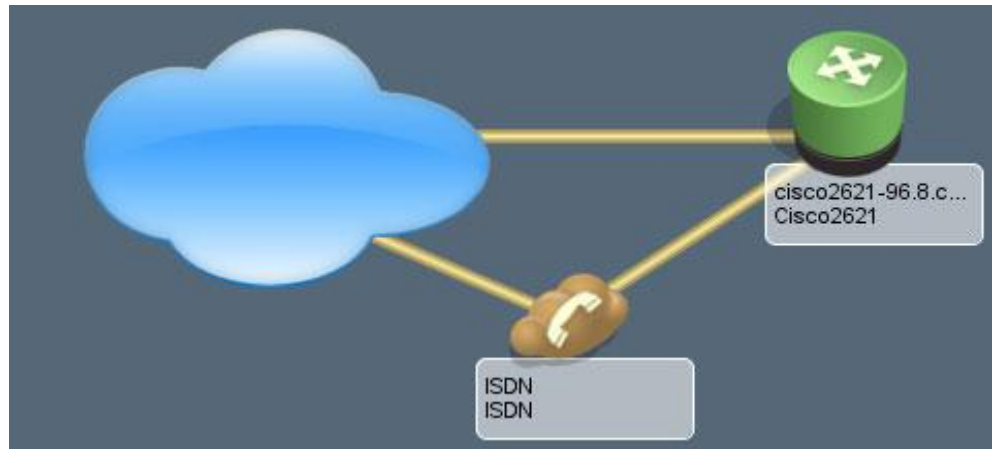

As illustrated by the previous image, in this case, only the remote (dialing) side of the redundant setup is known. As such, you would set up this scenario as described in the following procedure.

To model a basic non-persistent connection when only one end is known

1. Right-click the primary interface on the router and select 'Non-Persistent Connection Setup, Identify NPC Backup For This Interface.'
2. Right-click the backup interface which should be activated if the primary interface is unavailable and select 'Non-Persistent Connection Setup, NPC Backup For <primary interface>.'

The Create Model of Type Dialup_Link dialog appears.

3. Create a Dialup_Link model.

Another basic non-persistent connection is one in which both the initiating and the receiving routers involved in the dialup connection are known, as illustrated by the following image:

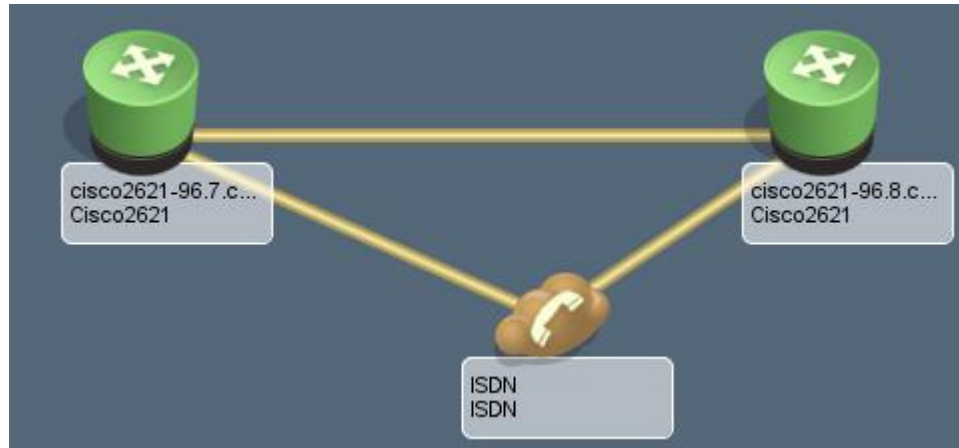

To model a basic non-persistent connection when both ends are known

1. Complete all the steps in the previous procedure, "To model a basic non-persistent connection when only one end is known."
2. Right-click the interface model on the remote router that is initiating the dial backup link and select 'Non-Persistent Connection Setup, Start Non-Persistent Connection.'
3. Right-click the interface model on the host router interface that is on the receiving end of the dial backup link and select 'Non-Persistent Connection Setup, Connect With <interface from step 2>.'

This creates a link between the Dialup_Link model and the host router interface on the receiving end of the non-persistent connection.

More information:

[Create Dialup_Link Models](#) (see page 8)

Dialer Map-Based Dial-on-Demand Routing (DDR) Configurations

This section discusses modeling a non-persistent connection that uses a Dial-on-Demand Routing (DDR) configuration that is map-based.

A DDR configuration that is map-based (often referred to as a legacy DDR configuration) associates a call specification for a single destination and a particular physical interface configuration. The physical interface contains all the configuration information that relates to receiving or making calls, and the bearer channels inherit the physical interface's configuration.

Modeling a Map-Based DDR Configuration

To model a DDR configuration that is map-based, create the appropriate number of Dialup_Link models and then configure the connection for each Dialup_Link model.

To model a map-based DDR configuration

1. Create one Dialup_Link model for each phone number that the remote router or routers could dial to create the non-persistent connections.

Note: If the remote router can dial one number that can be picked up by one of several host routers or host router interfaces, you can use just one Dial_Up link model to represent this connection.

2. Associate each Dialup_Link model you created with one of the secondary (dialing) interfaces on the remote router:
 - a. Right-click the Dialup_Link model and select 'Non-Persistent Connection Setup, Start Non-Persistent Connection.'
 - b. Right-click the associated secondary (dialing) interface on the remote router and select 'Non-Persistent Connection Setup, Connect With <Dialup_Link model>.'
3. Specify a primary interface for each Dialup_Link model. In the event that the primary interface goes down, the secondary link represented by the Dialup_Link model will activate:
 - a. Select the Dialup_Link model and then click the Information tab in the Component Detail panel.
 - b. Expand the Primary and Secondary Interface Information subview.
 - c. In the Primary Interfaces table, click  (Add).
 - d. Select one or more primary interfaces in the resulting dialog and then click Add.
 - e. Repeat for each Dialup_Link model that is part of this non-persistent connection configuration.

4. Associate each Dialup_Link model to the secondary (receiving) interfaces on the host router or routers.
 - a. Right-click the Dialup_Link model and select 'Non-Persistent Connection Setup, Start Non-Persistent Connection.'
 - b. Right-click the appropriate secondary (receiving) interface on the host router and select 'Non_Persistent Connection Setup, Connect With <Dialup_Link model>.'
 - c. Repeat for each Dialup_Link model that is part of this non-persistent connection configuration.

More information:

[Create Dialup_Link Models](#) (see page 8)

Map-Based DDR Connections with Multilink Secondary Interfaces

This section discusses modeling a non-persistent connection that uses one Dialup_Link model to specify a secondary link consisting of multiple interfaces that make up one logical link. This secondary link can be initiated by one or more ports on the remote router.

Modeling DDR Map-Based Connections with Multilink Secondary Interfaces

You can use one Dialup_Link model to support multiple secondary interfaces on a single remote router. For example, if your dialup connection uses a Multilink PPP over ISDN BRI configuration, you could associate a single Dialup_Link model with each PPP interface associated with the ISDN bearer channel connections.

The following diagram shows a remote router that has two connections to a host router. Since these two connections make up one logical link, you can use one Dialup_Link model to represent the link. Depending on the type of connectivity you are using, you can resolve the Dialup_Link model at the interface or the subinterface level.

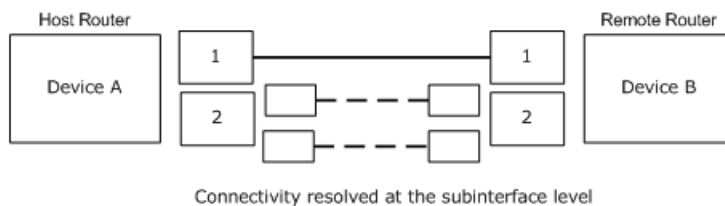
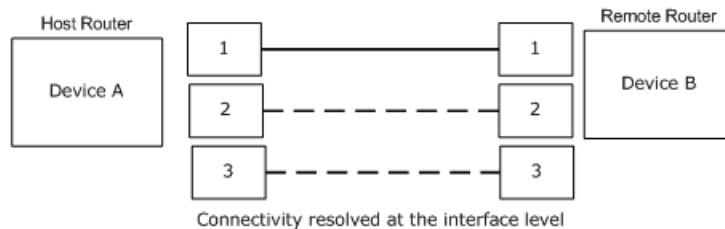

Primary Link _____
 Secondary Link - - - - -

To model DDR map-based connections with multilink secondary interfaces on a remote router

1. Right-click the primary interface on the remote router and select 'Non-Persistent Connection Setup, Identify NPC Backup For This Interface.'
2. Right-click one of the the backup interfaces that should activate when the primary interface is unavailable and select 'Non-Persistent Connection Setup, NPC Backup For <primary interface>.'

The Create Model of Type Dialup_Link dialog opens.

3. Create a Dialup_Link model.
4. Repeat Step 2 for the remaining secondary interfaces.
5. Right-click the Dialup_Link model and select 'Non-Persistent Connection Setup, Start Non-Persistent Connection.'
6. Right-click one of the receiving interfaces on the host router and select 'Non-Persistent Connection Setup, Connect with <Dialup-Link model>.'
7. Repeat Step 6 for each secondary (receiving) interface on the host router.

More information:

[Create Dialup Link Models](#) (see page 8)

Secondary Groups

When a Dialup_Link model is associated with more than one interface on the same device, these interfaces will form a secondary group. CA Spectrum determines the status of the connection by looking at the state of the group. The DevSecGrpActiveCriteria attribute lets you change how CA Spectrum determines the state of the secondary group. This attribute has a default value of AnySecondaryIFActive (0), meaning that the group will be active if any member of the group is up and dormant only if all members of the group are down. The other possible value for this attribute is AllSecondaryIfsActive (1). If this is the value, the secondary group is considered active only if all members of the group are up, and is considered inactive if one member goes down. You can change the value of this attribute in the Dialup_Link model's Attributes tab.

Note: For more information about modifying attributes, see *Modeling and Managing Your IT Infrastructure Administrator Guide*.

Dialer Profile DDR Configurations

This section discusses modeling a non-persistent connection that uses a DDR configuration with dialer profiles.

In DDR Configurations that are dialer map-based, each physical interface can have only one set of configuration characteristics. When using a DDR configuration with dialer profiles, physical interfaces take on different characteristics based on incoming or outgoing call requirements. This is possible because dialer profiles separate logical configurations from the physical interfaces that receive or make calls. This lets interfaces such as ISDN, asynchronous modems, or synchronous serial connections be shared by multiple dialer profile configurations. The logical and physical interfaces are associated dynamically on a per call basis.

A dialer profile is made up of three main components:

Dialer Interface

Logical interfaces that represent a call to a particular destination. The dialer interface configuration contains all configuration settings specific to the destination. A router can have one or more dialer interfaces. Each interface references a group of physical interfaces called a dialer pool.

Dialer Pool

A group of physical interfaces that are associated with a dialer profile. A physical interface can belong to multiple dialer pools.

Physical Interface

Each physical interface is able to determine the dialer pool to which it belongs. Interfaces in a dialer pool are configured for encapsulation parameters and each dialer profile supports PPP and HDLC encapsulation.

Representing a Dialer Interface with CA Spectrum

CA Spectrum uses a logical interface model to represent a dialer interface; the logical interface model represents a call to or from a particular destination. This model is automatically created when CA Spectrum discovers a DDR dialer profile configuration on a device.

For example, if CA Spectrum discovers a dialer profile configuration on a Cisco router, the following logical interface model is used to represent a dialer interface. If there are multiple dialer interfaces configured on the router, multiple logical interfaces are created.

Modeling a Dialer Profile Connection

To model a connection that makes use of dialer profiles, create the appropriate number of Dialup_Link models and then configure the connection for each Dialup_Link model. Dialer profiles can be used on the remote router, on the host router, or both. Create one Dialup_Link model for each phone number that the remote router could dial to create the non-persistent connection.

If the remote router can dial one number that can be picked up by one of several host routers or host router interfaces, one Dial_Up link model is used to represent this connection.

To model a dialer profile DDR connection

1. Create a Dialup_Link model for each phone number the remote routers could dial.
2. Associate each Dialup_Link model with one of the secondary (dialing) interfaces on the remote router:
 - a. Right-click the Dialup_Link model and select 'Non-Persistent Connection Setup, Start Non-Persistent Connection.'
 - b. Right-click the associated secondary (dialing) interface on the remote router (or the logical interface representing the dialer profile) and select 'Non-Persistent Connection Setup, Connect With <Dialup_Link model>.'

Note: If you are making use of a dialer profile on the remote router, use the logical interface model representing the dialer. If you are not using a dialer profile on the remote router, use the interface model that represents the dialing interface.

3. Specify a primary interface for each Dialup_Link model. In the event that the primary interface goes down, the secondary link represented by the Dialup_Link model will activate:
 - a. Select the Dialup_Link model and click the Information tab in the Component Detail panel.
 - b. Expand the Primary and Secondary Interface Information subview.
 - c. In the Primary Interfaces table, click  (Add).
 - d. Select one or more primary interfaces in the resulting dialog and click Add.
 - e. Repeat for each Dialup_Link model that is part of this non-persistent connection configuration.
4. Associate each Dialup_Link model to the secondary (receiving) interfaces on the host router or routers.
 - a. Right-click the Dialup_Link model and select 'Non-Persistent Connection Setup, Start Non-Persistent Connection.'
 - b. Right-click the appropriate secondary (receiving) interface on the host router and select 'Non_Persistent Connection Setup, Connect With <Dialup_Link model>.'
 - c. Repeat for each Dialup_Link model that is part of this non-persistent connection configuration.

More information:

[Create Dialup Link Models](#) (see page 8)

Monitoring a Dialer Profile Connection

The logical interface model may behave in different ways when a call is activated. This behavior is often dependent on the particular router supporting the given dialer profile.

The status indicator on the logical interface model icon may display OFF even when the connection is live. The logical interface model icon may also move from the physical layer of the device topology view and stack itself on the PPP encapsulation layer interface model. You can locate the model by drilling down from the physical interface, to the bearer channel layer, to the PPP encapsulation layer, and then to the dialer interface. All of these behaviors are normal, but may differ depending on the device modeled. Therefore, you should rely on the Dialup_Link model status and the views presented in Monitoring Non-Persistent Connections to monitor your connection.

More information:

[Monitoring Non-Persistent Connections](#) (see page 23)

Multiple Dial Backup Links

This section discusses modeling a non-persistent connection that lets you have variable or unspecified links between a remote router and a host router. There could be multiple remote routers linking to a single host router or a single remote router linking to multiple host routers.

A single Dialup_Link model can support configurations that include multiple secondary links. Only one Dialup_Link model is needed to monitor multiple secondary connections, because only a single active secondary connection can exist between the host router and the remote router at one time.

Multiple Dial Backup Links (MDBLs) are used in either of the following scenarios:

- Multiple remote routers each with a dial backup link that connects to a common host router.
- A single remote router with a dial backup link that could connect to one of several host routers.

How to Model Multiple Remote Routers to a Common Host Router

The following image shows three remote routers (devices B, C, and D) using one interface on a host router (Interface 4 of Device A) to provide redundant support for their primary links.

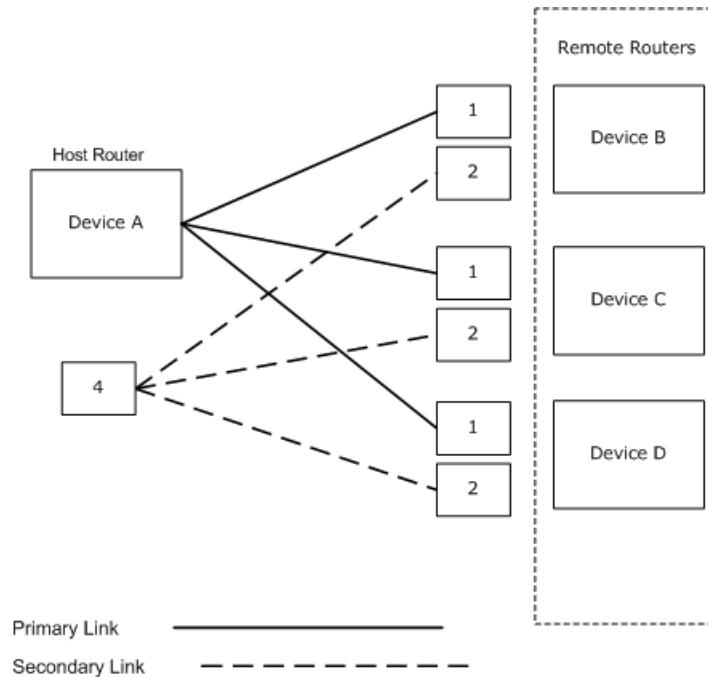

There are three main tasks involved in creating this configuration:

1. Configure the secondary interfaces on the remote routers by resolving the the Dialup_Link model to the secondary interfaces on each remote router.
2. Configure the appropriate primary interfaces. When you configure a primary interface, you associate the secondary link to the primary link or links it is supporting. This is done in the Dialup_Link model's Primary Interfaces subview in the Component Detail panel.

Note: CA Spectrum automatically affiliates the secondary interface configured on a device with the primary interface configured on the device, so that if this primary interface fails, the proper secondary connection will be monitored.

3. Configure the fixed secondary interface on the host router. This involves resolving the Dialup_Link model to the secondary interface of the host router.

How to Model a Single Remote Router to Multiple Host Routers or Host Router Interfaces

The following diagram shows a remote router (device C) which has secondary links established with two host routers (devices A and B) to provide redundant support for the primary link between device A and device C. When the secondary link becomes active, it will connect with either router A or router B. Before the connection is actually made, you cannot determine which of these routers the link will connect to.

The same scenario exists if the redundant link could connect to one of several interfaces on a host router or routers. In all of these cases, the connection to the host routers is resolved at the device level.

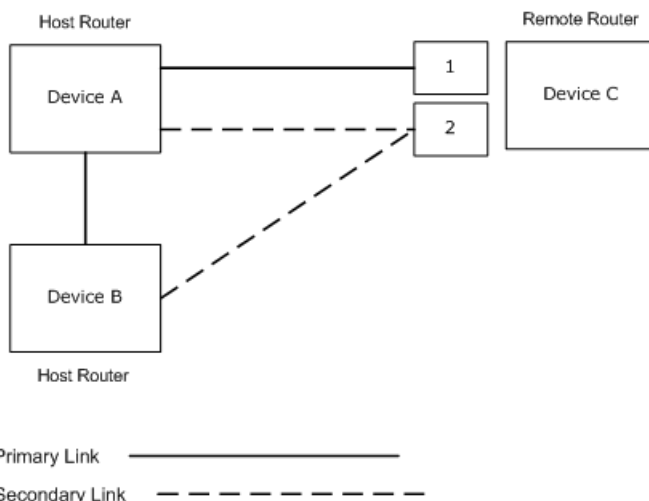

There are three main tasks involved in creating this configuration:

1. Configure the secondary interface on the remote router. This involves resolving the Dialup_Link model to the secondary interface.
2. Configure the appropriate primary interface. When you configure a primary interface, you associate the secondary link to the primary link it is supporting. This is done in the Dialup_Link model's Primary Interfaces subview in the Component Detail panel.
3. Configure the connection to the host router. This involves resolving the Dialup_Link model to the secondary interface on the host router. If it is unknown which host router or host router interface the remote router will connect to, resolve the dialup connection to the device level rather than the interface level.

Chapter 3: Monitoring Non-Persistent Connections

This section contains the following topics:

[Viewing Dialup_Link Model Information](#) (see page 23)

[Searching for Non-Persistent Connections](#) (see page 26)

[Determining the Status of Multiple Primary or Secondary Links](#) (see page 27)

[Dialup_Link Condition Colors](#) (see page 27)

[Alarms](#) (see page 29)

Viewing Dialup_Link Model Information

Once you have configured the Dialup_Link model connections and specified the interface on the remote router for the primary connection, the Dialup_Link model is fully integrated into the current modeling scheme and reacts according to the type of link it represents. The Topology view containing the Dialup_Link model shows live pipes connecting the Dialup_Link model to the remote and host routers.

These live pipes will have a brown condition when the dialup link is inactive. If the modeled primary link and secondary links involve the same two devices, the topology configuration involving the host and remote routers should look similar to the following image:

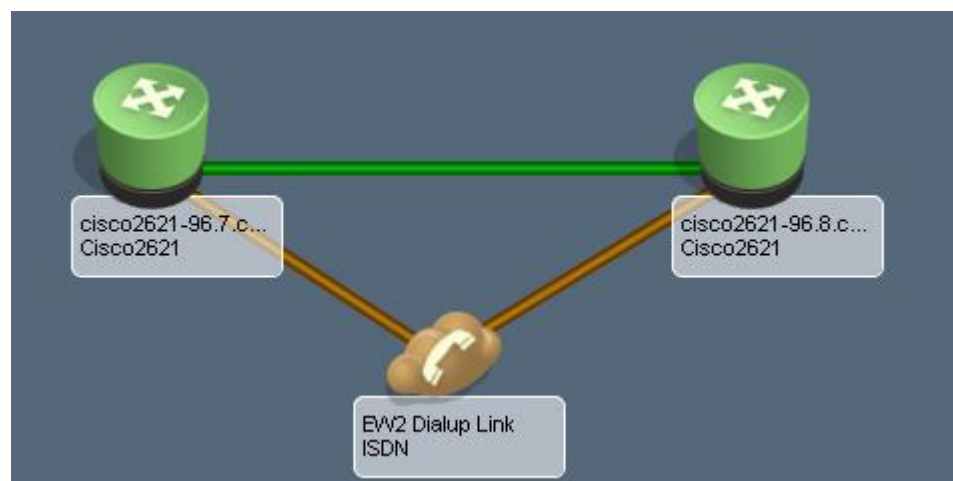

You access information about the creation, current settings, and status of the Dialup_Link model by selecting the model and then clicking the Information tab in the Component Detail panel. The Information tab displays the following views for Dialup_Link models:

- General Information
- Thresholds and Watches
- Primary and Secondary Interface Information:

Primary Interfaces

The Primary Interfaces list includes all currently configured primary interfaces on all devices associated with this Dialup_Link model.

Secondary Interfaces

The Secondary Interfaces list includes all currently configured secondary interfaces on all of the devices associated with this Dialup_Link model.

The Primary and Secondary Interface Information view contains the Primary Interfaces view and the Secondary Interfaces view.

Primary Interfaces

Contains information about the primary interfaces set up on this Dialup_Link model. This is a left/right list that lets you select interfaces on the devices associated to the Dialup_Link model. Ideally, this list should contain only interfaces on the dialing/remote device.

If more than one primary interface on a single remote router has been configured, these interfaces will be treated as a group. The status of the group of primary interfaces is determined by the healthiest group member. The backup interface will activate only if all of the primary interfaces in the group fail.

Secondary Interfaces

Contains information about the secondary interfaces setup on this Dialup_Link model.

The tables in both of these views display the following information by default:

Name

Specifies the name of the interface.

Condition

The contact status for the device, in addition to any alarm conditions in effect for the device model. Specifies the current condition of the interface.

Status

Indicates whether the interface is operational or non-operational. An interface may be non-operational for a variety of reasons including being administratively disabled. Some of the possible values include up, down, off, and dormant.

Type

Specifies the physical layer interface standard that the interface uses, such as ppp, ethernet, frameRelay, and so on.

Description

Describes whether the interface is physical or logical, and the interface ID, such as et.2.1.

Device Connected

The name and status (green for up or red for down) of the device that the current interface is connected to. The device name is a hyperlink that displays the Information tab for the connected device.

Port Connected

Specifies the name of the port on the device that the current port is connected to. The port name is a hyperlink that displays the Interfaces tab for the device that the current port is connected to.

QoS Policy

Specifies the QoS policy name that applies to this interface.

Index

Specifies the value of the index object in the standard RFC or proprietary MIB that uniquely identifies this interface within the device.

Board.Port

Identifies the board and port number on the device for the corresponding port. For example if the port is port 4 on a module in the device's third slot, the Board.Port value is 3.4.

More information:

[Dialup_Link Condition Colors](#) (see page 27)

Searching for Non-Persistent Connections

From the Locator tab, you can run the following two searches specific to non-persistent connections:

Active Non-Persistent Connections

The Active Non-Persistent Connections search returns a list of all Dialup_Link models that are currently active in a landscape.

All Non-Persistent Connections

The All Non-Persistent Connections search returns a list of every Dialup_Link model in the landscape, even if they are currently inactive.

Each results list contains the following information:

Condition

Identifies the current condition of the Dialup_Link model.

Note: See *Modeling and Managing Your IT Infrastructure Administrator Guide* for more information about condition colors.

Name

Specifies the name of the Dialup_Link model.

Dialup From

Specifies the name of the remote router model.

Dialup To

Specifies the name of the host router model.

Link Activation Start Time

Indicates at what time the Dialup_Link model became active, or whether it is inactive. For example, when the Dialup_Link model was connected to the appropriate interfaces.

Link Activation Duration

Indicates the length of time that the connection has been active.

Dialup Link Type

Specifies the type of link between the two points. Possible types are Backup (DBL), Primary (PODL), and Bandwidth (BODL).

Dialup Protocol Type

Specifies the protocol type to used by the Dialup_Link. Possible protocol types include Analog, Switch-56, ISDN, Frame_Relay, and Other.

More information:

[Non-Persistent Connection Types](#) (see page 8)

[Dialup_Link Condition Colors](#) (see page 27)

Determining the Status of Multiple Primary or Secondary Links

You can model non-persistent connections using multiple primary or secondary interfaces. When multiple primary interfaces are used, the status of the group is always determined using the following rule: If any of the interfaces are up, then the group is up; otherwise, the group is down.

Multiple secondary links use the DecSecGrpActiveCriteria attribute to determine the status of the group. If the value is AnySecondaryIFActive, and at least one of the secondary interfaces is up, then the group is considered to be up. Otherwise, the group is considered to be down.

Multiple primary links operate in the same way. If the value of the DecSecGrpActiveCriteria attribute is AllSecondaryIfsActive, all of the interfaces must be up for the group to be considered up. If not, then the group is considered to be down.

When one or more interfaces in the multiple link scenario is in maintenance mode, CA Spectrum will treat it as if that link does not exist, and base the status of the group on the remaining non-maintenance interfaces. The exception is if all interfaces are in maintenance mode, then the entire group is in maintenance mode.

Dialup_Link Condition Colors

The way in which the Dialup_Link model reacts to changes in the primary and secondary links depends upon the type of non-persistent connection this model represents. The following tables show the possible conditions for the Dialup_Link model representing a Dial Backup Link, Bandwidth on Demand Link, or a Primary On Demand Link.

Dial Backup Link Conditions

Primary Link	Secondary Link	Dialup_Link	Generated Events
Up	Up	Yellow	Both primary and secondary links are active.
Up	Down	Brown	Secondary link inactive.

Primary Link	Secondary Link	Dialup_Link	Generated Events
Up	Up	Yellow	Both primary and secondary links are active.
Down	Up	Green	Secondary link active.
Down	Down	Red	Secondary link has failed to activate.
Maintenance Mode	Up	Green	Secondary link active.
Maintenance Mode	Down	Brown	Secondary link inactive.
Up	Maintenance Mode	Brown	Secondary link inactive.
Down	Maintenance Mode	Brown	Secondary link inactive.

Bandwidth On Demand Link Conditions

Primary Link	Secondary Link	Dialup_Link Condition	Generated Events
Up	Up	Green	None.
Up	Down	Brown	Secondary link is inactive.
Down	Up	Green	Secondary link is active.
Down	Down	Red	Secondary link has failed to activate.
Maintenance Mode	Up	Green	Secondary link active.
Maintenance Mode	Down	Brown	Secondary link inactive.
Up	Maintenance Mode	Brown	Secondary link inactive.
Down	Maintenance Mode	Brown	Secondary link inactive.
Maintenance Mode	Maintenance Mode	Brown	Secondary link inactive.

Primary On Demand Link Conditions

Primary Link	Dialup_Link Condition	Generated Events
Up	Green	No event is generated. Primary On Demand link is active.
Down	Brown	No event is generated. Primary On Demand link is inactive.
Up	Yellow	The maximum uptime value has been exceeded.
Maintenance Mode	Brown	No event is generated. Primary On Demand link is inactive.

There are two exceptions to these Dialup_Link Condition tables. These involve these special alarm conditions: Gray and Orange.

- A Gray condition is asserted on a Dialup_Link model when all secondary interfaces are considered unreachable.
- An Orange condition is asserted only in a multiple primary/secondary configuration when a primary link has failed but the secondary link is already active in support of another connection.

Alarms

The Thresholds and Watches view in a Dialup_Link model's Information tab lets you configure when alarms will be generated on the Dialup_Link model for certain conditions. To access the Thresholds and Watches view, click the Dialup_Link model, click the Information tab, and then expand the Thresholds and Watches subview.

Activation Grace Period (Minutes)

Lets you specify the time allowed, in minutes, for the secondary link to become active after a primary link failure. If this grace period expires before the secondary link is active, then a red alarm is generated. This field is only used by DBL-type link models. The value for this field can also be specified when creating a Dialup_Link model.

Deactivation Grace Period (Minutes)

Specifies the time allowed, in minutes, for an active secondary link to deactivate after the failed primary link reactivates. If the secondary link is still active after this grace period expires, then a yellow alarm is generated. This field is only used by DBL-type link models. The value for this field can also be specified when creating a Dialup_Link model.

Active Time Until Yellow (Hours)

Specifies the number of hours a backup link can be active before a yellow alarm is generated. The value for this field can also be specified when creating a Dialup_Link model.

Active Time Until Orange (Hours)

Specifies the number of hours a backup link can be active before an orange alarm is generated. The value for this field can also be specified when creating a Dialup_Link model.

Active Time Until Red (Hours)

Specifies the number of hours a backup link can be active before a red alarm is generated. The value for this field can also be specified when creating a Dialup_Link model.

Active Criteria

Specifies the active state for non-persistent connections that have more than one secondary interface, i.e. a connection that uses multiple physical connections to form one logical connection. When this multi-link type configuration is used, the Dialup_Link model will monitor all the secondary interfaces. If Active Criteria is set to Any Secondary IF Active then the dial-up link will be considered "active" if ANY of the secondary interfaces become active. If Active Criteria is set to All Secondary IFs Active then ALL the secondary interfaces must become active before the Dialup_Link model will be considered "active."

The following shows the alarms that CA Spectrum can generate on a Dialup_Link model.

Note: Events generated on a Dialup_Link model have an event message which contains information on the devices and interfaces that the Dialup_Link model is connected to.

Alarm Code	Alarm	Alarm Cause
0x022ffff8	Excess timer has been exceeded.	The link has been active for longer than the time specified by the Active Until Yellow, Orange or Red criteria.
0x022ffff9	Backup link is already active.	This alarm occurs when CA Spectrum attempts to activate a dialup link that is already active.
0x022ffffa	Both the primary and the secondary links are active.	Both the primary and the secondary links have been activated.

Alarm Code	Alarm	Alarm Cause
0x022ffffb	The secondary link failed to activate.	An attempt to activate the secondary link was unsuccessful.
0x022ffffc	The secondary link is inactive.	The primary link is functioning properly and the secondary link has returned to an inactive status.
0x022ffffd	The Dialup_Link model is unreachable.	This alarm is generated when all of the Dialup_Link model's neighbors are down. Neighbors include any interface model or device model to which the Dialup_Link model has a resolved connection.

More information:

[Create Dialup_Link Models](#) (see page 8)

Index

C

connections, non-persistent • 7

D

Dialup_Link model • 7, 8, 20, 22

L

load balancing • 7

M

Multiple Dial Backup Links • 20

S

Security String • 8

U

unspecified links • 20