

CA Spectrum[®] Infrastructure Manager

ATM Circuit Manager User Guide

r9.2



This documentation and any related computer software help programs (hereinafter referred to as the "Documentation") are for your informational purposes only and are subject to change or withdrawal by CA at any time.

This Documentation may not be copied, transferred, reproduced, disclosed, modified or duplicated, in whole or in part, without the prior written consent of CA. This Documentation is confidential and proprietary information of CA and may not be used or disclosed by you except as may be permitted in a separate confidentiality agreement between you and CA.

Notwithstanding the foregoing, if you are a licensed user of the software product(s) addressed in the Documentation, you may print a reasonable number of copies of the Documentation for internal use by you and your employees in connection with that software, provided that all CA copyright notices and legends are affixed to each reproduced copy.

The right to print copies of the Documentation is limited to the period during which the applicable license for such software remains in full force and effect. Should the license terminate for any reason, it is your responsibility to certify in writing to CA that all copies and partial copies of the Documentation have been returned to CA or destroyed.

TO THE EXTENT PERMITTED BY APPLICABLE LAW, CA PROVIDES THIS DOCUMENTATION "AS IS" WITHOUT WARRANTY OF ANY KIND, INCLUDING WITHOUT LIMITATION, ANY IMPLIED WARRANTIES OF MERCHANTABILITY, FITNESS FOR A PARTICULAR PURPOSE, OR NONINFRINGEMENT. IN NO EVENT WILL CA BE LIABLE TO THE END USER OR ANY THIRD PARTY FOR ANY LOSS OR DAMAGE, DIRECT OR INDIRECT, FROM THE USE OF THIS DOCUMENTATION, INCLUDING WITHOUT LIMITATION, LOST PROFITS, LOST INVESTMENT, BUSINESS INTERRUPTION, GOODWILL, OR LOST DATA, EVEN IF CA IS EXPRESSLY ADVISED IN ADVANCE OF THE POSSIBILITY OF SUCH LOSS OR DAMAGE.

The use of any software product referenced in the Documentation is governed by the applicable license agreement and is not modified in any way by the terms of this notice.

The manufacturer of this Documentation is CA.

Provided with "Restricted Rights." Use, duplication or disclosure by the United States Government is subject to the restrictions set forth in FAR Sections 12.212, 52.227-14, and 52.227-19(c)(1) - (2) and DFARS Section 252.227-7014(b)(3), as applicable, or their successors.

Copyright © 2010 CA. All rights reserved. All trademarks, trade names, service marks, and logos referenced herein belong to their respective companies.

CA Technologies Product References

This guide references CA Spectrum® Infrastructure Manager (CA Spectrum).

Contact CA Technologies

Contact CA Support

For your convenience, CA Technologies provides one site where you can access the information you need for your Home Office, Small Business, and Enterprise CA Technologies products. At <http://ca.com/support>, you can access the following:

- Online and telephone contact information for technical assistance and customer services
- Information about user communities and forums
- Product and documentation downloads
- CA Support policies and guidelines
- Other helpful resources appropriate for your product

Provide Feedback

If you have comments or questions about CA Technologies product documentation, you can send a message to techpubs@ca.com.

If you would like to provide feedback about CA Technologies product documentation, complete our short customer survey, which is available on the CA Support website at <http://ca.com/docs>.

Contents

Chapter 1: ATM and CA Spectrum Modeling Concepts	7
ATM Technology	7
ATM Circuit Manager	8
ATM Model Types	9
ATM_Cloud	10
ATM_Network	10
ATMVplLink and ATMVclLink	11
UnmanAtmLink	11
ATM Network Topologies	11
Chapter 2: Modeling the ATM Network	15
How to Create an Accurate Model of Your ATM Network	15
Physical Components Modeling in the ATM Network	15
Physical Components Modeling Using Discovery	16
Manual Physical Components Modeling	16
Connect Physical Interfaces to Service Provider's Network	17
Modeling the Virtual Interfaces in the ATM Network	18
Required MIBs	19
Specify Virtual Links to Model for a Device	20
Specify Frequency for Updating Virtual Link Models	22
Logical Connections Links between Virtual Link Models	22
Create Pipes Between Virtual Link Models	27
Chapter 3: Monitoring and Managing the ATM Network	29
About ATM Monitoring and Management	29
Monitor the Logical Connections Between Virtual Link Models	30
Monitor Virtual Link Models	31
View Virtual Link Models Performance	32
Set Traffic Thresholds for Virtual Link Models	34
Specify Service Information for Virtual Link Models	36
Specify Service Information for unmanATMLink model	37
Monitor Quality of Service (QoS) Information for VCLs	38
Receive and Transmit QoS Parameters	39
Bandwidth Parameters	40
Graphical Representations of ATM Interface Connections	41

Chapter 4: Managing Faults	43
Fault Management Overview	43
Fault Management Using Link Status	43
Manage Faults Using Threshold Alarms	44
Fault Management on Cisco Routers	45
Configure CiscoPingApp Application Model	46
Fault Isolation Across Switched Fabric	47
Glossary	51
Index	53

Chapter 1: ATM and CA Spectrum Modeling Concepts

This section contains the following topics:

[ATM Technology](#) (see page 7)

[ATM Circuit Manager](#) (see page 8)

[ATM Model Types](#) (see page 9)

[ATM Network Topologies](#) (see page 11)

ATM Technology

Asynchronous Transfer Mode (ATM) is a connection-oriented, network communication architecture that transmits data through pre-established virtual channels called circuits that are similar to telephone calls. Circuits can be established automatically by switched virtual circuit (SVC) signaling, or they can be set up manually to form permanent virtual circuits (PVCs).

ATM is based on the transmission of fixed-length (53-byte) cells of data. ATM's use of small, fixed-length data cells allows for improved traffic management and traffic shaping. Each ATM cell contains a 5-byte header and 48 bytes of payload. The header includes a virtual path identifier (VPI) and a virtual channel identifier (VCI). These identifiers are used by ATM switches to determine the correct channels on which to transmit particular cells. Transmission is controlled by statistical multiplexing, which awards bandwidth (channels) to devices on a first come, first serve basis.

The combination of small, fixed-length data cells and the efficient use of bandwidth enable ATM switches to communicate time-critical video and audio data, as well as other computer data, across the ATM network. In an end-to-end transmission across a mixed LAN/ATM/LAN network, packets transmitted by a LAN workstation to an ATM switch are segmented into cells for high speed transmission through ATM channels. At the destination, the cells are then reassembled into packets for use by another LAN workstation.

ATM Circuit Manager

CA Spectrum's ATM Circuit Manager lets you model both the physical and logical connectivity of your ATM infrastructure. You can represent an ATM infrastructure that you own and manage, or one that is partially or fully owned and managed by a service provider. The following illustration shows a sample modeled ATM network that includes partial management by a service provider.

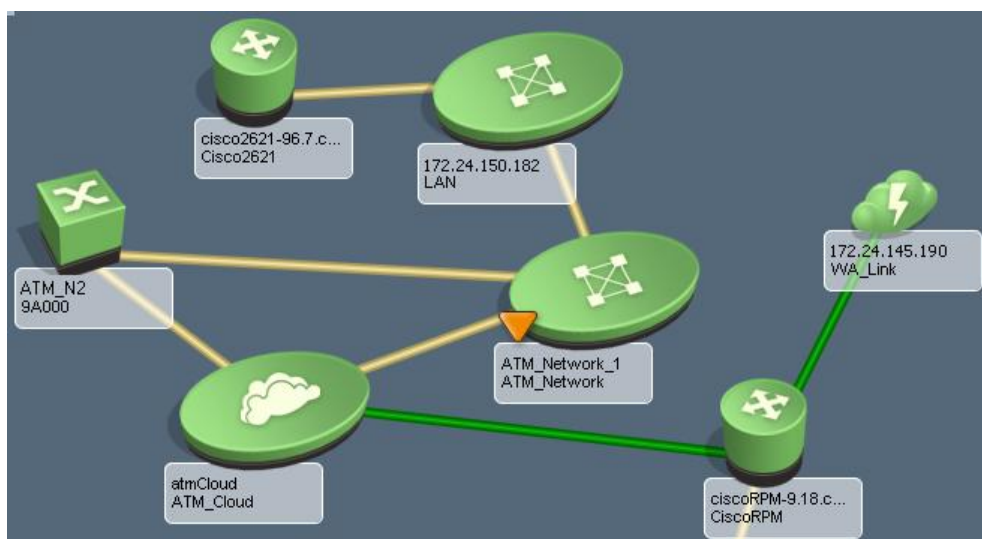

In a fully or partially meshed ATM network, each physical ATM interface may have logical connections with many other ATM devices. However, without ATM Circuit Manager, CA Spectrum's modeling functionality will only model physical ATM interfaces, leaving logical ATM interfaces unmanaged and limiting connectivity to physical links. Therefore, without ATM Circuit Manager, it is impossible to accurately represent the logical connectivity of the switches and routers in the ATM network.

The physical connectivity of an ATM network is represented by *Connects_to* associations between the ATM physical interface models and the connected device models. This lets you represent true data relay paths between the clients and helps ensure proper fault isolation. You can represent the physical connectivity of the ATM network by connecting a physical ATM interface model to another physical interface model, to a device model, or to an ATM_Cloud model.

The logical connectivity of an ATM network is represented by logical connections between virtual link models. These virtual link models represent the endpoints of a virtual connection. Virtual link models include VPLs (virtual path links, also referred to as virtual path trunks or VPTs) and VCLs (virtual channel links). Virtual link models are associated with a lower-layer interface model using the HASPART relation. The lower-layer interface may be a physical ATM interface model, or, in the case of a VCL, it may be a VPL or VPT model.

The following illustration shows the relationships between the modeled physical and virtual components in an ATM network.

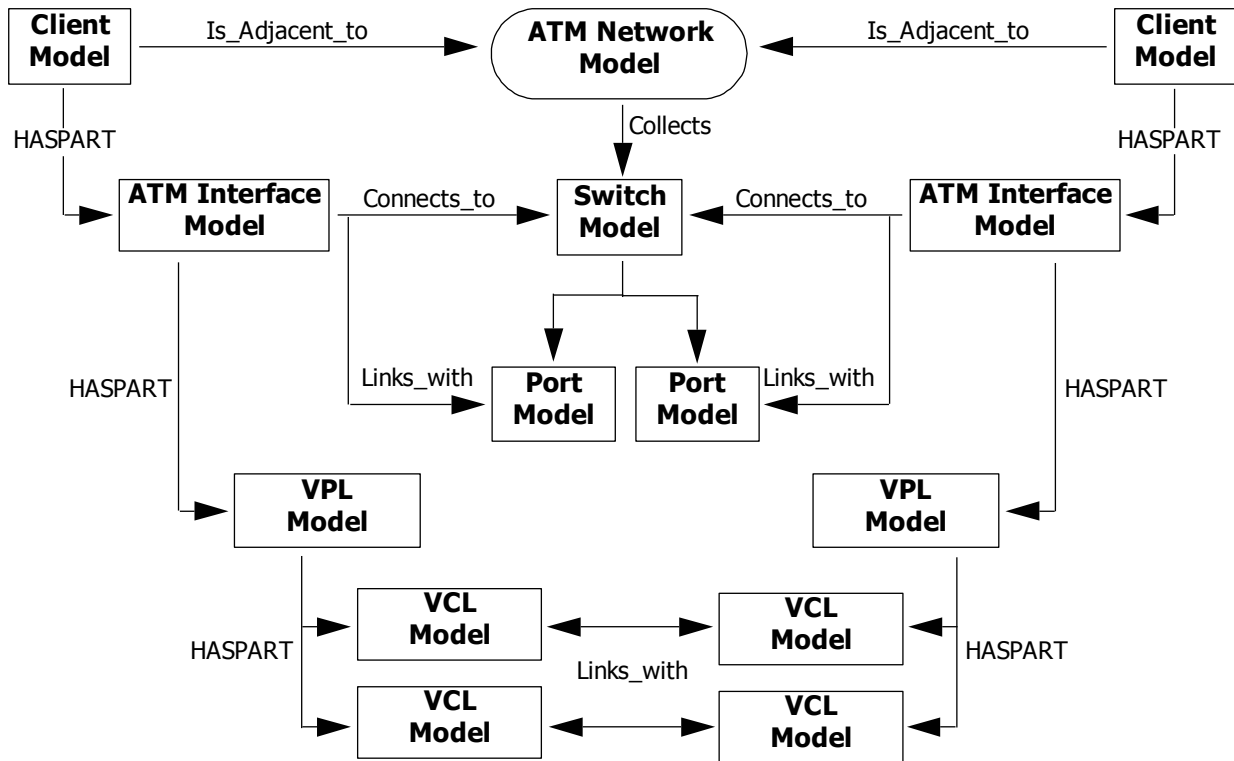

Note: An actual ATM network would contain (collect) multiple switches. For simplicity, the illustration shows just one switch.

Once you have modeled your ATM network, you can use ATM Circuit Manager to isolate faults within the network, evaluate performance, and monitor quality of service.

ATM Model Types

ATM Circuit Manager uses several model types to enable you to accurately represent your ATM infrastructure. These include ATM_Cloud, ATM_Network, ATMvpLink, ATMvcLink, and UnmanAtmLink.

ATM_Cloud

The ATM_Cloud model type is used in modeling situations where a service provider supplies wide area connectivity to remote sites using ATM links that are leased channels or paths. There is no management access to the service provider's network. In this scenario, management of the ATM links must be provided by the ATM clients also referred to as ATM Edge devices and/or ATM switches connected to the service provider's equipment.



If the devices connected to a cloud have their virtual interfaces modeled (as VPLs/VPTs, VCLs, or both), you can use the interfaces to create logical connections between endpoints.

More information:

[Create Logical Connections Manually](#) (see page 23)

ATM_Network

The ATM_Network model type is used in modeling situations where the ATM switched fabric is completely managed.



If the devices within the network and the devices connected to it have their virtual interfaces modeled (as VPLs/VPTs, VCLs, or both), you can use the interfaces to create logical connections between endpoints.

More information:

[Create Logical Connections Manually](#) (see page 23)

ATMVplLink and ATMVclLink

The ATMVplLink model type represents a VPL/VPT, and the ATMVclLink model type represents a VCL. These virtual link models represent the endpoints of a virtual connection, and connectivity between them represents the logical connectivity of the ATM network.

Management of the PVPs and PVCs in the ATM network is achieved by polling the attributes of VPL/VPT and VCL models. CA Spectrum uses this data to do the following:

- Monitor circuit status and other statistics
- Generate alarms based on the status of a model, for example, when the load on the model exceeds a predefined threshold

In OneClick, you can view a device's physical interface models and virtual link models on the Interfaces tab. The virtual link models in the table are identified by interface type (atmLink and, more specifically, VPL, VPT, or VCL). You can identify the underlying model type of a specific virtual link model by displaying the value for Modeltype_Name using the Attributes tab.

UnmanAtmLink

Some ATM paths or circuits may be manageable from only one endpoint. The device on one side may not have an SNMP agent, may be inaccessible for some reason, or you simply may not have management of the device. If this is the case, you can create a model of type UnmanAtmLink to represent the unmanaged endpoint, and then include the unmanaged model in a logical connection with a managed endpoint.

More information:

[Create Logical Connections to Unmanaged Models](#) (see page 24)

ATM Network Topologies

There are four typical ATM infrastructure scenarios:

1. You own and administer the switches and clients that comprise the ATM infrastructure.
2. You use a completely leased network through an ATM service provider to provide wide-area connectivity, and you have no management access to the ATM switched fabric.

3. You use a completely leased network through a service provider, and you have a mixture of ATM and Frame Relay interfaces on either side of the leased network.
4. You own and manage your own local area ATM network and lease additional wide-area channels through a service provider's network.

The following subtopics explain how the ATM-related model types are used to represent these different types of ATM infrastructures. For an illustration of the associations that are described, see [ATM Circuit Manager](#) (see page 8).

A Completely Owned ATM Network

If you own your ATM switches, you will use an ATM_Network model to represent the switched fabric. Switch models will appear within the ATM_Network model and have a *Collects* association with that model. Client models will have an *Is_Adjacent_to* association with the ATM_Network model because the connection between the clients and the switches within the network have been fully modeled at the physical interface level.

A Completely Leased ATM Network

If an ATM service provider supplies wide-area connectivity to remote sites, there is no management access to the service provider's ATM switches. The ATM clients must provide all of the data to monitor the ATM circuits. To support the modeling of this type of network, an ATM_Cloud model is used. All ATM interfaces that connect to the service provider's network will have a *Connects_to* association with the ATM_Cloud model. This modeling association can be established manually as described in *Connecting the Physical Interfaces to the Service Provider's Network*.

An ATM to Frame Relay Network

It is possible to have a hybrid ATM network that includes multiple Frame Relay to ATM links over a completely leased network. In this scenario, signals transmitted from a local ATM interface through the service provider's network are converted to Frame Relay by a translational bridge before being received by the remote Frame Relay interface, and vice versa. The modeling procedure for this scenario is identical to that for modeling an ATM to ATM logical connection over a completely leased network.

A Completely Owned ATM Switched Fabric with Leased ATM Wide-Area Channels

If you own your local ATM switches, but you connect to a service provider's network for wide-area access, the physical interface(s) of one or more ATM switches may be connected to the ATM_Cloud model. In this case, CA Spectrum intelligence will automatically create VPL and VCL models to represent the VPLs and VCLs of a physical interface connected to the ATM_Cloud model. If the ATM switches are modeled within an ATM_Network, the ATM_Network model will be adjacent to the ATM_Cloud model.

More information:

[ATM Circuit Manager](#) (see page 8)

[Connect Physical Interfaces to Service Provider's Network](#) (see page 17)

Chapter 2: Modeling the ATM Network

This section contains the following topics:

[How to Create an Accurate Model of Your ATM Network](#) (see page 15)

[Physical Components Modeling in the ATM Network](#) (see page 15)

[Modeling the Virtual Interfaces in the ATM Network](#) (see page 18)

How to Create an Accurate Model of Your ATM Network

To create an accurate model of your ATM network, you must perform the following high-level tasks:

1. Model the physical elements and physical connectivity in the network using Discovery or manually.
2. Connect the physical ATM interfaces to the service provider's network.
3. Model the logical connectivity between virtual path links (VPLs, also referred to as virtual path trunks or VPTs) and virtual channel links (VCLs).

Note: This guide refers to VPLs and VCLs, collectively, as virtual link models.

4. Create logical connections between the virtual link models. You can create the connections using Discovery (for VCLs on Cisco devices only), create the connections manually, or import them using a file that defines them.

More information:

[Physical Components Modeling in the ATM Network](#) (see page 15)

[Connect Physical Interfaces to Service Provider's Network](#) (see page 17)

[Specify Virtual Links to Model for a Device](#) (see page 20)

[Logical Connections Links between Virtual Link Models](#) (see page 22)

Physical Components Modeling in the ATM Network

To model the ATM circuits correctly, the physical connectivity must be modeled first. You can do this using Discovery or manually. If you use Discovery, you may need to manually customize the results to verify that the model accurately represents the network infrastructure.

Physical Components Modeling Using Discovery

When you use Discovery to model the physical components in an ATM network, and you select in the Protocol Options dialog that ATM protocols be used to map the connectivity between models, Discovery maps the physical connectivity between the ATM devices and places ATM switch models inside ATM_Network container models.

If Discovery does not fully map the physical ATM connectivity of your network, including switch-to-switch and router-to-switch connections, you must rerun Discovery or complete the mapping manually.

Note: Discovery does not create ATM_Cloud models to represent the ATM networks of service providers. After you model your network using Discovery, you must create these models manually and then name them appropriately (for example, Sprint's Network).

If you are using Cisco ATM devices and the VCL interfaces have unique IP addresses, Discovery also resolves the connections between VCL interfaces or between VCL interfaces and Frame Relay DLCI interfaces.

Note: For complete information on modeling using Discovery, see the *Modeling and Managing Your IT Infrastructure Administrator Guide*.

Once you have modeled the physical components and connections in the ATM network, you can then model the logical connectivity between virtual path links (VPLs, also referred to as virtual path trunks or VPTs) and virtual channel links (VCLs).

More information:

[Connect Physical Interfaces to Service Provider's Network](#) (see page 17)

[Specify Virtual Links to Model for a Device](#) (see page 20)

[Logical Connections Links for Cisco Devices Using Discovery](#) (see page 23)

Manual Physical Components Modeling

You may need to manually model the ATM infrastructure for various reasons:

- You prefer to manually create all ATM models and connections.
- You have used Discovery to model the devices and map their physical connectivity, but you now need to make some manual modifications to make the network representation fully accurate.
- You have used Discovery to model the ATM infrastructure, but you now need to create ATM_Cloud models to represent the ATM networks of service providers. Discovery does *not* create these models.

After you manually model the devices, you can create connections between container models, device models, and physical interface models. You can connect the physical ATM interface models directly to the switch or client models, but they must be collected by an ATM_Network model to have access to the Logical Connection Table.

Note: For complete information on manually modeling devices and connections, see the *Modeling and Managing Your IT Infrastructure Administrator Guide*.

After you model the physical components and connections in the ATM network, you can then model the logical connectivity between virtual path links (VPLs, also referred to as virtual path trunks or VPTs) and virtual channel links (VCLs).

More information:

[Specify Virtual Links to Model for a Device](#) (see page 20)

[Create Logical Connections Manually](#) (see page 23)

Connect Physical Interfaces to Service Provider's Network

In order for CA Spectrum to accurately determine the point of an ATM network failure during fault isolation, every physical ATM interface that connects to the service provider's network should be connected to the ATM_Cloud model.

Connecting the physical ATM interfaces to the service provider's network is a manual step regardless of whether you have modeled the ATM network manually or used Discovery.

To connect an ATM interface to the service provider's network

1. On the Interfaces tab of the associated device, select the physical ATM interface to connect to the service provider's network, right-click, and click Start Connection.
2. On the Topology tab, select the ATM_Cloud model that represents the service provider's network, right-click, and click Connect With <ATM Interface Name>, where <ATM Interface Name> is the name of the interface you selected in the first step.

A pipe between the ATM_Cloud and the physical ATM interface (and the appropriate network container model) is created to represent the connection. You can double-click the pipe to view the connection between the ATM_Cloud and the physical ATM interface itself, as shown in the following example.

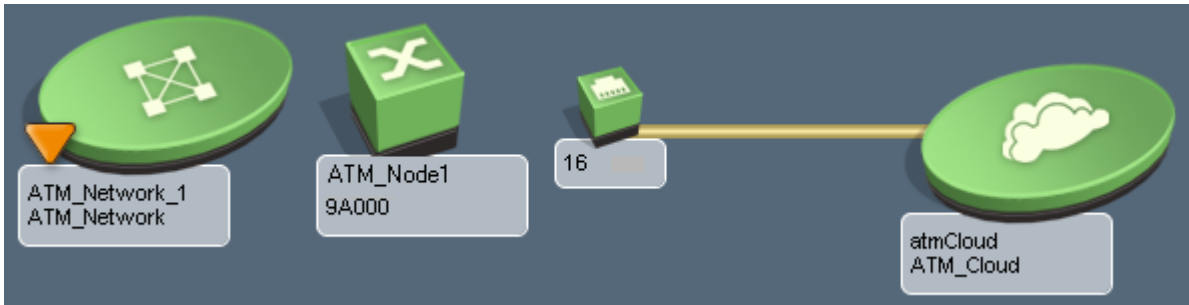

Modeling the Virtual Interfaces in the ATM Network

In CA Spectrum, physical connections between devices are managed by polling the status and performance data of the endpoints, such as FDDI or HSSI interfaces.

There is no difference between managing logical connections and managing physical connections except that the logical connection endpoints are Virtual Path Links (VPLs) or Virtual Channel Links (VCLs). This guide refers to VPLs and VCLs collectively as *virtual links*.

Like physical interfaces, virtual links have objects in a MIB that contain the status, bandwidth, and—depending on the MIB—performance statistics. Physical interfaces, as represented in the MIB-II *ifTable*, have a single-term index, but VPLs have a two-term index, and VCLs have a three-term index.

- A VPL index is in the form *ifIndex.VPI*, where *ifIndex* is the index of the physical interface that the VPL runs on, and *VPI* is the Virtual Path Identifier (the identifier given to the path when it was created).
- A VCL index is in the form *ifIndex.VPI.VCI*, where *VCI* is the Virtual Channel Identifier (the identifier given to the channel when it was created).

Virtual links can be modeled for all ATM clients and switches that have supported ATM MIBs.

Required MIBs

CA Spectrum can use different sets of SNMP MIBs to manage ATM links and logical connections. When CA Spectrum creates a device model to represent an ATM device, it also creates an application model based on the ATM MIBs that the device supports.

The following table lists the CA Spectrum management modules that support ATM devices, the MIBs required to support those devices, and the type of application model that is created to support the required MIBs.

Management Module	MIBs	Application Model Type
CA Spectrum Core Product	ATM-MIB	ATMClientApp
CA Spectrum Core Product	ATM-MIB ATM2-MIB ATM-FORUM-MIB	ATMSwitchApp
Bay Networks Centillion 100 (SM-BAY1001)	CENTILLION-ATMCFG-MIB	CentATMApp
Cisco Catalyst 85xx (SM-CAT1008)	ACCOUNTING-CONTROL-MIB ATM-MIB ATM-FORUM-MIB ATM-RMON-MIB CISCO-ATM-ACCESS-LIST-MIB CISCO-ATM-CONN-MIB CISCO-ATM-IF-MIB CISCO-ATM-IF-PHYS-MIB CISCO-ATM-RM-MIB CISCO-ATM-SERVICE-REGISTRY-MIB CISCO-ATM-SWITCH-ADDR-MIB CISCO-ATM-TRAFFIC-MIB CISCO-PNNI-MIB	CiscoSwitchApp
Cisco LightStream 1010 (SM-CIS1002)	ACCOUNTING-CONTROL-MIB ATM-MIB ATM-FORUM-MIB ATM-RMON-MIB CISCO-ATM-ACCESS-LIST-MIB CISCO-ATM-CONN-MIB CISCO-ATM-IF-MIB CISCO-ATM-IF-PHYS-MIB CISCO-ATM-RM-MIB CISCO-ATM-SERVICE-REGISTRY-MIB CISCO-ATM-SWITCH-ADDR-MIB CISCO-ATM-TRAFFIC-MIB CISCO-PNNI-MIB	LS_Switch_App

Management Module	MIBs	Application Model Type
Cisco Router (CIS-1000)	CISCO-AAL5-MIB	CiscoAAL5App
Cisco Stratacom BPX8600 and IGX8400 Series (SM-CIS1003)	STRATACOM-MIB	StComATMSwApp
ForeRunner ATM Switch Modules (SM-FOR1000)	Fore-Switch-MIB	ForeSwitchApp
Lucent Ascend CBX (SM-LUC1002)	CASCADE-MIB	CascadeATMApp
Nortel Passport Multiservice Carrier Switch Series (SM-NTL1005)	Nortel-MsCarrier-MscPassport-AtmCoreMIB	PpAtmClientApp
SmartSwitch 9000/9500 Series (SM-CSI1073)	ATM-MIB ATM2-MIB ATM-FORUM-MIB	PredSwitchApp

Specify Virtual Links to Model for a Device

CA Spectrum models the virtual links (VPLs and VCLs) on ATM devices by periodically reading the MIBs on the devices to determine the virtual links that currently exist. By default, ATM links (VPLs and VCLs) are modeled for ATM clients, and, for performance reasons, they are not modeled for ATM switches.

An exception to this default behavior is when a physical interface of an ATM switch is connected to an ATM_Cloud model. In this situation, the virtual links associated with that interface are modeled. These virtual links are necessary to resolve logical connectivity across the ATM_Cloud.

You can change the configuration of an ATM device so that only VPLs are modeled, both VPLs and VCLs are modeled, or so that no virtual links are modeled at all. The last option is especially useful if the virtual links for a device are dynamic (such as the case when SVCs are in use) and modeling them holds no inherent value.

Note: If a particular ATM device has a very large number of VCLs (in the order of thousands), modeling and reconfiguration of the virtual link models can impact SpectroSERVER performance.

To specify the virtual interfaces to model on an ATM device

1. Use the Navigation panel or the Topology tab to locate and select the device.
Information about the device is displayed in the Component Detail panel.
2. Click the Information tab in the Component Detail panel, expand Reconfiguration, and expand ATM Link Modeling Options and Reconfiguration.
3. Specify whether to model ATM links (virtual interfaces) for the device and, if so, whether to model only VPLs or both VPLs and VCLs:
 - To enable the modeling of ATM links, click set in the 'Create models to represent ATM links' field and select Enabled. Alternatively, if you do not want to model any ATM links, select Disabled instead. (By default, this option is enabled for ATM Client models and disabled for ATM Switch models.)
Note: If the ATM links for a device are currently modeled, and you disable this option, all existing ATM link models for the device will be deleted after you click 'Reconfigure ATM Link and Virtual Interface Models' in the next step.
 - To enable the modeling of virtual channel links (VCLs), click set in the 'Create models to represent VCLs' field and select Enabled. Alternatively, if you do not want to model VCLs, select Disabled instead.
Note: This option only controls the modeling of VCLs. If 'Create models to represent ATM links' is set to Disabled, this setting has no effect.
4. Click Reconfigure ATM Link and Virtual Interface Models.
CA Spectrum reads the MIBs on the devices to determine the virtual links that currently exist and then creates and destroys the virtual link models according to the settings you specified.

More information:

[Connect Physical Interfaces to Service Provider's Network](#) (see page 17)

[Monitor Virtual Link Models](#) (see page 31)

Specify Frequency for Updating Virtual Link Models

CA Spectrum models the virtual links (VPLs and VCLs) on ATM devices by periodically reading the MIBs on the devices to determine the virtual links that currently exist and then updates the virtual link models accordingly. If desired, you can change the interval at which this read operation is performed.

To specify the frequency for updating virtual link models

1. Use the Navigation panel or the Topology tab to locate and select the appropriate device.
Information about the device is displayed in the Component Detail panel.
2. Click the Information tab in the Component Detail panel, expand Reconfiguration, and expand ATM Link Modeling Options and Reconfiguration.
3. Click set in the Configuration Discovery Interval (sec) field, type a new time interval in seconds, and press Enter.

Logical Connections Links between Virtual Link Models

Virtual link models can have Links_ with associations with other virtual link models to indicate logical connections. A *managed virtual circuit* is a circuit whose virtual link models are associated by a logical connection. ATM circuits run from one client, through the ATM_Network, to another client, or directly between ATM switches within the switched fabric. By default, none of the circuits through the switched fabric are managed.

You can create logical connections (*Links_ with associations*) between virtual link models in the following ways:

- Use Discovery (Cisco devices only)
- Manually create the connections
- Import a file that defines the connections to create

CA Spectrum use the logical connection information during the fault isolation process.

More information:

[Fault Isolation Across Switched Fabric](#) (see page 47)

Logical Connections Links for Cisco Devices Using Discovery

When you run Discovery to model your ATM network, if the VCL interfaces on the Cisco ATM devices have unique IP addresses, CA Spectrum resolves the connections between these interfaces. If there are connections between Cisco VCL interfaces and Frame Relay DLCI interfaces, CA Spectrum also resolves these connections.

Note: For information on using Discovery, see the *Modeling and Managing Your IT Infrastructure Administrator Guide*.

Create Logical Connections Manually

You can include a virtual link in only one logical connection.

To manually create logical connections between virtual link endpoints

1. Use the Navigation panel or the Topology tab to locate and select the ATM_Cloud or ATM_Network model that is connected to or contains the relevant device and interface models.
2. Click the Information tab in the Component Detail panel, expand Logical Connection Table, and click Add.

The Logical Connection Manager dialog opens.

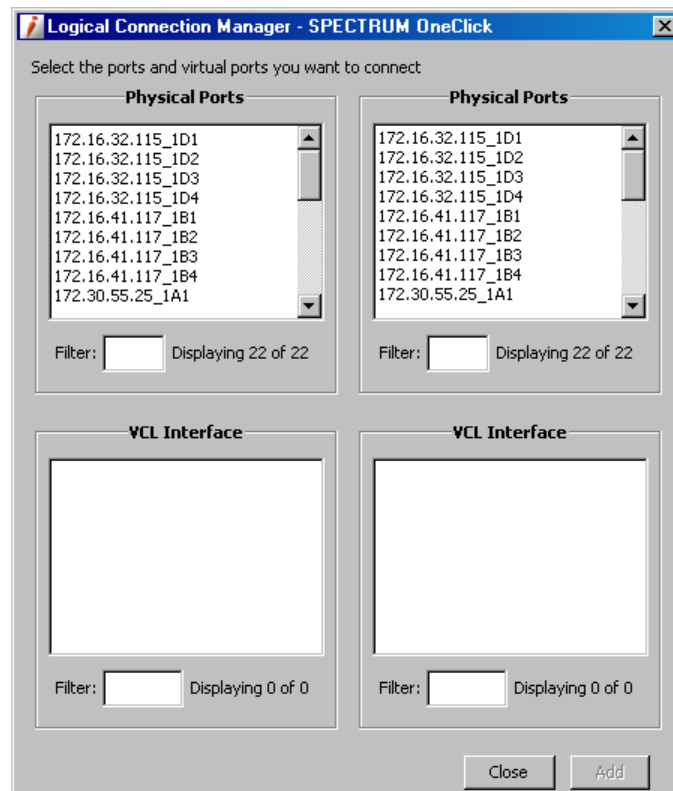

The dialog lists the physical ports on the ATM devices connected to the selected cloud, or connected to or contained within the selected network. Only the ports that currently have virtual link models are included in the lists.

3. Select one of the physical ports that contains the virtual link to connect in the left Physical Ports box.

The virtual interfaces for the selected port are displayed in the left VCL Interface box.

4. Select the virtual link that represents the first endpoint of the logical connection in the left VCL Interface box.
5. Repeat the Step 3 and Step 4 using the right-side boxes to locate and select the virtual interface that represents the second endpoint in the logical connection, and click Add.

A *Links_with* association is added between the virtual link models, and the logical connection is displayed in the Logical Connection Table.

6. Repeat the preceding steps to create additional logical connections as needed, and click Close.

Create Logical Connections to Unmanaged Models

It is possible for a CA Spectrum user to be responsible for a circuit but not have SNMP contact with the device on one side. If this is the case, you can still create a logical connection that includes the unmanaged link model and manage the circuit from the other endpoint.

When you create a connection to an unmanaged link model, ATM Circuit Manager creates a model of type *UnmanAtmLink* and associates it with the *ATM_Network* or *ATM_Cloud* model using a *Contains* relation. As with all logical connections, a *Links_with* association between the managed and unmanaged virtual link models is created.

To create a logical connection to an unmanaged link model

1. Use the Navigation panel or the Topology tab to locate and select the *ATM_Cloud* or *ATM_Network* model that contains or is connected to the relevant device and interface models.
2. Click the Information tab, expand the Logical Connection Table, and click Add.

The Logical Connection Manager dialog opens.

3. Under Physical Ports on the left side of the dialog, select the physical port that contains the managed virtual link.
4. Under VCL Interface on the left side of the dialog, select the managed virtual link.

This virtual link will be the single point of management for the connection.

5. Under Physical Ports on the right side of the dialog, select a physical port on the unmanaged device.
6. Under VCL Interface on the right side of the dialog, select Unmanaged Link, and click Add.
7. Enter the following information about the unmanaged endpoint:

Name

The name of the virtual link model. For convenience, the name of the associated ATM_Network container model is used as the default name, so you can easily use it as a prefix for the name you specify.

Component OID

The component OID of the unmanaged endpoint (Port_ID.VPL.VCL).

Network Address

The network address of the unmanaged interface (if there is one assigned).

Circuit Name

The name of the circuit. This can be any name that has meaning, such as "London to Paris link."

Circuit ID

The ID of the circuit. This can be any ID that has meaning, such as "Leased Circuit 119."

8. Click OK.

The unmanaged link model is created, and the logical connection between it and the managed link model is also created.

Logical Connections Link in ATM and Frame Relay Models

If you have a mixture of ATM and Frame Relay interfaces on either side of a leased service provider's network, you can create logical connections between their virtual interfaces (VPLs, VPTs, VCLs, and DLCIs) using *Links_with* associations. The procedure for modeling these types of connections is the same as that for ATM-to-ATM logical connections with two exceptions:

- When following the procedure outlined in [Connect Physical Interfaces to Service Provider's Network](#) (see page 17), the physical interface selected in Step 1 will be a Frame Relay interface, such as a serial port.
- When following the procedure outlined in [Creating Logical Connections Manually](#) (see page 23), the virtual interface selected as an endpoint in Step 3 or Step 4 will be a DLCI virtual interface.

It is also possible to use a file to import a list of ATM-to-Frame Relay connections. To do this, you can use the import process described in [Importing Logical Connections](#) (see page 26), but you must access the Logical Connection Import subview that is available on the Information tab of the *VNM model*, not the Logical Connection Table subview that is available on the *ATM_Network* or *ATM_Cloud* model.

Note: For more information about Frame Relay, see the *Standards-Based Protocol Reference Guide*.

Import Logical Connections

You can create logical connections between virtual link models by importing a comma-delimited, ASCII file (text file or XML file) that defines the connections. You can define connections that include two ATM models or an ATM model and a Frame Relay model.

The file in which you define the logical connections must be a comma-delimited, ASCII file (text file or XML file). Use the following syntax to define a connection:

```
<device_IP_1>,<subinterface_OID_1>,<device_IP_2>,<subinterface_OID_2>,  
<circuit_name>,<circuit_ID>,<Pipe>
```

The parameters are as follows:

device_IP_1

Specifies the IP address of the first device in the connection.

subinterface_OID_1

Specifies the component OID of the first virtual interface in the connection.

device_IP_2

Specifies the IP address of the second device in the connection.

subinterface_OID_2

Specifies the component OID of the second virtual interface in the connection.

circuit_name

(Optional) Specifies the name of the circuit. This can be any name that has meaning.

circuit_ID

(Optional) Specifies the ID of the circuit. This can be any ID that has meaning.

pipe

(Optional) Specifies `CREATE_PIPE` to create a live pipe to graphically represent the connection. Otherwise, specify `NO_CREATE_PIPE`.

To import the logical connections defined in a file

1. In OneClick, use the Navigation window or the Topology view to select one of the following:
 - The ATM_Network that contains or has connections to the physical interfaces of the virtual link models for which you want to define connections
 - The ATM_Cloud that has connections to the physical interfaces of the virtual link models for which you want to define connections
2. In the Component Detail window, click the Information tab and expand Logical Connection Table.



3. Click  (Imports a file describing links between virtual interfaces).
4. In the Open dialog, navigate to the file that contains the connection definitions, select the file, and click Open.

The connection definitions are imported, and the logical connections are created. If the import process fails, you are notified in the Import Results dialog that describes the results of the operation.

5. In the Import Results dialog, click OK.

Note: You can find additional information about the import operation (and previous ones) on the Information tab under the Modeling Gateway subview for the VNM model. This view displays the name of the file that was imported, the location of the log file that was created for the operation, and other information.

Create Pipes Between Virtual Link Models

In some cases, you might want to create pipes (resolved connections) to represent important logical connections between virtual link models. This allows you to monitor the status of a circuit based on the pipe's color in the Topology view.

Note: For an introduction to pipes, see the *Modeling and Managing Your IT Infrastructure Administrator Guide*.

To create a pipe between virtual link models

1. Use the Navigation window or the Topology view to locate the device that contains one of the virtual link models, and select the device.

Information about the device is displayed in the Component Detail window.
2. In the Component Detail window, click the Interfaces tab.

The physical and virtual interfaces for the device are displayed on the tab.

3. Expand the physical interfaces to view the associated link models. You can right-click the interface to get the Expand All or Collapse All option for your IP address.
4. Select one of the virtual link models you want to connect with a pipe, right-click, and click Start Connection.
5. Select the other virtual link model to connect with the pipe, right-click, and click Connect With *<name of virtual link model>*, where *<name of virtual link model>* is the name of the interface model you selected in the previous step.

Note: You can also create pipes when you import a set of logical connections.

More information:

[Import Logical Connections](#) (see page 26)

Chapter 3: Monitoring and Managing the ATM Network

This section contains the following topics:

[About ATM Monitoring and Management](#) (see page 29)

[Monitor the Logical Connections Between Virtual Link Models](#) (see page 30)

[Monitor Virtual Link Models](#) (see page 31)

[View Virtual Link Models Performance](#) (see page 32)

[Set Traffic Thresholds for Virtual Link Models](#) (see page 34)

[Specify Service Information for Virtual Link Models](#) (see page 36)

[Specify Service Information for unmanATMLink model](#) (see page 37)

[Monitor Quality of Service \(QoS\) Information for VCLs](#) (see page 38)

[Graphical Representations of ATM Interface Connections](#) (see page 41)

About ATM Monitoring and Management

CA Spectrum lets you set up thresholds, monitor network performance, and diagnose several common network problems.

The management of PVPs and PVCs on ATM switches and ATM clients consists of:

- Monitoring the status of defined circuits
- Monitoring the status and performance of virtual link models
- Monitoring loads on models using thresholds and alarms
- Tracking service provider information
- Monitoring Quality of Service (QoS) information

Important! If you are monitoring Cisco devices with ATM Circuit Manager, and you are making use of CA Spectrum's Live Pipes feature or the PortPollStatus attribute to monitor connectivity, it is recommended that you use Cisco's Operation, Administration, and Maintenance (OAM) feature. Turning on this feature helps ensure that you can detect communication problems on a permanent virtual connection (PVC) when network connectivity is lost but the PVC remains up on the end devices. In this situation, if OAM is not configured, and a CiscoATMVclLnk goes down, an alarm is not generated. For more information, see the ATM technical tips on the Cisco web site.

Monitor the Logical Connections Between Virtual Link Models

As you monitor your ATM network, you need to view the logical connections between virtual link models, for example, so you can determine the status of a particular circuit represented by a connection.

To view the logical connections between virtual link models

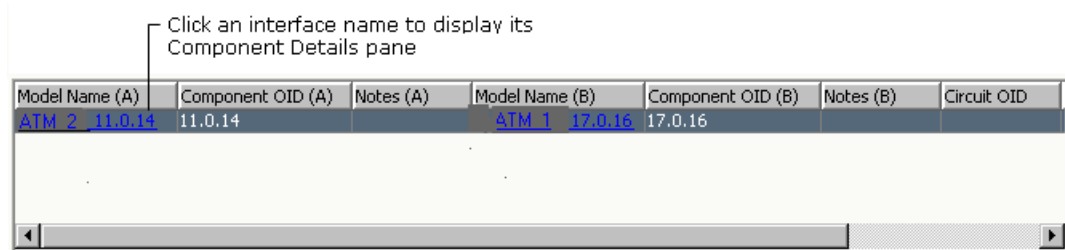

1. Use the Navigation panel or the Topology tab to locate and select the ATM_Cloud or ATM_Network model that the logical connection you want to view traverses or is a part of.
2. Click the Information tab and expand Logical Connection Table in the Component Detail panel.

The Logical Connection Table opens.



Model Name (A)	Component OID (A)	Notes (A)	Model Name (B)	Component OID (B)	Notes (B)	Circuit OID
ATM_2_11.0.14	11.0.14		ATM_1_17.0.16	17.0.16		

The connection table provides information about each connection; that is, the endpoint models and the logical connections they collectively represent. You can view a circuit's status by moving the scroll bar to the right.

3. To export the list of connections to a CSV, TXT, or HTML file, click  (Export).
4. To delete one or more connections, select them in the table and click  (Delete).
5. To display additional information in the Logical Connection Table, right-click the table heading, select the desired columns in the Table Preferences dialog, and click OK.

Monitor Virtual Link Models

As you monitor your ATM network, you need to view a device's virtual link models, for example, to determine their condition or status.

To view the virtual link models on an ATM device

1. Use the Navigation panel or the Topology tab to locate and select the device.
Information about the device is displayed in the Component Detail panel.
2. Click the Interfaces tab in the Component Detail panel.
The physical and virtual interfaces for the device are displayed on the tab.
3. Expand the physical interfaces to view its associated virtual link models. You can right-click the interface to get the Expand All or Collapse All option for your IP address.

The interface table identifies the condition, status, and general type of the interface (for example, VPL or VCL), among other information. If the interface is used in a logical connection, the device and port at the other end of the connection are displayed, respectively, in the Device Connected and Port Connected fields.

Note: You can set the interface IP address as the primary IP address for CA Spectrum management. To do this, right-click the interface, select Configure Primary Address for Device, and select Use Interface IP as Primary Address.

Note: To display additional information in the interface table, right-click the table heading, select the desired columns in the Table Preferences dialog, and click OK.

View Virtual Link Models Performance

You can use the Performance view of a virtual link model to access the following:

- The percentage of the virtual link's utilization for input and output.
- The throughput for input and output using the virtual link.

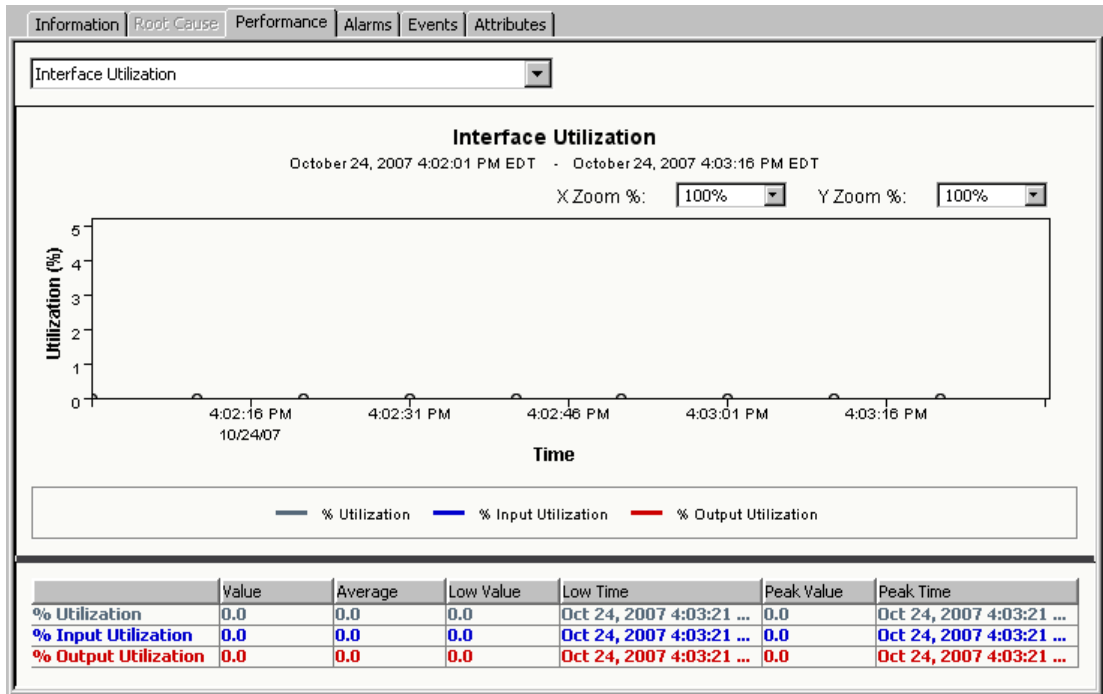

The current values are the last known values when the associated ATM device was polled. The other values are the average, low, and peak values since the Performance tab was opened.

The interface utilization calculations use the following statistical fields that indicate load:

- For input utilization, the value of the *rcvLoad* attribute
- For output utilization, the value of the *xmtLoad* attribute

The formulae for these attributes are as follows:

$$\text{rcvLoad} = \text{rcvCellsPerSecond} * 100 / \text{rcvBandwidth}$$

$$\text{xmtLoad} = \text{xmtCellsPerSecond} * 100 / \text{xmtBandwidth}$$

The *rcvBandwidth* and *xmtBandwidth* attributes are defined by either the Peak Cell Rate (PCR) or Sustainable Cell Rate (SCR) depending on the Quality of Service (QoS) type. For Variable Bit Rate (VBR) circuits, the bandwidth is defined as the SCR. For all other types of service, the bandwidth is defined as the PCR. This means that the load can exceed 100% for VBR circuits.

To always use the Peak Cell Rate (PCR) in bandwidth calculations—even for Variable Bit Rate (VBR) circuits—enable the corresponding setting in the VCL QoS Information view.

The *rcvCellsPerSecond* attribute is calculated by reading the attribute pointed to by *rcvCells_Attr* and the *upTime* attribute over a particular interval, and then subtracting the first values from the second values. This yields a delta of received cells and a delta of elapsed microseconds. By dividing the delta of cells by the delta of microseconds, and then multiplying by 100, the *rcvCellsPerSecond* value is determined.

You can log the values of the *rcvLoad* and *xmtLoad* attributes for historical reports.

Note: To use this Performance view, the ATM device must support the ATM2 MIB or one of the supported proprietary MIB extensions. Performance information is not available without the cell counters inherent in this MIB.

To view the virtual link model performance

1. Use the Navigation panel or the Topology tab to locate and select the device that has the virtual link model.

Information about the device is displayed in the Component Detail panel.

2. Click the Interfaces tab in the Component Detail panel.

The physical and virtual interfaces for the device are displayed on the tab.

3. Expand the physical interfaces to view the associated link models.

Note: You can right-click to get the expand all and collapse all option for your IP address.

4. Select the link model for which you want to view performance information, and click  (View the Component Detail for the selected model).

5. Click the Performance tab in the Component Detail panel.

The performance information for the selected virtual link model is displayed.

More information:

[Monitor Quality of Service \(QoS\) Information for VCLs](#) (see page 38)

Set Traffic Thresholds for Virtual Link Models

You can establish the levels of activity for virtual link models that will generate alarms. You do this by setting high and low thresholds for the following attributes:

Receive Load

The average number of bits received by the virtual link model since the last poll.

Transmit Load

The average number of bits transmitted by the virtual link model since the last poll.

Each high and low threshold has a "set" value and a "reset" value. For the high thresholds, the "set" value is the value that, if exceeded, generates an alarm for the attribute. The "reset" value is the value that, if gone below, automatically clears the alarm for the attribute. The "set" and "reset" values for the low thresholds work in the converse manner. The following illustration further describes the behavior.

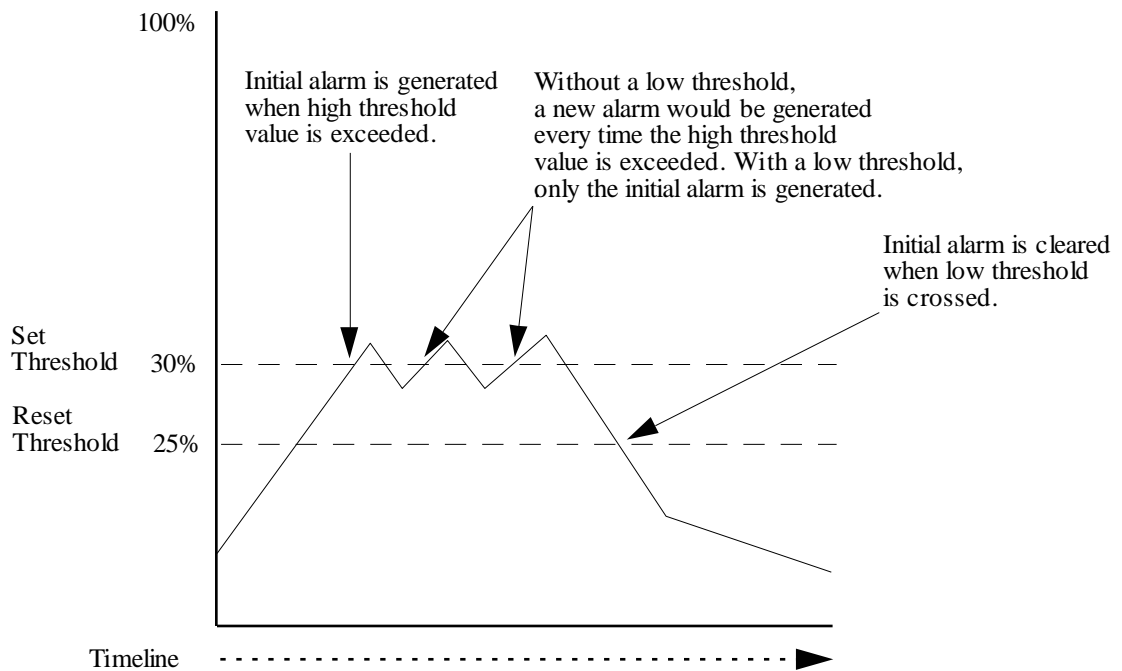

By default, the high thresholds are set to 90% and reset at 80%, and the low thresholds are set to 0 and reset at 0. In other words, the low thresholds are disabled. The threshold values are recalculated at every poll cycle and represent the average number per poll.

Important! Do not set the “reset” field to “0.” If the “reset” field is set to “0” and the “set” field is crossed, the subsequent alarm is never cleared automatically. If the alarm is cleared manually by the user, the CA Spectrum threshold intelligence is not reset, and the alarm for that model is not generated again. To reset the threshold intelligence, the SpectroSERVER must be restarted.

Note: To use this Threshold view, the ATM device must support the ATM2 MIB or one of the supported proprietary MIB extensions. Thresholds cannot be set for a circuit without the cell counters inherent in this MIB.

To set traffic thresholds for a virtual link model

1. Select the device that has the virtual link model you want to configure from the Navigation panel or the Topology tab.

Information about the device is displayed in the Component Detail panel.

2. Click the Interfaces tab in the Component Detail panel.

The physical and virtual interfaces for the device are displayed on the tab.

3. Expand the physical interfaces to view the associated link models.

Note: You can right-click the interface to get the Expand All or Collapse All option for your IP address.

4. Select the VPL or VCL model that you want to configure, and click  (View the Component Detail for the selected model).

5. Click the Information tab and expand VCL Threshold Information in the Component Detail panel.

6. Specify a value for any of the thresholds by clicking set, entering the value, and pressing Enter.

Specify Service Information for Virtual Link Models

For reference purposes, you can add information about the service provider for individual virtual link models.

To specify service information for a virtual link model

1. Use the Navigation panel or the Topology tab to locate and select the device that has the virtual link model you want to configure.

Information about the device is displayed in the Component Detail panel.

2. Click the Interfaces tab.

The physical and virtual interfaces for the device are displayed on the tab.

3. Expand the physical interfaces to view the associated link models.

Note: You can right-click the interface to get the Expand All or Collapse All option for your IP address.

4. Select the link model that you want to configure, and click  (View the Component Detail for the selected model).

5. Click the Information tab and expand VPL/VCL Service Information in the Component Detail panel.

6. Enter the service information by clicking 'set,' entering the text, and pressing Enter.

You can enter the following information:

Provider

Specifies the name of the service provider associated with the ATM network.

Note: ATM customers who use multiple carriers can use this field to indicate the carriers that provide service for specific circuits.

Customer

Users who are service providers and manage other companies' ATM networks can use this field to indicate the customer.

Primary Contact

Specifies the name, phone number, and email address of the person to contact if there is a problem with the circuit.

Secondary Contact

Specifies the name, phone number, and email address of a secondary person to contact if there is a problem with the circuit.

Service Notes

Miscellaneous information about the circuit, such as the circuit ID or the monthly cost.

Specify Service Information for unmanATMLink model

For reference purposes, you can add information about the service provider for unmanaged virtual link models.

To specify service information for an unmanATMLink model

1. Use the Navigation panel or the Topology tab to locate and select the ATM_Cloud or ATM_Network model where the unmanATMLink in question is defined as an endpoint of a logical connection.
2. Click the Information tab and expand Logical Connection Table in the Component Detail panel.
The Logical Connection Table opens.
3. Locate the relevant row in the table and click the name of the unmanATMLink to launch the Component Detail for the model.
4. Click the Information tab and expand VPL/VCL Service Information in the Component Detail panel.
5. Enter the service information by clicking 'set,' entering the text, and pressing Enter.

You can enter the following information:

Provider

Specifies the name of the service provider associated with the ATM network.

Note: ATM customers who use multiple carriers can use this field to indicate the carriers that provide service for specific circuits.

Customer

Users who are service providers and manage other companies' ATM networks can use this field to indicate the customer.

Primary Contact

Specifies the name, phone number, and email address of the person to contact if there is a problem with the circuit.

Secondary Contact

Specifies the name, phone number, and email address of a secondary person to contact if there is a problem with the circuit.

Service Notes

Miscellaneous information about the circuit, such as the circuit ID or the monthly cost.

Monitor Quality of Service (QoS) Information for VCLs

If you have configured your network for Quality of Service (QoS), you can use ATM Circuit Manager to view the following QoS information for VCL link models:

- The QoS class of the connection.
- Performance information for the connection, for example, the peak cell rate when receiving and transmitting data.
- The bandwidth used to receive and transmit data on the connection, as well as the parameters used to calculate the bandwidth.

Note: For information on how to configure, discover, and manage the QoS elements of your network using CA Spectrum QoS Manager, see the *QoS Manager User Guide*.

To monitor QoS information for a VCL

1. Use the Navigation panel or the Topology tab to locate and select the device that has the VCL model that you want to examine.

Information about the device is displayed in the Component Detail panel.

2. Click the Interfaces tab.

Note: You can right-click the interface to get the Expand All or Collapse All option for your IP address.

The physical and virtual interfaces for the device are displayed on the tab.

3. Expand the physical interfaces to view the associated link models.

4. Select the VCL model that you want to examine, and click  (View the Component Detail for the selected model).

5. Click the Information tab and expand VCL QoS Information.
The QoS information for the selected VCL model is displayed.
6. (Optional) Click set in the Use Peak Cell Rate (PCR) for bandwidth calculation field and select Enabled to specify that the peak cell rate (PCR) of the connection is always used in bandwidth calculations.

Note: Alternatively, you can disable this setting if you want the parameters used in bandwidth calculations to be determined based on the QoS class.

More information:

[Receive and Transmit QoS Parameters](#) (see page 39)

[Bandwidth Parameters](#) (see page 40)

Receive and Transmit QoS Parameters

The VCL QoS Information view displays information on the following receive and transmit parameters:

QoS Class

The QoS class used for the connection.

QoS Peak Cell Rate

The maximum number of cells that the connection can receive or transmit per second on the network.

QoS Sustained Cell Rate

The average number of cells that the connection can receive or transmit per second on the network.

QoS Max Burst Size

The maximum allowable burst size (in cells) that can be transmitted contiguously at the peak cell rate over this link.

QoS Tagging

If On (enabled), the Cell Loss Priority (CLP) bit of cells is marked (tagged) because the cells do not conform to the subscribed QoS contract. Tagged cells have a lower priority than other cells, and they are the first cells to be dropped by the network when traffic is congested.

QoS CLPO Peak Cell Rate

The maximum number of cells with the CLP bit set that the connection can receive or transmit per second on the network.

QoS CLPO Sustained Cell Rate

The average number of cells with the CLP bit set that the connection can receive or transmit per second on the network.

QoS CLPO Max Burst Size:

The maximum allowable burst size (in cells) that can be transmitted contiguously with the CLP bit set at the CLP peak cell rate.

Bandwidth Parameters

The VCL QoS Information view displays the maximum bandwidth that can be used by the connection to receive and transmit data.

Receive Bandwidth Calculations

The *Receive Bandwidth value* is the maximum number of bits per second that can be received by the connection.

By default, if the connection's QoS class is Variable Bit Rate, the Receive Bandwidth value is calculated using the Receive - QoS Sustained Cell Rate as follows:

Receive Bandwidth (bits per second) = (Sustained Cell Rate (cells per second) * 53 (bytes per cell)) * 8 (bits per byte)

If the connection's QoS class is any other class, the Receive Bandwidth value is calculated using the Receive - QoS Peak Cell Rate as follows:

Receive Bandwidth (bits per second) = (Peak Cell Rate (cells per second) * 53 (bytes per cell)) * 8 (bits per byte)

Transmit Bandwidth Calculations

Transmit Bandwidth Calculations

The *Transmit Bandwidth value* is the maximum number of bits per second that can be transmitted by the connection.

By default, if the connection's QoS class is Variable Bit Rate, the Transmit Bandwidth value is calculated using the Transmit - QoS Sustained Cell Rate as follows:

Transmit Bandwidth (bits per second) = (Sustained Cell Rate (cells per second) * 53 (bytes per cell)) * 8 (bits per byte)

If the connection's QoS class is any other class, the Transmit Bandwidth value is calculated using the Transmit - QoS Peak Cell Rate as follows:

Transmit Bandwidth (bits per second) = (Peak Cell Rate (cells per second) * 53 (bytes per cell)) * 8 (bits per byte)

Using the Peak Cell Rate (PCR) in Bandwidth Calculation

The QoS Information view includes a Use Peak Cell Rate (PCR) for bandwidth calculations setting that you can use to specify how bandwidth calculations are performed.

By default, the setting is disabled, which means that the values for Receive Bandwidth and Transmit Bandwidth are calculated as described previously in this topic. However, if you enable this setting, the bandwidth values are calculated as follows:

- If the receive and transmit values for QoS Peak Cell Rate are specified, the Peak Cell Rate is always used to calculate the bandwidth.
- If the receive and transmit values for QoS Peak Cell Rate and QoS Sustained Cell Rate are not specified, the bandwidth is set to the value of If Speed.

Graphical Representations of ATM Interface Connections

In OneClick, in the Topology tab of your ATM network, you can click any pipe (connection) to view a graphical, port-to-port representation of the connection in the Component Detail panel.



This is helpful when you need to quickly identify the physical interfaces involved in the connection represented by a pipe.

If you have created logical connections between virtual link models and created pipes during the import process, or if you have manually created resolved connections between virtual link models (which automatically creates pipes), this view can also show the logical connections represented by a pipe.



Note: In this view, you can click any interface model to display the Interfaces tab for the associated device in the Component Detail panel.

More information:

[Create Pipes Between Virtual Link Models](#) (see page 27)

Chapter 4: Managing Faults

This section contains the following topics:

[Fault Management Overview](#) (see page 43)

[Fault Management Using Link Status](#) (see page 43)

[Manage Faults Using Threshold Alarms](#) (see page 44)

[Fault Management on Cisco Routers](#) (see page 45)

[Fault Isolation Across Switched Fabric](#) (see page 47)

Fault Management Overview

Once you have created an accurate model of your ATM network, ATM Circuit Manager can detect faults on the ATM circuits, isolate the root cause of an outage or service degradation, and alert the user to a problem using an alarm.

CA Spectrum uses three different methods to monitor virtual interface models and manage faults across the switched fabric in an ATM environment:

- For devices that support the standard ATM MIB, the status of each virtual link model is monitored using the following MIB objects:
 - atmVclAdminStatus and atmVclOperStatus (for VCL models)
 - atmVplAdminStatus and atmVplOperStatus (for VPL models)

If a model is determined to be inactive, an alarm is generated.

- You can set high and low traffic thresholds for VPLs and VCLs so that an alarm is generated if the load on a particular circuit falls above or below what you expect.
- If one endpoint of an ATM circuit is a Cisco router, by default CA Spectrum periodically initiates a "remote ping" from the router to the IP address on the other side of the circuit. If the ping fails, an alarm is generated.

Fault Management Using Link Status

For devices that support the standard ATM MIB, CA Spectrum reads the Internal_Link_Status attribute of each virtual link model every polling interval. This attribute is calculated based on the values of the following administrative and operational status objects:

- atmVclAdminStatus and atmVclOperStatus (for VCL models)
- atmVplAdminStatus and atmVplOperStatus (for VPL models)

If the value of the `Internal_Link_Status` attribute is not active, it is assumed that an error condition has occurred, and an attempt is made to isolate the problem to the model itself or to its parent model. This is done by reading the `Internal_Link_Status` attribute of the parent model, which could be a trunk or a physical interface.

If the parent model is active, a red alarm is asserted on the inactive model to indicate that the problem has been isolated. If the parent model is *not* active, a gray alarm is asserted on the inactive model to indicate a suppressed condition, and the fault isolation process continues until the source of the problem is identified.

Manage Faults Using Threshold Alarms

ATM virtual link models have an ATM Threshold view that allows you to specify the levels of activity that generate alarms. This can be useful if a specific amount of traffic on an ATM model is the norm, and you want CA Spectrum to generate an alarm if less or more traffic occurs (because this indicates a problem exists).

For this functionality to be active, you need to set the virtual link model's `PollingStatus` attribute to Yes (for TRUE). This attribute is set to No by default to limit management traffic over ATM links.

To set the `PollingStatus` attribute for a virtual link model

1. Use the Navigation panel or the Topology tab to locate and select the device that has the virtual link model you want to configure.
Information about the device is displayed in the Component Detail panel.
2. Click the Interfaces tab in the Component Detail panel.
The physical and virtual interfaces for the device are displayed on the tab.
3. Expand the physical interfaces to view the associated link models.
4. Select the virtual link model that you want to configure, and click  (View the Component Detail for the selected model).
5. Click the Attributes tab in the Component Detail window.
6. Set the `PollingStatus` attribute to Yes.

Note: For information on using the Attributes tab to change attribute values, see the *Modeling and Managing Your IT Infrastructure Administrator Guide*.

More information:

[View Virtual Link Models Performance](#) (see page 32)

Fault Management on Cisco Routers

If you have Cisco routers in your ATM network, ATM Circuit Manager uses the CiscoPingApp application model to initiate remote pings to determine the status of ATM PVCs. An inference handler examines the ATM connections for a particular router, and then it instructs the router to ping the IP addresses of the routers on the other side of the ATM PVC. If a ping fails, an event with an event code of 0x02dc0001 is sent to the ATM virtual link model that represents this router's side of the ATM PVC. This generates a red alarm on the model; the alarm includes the probable cause information shown below.

REMOTE PING FAILURE MAY INDICATE A PVC FAILURE

SYMPTOMS:

The SpectroSERVER initiated a remote ping from one router to another over an ATM PVC. Not all ICMP echos were received back by this router.

PROBABLE CAUSES:

The PVC connecting this router to the IP address that was pinged may be down.

RECOMMENDED ACTIONS:

- 1) Check the Event tab to see what IP address was pinged.
- 2) Verify that all PVCs on this device are operating normally.

If desired, you can change the severity of this alarm or prevent it from being generated using the Event Configuration application.

Note: For information on using the Event Configuration application, see the *Event Configuration User Guide*.

If the ATM network has redundant paths set up or the OSPF (Open Shortest Path First) routing protocol is being used, remote pinging may return information that is not completely useful in determining the health of the network and, therefore, will use bandwidth unnecessarily.

Also note that the ATM Circuit Manager only initiates 5 remote pings per router at a time until all of the remote pings have been tried. This prevents the possibility of the router becoming overloaded.

Configure CiscoPingApp Application Model

You can configure the following attributes of a CiscoPingApp application model:

CommunityNameForSNMPSets

The community name that is used when performing SNMP sets. By default, this value is inherited from the CommunityNameForSNMPSets attribute on the device model.

In order for CA Spectrum to initiate remote pings from a Cisco router, CA Spectrum must perform SNMP sets. To allow sets to be performed, the CiscoPingApp application model must have a community name that allows CA Spectrum to write to the device's MIB (in other words, a community name with read and write capabilities).

If the value of this attribute for the application model differs from the value for the device model, the value for the application model takes precedence.

If this attribute is unset on both the device model and the application model, CA Spectrum uses the value of the Community_Name attribute. Thus, if the value of the Community_Name attribute is a name with read and write capabilities, and the CommunityNameForSnmpSets attribute is unset, remote ping works properly.

Note: For more information on these attributes, see the *Concepts Guide*.

EnableRemotePings

Enables and disables remote pinging. If set to No (for FALSE), remote pinging from the router is disabled. The default value is Yes (for TRUE).

NumberOfPingPackets

The number of ping packets the router will send to the remote IP address.

Default: 3

PingFailuresAllowed

The number of ping request failures allowed before an alarm is generated.

Default: 2

PingInterval

The interval in seconds between remote ping requests.

Default: 300

PingPacketSize

The size in bytes of the ping packet that the router will send to the remote IP address.

Default: 128

Note: NumberOfPingPackets, PingFailuresAllowed, and PingInterval, collectively, are used to increase the frequency of remote pinging and the speed of any network fault detection. For example, if PingInterval were lowered to 60, NumberOfPingPackets remained set at 3, and PingFailuresAllowed were decreased to 0, the ping requests would be initiated more frequently, and no failure of any of these requests would be allowed. This would result in the ATM network being more closely monitored for remote link problems, and, if problems were discovered, alarms would be generated more quickly.

To configure one or more CiscoPingApp application models

1. Use the Locator tab to find all models of model type CiscoPingApp.

The CiscoPingApp models are listed on the Results tab in the Contents panel.

2. Do one of the following:

- To configure a single model, select it, and click the Attributes tab in the Component Detail panel. Then use the Attributes tab to configure the CiscoPingApp model attributes.
- To configure multiple models, right-click them all and click Tools, Utilities, Attribute Editor. Add the CiscoPingApp model attributes that you want to configure to the User Defined folder in the Attributes tree, and then use the Attribute Editor to modify the attributes.

Note: For more information about using the Attributes tab and the Attribute Editor to change attribute values, see the *Modeling and Managing Your IT Infrastructure Administrator Guide*.

Fault Isolation Across Switched Fabric

ATM Circuit Manager allows CA Spectrum to extend its fault isolation capability through the switched fabric of an ATM network. The switched fabric can be part of your own network infrastructure, or it can be part of a leased infrastructure on a service provider's network.

If you are managing your own switched fabric, there will be one or more ATM_Network models in your network topology. The ATM switches that make up the switched fabric are collected inside the ATM_Network model, and the ATM clients (routers, bridges, and so on) will be adjacent to the ATM_Network model. In this scenario, the managed circuits go from one client-through the switched fabric in the ATM_Network model-to another client. The channels and trunks within the switched fabric are not managed unless this functionality has been specified.

If you are leasing channels or trunks through a service provider's network, you will use an ATM_Cloud model in the CA Spectrum topology to represent the service provider's switched fabric. In this scenario, the managed circuits go from one client-through the switched fabric in the ATM_Cloud model-to another client. The channels and trunks within the switched fabric are not managed.

Connections between virtual link models are used to determine an ATM device's neighbors. The neighbors of a device are queried during fault isolation to determine where the source of the problem is located.

As an example, the following illustration shows four routers (R1, R2, R3, and R4) connected across a switched fabric. The logical connections between the routers are indicated by dotted lines, and the physical connections are indicated by solid lines. If the SpectroSERVER has a problem reaching R2, it will check the status of R2's neighbors to isolate the fault. Since the ATM Circuit Manager uses logical connectivity to determine device neighbors, both R1 and R3 will be considered neighbors of R2.

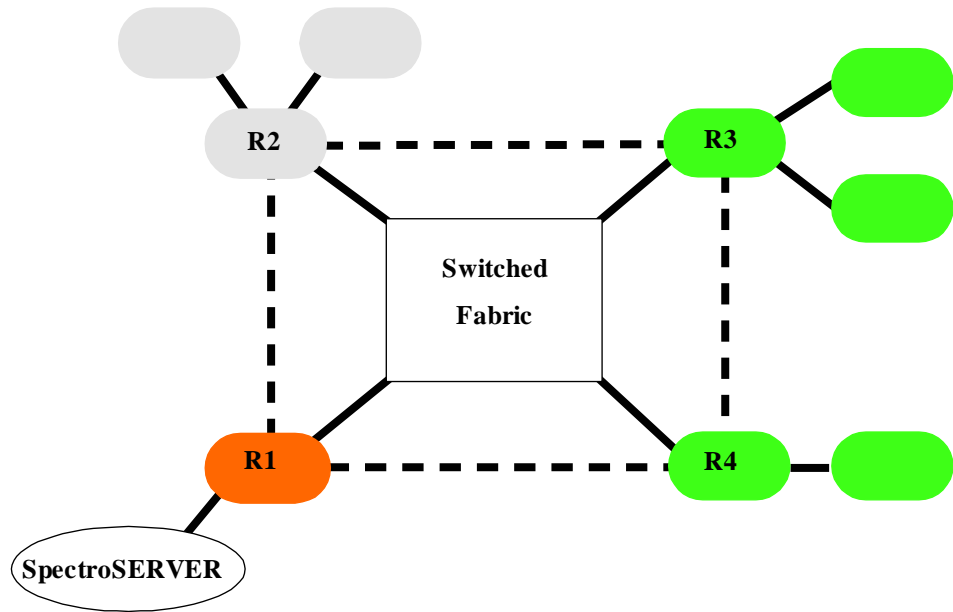

If, for example, R3 responds that it is available, but R1 does not respond, CA Spectrum creates a red alarm on R1 and changes R2 and the models that depend on its connectivity to gray to indicate a suppressed state.

If ATM Circuit Manager did not have the capability to use logical connectivity to determine device neighbors, it would not be able to isolate the fault to R1. Instead, R2 and its connected devices would change to gray to indicate a suppressed state, and an unresolved red alarm would be created on the generic Fault Management model to indicate the communication problem. The red alarm would be viewable in the Alarms tab in OneClick, but it would not appear linked to any device model in the Topology tab.

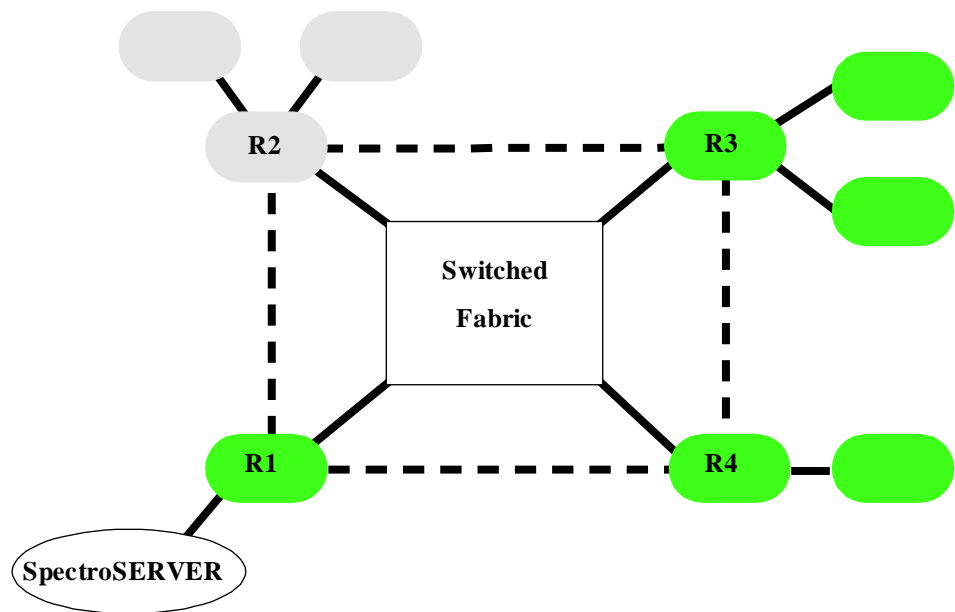

More information:

[Specify Virtual Links to Model for a Device](#) (see page 20)

Glossary

channel

A *channel* is a data transmission link between two or more points.

path

A *path* is a large communications pipe that pre-allocates bandwidth and allows for greater flexibility in establishing PVCs. A defined amount of bandwidth is leased from a service provider, and as many PVCs as necessary within the limits of that bandwidth can be established.

permanent virtual circuit (PVC)

A *permanent virtual circuit (PVC)* is a logical connection that is manually created by a network administrator. This connection is maintained at all times even if it is not always in use. PVCs can exist without being a part of a PVP.

permanent virtual path (PVP)

A *permanent virtual path (PVP)* is a logical communications path that has a defined amount of leased bandwidth. The path is maintained at all times even if it is not always in use.

switched virtual circuit (SVC)

A *switched virtual circuit (SVC)* is a temporary connection that is established and maintained only for the duration of a data transfer session.

virtual channel identifier (VCI)

The *virtual channel identifier (VCI)* is a field of a cell header that contains the address of the virtual channel.

virtual channel link (VCL)

A *virtual channel link (VCL)* is a unidirectional method of transport for ATM cells that begins at the point where a VCI value is assigned and ends at the point where the VCI value is translated or removed.

virtual path identifier (VPI)

The *virtual path identifier (VPI)* is a field of a cell header that contains the address of the virtual path.

virtual path trunk (VPT)

A *virtual path trunk (VPT)* is a unidirectional method of transport for ATM cells that begins at the point where a VPI value is assigned and ends at the point where the VPI value is translated or removed. A VPT is made up of a group of VCLs with the same VPI value.

Index

A

alarms • 43, 44
ATM and Frame Relay • 11
ATM cell • 7
ATM interface • 17
ATM interface model • 8
ATM Link • 34
ATM MIBs • 18
ATM_Cloud • 10, 11
ATM_Cloud model • 11, 17
ATM_Network model • 10, 11

B

bandwidth • 32
Bandwidth Parameters • 40

C

Cisco routers • 45
CiscoPingApp • 45
CLP bit • 39
contacting technical support • iii
customer support, contacting • iii

F

Frame Relay interface • 25

H

high threshold values • 34

I

ifIndex • 18
index • 18
Internal_Link_Status • 43

L

load • 32
low threshold values • 34

M

managed virtual circuit • 22

O

Open Shortest Path First • 45

OSPF • 45

P

PCR • 32
Peak Cell Rate • 32
PVC • 45
PVCs • 11
PVPs • 11

Q

QoS • 32
QoS (Quality of Service) Information view • 38
QoS Cell Delay VT • 40
QoS Class • 39
QoS CLPO Max Burst Size • 39
QoS Peak Cell Rate • 39
Quality of Service • 32

R

rcvBandwidth • 32
rcvCells_Attr • 32
rcvCellsPerSecond • 32
rcvLoad • 32
Receive QoS • 39
red alarm • 45
remote pings • 45

S

SCR • 32
support, contacting • iii
Sustainable Cell Rate • 32

T

technical support, contacting • iii

U

Unmanaged Link option • 24
UnmanAtmLink model • 11, 24
upTime • 32

V

Variable Bit Rate • 32
VBR • 32
VCL • 11

VCL index • 18
VCLs • 18
Virtual Channel Identifier • 18
Virtual Channel Links • 18
virtual link models • 23
virtual links • 18
Virtual Path Identifier • 18
Virtual Path Trunks • 18
VPL • 11
VPL index • 18
VPLs • 18

X

xmtBandwidth • 32
xmtLoad • 32