

# CA PMA Chargeback™

## User Guide

Release 12.6.00



This documentation, which includes embedded help systems and electronically distributed materials, (hereinafter referred to as the "Documentation") is for your informational purposes only and is subject to change or withdrawal by CA at any time.

This Documentation may not be copied, transferred, reproduced, disclosed, modified or duplicated, in whole or in part, without the prior written consent of CA. This Documentation is confidential and proprietary information of CA and may not be disclosed by you or used for any purpose other than as may be permitted in (i) a separate agreement between you and CA governing your use of the CA software to which the Documentation relates; or (ii) a separate confidentiality agreement between you and CA.

Notwithstanding the foregoing, if you are a licensed user of the software product(s) addressed in the Documentation, you may print or otherwise make available a reasonable number of copies of the Documentation for internal use by you and your employees in connection with that software, provided that all CA copyright notices and legends are affixed to each reproduced copy.

The right to print or otherwise make available copies of the Documentation is limited to the period during which the applicable license for such software remains in full force and effect. Should the license terminate for any reason, it is your responsibility to certify in writing to CA that all copies and partial copies of the Documentation have been returned to CA or destroyed.

TO THE EXTENT PERMITTED BY APPLICABLE LAW, CA PROVIDES THIS DOCUMENTATION "AS IS" WITHOUT WARRANTY OF ANY KIND, INCLUDING WITHOUT LIMITATION, ANY IMPLIED WARRANTIES OF MERCHANTABILITY, FITNESS FOR A PARTICULAR PURPOSE, OR NONINFRINGEMENT. IN NO EVENT WILL CA BE LIABLE TO YOU OR ANY THIRD PARTY FOR ANY LOSS OR DAMAGE, DIRECT OR INDIRECT, FROM THE USE OF THIS DOCUMENTATION, INCLUDING WITHOUT LIMITATION, LOST PROFITS, LOST INVESTMENT, BUSINESS INTERRUPTION, GOODWILL, OR LOST DATA, EVEN IF CA IS EXPRESSLY ADVISED IN ADVANCE OF THE POSSIBILITY OF SUCH LOSS OR DAMAGE.

The use of any software product referenced in the Documentation is governed by the applicable license agreement and such license agreement is not modified in any way by the terms of this notice.

The manufacturer of this Documentation is CA.

Provided with "Restricted Rights." Use, duplication or disclosure by the United States Government is subject to the restrictions set forth in FAR Sections 12.212, 52.227-14, and 52.227-19(c)(1) - (2) and DFARS Section 252.227-7014(b)(3), as applicable, or their successors.

Copyright © 2011 CA. All rights reserved. All trademarks, trade names, service marks, and logos referenced herein belong to their respective companies.

# Contact CA Technologies

## Contact CA Support

For your convenience, CA Technologies provides one site where you can access the information you need for your Home Office, Small Business, and Enterprise CA Technologies products. At <http://ca.com/support>, you can access the following:

- Online and telephone contact information for technical assistance and customer services
- Information about user communities and forums
- Product and documentation downloads
- CA Support policies and guidelines
- Other helpful resources appropriate for your product

## Provide Feedback

If you have comments or questions about CA Technologies product documentation, you can send a message to [techpubs@ca.com](mailto:techpubs@ca.com).

If you would like to provide feedback about CA Technologies product documentation, complete our short customer survey, which is available on the CA Support website at <http://ca.com/docs>.



# Contents

---

<b>Chapter 1: CA PMA Chargeback Overview</b>	<b>13</b>
CA Common Services for z/OS and OS/390	13
Sharing Information with Other Products	14
Charging Options	14
Other Features	15
What is CA PMA Chargeback	16
CA PMA Chargeback Input Sources	17
CA PMA Chargeback Functional Overview	17
Online Functions	18
Batch Functions	19
CA PMA Chargeback Output	20
CA PMA Chargeback Terms & Related Concepts	20
Terms	20
Related Concepts	24
Version	24
The Commit Process	26
The Parameter Files	26
CA PMA Chargeback Rules & Cautions	29
How Information is Displayed on CA PMA Chargeback Panels	29
Specifying Search Strings	29
Naming Conventions	29
Specifying Numerics	30
Qualifier Conventions	30
Panels You Will See When Using CA PMA Chargeback	30
The CA PMA Chargeback Primary Panel	31
Action Bar Pull-Downs	35
Windowing	39
Standard Panels	42
Function Key Summary	54
CA PMA Chargeback Relational Characteristics	56
CA PMA Chargeback Tables	57
Definition Tables	58
Data Tables	60
Internal Tables	61

---

## **Chapter 2: CA PMA Chargeback & DataManager Interrelationships** **63**

Overview .....	63
Version Interrelationships .....	64
Commit Interrelationships .....	65
Rules .....	65

## **Chapter 3: Setting Up Your Accounting Structure** **67**

Overview .....	67
Accounting Structure Panel .....	69
Defining Your Accounting Sources .....	71
Accounting Sources Primary Panel .....	73
Accounting Sources List Panel .....	75
Expanded Sources List Panel .....	77
Accounting Sources Entry Panel .....	78
Example 1: Defining Accounting Sources Without a Lookup Table .....	81
Example 2: Defining Accounting Sources Using a Lookup Table .....	82
Creating a Lookup Table .....	83
Example 1: Defining Entities for a Division .....	86
Example 2: Defining Entities for a Department .....	87
Defining Accounting Periods .....	89

## **Chapter 4: Defining Charges** **91**

Overview .....	91
Defining Charge Elements .....	93
The Chargeback Algorithm .....	94
Calculation Logic .....	95
Extended Charging Example .....	96
Charge Elements Panels .....	98
Charge Elements Primary Panel .....	98
Charge Elements List Panel .....	100
Expanded Charge Elements List Panel .....	101
Charge Elements Entry Panel .....	102
Example 1: Creating a Simple Charge Algorithm .....	106
Example 2: Defining a Normalized Complex Charge Unit with a Conditional Rate .....	107
Charge Units Entry Panel .....	109
Examples: Defining a Complex Charge Unit .....	113
Example 1: Defining a Complex Unit without a Constant .....	114
Example 2: Defining a Complex Unit with a Constant .....	115
Qualified Rates Entry Panel .....	116
Examples: Defining Conditional Rates .....	120

---

Example 1: Defining Conditional Rates by Qualifier .....	121
Example 2: Defining Conditional Rates by Qualifier .....	122
Qualifier Entry Panel .....	123
Expanded Qualifier Entry Panel .....	126
Examples: Defining Qualifiers .....	127
Example 1: Qualifying an ORD by Start Time .....	128
Example 2: Qualifying an ORD by Day of Week & Start Time .....	130
Example 3: Defining a Qualifier Using Other Qualifiers .....	132
Example 4: Qualifying a Normalizer .....	133
Normalizer Entry Panel .....	134
Examples: Defining a Normalizer .....	138
Example: Normalizing a Complex Charge Unit .....	139
Other Examples .....	140
Defining Charge Units, Normalizers, & Qualifiers Directly .....	142
Charge Units Panels .....	143
Charge Units Primary Panel .....	144
Charge Units List Panel .....	146
Expanded Charge Units List Panel .....	147
Charge Units Entry Panel .....	148
Normalizer Panels .....	152
Normalizer Primary Panel .....	153
Normalizer List Panel .....	155
Expanded Normalizer List Panel .....	156
Normalizer Entry Panel .....	157
Qualifier Panels .....	160
Qualifiers Primary Panel .....	161
Qualifier List Panel .....	163
Qualifier Entry Panel .....	165
Defining Modifiers .....	169
Modifiers Primary Panel .....	170
Modifier List Panel .....	172
Expanded Modifier List Panel .....	173
Modifier Entry Panel .....	174
Examples .....	178
Example 1: Modifying Charges Using ORD & Element Criteria .....	182
Example 2: Modifying Charges by Structure .....	183
Example 3: Modifying Charges by Qualifier .....	184
Example 4: Using a Wildcard with Selection Criteria .....	185
Defining Split Resources .....	186
Split Charges Primary Panel .....	187
Split Charges List Panel .....	189
Split Charges Expanded List Panel .....	190

---

Split Charges Entry Panel .....	191
Example 1: Splitting a Resource Charge Between Two Accounting Levels .....	194
Example 2: Splitting a Resource Charge Among Four Accounting Levels .....	195
Shift Chop Definition .....	197
Example: Defining a Shift Chop .....	199

## **Chapter 5: Defining Adjustments** **201**

Overview .....	201
Cost Recovery Panels .....	203
Cost Recovery Primary Panel .....	204
Cost Recovery List Panel .....	206
Expanded Cost Recovery List Panel .....	207
Cost Recovery Entry Panel .....	208
Example 1: Cost Recovery From a Single Accounting Level .....	210
Example 2: Cost Recovery from All Accounting Levels using a Qualifier .....	211
Performing Overhead Distribution .....	212
Overhead Distribution Primary Panel .....	213
Overhead Distribution List Panel .....	215
Expanded Overhead Distribution List Panel .....	217
Overhead Distribution Entry Panel .....	218
Example 1: Distributing Overhead Globally Across Accounting Levels that Have a @SHIFT1 Qualification .....	221
Example 2: Distributing Overhead Among an Accounting Level .....	222

## **Chapter 6: Performing Query Functions** **223**

Charge Query Panels .....	225
Charge Query Primary Panel .....	227
Charge Query List Panel .....	229
Expanded Query List Panel .....	231
Charge Query Specifications Panel .....	232
Charge Query Specifications Processing Options .....	238
Charge Query Specifications Entry Field Options .....	247
Budget Query Specifications Panel .....	257
Budget Query Specifications Processing Options .....	262
Budget Query Specifications Entry Field Options .....	266
DB/CR Query Specifications Panel .....	268
DB/CR Query Specifications Processing Options .....	272
DB/CR Query Specifications Entry Field Options .....	276

---

## Chapter 7: Performing Data Functions

279

Budgets Panels	280
Budgets Primary Panel	281
Budget Browse Criteria Panel	283
Example 1: Specifying Budget Browse Criteria by ORD Type & Period	286
Example 2: Specifying Budget Browse Criteria by Qualifier	287
Budget List Panel	288
Expanded Budget List Panel	289
Example 1: Selecting a Browse List Entry By ORD Type for a Specific Period	290
Example 2: Selecting a Browse List Entry By Qualifier	291
Budget Entry Panel	292
Example 1: Defining a Budget by ORD Type for an Accounting Level	296
Example 2: Defining a Budget for an Accounting Level	297
Example 3: Updating a Budget	298
Example 4: Deleting a Budget Record	301
Debits/Credits Panels	304
Debits/Credits Primary Panel	305
DB/CR Browse Criteria Panel	307
Example 1: Specifying Debit/Credit Browse Criteria by ORD Type & Period	309
Example 2: Specifying DB/CR Browse Criteria by Qualifier	310
Debit/Credit List Panel	311
Debit/Credit Expanded List Panel	313
Example 1: Selecting a Browse List Entry By ORD Type	314
Example 2: Selecting a Browse List Entry By Qualifier	315
Debits/Credits Entry Panel	316
Example 1: Creating a Credit	321
Example 2: Creating a Debit	323
Example 3: Updating a Credit	325
Example 4: Updating a Debit (Changing a Debit to a Credit)	328
Example 5: Deleting a Debit or a Credit Entry	331

## Chapter 8: Using Period Functions

335

Forecast Panels	336
Overall Forecast Results Panel	338
Example 1: Forecasting Using the COPY Algorithm	340
Example 2: Forecasting Using the Line Algorithm (Results)	341
Example 3: Forecasting Using the Smooth Algorithm (Results)	342
Forecast Elements List Panel	344
Forecast Element Panel	347
Forecast Qualifiers List Panel	349
Forecast Qualifier Panel	352

---

Example 1: Adjusting the Amount of the SHIFT1 Qualifier .....	354
Rate Determination Panels .....	355
Rate Determination (Elements) Entry Panel .....	356
Rate Determination (Qualifiers) Entry Panel .....	359
Example 1: Recovering Charges for Element CPU-CHARGE .....	362
Copy MOD -> TAB .....	364

## **Chapter 9: Setting CA PMA Chargeback Options** **367**

Overview .....	367
User Options Panel .....	369
The Are You Sure? Window .....	371
Versions .....	372
Examples .....	373

## **Chapter 10: Using Help** **377**

Requesting Help .....	377
The About Window .....	379
Help Panel Areas .....	380
Overview .....	380
Help Function Key Settings .....	381
Moving Through Help .....	382
Exiting Help .....	382
Help Panels .....	383
Panel Help .....	383
Field Help .....	384
The Table of Contents Panel .....	385
Topic Help Panel .....	386
Index Help Panels .....	387
The Help for Help Panel .....	388

## **Chapter 11: Batch Processing & Reporting** **389**

Overview .....	389
The Parameter Files .....	390
CAIKSPAR Parameter File .....	391
CAIKRPAR Parameter File .....	394
The Archive/Restore Program (CAKSARCH) .....	397
CAKSARES Procedure .....	398
The BACKUP Option .....	399
The RESTORE Option .....	403
The COMMIT Option .....	406

---

The COPY Option .....	412
CA PMA Chargeback Processing .....	416
CA PMA Chargeback Daily Processing .....	416
The User Exit for CAKRLOAD .....	422
Batch Forecasting (CAKRFCB) .....	427
Summary Processing (CAKRBREC) .....	435
Period Processing Programs .....	438
Reporting with CA Earl .....	444
The CAKSEARL Procedure .....	444
Reconciliation Reports .....	446
Generating CA PMA Chargeback Invoices .....	453
Generating the General Ledger Interface File .....	464
Using CAKRINST as a Utility Program .....	466
Setting Up Security Views on CCCTAB .....	467

## **Chapter 12: CA PMA Chargeback Security and Audit** **469**

Introduction .....	469
CA Top Secret Security .....	469
CA ACF2 Security .....	470
RACF Security .....	471
Implementing Security for the CA PMA Chargeback Query System .....	472

## **Appendix A: CA PMA Chargeback Tables** **473**

ACCSRTAB (Accounting Sources Table) .....	473
ACCSTTAB (Accounting Structure Table) .....	474
ACCTLOOK (Lookup Table) .....	474
BUDTAB (Budget Table) .....	475
CCCMOD (The 'Scratchpad' Table) .....	475
CCCTAB (Consolidated Calculated Charges Table) .....	476
CHOPTAB (Shift Chopper Definition Table) .....	477
DBCRTAB (Credit and Debit Table) .....	477
ELEMTAB (Charge Element Definition Table) .....	478
MODTAB (Charge Modifier Table) .....	479
NORMTAB (Unit Normalization Table) .....	479
OPTTAB (Option Settings Definition Table) .....	480
PERTAB (Period Definition Table) .....	480
QUALTAB (Algorithm Qualifier Definition Table) .....	481
QUERYTAB (Saved Query Definition Table) .....	482
RATETAB (Charge Algorithm Definition Table) .....	483
SPLITTAB (Split Resource Definition Table) .....	484
SUMTAB (Summary Function Definition Table) .....	484

---

UNITTAB (Charge Unit Definition Table) .....	485
<b>Appendix B: CA PMA Chargeback Panel Displays: Monochrome vs. Color</b>	<b>487</b>
<b>Glossary</b>	<b>489</b>
<b>Appendix C: Glossary</b>	<b>493</b>
<b>Index</b>	<b>505</b>

# Chapter 1: CA PMA Chargeback Overview

---

## CA Common Services for z/OS and OS/390

### ■ **Advanced Online Facilities**

CA PMA Chargeback™ uses the CA common Services for z/OS and OS/390 User Interface Management Services which incorporate advanced interactive techniques. Pull-down menus that open for various functions are featured. Direct navigation enables users to open multiple windows to best meet their needs. Prompt facilities display pop-up windows with choice lists to aid in entering data. These features are available in monochrome, color or extended attribute color formats. CA PMA Chargeback uses IBM SAA Common User Access standards to provide a common look and feel, in line with the CA Common Services for z/OS and OS/390 guiding principle to endorse and enhance established industry architectures and standard.

### ■ **Integration**

In line with the CA Common Services for z/OS and OS/390 principle to promote integration, CA PMA Chargeback supports all the interface history files produced by CA JARS® Resource Accounting providing integration with many software systems, subsystems and products including:

- MVS, VSE, VM, VAX VMS
- CA IDMS®/DB,™ CA Datacom®/DB, DB2, IMS, ADABAS
- CA Roscoe®, CICS, TSO, NetView
- CA 1®, BrightStor™ CA DYNAM®/TLMS

Since CA PMA Chargeback can be used in conjunction with your current resource accounting system, it preserves your investment in current software.

### ■ **Relational Database Structure**

CA PMA Chargeback takes advantage of the CA Common Services for z/OS and OS/390 Integration layer by using its Database Management Services. The CA PMA Chargeback database supports standard SQL capabilities and is designed to be fully capable of supporting all chargeback requirements.

### ■ **Security**

CA PMA Chargeback provides full-function security utilizing the CA Standard Security Facility (CAISSF) service of CA Common Services for z/OS and OS/390, providing access control with CA ACF2® Security for z/OS and OS/390. CA Top Secret® Security for z/OS and OS/390.

## Sharing Information with Other Products

### CA PMA Chargeback

- Accepts CA JARS history files as input.
- Creates a charge file than can be used as input to the general ledger system.

## Charging Options

### CA PMA Chargeback

#### ■ Flexible Rate Structure Definition

With CA PMA Chargeback you can define as flexible a rate structure as you need including variable rates for shift differentials, premiums and surcharges, minimum and maximum charges, and so forth. In other words, CA PMA Chargeback:

- Handles billing adjustments at several levels including debits and credits, overhead allocation, and cost recovery to provide flexibility when invoice modifications are required.
- Provides shift chopping to allow the expense of long-running jobs or tasks that span multiple shifts to be prorated according to the resources consumed within each shift.
- Offers split charging so that costs can be distributed across several accounting entities.

#### ■ Flexible Accounting Structure Definition

CA PMA Chargeback enables you to define your accounting structure to match your organizational environment. You can define up to five levels of accounting structure, each composed of three fields. Additionally, a table lookup facility is provided to translate the incoming accounting codes to user-defined values. Additionally, CA PMA Chargeback accepts user-defined accounting time periods that include flexible time boundaries which need not be based on calendar month.

#### ■ Unit Normalization

CA PMA Chargeback provides the ability to apply normalization or weighting factors to a specific resource unit. For example, CPU time from CPUs with different processing speeds can be normalized or standardized, thus providing the ability to define a single rate for multiple CPU models. This greatly simplifies rate definition.

## Other Features

- **Customized Queries**

CA PMA Chargeback provides powerful online query capabilities which allow you to view detail and summary budget and charge data. The query subsystem internally generates the appropriate SQL statements based on user criteria, providing the power of SQL without requiring familiarity with SQL. Queries can be generated and stored for future use, simplifying access to data by non-technical personnel.

- **Forecasting**

The CA PMA Chargeback forecasting feature projects past resource utilization into the future for budget and rate determination purposes. This feature allows you to modify forecasted utilization levels to assess the impact of potential changes in resource consumption.

- **Online Budget Control**

CA PMA Chargeback online facilities provide an easy-to-use method of defining budgets at any level of detail in the chargeback database. The online query facilities enable clients to examine budgets and charges online, to ensure that projects are completed within budget limitations.

- **Rate Determination**

The rate determination feature enables you to set up accurate rates for future accounting periods based on forecasted utilization levels and your cost recovery goals. You can perform "what if" analyses by changing rates and immediately seeing the impact on the total cost for each charge element or the total cost for the entire accounting period. Once you arrive at a set of rates that meet your cost recovery targets, they can be automatically generated and implemented in your current chargeback plan or they can be saved and implemented at a future date.

## What is CA PMA Chargeback

CA PMA Chargeback is a comprehensive and flexible application that performs chargeback for computing resources and services. It is designed to meet the needs of the novice and the more sophisticated user. CA PMA Chargeback takes advantage of CA Common Services for z/OS and OS/390 to promote integration, facilitate portability to other platforms and to provide a common user interface. It enables you to consolidate a comprehensive base of IS (Information Services) cost management data in a single application. This consolidation provides comprehensive invoices and reports.

CA PMA Chargeback provides advanced online facilities to perform:

- Rate specification
- Forecasting
- Rate determination
- Budgeting
- Adjustments
- Database queries

CA PMA Chargeback accepts CA JARS, CA Netman® and user-defined input. Input data is mapped by DataManager which generates a single output, the ORD (Output Record Definition) file. CA PMA Chargeback uses this file to perform the chargeback functions listed above.

## CA PMA Chargeback Input Sources

CA PMA Chargeback accepts input from the following sources via DataManager:

- CA JARS History Files including the following CA JARS interface history files:
  - CA JARS/ADABAS
  - CA JARS® for CICS (MVS & VSE)
  - CA Datacom/DB
  - DB2
  - CA JARS DSA Option
  - CA JARS/IDMS/DB (MVS & VSE)
  - CA JARS for IMS
  - CA Netman
  - NETVIEW
  - CA JARS/Roscoe
  - CA JARS TVA
  - CA JARS/VAX
  - CA JARS/VM
- CA JASPER: JSPSMF Glossary File
- CA Netman: 318 and 319 record
- User defined input

## CA PMA Chargeback Functional Overview

The processes used by the CA PMA Chargeback application fall into two major areas:

- Online functions
- Batch functions

However, there is **interaction** between online and batch functions.

## Online Functions

Online functions are invoked from a terminal. The following is a list of CA PMA Chargeback online functions:

Acctdefs Functions:	Enable you to define your accounting structure and sources, as well as create the CA PMA Chargeback construct (application identifier) that is appended to a CA PMA Chargeback output record. When you make changes to these tables, the changes have no effect on the actual operation of the product until they are <i>committed</i> (a batch process) and thus made active. These tables are created and maintained using the CA PMA Chargeback Acctdefs facility.
Cbdefs Functions:	Create the CA PMA Chargeback definition tables that control the product as a whole. When you make changes to these tables, the changes have no effect on the actual operation of the product until they are <i>committed</i> (a batch process) and thus made active. These tables are created and maintained using the CA PMA Chargeback Cbdefs facility.
Query Functions:	Allow you to view the contents of the CCCTAB, CCCMOD, BU DTAB, and Debit/Credit tables according to criteria you specify.
Data Entry Functions:	Provide a facility to enter actual data, rather than definitions, into the system. This includes budget amounts and manual financial adjustments, such as debits and credits. The results of data entry are immediately available via Query functions.
Period Functions:	Interrogate and modify the information contained on the specific CA PMA Chargeback database. Forecast, Rate Determination, and <i>What if</i> analysis are examples of Period functions.
Options:	Specify the options that you want in effect for an online session. This includes which version of the CA PMA Chargeback database you want to run against, whether you want to use mnemonics, have warning messages and Save/Delete prompts displayed, and so forth.

## Batch Functions

These functions fall into the following categories. Note that the Batch functions under this heading are all directly associated with the Batch Consolidation/LOAD process.

Detail Functions:	Are frequently run jobs. This category includes long running tasks, that would not be advisable to run online.
Period or Summary Functions:	Handle those conditions that cannot be dealt with until summarization of data occurs (calculation of charge elements).
Other Batch Functions:	Handle database maintenance.

## Detail Functions

Detail Functions are frequently run tasks concerned with the processing of CA PMA Chargeback records. For the CA PMA Chargeback application, the Detail functions handle four aspects of front-end processing:

- The definition of the application identifier (construct) that is appended to the detail records. This function is performed by DataManager, but construct definition is performed online using the Acctdefs option.
- The creation of records specific to the CA PMA Chargeback application: the charges.
- The summarization of these records and their placement in the CA PMA Chargeback CCCTAB table.
- Optional reconciliation file for detail charges.

Processing is controlled by the CA PMA Chargeback tables generated and maintained by the Table Maintenance functions' online component.

## Period or Summary Functions

Period Processing (**Summary Functions**) handles those conditions that cannot be handled at a detail level. That is, after charge elements have been calculated. This processing updates the CA PMA Chargeback tables.

Period Processing, as with detail functions, is controlled by the tables generated and maintained by the Table Maintenance functions' online component. Summary Functions include Overhead Distribution, Cost Recovery, Rate Determination, Forecasting, Invoicing, Period Open, and Period Close. Forecasting results can be viewed online; while batch processing is provided for efficient handling of data.

## Other Batch Functions

Other batch functions relate to database maintenance. They include:

- **Archive/Restore** allows your Database Administrators to Archive or Restore various versions of the DataManager and CA PMA Chargeback databases.
- **Commit Processing** allows your Database Administrator to make various versions of the DataManager and CA PMA Chargeback databases available to the system.

## CA PMA Chargeback Output

CA PMA Chargeback output falls into the following categories:

- CA PMA Chargeback reports and invoices generated using CA Earl®
  - Reconciliation Reports
  - Invoices
- Online Reporting
  - Query
  - Forecasting
  - Rate Determination
- Optional CA PMA Chargeback Reconciliation File
- CA PMA Chargeback Database

## CA PMA Chargeback Terms & Related Concepts

### Terms

The following information is an introduction to the concepts and terms that are used throughout this document.

## Chargeback Algorithm

An algorithm is a formula used to calculate a charge. Each algorithm is associated or *owned* by the charge element it calculates. In its simplest form, the chargeback algorithm is:

```

Charge          Charge
Unit * Rate = Element
|              |
|              | -- User-defined field that holds the
|              |      result of the calculation
|              |
|              | -- Can be either simple or conditional
|              |
|              | -- Can be simple or complex

```

All calculations start with the *charge unit* definition.

## Charge Unit

Defines a chargeable resource. It can be any numeric field name. A charge unit can be:

- **Simple:** An existing element defined within an output record definition. That is, a numeric field from the incoming record (ORD) used in the chargeback algorithm. Any numeric field in the record can be designated as a charge unit, and thus charged for.
- **Complex:** A user-defined name that is calculated from two or more existing output record fields. Note: You can also use constants.

## Rate

A multiplication factor. Rates can be:

- **Simple:** A constant.
- **Conditional/Qualified:** Where different rates are applied to a unit based on a qualifier (a true or false condition based on the contents or range of a field).

## Charge Element

A user-defined chargeable resource that holds the **result** of a chargeback algorithm (the charge). A charge element is always associated with a charge unit and an algorithm is *owned* by a charge element.

## Construct

A unique application **identifier** appended to a CA JARS data record by DataManager. The construct (key) allows each application to access the data in the most efficient manner.

**Note:** Only one construct is associated with each application, but an output record can have more than one construct associated with it.

## Modifiers

Used to make special changes to a charge, such as discounts and surcharges. Modifiers take the form of either an amount, or a percentage. If an associated conditional test is found to be true, then the modifier is applied to the calculated charge (the charge element).

## Normalizers

Give you the ability to **weight** the value of a charge unit. They are entered as percentages and always have qualifiers associated

## ORD Element

A source field that is defined within an incoming data record.

## ORDs

Output Record Definitions - predefined fixed definitions of the various different types of records contained within the JARS history files.

## Qualifiers

Are normally associated with a specific ORD record, and are used in **rate** selection, as well as with normalizers and modifiers. A qualifier is simply a user-defined test resulting in a true or false condition. For example,

Qualifier	Conditional Test
@SHIFT1	= START-TIME >= '800' and START-TIME < '1600'
@SHIFT2	= START-TIME >= '1600' and START-TIME < '2400'
@SHIFT3	= START-TIME >= '0000' and START-TIME < '0800'

## Unit

See Charge Unit definition.

## Version

An eight-character identifier that distinguishes different sets of chargeback definitions contained within CA PMA Chargeback definition tables and used in online definition and batch processing. CA PMA Chargeback processing is performed on tables that contain definitions/records for an infinite number of versions. A detailed discussion of Version is presented on Related Concepts.

- Development Version is a subset of Version. An eight-character identifier (either: TESTbbb or PRODbbb) that distinguishes the definitions that are modifiable via the CA PMA Chargeback online facility. Development version definitions **cannot** be used for processing until **commit** processing is performed.
- Committed Version is a subset of version. An eight-character identifier where the first four characters are either PROD or TEST. The second four characters can be any user-defined value. This identifier associates all CA PMA Chargeback definition tables with a respective committed DataManager version.

## Related Concepts

### Version

Version is a key concept because CA PMA Chargeback batch and online processing can be performed on tables that contain definitions/records for an infinite number of versions. CA PMA Chargeback processing validates its definitions and data against the DataManager tables. Therefore, CA PMA Chargeback **must** know which committed DataManager **version** to use in this process: PROD or TEST. There are two categories of versions: committed and Development (the uncommitted working version). The commit process *freezes* definitions. An **eight-character** identifier, called a version, distinguishes which table entries to use for processing and validation. You specify the version you want to use for processing and validation via the CAIKSPAR parameter file.

```
CA PMA Chargeback
|--- VERSION ---|
▼1 2 3 4 5 6 7 8▼
|_|_|_|_|_|_|_|_|
characters
```

The first character set (composed of characters one through four) tells you which **version** of the DataManager table entries you are running: either PROD (production) or TEST.

```
CA PMA Chargeback
|--- VERSION ---|
▼1 2 3 4 5 6 7 8▼
|_|_|_|_|_|_|_|_|
|P R O D|_|_|_|_|
|_|_|_|_|_|_|_|_|
▲
```

DataManager Version Identifier: PROD

The **complete** field, composed of characters one through eight: PRODTEST, is the version of the CA PMA Chargeback tables you are running. Remember, the CA PMA Chargeback version includes the four-character DataManager version identifier and a second four-character Version. For example:

```
CA PMA Chargeback
|--- VERSION ---|
▼1 2 3 4 5 6 7 8▼
|_|_|_|_|_|_|_|_|
▶ |P R O D|T E S T|
|_|_|_|_|_|_|_|_|
```

CA PMA Chargeback Version: PRODTEST

**Note:** Characters 5-8 can be any user-defined character string (A-Z, 0-9 only) exclusive of reserved characters. This is the version that you supply for the CBLOAD parameter in the CAIKRPAR parameter file discussed in CAIKRPAR Parameter File.

When you are creating or modifying CA PMA Chargeback definitions, the second set of characters reserved for the Version is blank. We refer to this condition as the Development version.

```

                CA PMA Chargeback
            |--- VERSION ---|
            ▼1 2 3 4 5 6 7 8▼
            |_|_|_|_|_|_|_|_|
            |P R O D|      |
            |_____|_____|
    CA PMA Chargeback Version: PROD_____
    
```

**Note:** The previous explanation does **not** apply to the following Acctdefs panels:

- Accounting Structure
- Accounting Sources
- Accounting Sources Lookup
- Accounting Periods

For these panels, the CA PMA Chargeback version appears as a four-character field. This field is a unique subset of the CA PMA Chargeback tables that:

- Is used within DataManager during daily LOAD processing to link the information contained within these tables with the appropriate record.
- Provides a mechanism for cross-validation during COMMIT processing

```

            -----
            |PROD|
            -----
              ▲
              |
    CA PMA Chargeback Version
    
```

You **must** *commit* your data using a batch process that makes your changes effective on the specified CA PMA Chargeback version's table entries.

## The Commit Process

This process **validates** the DataManager and CA PMA Chargeback definition sets. Commit processing allows you to commit the Development version (the version in process), either TESTxxxx or PRODxxxx to any user-defined second four character version identifier. The following diagram shows how this process works, where DEVELOPMENT is the version you edit, TEST is the version used for testing, and PROD is the version used in production.

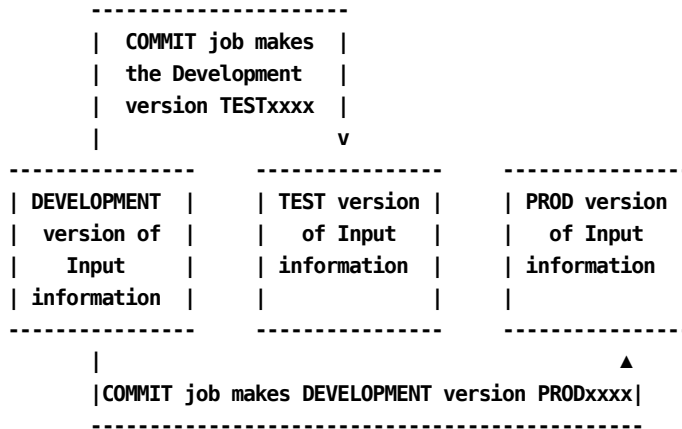

(Refer to the explanation of *version* provided on Related Concepts.)

## The Parameter Files

Global parameter files provide *static* definitions used by DataManager and CA PMA Chargeback in online and batch processing. There are two types of parameter files:

- **CAIKSPAR** is used by both DataManager and CA PMA Chargeback online and batch functions.
- **CAIKRPAR** is used in conjunction with the CAIKSPAR parameter file for CA PMA Chargeback batch processing.

These parameter files are accessed by the online dialogs and batch processes by the following ddnames: CAIKSPAR and CAIKRPAR.

**Note:** For CA PMA Chargeback batch processing, ORD (Output Record Definition) data record selection is dependent on the BASE\_VERSION specified in the CAIKRPAR parameter file.

---

## The CAIKSPAR Parameter File

The CAIKSPAR parameter file provides information about the database system as a whole, along with specific DataManager and CA PMA Chargeback parameters.

**Note:** You will find a detailed discussion of this file starting at CAIKSPAR Parameter File.

Both DataManager and CA PMA Chargeback online and batch facilities use the CAIKSPAR parameter file. It provides these facilities with the following information:

1. BASE\_VERSION =
2. CHARGE\_PREC =
3. CUSTOMER\_NAME =
4. DATABASE\_NAME =
5. PLAN\_ID =
6. RATE\_PREC =
7. SQL\_TYPE =
8. SUBSYSTEM\_ID =
9. UNIT\_PREC =

Parameter **1**, BASE\_VERSION =, is a four-character required field that must be either TEST or PROD. This parameter specifies the DataManager version that CA PMA Chargeback validates its data against. For example: BASE\_VERSION = TEST

Parameters **2, 6, and 9**, (CHARGE\_PREC =, RATE\_PREC =, and UNIT\_PREC =) control CA PMA Chargeback decimal precision. Precision affects calculations, as well as the populating of the database. Therefore, its effect is system-wide.

**Note:** Budget and Debit/Credit calculations and value display is **fixed** at five decimal places.

Parameters **4, 5, 7, and 8** specify the database product your installation uses and its requirements.

## The CAIKRPAR Parameter File

The CAIKRPAR parameter file defines CA PMA Chargeback batch processing parameters only.

**Note:** A detailed discussion of this file is provided on CAIKRPAR Parameter File.

The following parameters are defined in the CAIKRPAR parameter file:

1. BASE\_VERSION =
2. CBLOAD\_VERSION =
3. RECONCILIATION\_FILE =
4. PERIOD\_VERSION =

Parameter 1, BASE\_VERSION = , specifies the **first four characters** of the CA PMA Chargeback version tables (either PROD or TEST) you want to use for processing. ORD data record selection is dependent upon this parameter.

Parameter 2 CBLOAD\_VERSION = , specifies the **second four characters of the** CA PMA Chargeback version that will be processed. CBLOAD version names are user-defined, the following list is provided as an example:

```
CBLOAD_VERSION = TEST  
CBLOAD_VERSION = PROD  
CBLOAD_VERSION = WXYZ
```

*where* WXYZ is a user-defined version name

**Note:** User-defined version names can be between one to four characters.

Parameter 3, RECONCILIATION\_FILE = , is used to create an **optional** reconciliation file composed of variable length records. This file can consume a very significant amount of memory. The Reconciliation file shows in **detail** all charges, in segments, of every ORD. Refer to the discussion of CAKRLOAD in Chapter 11.

Parameter **4**, PERIOD\_VERSION = , is **optional**. It allows you to specify a CBLOAD Version that is associated with a period.

# CA PMA Chargeback Rules & Cautions

## How Information is Displayed on CA PMA Chargeback Panels

- Protected display field areas are preceded by a colon (:).
- You can determine the number of allowable characters for an entry field by the number of underscore characters displayed. In general, most character fields accept up to 16 alphanumeric characters.

## Specifying Search Strings

When specifying character strings for searches, you can use the SQL wildcard character, %, to represent either a single or multiple characters. You can specify it anywhere within the search string.

For example:

- To list all ORD (Output Record Definition) types starting with MB, specify: MB%. This yields: MBJ, MBP, MBS, and so forth.
- To list all ORD types containing a B as the second character, specify: %B%. This yields: MBJ, MBP, and so forth.

## Naming Conventions

- The following characters are reserved and should **not** be used in any name you supply to CA PMA Chargeback:
  - % (percent)
  - \_ (underscore)
- Most CA PMA Chargeback user-supplied names, unless otherwise noted, can consist of up to 16 alphanumeric characters, starting with an alpha character.
- User-defined names associated with complex charge units and qualifiers **must** be prefixed by the @ symbol.
- Using **ALL** as a qualifier ORD type, allows you to apply qualifier definitions to all ORDs globally.

## Specifying Numerics

- Charge, Rate and Unit precision are user-defined and specified in the CAIKSPAR parameter file.
- The higher the level of precision, the greater the **risk** of data overflow and hence lost data (integers) at the summarization level.
- When specifying numeric constants in qualifiers, the numeric **must** be enclosed in single quotes. For example, priority '9' or START-TIME =< '0800'.

## Qualifier Conventions

- When specifying constants in qualifiers, the constant **must** be enclosed in single quotes. For example, priority '9' or START-TIME =< '0800'.
- The following entries must be prefixed with the @ symbol:
  - A user-defined complex unit. For example, CPU-TIME, must be entered as @CPU-TIME. The @ symbol allows CA PMA Chargeback to differentiate between user-defined entry names and names that have a direct one-to-one relationship with ORDs available to the DataManager application.
  - Qualifier names, such as SHIFT1, SHIFT2 must also have the @ prefix: @SHIFT1, @SHIFT2.
- You can assign an ORD type of **ALL** to qualifier definitions. This means the qualifier is applied globally to all ORDs.
- ORD-specific qualifiers are always applied **before** global qualifiers (those with an ORD type of ALL).

## Panels You Will See When Using CA PMA Chargeback

In this section we discuss the main entry to the CA PMA Chargeback application, and some general points that are common throughout the system.

**Note:** CA PMA Chargeback can be run on both non-programmable color and monochrome terminals. A summary of terminal display standards that CA PMA Chargeback uses for displaying panels and fields is provided in Appendix B.

## The CA PMA Chargeback Primary Panel

To start the CA PMA Chargeback application, type: **PMACBC**. The CA PMA Chargeback Primary Panel appears.

### CA PMA Chargeback Primary Panel

```

USERID                      CA PMA Chargeback                      MM/DD/YY HH:MM:SS
---  Acctdefs  Cbdefs  Query  Data  Period  Options  Exit  Help
.
.
.
.      CCCCCC
.      CC      CC
.      CC
.      CC  AAAA          xxxxxxxx xx      xx xxxxx          xxxxxxx xxxxxxxx
.      CC  AAAAA        xx xx xxx  xxx xx xx      xx  xx xx xx  xx
.      CC  AA  AA        xx  xx xx x x xx xx  xx      x xx  xx  xx
.      CCAA  AA  xxxx  xxxxxxxx xx  x  xx xxxxxxxx  x  xx  xxxxxxxx
.      AACCCCAA        xx      xx      xx xx  xx  x  xx      xx  xx
.      AA      AA        xx      xx      xx xx  xx  x  xx      xx  xx
.      AA      AA        xx      xx      xx xx  xx  x  xx      xx xx  xx
.      AA      AA        xx      xx      xx xx  xx          xxxxxxx xxxxxxxx
.
.
.
Command ==>
F1=Help  F3=Exit  F4=Prompt  F9=Command  F10=Action Bar  F12=Cancel  PA1=Susp
    
```

A description of this panel is provided on the next page.

The following areas are available for selection:

#### Fast path entry area:

This two-character entry field allows experienced users to specify the *fast path* (no intervening menus or panels) to get to the panel or function they wish to perform. For example, enter **CC** where:

**C**

Represents the first character of an action bar keyword on the CA PMA Chargeback primary panel. In this case, C for Cbdefs. Other possibilities include Q for Query, D for Data, and so forth.

**C**

Represents an alphabetic mnemonic from an action bar pull-down. In this case, C for Charge Elements (see Action Bar Pull-Downs for a display of the Cbdefs pull-down).

#### Action Bar:

Lists actions you can access by tabbing to a specific keyword and pressing **ENTER**. When you make a selection, a **pull-down** appears that lists the available choices for the keyword you selected.

#### **Acctdefs**

(Accounting definition): Use this facility to define your accounting sources and structures. The following choices fall in the Acctdefs category:

- Accounting Structures
- Accounting Sources
- Period Tables

#### **Cbdefs**

(Chargeback definition): Use this facility to define your specific chargeback environment. The following choices fall in the Cbdefs category:

- Charge Elements
- Charge Units
- Qualifiers
- Normalizers
- Modifiers
- Split Job Charges
- Shift Chop
- Cost Recovery
- Overhead Distribution

#### **Query**

Allows you to query the following categories:

- Charge
- Budget
- Debit/Credit

#### **Data**

Provides a facility for entering chargeback-related data. Functions include:

- Budgets
- Debits/Credits

#### **Period**

These functions fall into the following categories:

- Forecasting
- Rate Determination

- MOD>TAB Copy

#### Options

Displays an Options pull-down that offers you the following choices (these choices allow you to override default settings for your userid):

- User Settings
- Versions

#### Exit

Displays a pull-down asking you if you are sure that you want to exit CA PMA Chargeback.

#### Help

Displays a pull-down with the following choices:

- Index
- Table of Contents
- Help for Help
- About: Tells you the genlevel of the CA PMA product you are using

#### Global Message Area:

Command processing messages are displayed in this area and may overlay data on the panel.

#### Command:

You use this entry area to type commands such as: EXEC, EXIT, HELP, CBDEFS, QUERY, and so forth. You can also execute the following commands from the command area:

- ? displays the last executed command
- = re-executes the last command
- = **pull-down panel name** displays the named pull-down

#### Global Function Keys:

Global function keys appear on the CA PMA Chargeback Primary Panel and are consistent across all product panels, **even** when they are not displayed.

##### F1=Help

Displays the Help panel behind the current panel.

##### F3=Exit

Terminates the current function.

##### F4=Prompt

Displays a pop-up window containing **choices** that can be inserted in the **entry** field where the cursor is positioned. F4 also works at the Command area. Remember, this function is dependent on the position of the cursor.

When you select a choice from the list, the pop-up window disappears. The choice text is then placed in the entry field as though you typed it there. You can also cancel the Choices pop-up window without making a selection using F12=Cancel.

**Note:** If you request a prompt when the cursor is **not** on an entry field, nothing happens. All entry fields have either a choices list or provides you with a descriptive message.

#### **F9=Command**

Positions the cursor at the command area and activates it. You can execute the following commands from the command area:

- ? displays the last executed command
- = re-executes the last command
- = **pull-down panel** name displays the named pull-down

#### **F10=Action Bar**

Pressing F10 activates a panel's action bar and positions the cursor at the first selection. (F10 toggles the action bar on and off).

#### **F12=Cancel**

Lets you cancel an action.

#### **PA1=Susp**

Lets you suspend processing for the currently active panel and activate the global action bar.

## Action Bar Pull-Downs

Action bar pull-downs appear when you position the cursor next to the function/keyword you want to invoke on an Action Bar and then press Enter. For example, if you select the Cbdefs keyword from the Primary Panel's action bar the following pull-down appears. It displays the available selections for Cbdefs.

```

USERID                               CA PMA Chargeback                               MM/DD/YY HH:MM:SS
--  Acctdefs  Cbdefs  Query  Data  Period  Options  Exit  Help
-----
      CB Definitions
      _ 1. Charge Elements
        2. Charge Units      (U)
        3. Qualifiers
        4. Normalizer
        5. Modifiers
        6. Split Job Charges
        7. Shift Chop        (B)
        8. Cost Recovery      (T)
        9. Overhead Distribution
-----
      F12=Cancel

Command ==>
F1=Help  F3=Exit  F4=Prompt  F9=Command  F10=Action Bar  F12=Cancel  PA1=Susp

```

- This entry field allows you to make a selection using a mnemonic which can be **either** the **number** or the **first letter** of a pull-down action. Notice that for those actions having duplicate first letters, the acceptable mnemonic is provided in parentheses. However, you can also make your selection by positioning the cursor next to the action you want to perform and pressing Enter.
- (U) indicates the acceptable mnemonic, **U**, to be used in the entry area when selecting this action.
- (B) indicates the acceptable mnemonic, **B**, to be used in the entry area when selecting this action.
- (T) indicates the acceptable mnemonic, **T**, to be used in the entry area when selecting this action.
- **Local Function Key Area:** Some function key assignments change from panel to panel. These *local* F (function) keys are shown at the bottom of each panel.
- **Global Function Key Area:** These standardized function key assignments appear on the bottom line of the Primary Panel. They work the same way on all CA PMA Chargeback panels.

**Note:** The following function keys are active when an action bar pull-down is displayed: F1 (Help), F3 (Exit), and F12 (Cancel).

### The Panel Pull-Down

All panels that have action bar pull-downs contain the keyword **Panel**. By activating the Action Bar (F10) and selecting the keyword **Panel** you can use this option to position or suspend panels.

```

USERID                               CA PMA Chargeback                               MM/DD/YY HH:MM:SS
---                               Query Data Period Options                               Exit Help
+-- CBCSTRE -- Accounting Structure -----+
|                                     Panel Exit Help                                     |
|-----|-----|-----|-----|-----|
| Typ   |         | save. |         |         |
|-----|-----|-----|-----|-----|
| Cha   |         | Panel |         |         |
|     1. |         | 1. Move |         |         |
|     2. |         | 2. Suspend |         |         |
|-----|-----|-----|-----|-----|
| 1.   |         |         |         |         |
| 2.   | DEPARTMENT |         |         |         |
| 3.   | GROUP      |         |         |         |
| 4.   |         |         |         |         |
| 5.   |         |         |         |         |
|-----|-----|-----|-----|-----|
| F5=Save |         |         |         |         |
+-----+-----+-----+-----+-----+

Command ==>
F1=Help F3=Exit F4=Prompt F9=Command F10=Action Bar F12=Cancel PA1=Susp
    
```

- Each time you select a keyword from an action bar, CA PMA Chargeback overlays the panel with another panel. When the new panel is active, you can choose from the options displayed there.
- Selecting **Panel** displays a pull-down that provides you with the following options:
  - **Move** gives you instructions on how to reposition panels on the screen.
  - **Suspend** allows you to interrupt a panel without erasing it from your screen. The other panels you display overlay suspended panels. By suspending one panel and then another, you can toggle back and forth between them. Toggling is accomplished by moving the cursor via the arrow keys to the panel you wish to activate and then pressing enter.

**Note:** Windows may also extend beyond the screen's edge. However, you cannot enter data into fields that aren't completely contained on the screen.

## The Exit Pull-Down

The Exit pull-down always appears when you select the Exit keyword from the action bar. It conditionally appears when you press F3 (Exit).

```

USERID                               CA PMA Chargeback                               MM/DD/YY HH:MM:SS
--   Acctdefs  Cbdefs  Query  Data  Period  Options  Exit  Help
+-- CBCSTRE -- Accounting Structure -----+
      Panel  Exit  Help
      -----
      Type infor
      Version:
      Struct  - 1. Save and exit
                2. Exit without saving
                3. Resume
      1. DIVISI
      2. REGION_____ 16
      3. DEPARTMENT_____ 16
      4. _____ --
      5. _____ --
      F5=Save
      -----+

Command ==>
F1=Help  F3=Exit  F4=Prompt  F9=Command  F10=Action Bar  F12=Cancel  PA1=Susp

```

Exit windows provide you with the following choices:

- **Save and exit:** Lets you back out one screen at a time, saving any changes or entries.
- **Exit without saving:** Lets you back out one screen at a time, without saving any changes or entries.
- **Resume:** Lets you carry on as though you never selected Exit.

## The Help Pull-Down

The Help pull-down appears when you select the Help keyword from the CA PMA Chargeback Primary Panel's action bar.

```

USERID                               CA PMA Chargeback                               MM/DD/YY HH:MM:SS
--   Acctdefs Cbdefs Query Data Period Options Exit Help
+-- CBCSTRE -- Accounting Structure -----+
    Panel Exit Help
-----+-----
    Type infor      Help
    Version:      _ 1. Index
                   2. Table of Contents
                   3. Help for Help
                   4. About ChargeBack
    Struct
    1. DIVISI
    2. REGION_____ 16
    3. DEPARTMENT_____ 16
    4. _____ --
    5. _____ --
    F5=Save
-----+-----

Command ==>
F1=Help F3=Exit F4=Prompt F9=Command F10=Action Bar F12=Cancel PA1=Susp
    
```

Help windows provide you with the following choices:

- **Index:** Displays a list of items, in alphabetical order, for which Help is available.
- **Table of Contents:** Displays a list of topics for which Help is available.
- **Help for Help:** Gives you information on how to use the Help system.
- **About:** Displays a pop-up window telling you the **genlevel** of the CA PMA product you are using.

## Windowing

When running the CA PMA Chargeback online facility, you'll encounter the following windows:

- **Primary:** Contain standard panels.
- **Pop-ups:** Extend the dialog with an underlying window (standard panel). Some examples of pop-up windows are the Prompt window, Are You Sure? window (section The Are You Sure? Window), Data Not Saved window (section The Data Not Saved Window), and Entry panel insert windows. Pop-ups cannot be moved or sized by users and do not have action bars.

**Note:** The following table summarizes the functions that are active/inactive when pop-up windows are displayed.

Active	Inactive
F1=Help	F4=Prompt
F3=Exit	F9=Command
F12=Cancel	F10=Action Bar
	PA1=Susp

### About (Genlevel) Pop-Up Window

To verify the **genlevel** of the CA PMA product you are using, you must select the Help keyword from the Primary Panel's action bar and then select **About**. A pop-up window appears telling you the genlevel of your product.

### Prompt Pop-Up Window

To use this feature, position the cursor at an input field for which you want information. When you press the global function key F4, a pop-up window containing *choices* appears. To select a choice, position the cursor next to the choice you want inserted in the field where the cursor is positioned and press Enter. This causes the pop-up window to disappear. Your choice appears in the entry field as though you typed it there.

**Note:** Remember, this function is dependent on the position of the cursor when you press F4.

This feature is very helpful when running CA PMA Chargeback. For example, suppose you are filling in fields on the Accounting Sources panel (shown below) and can't remember what ORD Type to use. Pressing F4 while the cursor is positioned at the ORD Type entry field causes CA PMA Chargeback to list the names of existing ORD Types so you can choose one.

```
USERID          CA PMA Chargeback          MM/DD/YY HH:MM:SS
---  Acctdefs  Cbdefs  Query  Data  Period  Options  Exit  Help
+--- CBCSRCP  ----- Accounting Sources -----+
|   Panel    Exit    Help
|-----+
| Type information. Then select an action.
|-----+
| Version .|          CHOICES
|-----+
| ORD Type | ORDID | DESCRIPT
| Structure|-----+
| F2=Creat | MBS  | MVS JARS BATCH STEP |
|          | MBJ  | MVS JARS BATCH JOB  |
|          | MBI  | MVS JARS BATCH I/O  |
|          | MBP  | MVS JARS BATCH PRINT|
|-----+
|-----+

Command ==>
F1=Help  F3=Exit  F4=Prompt  F9=Command  F10=Action Bar  F12=Cancel  PA1=Susp
```

You can also cancel the Choices pop-up window without making a selection using F12=Cancel.

**Note:** ORD Type display information comes from the DataManager version used to validate CA PMA Chargeback information. Refer to the discussion of the Options facility on Overview. Structure values are obtained from the CCCTAB's Development version.

## Entry Panel Insert Pop-Up Window

Entry panel insert pop-up windows appear when you enter an I in the Cmd column of an entry panel. Insert windows provide you with the same entry fields that are available on the panel from which it was invoked. Turn to Sample Entry Panel Insert Pop-Up Window for a further discussion of Entry panel Insert windows.

## The Data Not Saved Window

When you attempt to leave a panel without first saving its contents, this window appears.

```
-----  
|                                     |  
|  Data has not been saved  |  
|                                     |  
|  _ 1. Save and exit      |  
|    2. Exit without saving |  
|    3. Resume             |  
|                                     |  
-----
```

**Note:** The Are You Sure? panel is discussed in Chapter 9.

## Standard Panels

Most CA PMA Chargeback functions consist of a panel set (multiple panels). The standard access to these panels is shown in the diagram below.

The choices available at the standard Primary panel are to select a key to:

- Create an entry
- Browse a list of existing of entries

From the Browse List, you can select a specific entry in order to view its detail (its entry panel). Many Entry panels provide a pop-up Insert panel when an I is entered in the panel's Cmd column.

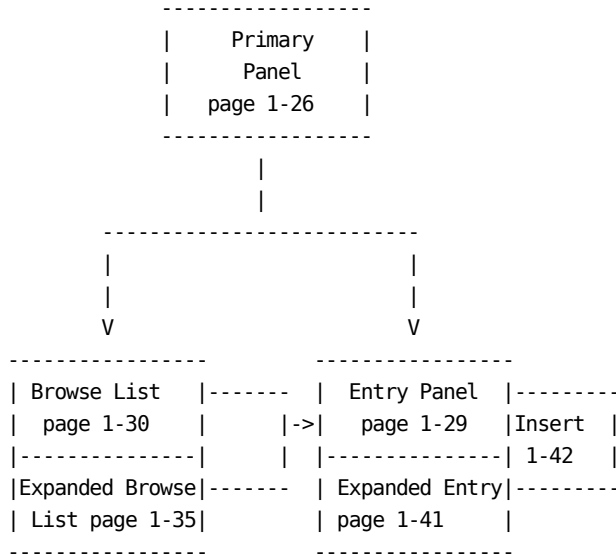

Behind each CA PMA Chargeback panel is a Help panel explaining how things work. For example, if you press F1 while you're using the Qualifier Entry panel, this Help panel appears:

```

+-- CBCQALEH ----- QUALIFIER ENTRY ----- HELP ----+
|
| The Qualifier Entry panel (CBCQALE) is used to define the range of a
| qualifier.
|
| Use the ORD Field/@Qualifier column to define the qualifier names.
|
| Rop (Relational operator) includes: < > = >= and <=
|
| Field/Constant means a field name or numeric constant that sets the
| boundary for the qualifier's test.
|

```

See Chapter 11 for a complete description of the CA PMA Chargeback Help facility.

## Sample Primary Panel

The following sample primary panel normally appears when you make a selection from an action bar pull-down. Use this panel to specify the criteria for the data you are interested in creating, viewing, or editing.

```

USERID          CA PMA Chargeback          MM/DD/YY HH:MM:SS
---  Acctdefs  Cbdefs  Query  Data  Period  Options  Exit  Help
+-- CBCELMP ----- Charge Elements -----+
|      Panel  Exit  Help
|-----+
|      Type information. Then select an action.
|
|      Version . . . : PROD
|      ORD Type . . . : MBJ
|      Charge Element . %
|
|      F2=Create  F11=Browse
+-----+

Command ==>
F1=Help  F3=Exit  F4=Prompt  F9=Command  F10=Action Bar  F12=Cancel  PA1=Susp
    
```

All primary panels have the following common panel areas:

This area displays the panel identifier and panel name:

```

+-- CBCELMP ----- Charge Elements ---
    
```

This action bar provides you with these options:

```

|      Panel  Exit  Help
|-----+
|
|
|
    
```

### Panel

Displays a window (see The Panel Pull-Down ) that provides you with the following options:

### Move

Gives you instructions on how to reposition panels and pull-downs against the background of the CA PMA Chargeback Primary Panel.

**Suspend**

Allows you to suspend the functioning of a panel and invoke other panels that overlay suspended panels. If you invoke panels from different sets, you can toggle between them.

**Exit**

Displays a window (see The Exit Pull-Down ) that provides you with the following choices:

**Save and exit:**

Lets you back out one screen at a time, saving any changes or entries

**Exit without saving:**

Lets you back out one screen at a time, without saving any changes or entries

**Resume:**

Lets you carry on as though you never selected Exit

**Help**

Displays the Help for Help panel. This panel tells you how to use the Help system. Refer to The Help for Help Panel for a detail discussion of this panel.

Use this area to specify the criteria for data that you want to browse, edit or create.

---

```
| Version . . . : PROD
| ORD Type . . . MBJ
| Charge Element . %
|
```

**Version**

Displays an eight-character protected field that tells you the version of the CA PMA Chargeback tables you are using. When you are creating or modifying CA PMA Chargeback data, characters five through eight appear as blanks. The Acctdefs panels are an **exception**. For these panels, Version appears as a **four-character** field. However, when you are creating or modifying CA PMA Chargeback data, these characters appear as blanks.

You must **commit** your data, if you are authorized, to make your changes effective on a specified CA PMA Chargeback database version. Or, arrange for your CA PMA Chargeback Administrator to commit your data.

**ORD Type**

The name (up to 3 alphanumeric characters) of the output record identifier you wish to create, view, or modify. If you do not know the ORD Type name, enter the SQL wildcard character %. This displays a list of all currently defined ORD Types that match the Charge Element you specify in the next field.

**Note:** If you enter an ORD Type that is not currently defined to the CA PMA Chargeback database, a message appears. Speak to the DataManager and CA PMA Chargeback Administrators to arrange for its definition.

### Charge Element

Type the name of the charge element you want to create, view, or modify. The SQL wildcard character % is not required.

Primary panels lead to list and entry panels using the following function keys:

```
-----  
|  F2=Create  F11=Browse  
+-----
```

- **(Create)** takes you to the entry panel
- **(Browse)** takes you to the list panel

### Sample List Panel

The following is a sample list panel. It appears when you press **F11** (Browse) on a primary panel. It presents a protected display of the criteria you specified on the primary panel, as well as a selection list of items meeting the criteria.

```

USERID          CA PMA Chargeback          MM/DD/YY HH:MM:SS
--  Acctdefs  Cbdefs  Query  Data  Period  Options  Exit  Help
+-- CBCEMLM ----- Charge Elements List -----+
|   Panel  Exit  Help
|-----|
|   Select charge element name. Then Enter.
|
|   Version . . . : PROD
|   ORD Type . . . : MBJ
|   Charge Element : %
|
|           More: - + ____ Row 0001 of 0004
|   ORD Charge Element
|
|   _ MBJ CPU-CHARGE
|   _ MBJ DISK-CHARGE
|   _ MBJ TAPE-CHARGE
|   _ MBJ TOT-CPU
|
|           Enter  F7=Bkwd  F8=Fwd  F11=Expand
+-----+
Command ==>
F1=Help  F3=Exit  F4=Prompt  F9=Command  F10=Action Bar  F12=Cancel  PA1=Susp
    
```

List panels have the same common panel areas described under Sample Primary Panel in the previous section with the following additions:

```

| More: - + ____ Row 0001 of 0003 |
    
```

This area is called the scroll bar; it serves several purposes:

- It tells you your location within a list.
- You can enter the row you want to view by typing its number in the Row entry area and pressing Enter. The named row appears at the top of the list.
- You can scroll backward and forward a specific number of rows by typing the number of rows you want to scroll in the entry area following the - (minus) and + (plus) symbols and using your F7 or F8 key to indicate the scrolling direction.

Using the entry area following the - (minus) and + (plus) symbols, you can indicate one of the following scrolling increments:

- a specific **number** of rows you want to scroll
- **page** displays only new lines (no carry over)
- **data** repeats just the first or last line on the next panel

- **csr** (cursor) moves the line containing the cursor to the top or bottom of the list. Then, place the cursor on the + or - to indicate the direction you want to scroll in.

```
|  ORD  Charge Element
```

Column headings used to clarify the categories of data returned that match the search criteria you specified on the primary panel:

- **ORD** is the output record definition identifier.
- **Charge Element** is the user-defined name containing the charge for a specific resource.

```
|  ORD  Charge Element
|
|  MBJ  CPU-CHARGE
|  MBJ  DISK-CHARGE
|  MBJ  TAPE-CHARGE
```

This area lists all the charge elements presently defined for the ORD Type specified on the primary panel - in this case: MBJ.

```
|  Enter  F7=Bkwd  F8=Fwd  F11=Expand
```

List panels allow you to perform the following actions:

#### Enter

Lets you select an item for detailed examination. Place the cursor next to the item you want to view and press **Enter**. This action takes you to the entry panel for the selected item.

#### F7

Lets you scroll backwards through the display.

#### F8

Lets you scroll forward through the display.

#### F11

Takes you to the expanded list panel.

### Sample Expanded List Panel

The following is a sample **expanded** list panel. It appears when you press **F11** (Expand) on the List panel. This panel functions in the same manner as the list panel. It gives you an eight-line, rather than a five-line display of data that matches the search criteria you specified on the primary panel. This is because the Browse criteria information contained on the standard List panel is not displayed.

```
USERID                CA PMA Chargeback                MM/DD/YY HH:MM:SS
--  Acctdefs  Cbdefs  Query  Data  Period  Options  Exit  Help
+-- CBCELMX ---- Expanded Element List -----+
|                                     |
|                                     |
| Select charge element name. Then Enter. |
|                                     |
|                                     |
| More: - +          Row 0001 of 0005 |
| ORD Charge Element |
|   _ MBJ CPU-CHARGE |
|   _ MBJ DIO-CHARGE |
|   _ MBJ TOT-CPU    |
|   _ MBP LASER-CHARGE |
|   _ MBP PRINT-CHARGE |
|   _                |
|   _                |
|   _                |
| Enter  F7=Bkwd  F8=Fwd |
+-----+
Command ==>
F1=Help  F3=Exit  F4=Prompt  F9=Command  F10=Action Bar  F12=Cancel  PA1=Susp
```

## Sample Entry Panel

Entry panels are used to create, modify, and delete data. They appear when you:

- Press **F2** (Create) on the primary panel
- Position the cursor next to an item on a list or expanded list panel and press **Enter**
- Select an action from a pull-down or another entry panel that exists only as an entry function

```

USERID                      CA PMA Chargeback                      MM/DD/YY HH:MM:SS
--  Acctdefs  Cbdefs  Query  Data  Period  Options  Exit  Help
+-- CBCELMU ----- Charge Units Entry -----+
|
|   Panel  Exit  Help
|-----|
|   Type information. Then select an action.
|
|   Version . . : PROD
|   ORD Type . . : MBJ
|   Charge Unit : TOT-CPU
|
|   More:  - + _____ Row 0000 of 0000
|   Cmd  ORD Field/@Unit  Aop Field/Constant  Aop
|
|   SRB-TIME_____ * '.5' _____  +
|   TCB-TIME_____ * '.5' _____  -
|   _____ - _____ -
|   _____ - _____ -
|
|   F2=Xref F5=Save F6=Delete F7=Bkwd F8=Fwd F11=Expand
+-----+
Command ==> _____
F1=Help  F3=Exit  F4=Prompt  F9=Command  F10=Action Bar  F12=Cancel  PA1=Susp

```

Entry panels have the same common panel areas described in the previous sections, with the addition of column headings used to clarify the categories of data returned and input areas that are available to you:

---

**Cmd** **ORD Field/@Unit** **Aop** **Field/Constant** **Aop**

---

### Cmd

Use this column to specify commands. Valid commands include D for delete and I for insert, which provides you with a pop-up window that prompts you for the information you want inserted into the table.

### ORD Field/@Unit

Can refer to either a valid field defined in the ORD or another user-defined charge unit (indicated by the @ prefix) applying to the same ORD.

### Aop

Use this column to indicate any arithmetic operations you want performed. Acceptable operators are: + (plus), - (minus), \* (multiply), and / (divide).

**Field/Constant**

You use this column when you want a charge unit's value to be calculated based on either the contents of another field's value or a constant.

**Aop**

Use this column to indicate how you want a calculation **linked** to any operations that follow. Acceptable operators are: +, -, \*, and /.

This area lists all the units presently defined for the ORD specified on the primary panel - in this case, MBJ.

MBJ SRB-TIME	*	'100'		
MBJ TCB-TIME	*	'200'		

Entry panels may differ in the function keys they provide. However, standard entry panel function keys include:

F5=Save F6=Delete F7=Bkwd F8=Fwd
+-----

**F5**

Saves your data to disk

**F6**

Deletes all entries

**F7**

Lets you scroll backwards through the display

**F8**

Lets you scroll forward through the display

## Sample Expanded Entry Panel

The following is a sample *Expanded* Entry panel. Expanded Entry panels are displayed when you press **F11** on an entry panel. Expanded Entry panels function in the same way as entry panels. The only difference between an Entry panel and Expanded Entry panel is the protected fields are not displayed. This allows you to view more information on a single panel.

```

USERID          CA PMA Chargeback          MM/DD/YY HH:MM:SS
--  Acctdefs  Cbdefs  Query  Data  Period  Options  Exit  Help
+-- CBCELMV ----- Expanded Units Entry -----+
      Panel  Exit  Help
-----+-----
      Type information. Then select an action.

                          More: - + _____ Row 0001 of 0002
      Cmd  ORD Field/@Unit  Aop Field/Constant  Aop
          SRB-TIME_____ *  '.5'_____ +
          TCB-TIME_____ *  '.5'_____ -
          _____ - _____ -
          _____ - _____ -
          _____ - _____ -
          _____ - _____ -
          _____ - _____ -
          _____ - _____ -
          F2=Xref  F5=Save  F6=Delete  F7=Bkwd  F8=Fwd
+-----+-----

Command ==> _____
F1=Help  F3=Exit  F4=Prompt  F9=Command  F10=Action Bar  F12=Cancel  PA1=Susp

```

## Sample Entry Panel Insert Pop-Up Window

To invoke an Insert window, enter an arithmetic operator in the second Aop field of the entry **preceding** the row where you want to perform the insert. Next, type an I in the Cmd column for this row; then press Enter. The pop-up Insert window displays.

```

USERID          CA PMA Chargeback          MM/DD/YY HH:MM:SS
---            +-----+
+-- CBCELMU ----- Charge Units Entry -----+
|   Panel  Exit  Help  |
|-----|
|   Type information. Then select an action.   |
|   Version . . : PROD                         |
|   ORD Type . . : MBJ                         |
|   Charge Unit : TOT-CPU                       |
|                                               |
|               More: - + _____ Row 0001 of 0002 |
| Cmd  ORD Field/@Unit  Aop Field/Constant  Aop  |
|-----|-----|-----|-----|
| I   SRB-TIME_____ *  '.5'_____  +      |
| I   TCB-TIME_____ *  '.5'_____  > +      |
| >   _____  -   _____  -          |
| -   _____  -   _____  -          |
| -   _____  -   _____  -          |
|                                               |
|   F2=Xref F5=Save F6=Delete F7=Bkwd F8=Fwd F11=Expand |
+-----+
Command ==> _____
F1=Help F3=Exit F4=Prompt F9=Command F10=Action Bar F12=Cancel PA1=Susp
    
```

The following is a sample Entry *Insert* window. Insert windows provide you with the same entry fields that are available on the panel from which it was invoked. However, while the window is visible, the **only** functions available to you are F5 (Save), F3 (Exit), and F12 (Cancel).

```

USERID                               CA PMA Chargeback                               MM/DD/YY HH:MM:SS
--  Acctdefs  Cbdefs  Query  Data  Period  Options  Exit  Help
+-- CBCELMU ----- Charge Units Entry -----+
|   Panel  Exit  Help
|-----+
|   Type information and save. Then select an action.
|   +-- CBCUMII ----- Unit insert -----+
|   |
|   |   Enter unit data. Then save.
|   |
|   |   ORD Field / @Unit . WAIT-TIME_____
|   |   Aop . . . . . *
|   |   Field / Constant . . '.5'_____
|   |   Aop . . . . . _
|   |
|   |   F5=Save
|   |-----+
|-----+
|
|   F2=Xref F5=Save F6=Delete F7=Bkwd F8=Fwd F11=Expand
+-----+

Command ==> _____
F1=Help  F3=Exit  F4=Prompt  F9=Command F10=Action Bar  F12=Cancel  PA1=Susp
    
```

After completing the insert, press F5. The information is always inserted on the Entry panel on the line **after** the one where you typed the I.

```

USERID                               CA PMA Chargeback                               MM/DD/YY HH:MM:SS
--  Acctdefs  Cbdefs  Query  Data  Period  Options  Exit  Help
+-- CBCELMU ----- Charge Units Entry -----+
|   Panel  Exit  Help
|-----+
|   Type information. Then select an action.
|
|   Version . . : PROD
|   ORD Type . . : MBJ
|   Charge Unit : TOT-CPU
|
|   More: - + _____ Row 0001 of 0003
|   Cmd  ORD Field/@Unit  Aop Field/Constant  Aop
|-----+
|   -   SRB-TIME_____ * '.5'_____ +
|   -   TCB-TIME_____ * '.5'_____ +
|   -   WAIT-TIME_____ * '.5'_____ -
|   >  -   _____ - _____ -
|   -   _____ - _____ -
|
|   F2=Xref F5=Save F6=Delete F7=Bkwd F8=Fwd F11=Expand
+-----+

Command ==> _____
F1=Help  F3=Exit  F4=Prompt  F9=Command F10=Action Bar  F12=Cancel  PA1=Susp
    
```

## Function Key Summary

Function keys enable you to navigate through the CA PMA Chargeback application and perform various actions. Some function keys apply to all panels while others are panel specific.

**Note:** All panels described in this guide contain information on how their function keys operate.

## Global Function Keys

The following is a list of **global** function key assignments for the CA PMA Chargeback application. They appear on the CA PMA Chargeback Primary Panel and are consistent across all product panels, **even** when they are not displayed.

### **F1=Help**

Provides a Help panel for the current panel.

### **F3=Exit**

Terminates the current function.

### **F4=Prompt**

Displays a pop-up window containing **choices** that can be inserted in the **entry** field where the cursor is positioned. You can also use F4 at the command area. Remember, this function is dependent on the position of the cursor when requesting a prompt using F4 (see Prompt Pop-Up Window).

When you select a choice from the list, the pop-up window disappears. The choice text is then placed in the entry field as though you typed it there. You can also cancel the Choices pop-up window without making a selection using F12=Cancel.

**Note:** If you request a prompt when the cursor is not on an entry field, nothing happens. All entry fields have either a choices list or provide you with a descriptive message.

### **F9=Command**

Positions the cursor at the command area and activates it. You can execute the following commands from the command area:

- **?**  displays the last executed command
- **=**  reexecutes the last command
- **= pull-down panel name**  displays the named pull-down

### **F10=Action Bar**

Pressing F10 activates a panel's action bar and positions the cursor at the first selection. (F10 toggles the action bar on and off).

### **F12=Cancel**

Lets you cancel an action.

### **PA1=Susp**

Lets you suspend processing for the currently active panel and activate the global action bar.

## Local Function Keys

Local function keys only work for the panel that displays them. Each panel description explains how its local function keys work.

## CA PMA Chargeback Relational Characteristics

CA PMA Chargeback uses relational concepts to create and manipulate data in its database. These characteristics ensure the following:

- Centralized data storage and management
- Eliminate the need for multiple products to process the same data
- Allow data to be shared across products

By centralizing data, redundancies in data collection, processing, and storage are eliminated.

Relational database structure is basically a simple matrix of records (rows) and fields (columns). All CA PMA Chargeback data is stored in tables that possess the following characteristics:

### Column

A column is the vertical component of a table. Columns are used to describe an indivisible unit of data. Each column has a name and a specific data type, such as character or integer. While the order of columns in a table is fixed, there is no conceptual significance to this order. Columns are frequently referred to as **fields**.

### Row

A row is the horizontal component of table. A row is a sequence of values, one for each column of the table. Each row contains the same number of columns. Rows are frequently referred to as **records**.

**Note:** You insert and delete rows, whereas you update individual columns. Furthermore, a table can exist without any rows, but not without any columns.

Tables are two-dimensional, they consist of a matrix of information composed of rows and columns:

- Depth is the number of rows within a table.
- Width is the number of columns within a row.

The CA PMA Chargeback database is made up of two types of tables:

- **Definition Tables:** Contain primarily user-defined input that defines the actual CA PMA Chargeback processing environment and controls the logic of the system.
- **Data Tables:** Contain data produced by the application detailing the charges, and so forth.

## CA PMA Chargeback Tables

The following list gives a brief description and definition of the chargeback tables that are distributed with CA PMA Chargeback. These tables contain ORDs (Output Record Definitions). Note that ORDs can only be modified using DataManager. However, you can modify these tables to meet your data center's requirements using the CA PMA Chargeback **Table Maintenance Function**. A complete description of each table, as distributed, is provided in Appendix A.

## Definition Tables

### **ACCSTTAB\***

(Accounting Structure Table): Defines the organizational hierarchy that is maintained on the CA PMA Chargeback database. This table along with the ACCSRTAB, ACCTLOOK, and PERTAB definition tables are used to create the CA PMA Chargeback construct.

### **ACCSRTAB\***

(Accounting Sources Table): Contains the information required to define sources for each accounting structure level.

### **ACCTLOOK\***

(Lookup Table): Associates raw accounting entity values with meaningful organizational names.

### **PERTAB\***

(Period Table): Defines fixed accounting periods across the CA PMA Chargeback system.

\* The above tables are used by CA PMA Chargeback during processing, as well as DataManager during output record generation. As such, these tables' version reference the DataManager version.

### **ELEMTAB**

(Charge Element Table): Defines the elements used to calculate default charge element values.

### **NORMTAB**

(Unit Normalization Table): Defines normalization or weighting factors applied during charge unit value calculation.

### **UNITTAB**

(Charge Unit Table): Defines the formula used for calculating charge unit values.

### **RATETAB**

(Charge Algorithm Table): An algorithm is a formula that associates a rate with a qualifier. This table contains the **qualified** (conditional) rates.

### **QUALTAB**

(Qualifier Table): Defines Qualifier definitions that associate a qualifier with an algorithm.

## Definition Tables (Continued)

### **MODTAB**

(Charge Modifier Table): Defines conditions that modify the calculated charges for reasons such as vacation discounts, priority weighting, class weighting and so forth.

### **QUERYTAB**

(Saved QUERY Table): Defines queries that are stored by name, for later retrieval and use.

### **SPLITTAB**

(Split Resource Table): Defines the conditions under which a charge associated with a given job or task executed on behalf of several users is split among those users.

### **CHOPTAB**

(Shift Chopper Table): Defines the times at which records associated with long running tasks are to be chopped and prorated records generated.

### **SUMTAB**

(Summary Functions Table): Defines which records are selected at the end of a period.

### **OPTTAB**

(Option Settings Table): Defines user options, by userid, so that each user's settings are saved individually.

## Data Tables

### CCCTAB

(Consolidated Calculated Charges Data Table): Contains the information used by **all** CA PMA Chargeback functions. It is created and maintained by the **Detail** (batch) functions and is a summary table of the output records' processed data. Each item kept in the CCCTAB table is a line item on an invoice. The table is maintained with a unique key comprised of the Accounting Structure, Period, Charge Element, and Qualifier. Information contained is:

- Number of units
- Rate
- Charge
- Number of ORD records that constitute each CCCTAB record

The CCCTAB table is the **principal** CA PMA Chargeback information data table.

### CCCMOD

(The *Scratchpad* Table/Modified Consolidated Calculated Charges Table): Is generated by the batch Forecast process and used by the Period functions to display and modify forecasted periods/rates, as well as by the Query function for displaying data. It exists so that these calculations are not applied directly to the *live* CCCTAB table.

### BUDTAB

(Budget Table): Contains budget information that is entered online via the Budgets facility and is immediately available via the Query facility. This information is also used for invoice generation. This table is used in conjunction with the CCCTAB table.

### DBCRTAB

(Debit and Credit Table): Contains credit and debit manual adjustments that are entered online using the Data Entry facility. Adjustments are immediately available for viewing via the Query facility. This information is also used for invoice generation in conjunction with the CCCTAB table.

## Internal Tables

The following tables are CA PMA Chargeback internal tables and are not to be modified.

- ACCTCMD
- ACCTDISP
- EDITTAB
- VALTAB
- BSATCMD
- BSATDISP



# Chapter 2: CA PMA Chargeback & DataManager Interrelationships

---

## Overview

DataManager formats input data for use by Performance Management and Accounting applications. IRDs (Input Record Definitions) and ORDs (Output Record Definitions) for supported products are included with DataManager. The CA PMA Chargeback application interacts with DataManager **continuously** to:

- Build the CA PMA Chargeback application identifier (construct)
- Define CA PMA Chargeback accounting structure
- Define CA PMA Chargeback accounting sources
- Translate the above into meaningful labels that associate accounting entities with meaningful organizational names
- Define accounting periods
- Validate the existence and correctness of data as users enter information into CA PMA Chargeback.

In order for all these events to occur, the following steps must be implemented:

1. Archive all DataManager tables for recovery purposes (CAKSARCH)
2. Customize DataManager and CA PMA Chargeback.
3. Commit DataManager (described in detail in the *DataManager User Guide*)
4. Commit CA PMA Chargeback: CAKRCOMT
5. Archive (Backup) customized definitions: CAKSARCH

The above steps are performed by running the batch jobs discussed in Chapter 11.

## Version Interrelationships

CA PMA Chargeback processing can be performed on an infinite number of versions. CA PMA Chargeback processing validates its definitions and data against the DataManager tables. The CAKRLOAD process and its associated CAIKRPAR parameter file require the DataManager version in order to validate and process CA PMA Chargeback data against the appropriate DataManager table entries. An **eight-character** identifier, called a version, distinguishes which table entries are used for processing and validation.

The first four characters of the version tell you which **version** of DataManager you are running: either PROD (production) or TEST.

```
          CA PMA Chargeback
        ---- VERSION ----
        ▼1 2 3 4 5 6 7 8▼
        -----
        |P R O D|A B C D|
        -----
DataManager Version Identifier: PROD
```

**Note:** The previous explanation does **not** apply to the Acctdefs panels. For these panels (described in the next chapter), the CA PMA Chargeback Version appears as a **four-character** field. This field is a unique subset of the CA PMA Chargeback tables that:

- Is used within DataManager during daily CAKSLOAD and CAKRLOAD processing to link the information contained within these tables with the appropriate record
- Provide a mechanism for cross-validation during CA PMA Chargeback commit processing

```
        -----
        |PROD|
        -----
          ▲
          |
CA PMA Chargeback Version
```

Refer to Versions for a discussion of how to specify versions online using the CA PMA Chargeback Option facility.





# Chapter 3: Setting Up Your Accounting Structure

---

## Overview

Before you can begin using CA PMA Chargeback, DataManager must know how each application needs to have its data keyed. This is achieved by having each PMA application create its own **construct** (an application identifier) that is appended to a DataManager output record (ORD). While each application is identified by a unique construct, a record can have more than one construct associated with it. In other words, a record can be used by more than one application. That means ORD data records can have several 'C'type fields, each for a different application's construct.

The definition of information required for this process falls under the category of Table Maintenance Functions and is handled by CA PMA Chargeback **Acctdefs** tasks.

Accounting definition functions are invoked when you select **Acctdefs** by placing the cursor next to Acctdefs keyword on the CA PMA Chargeback Primary Panel's action bar and pressing Enter. The Acctdefs pull-down shown on page Overview appears. The Acctdefs pull-down presents you with three choices that are used in creating the CA PMA Chargeback construct:

- 1**  
Accounting Structure
- 2**  
Accounting Sources (R)
- 3**  
Period Tables

**Note:** Construct definition is normally the responsibility of the CA PMA Chargeback Administrator working in concert with the DataManager Administrator. Construct definition is usually a onetime only task occurring during implementation. However, when additional records are required for processing, some functions may need to be repeated.

**Acctdefs Pull-Down**

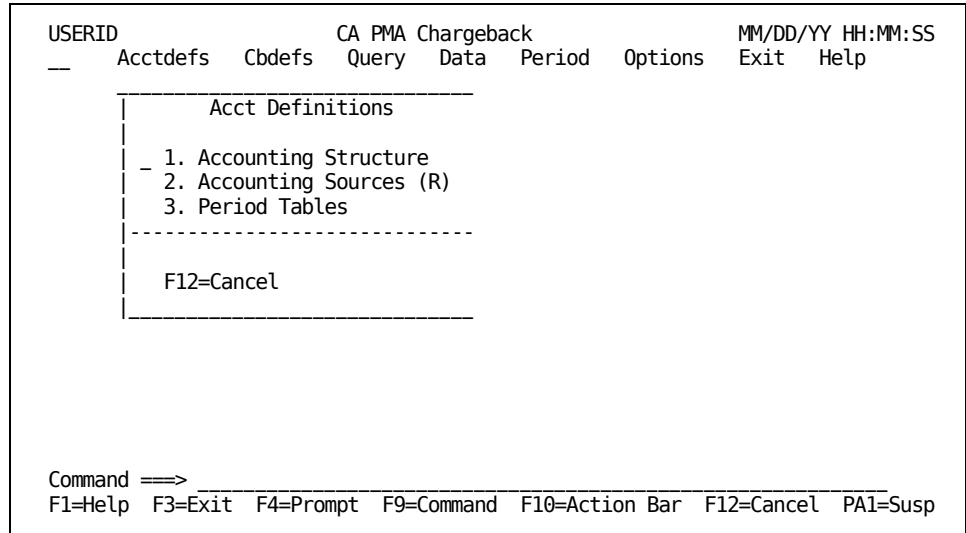

A 1-character field allows you to make a selection using a mnemonic that can be either a number or the first letter of an action. Note that when actions have duplicate first letters, you can use either the number or the letter supplied in parentheses.

You can also make your selection by tabbing the cursor next to the action you want to perform and pressing Enter.

An overview of the Acct Definitions options used in construct building is provided below.

**1. Accounting Structure**

Lets you define up to five accounting levels within your organization.

**2. Accounting Sources**

Enables you to specify the ORD field name(s) (the source fields) from the DataManager output record definitions that contain the value(s) for each level of your accounting structure.

**3. Period Tables**

Enables you to maintain fixed periods across all ORD input records. The PERTAB Table, an accounting period definition table, is maintained to specify the date and time for a given period. This data is used to indicate the period to which a given detail record is allocated.

## Accounting Structure Panel

The CA PMA Chargeback Administrator uses this panel to define your organization's accounting structure to CA PMA Chargeback and DataManager.

The Accounting Structure panel updates the ACCSTTAB table with the names of up to five user-defined accounting entities.

You can define up to five accounting levels and assign a name (up to 16 alphanumeric characters) for each level. For example, Division, Department, Section, Group-ID, and Team.

Each structure supports up to 16 positions composed of the combined length of the ORD field names you specify on the Accounting Sources Entry panel shown on Accounting Sources Entry Panel. You **must** press F5 (Save) to save your accounting structure definition.

The contents of the protected display field, Version, is determined by information you specify using the Options facility. See Versions for further details. The Version **must** be PROD, TEST or appear as blanks. Blanks indicate you are using the Development version. Remember, you can only update a Development version.

```

USERID                               CA PMA Chargeback                MM/DD/YY HH:MM:SS
--  Acctdefs  Cbdefs  Query  Data  Period  Options  Exit  Help
+-- CBASTRE -- Accounting Structure -----+
|      Panel  Exit  Help
|-----+
|      Type information. Then save.
|
|      Version :
|
|      Structure          Length
|
|      1. DIVISION_____ 16
|      2. DEPARTMENT_____ 16
|      3. SECTION_____ 08
|      4. GROUP-ID_____ 08
|      5. TEAM_____ 04
|
|      F5=Save
+-----+

Command ==> _____
F1=Help  F3=Exit  F4=Prompt  F9=Command  F10=Action Bar  F12=Cancel  PA1=Susp

```

**Caution** Accounting Structure assignment is **mandatory**. At least one entity must be defined.

The following is a description of the Accounting Structure panel.

### Access

The Accounting Structure panel appears when one of these events occurs:

- You type AA in the fast path area of the CA PMA Chargeback Primary Panel's action bar.
- You select Acctdefs on the Primary Panel's action bar and then choose Accounting Structure on the Acctdefs pull-down.

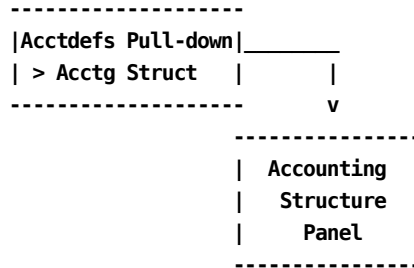

**Input**

The following Accounting Structure panel fields are available for input:

**Structure**

An organizational structure name of up to 16 alphanumeric characters. For example, division, department, and so forth.

**Length**

The combined length of up to three ORD fields, defined in the ORD Field Name column of the Accounting Sources Entry panel (page Accounting Sources Entry Panel).

**Note:** Each structure's length **cannot** exceed 16.

**Actions**

**F5**

**(Save)** Saves the accounting structure definition.

## Defining Your Accounting Sources

Unlike the Accounting Structure table which has only one panel, the Accounting Sources table uses multiple panels. The following panels make up the Accounting Sources panel set:

- Accounting Sources primary panel
- Accounting Sources List panel
- Accounting Sources Expanded List panel
- Accounting Sources Entry panel
- Accounting Sources Lookup Table panel
- Accounting Sources Lookup Table Insert panel

**Note:** All protected display field areas are preceded by a colon (:).

These panels enable the CA PMA Chargeback Administrator to define the source field(s), ORD field(s), that supply the value for each level of your accounting structure. For each ORD record used by the CA PMA Chargeback application, there exists an Accounting Sources record detailing the source for each entry in the Accounting Structure (ACCSTTAB) table.

Each level of the structure can be comprised of up to three source fields/subfields. An optional lookup table facility is available for each organizational level you define. See *Creating a Lookup Table* for a discussion of this feature.

**Note:** Accounting sources must be specified for each ORD type you define to the CA PMA Chargeback application and should be consistent across all ORD types.

Each time you perform a SAVE, CA PMA Chargeback checks the DataManager Table to validate each entry's existence.

It is strongly recommended that you define ORD types with meaningful names. ORD names are composed of three alphanumeric characters according to the following convention:

**For example - MBJ**

**where:**

**M**

Represents the operating system, in this case: MVS

**B**

Represents the subsystem, in this case: BATCH

**J**

Represents the record type, in this case: JOB

## Accounting Sources Primary Panel

Accounting Sources definition starts with the Accounting Sources primary panel. You specify, at the ORD Type prompt, a **key** for browsing or defining data.

In the example below, the key for ORD Type is MBJ (MVS Batch Jobs). For Structure, it is the SQL wildcard character %. The contents of the protected display fields: Version and DM Version is determined by information you specify using the Option facility (see Versions for details). The DM Version field tells you the DataManager version used to validate and commit your constructs and definitions. It must be PROD or TEST.

**Note:** When using the Accounting Sources panel set:

- The Version field must be blank if you are creating or editing constructs or definitions.
- To view constructs for a committed CA PMA Chargeback version, you must first use the Options facility to specify the Version you want to browse. For example, PRODABCD. When the Accounting Sources panel appears, the Version protected field displays as ABCD (see the sample panel below). Then, press F11 to browse accounting sources data.

```

USERID                CA PMA Chargeback                MM/DD/YY HH:MM:SS
---  Acctdefs  Cbdefs  Query  Data  Period  Options  Exit  Help
+-- CBASRCP  ----- Accounting Sources -----+
|
|   Panel  Exit  Help
|-----|
|   Type information. Then select an action.
|
|   Version : ABCD                DM Version : PROD
|
|   ORD Type . . MBJ
|   Structure . %_____
|
|   F2=Create  F11=Browse
+-----+

Command ==> _____
F1=Help  F3=Exit  F4=Prompt  F9=Command  F10=Action Bar  F12=Cancel  PA1=Susp
    
```

Next is a description of the Accounting Sources primary panel.

### Access

The Accounting Sources primary panel appears when one of these events occurs:

- You type AR in the fast path area of the Primary Panel's action bar.

- You select Acctdefs on the Primary Panel's action bar and then choose Accounting Sources on the Acctdefs pull-down.
- You return to this panel using **F3** from the Accounting Sources Entry or List panels.

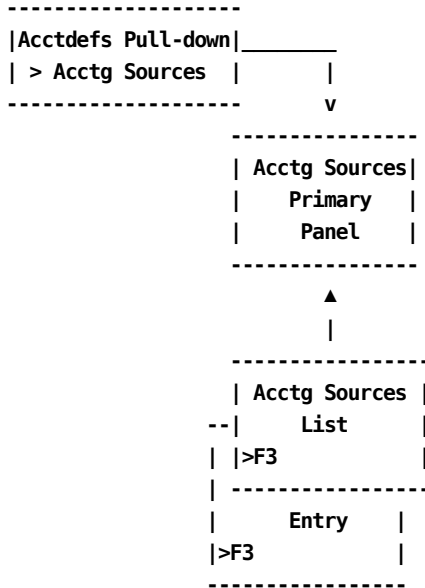

**Input**

The following prompts let you specify information that takes you to other panels where you can browse or enter information relating to Accounting Sources.

**ORD Type**

The three-character name of an ORD whose sources you want to define.

**Structure**

An organizational structure name within the hierarchy of your organization. For example, division, department, and so forth.

**Note:** Entering % and pressing F11 results in a display of all rows of the ACCSR TAB.

**Pathways**

**F2**

**(Create)** Takes you to Accounting Sources Entry Panel.

**F11**

**(Browse)** Takes you to Accounting Sources List Panel.

## Accounting Sources List Panel

The Accounting Sources List panel provides you with a list of all currently defined ORDs and structures meeting the search criteria specified on the Accounting Sources primary panel. The search criteria are redisplayed as protected display fields.

```

USERID                               CA PMA Chargeback                MM/DD/YY HH:MM:SS
---  Acctdefs  Cbdefs  Query  Data  Period  Options  Exit  Help
+-- CBASRCL --- Accounting Sources List -----+
      Panel  Exit  Help
      -----
      Select accounting structure name. Then Enter.
      ORD Type . : MBJ                Version   : ABCD
      Structure : %_____            DM Version : PROD
      More: - + _____ Row 0001 of 0003
      ORD  Structure
      - MBJ DIVISION
      - MBJ DEPARTMENT
      - MBJ GROUP-ID
      -----
      Enter  F7=Bkwd  F8=Fwd  F11=Expand
+-----+

Command ==> _____
F1=Help  F3=Exit  F4=Prompt  F9=Command  F10=Action Bar  F12=Cancel  PA1=Susp
    
```

### Access

The Accounting Sources List panel appears when one of these events occurs:

- You press **F11** (Browse) on the Accounting Sources primary panel shown on page Accounting Sources Primary Panel.
- You return to this panel using **F3** from the Accounting Sources Expanded List panel.

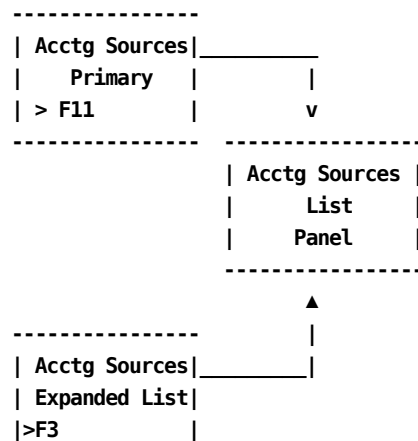

-----

### **Scrolling**

F7 and F8 let you scroll backward and forward through the Structure selection list. You can also use the scroll bar, as explained on page Sample List Panel, to move through the list.

### **Pathways**

#### **Enter**

By positioning the cursor next to an item and pressing **Enter**, you can go to the Accounting Sources Entry panel to examine and optionally update the selected item.

#### **F11**

##### **(Expand)**

Gives you an **expanded** (eight-line display) view of the Accounting Sources List panel.

## Expanded Sources List Panel

The following panel appears when you press **F11 (Expand)** on the Accounting Sources List panel. The only difference between the two panels is the ORD Type, Version, Structure and DM Version display fields are not shown. This allows you to view more information on a single panel. The Expanded List panel functions in the same way as the panel from which it was called.

```

USERID                               CA PMA Chargeback                MM/DD/YY HH:MM:SS
---  Acctdefs  Cbdefs  Query  Data  Period  Options  Exit  Help
+-- CBASRCX ---- Expanded Sources List -----+
      Panel  Exit  Help
      -----
      Select accounting structure name. Then Enter.
      More: - + ____ Row 0001 of 0001
      ORD Structure
      _ MBJ DEPARTMENT
      -
      -
      -
      -
      -
      -
      Enter  F7=Bkwd  F8=Fwd
+-----+

Command ==> _____
F1=Help  F3=Exit  F4=Prompt  F9=Command  F10=Action Bar  F12=Cancel  PA1=Susp
    
```

## Accounting Sources Entry Panel

The Accounting Sources Entry panel lets you examine, define, and optionally update detail information for an accounting structure. It displays information meeting the ORD Type and Structure search criteria you specified on the Accounting Sources primary panel. This panel gives you a true representation of the detail in the ACCSRTAB table.

**Note:** You **must** define sources for every ORD Type that CA PMA Chargeback uses.

The Accounting Sources Entry panel, provided on the next page, shows how to provide the definition for an accounting structure called Division **without** using the Lookup Table option. You can define up to three field names. Note that each structure can be comprised of up to three source fields/subfields. In this example, Division is composed of three fields: JOBNAME, ACCTCODE, and USER-INFO. It shows the sources for the MBI ORD (A):

- The first four characters of the JOBNAME field concatenated with
- The first eight characters of ACCTCODE field concatenated with
- The first four characters of USER-INFO field

The following diagram shows you STRUCTURE1 (DIVISION).

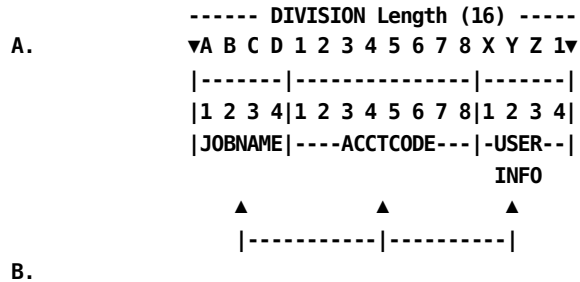

A.

When ORD records are processed, the values contained within these fields are displayed for this structure (DIVISION).

B.

These are the ORD field names.

**Caution** The **sum** of the Length column contained on the Accounting Sources Entry panel **must not** exceed the length of the structure as defined on the Accounting Structure panel shown on Accounting Structure Panel.

```

USERID          CA PMA Chargeback          MM/DD/YY HH:MM:SS
---            +---+ CBASRCE --- Accounting Sources Entry -----+
|              | Panel Exit Help |
|              |-----|
|              | Type information. Then select an action. |
|              |
|              | Version . :          Acct Version : PROD |
|              | ORD Type . : MBJ |
|              | Structure : DIVISION |
|              |
|              | Lookup Table _____ |
|              |
|              | ORD Field Name   St Length |
|              | JOBNAME_____   01  04 |
|              | ACCTCODE_____   01  08 |
|              | USER-INFO_____   01  04 |
|              |
|              | F5=Save  F6=Delete  F11=Lookup |
+-----+-----+
Command ==> _____
F1=Help  F3=Exit  F4=Prompt  F9=Command  F10=Action Bar  F12=Cancel  PA1=Susp
    
```

The following is a description of the Accounting Sources Entry panel.

**Access**

The Accounting Sources Entry panel appears when one of these events occurs:

- You press **F2** (Create) on the primary panel.
- You make a selection on the Accounting Sources List or Expanded List panel.
- You return from the Lookup Table entry panel by pressing **F3**.

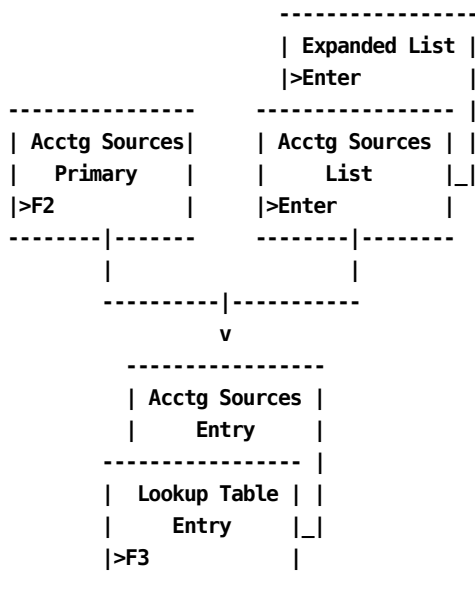

### Input

The following Accounting Sources Entry panel fields (C-F above) are available for input:

#### Lookup Table (optional)

This optional feature is used to identify the specific entities within an Accounting Structure. It allows you to define a meaningful name for each entity. Enter a name (up to eight alphanumeric characters) that is associated with the structure you are defining. You **are not** restricted to the ORD Type from which the table was invoked. A discussion of the Lookup Table option is provided in Creating a Lookup Table.

**Note:** To view a list of defined Lookup Table names, press F4 (Prompt) while the cursor is positioned at the Lookup Table field.

#### ORD Field

##### Name

Defines the ORD Field Name that contains this structure's value.

##### St

Specifies which column in this field to **start** from when obtaining structure information.

##### Length

Specifies the **length** or number of columns to read from the start column when obtaining information to identify this structure.

#### Actions

##### F5=Save

Lets you add or update rows in the ACCSRTAB table.

##### F6=Delete

Lets you delete rows from the ACCSRTAB table.

##### F11=Lookup

Takes you to the Lookup Table entry panel (section Creating a Lookup Table ).

**Note:** You should **save** this panel using F5 **before** proceeding to the Lookup Table entry panel.

##### F4=Prompt

To view a list of defined Lookup Table names, press F4 (Prompt) while the cursor is positioned at the Lookup Table field.

## Example 1: Defining Accounting Sources Without a Lookup Table

In this example, we are telling CA PMA Chargeback to:

- Create a field called DIVISION for the MBJ (Batch Job) ORD
- Its sources should be:
  - The first four characters of the JOBNAME, concatenated with
  - The first eight characters of the ACCTCODE field, concatenated with
  - The first four characters of the USER-INFO field

```

|----- DIVISION Length (16) -----|
▼A B C D 1 2 3 4 5 6 7 8 X Y Z 1▼
|-----|-----|-----|
|1 2 3 4|1 2 3 4 5 6 7 8|1 2 3 4|
-JOBNAME-----ACCTCODE-----USER---
                               INFO
    
```

**Note:** When you perform a query or print an invoice, this structure will be displayed as: DIVISION: ABCD12345678XYZ1

```

USERID          CA PMA Chargeback          MM/DD/YY HH:MM:SS
---            +-----+
Acctdefs  Cbdefs  Query  Data  Period  Options  Exit  Help
+-- CBASRCE --- Accounting Sources Entry -----+
|
| Panel Exit Help
|-----+
| Type information. Then select an action.
|
| Version . :                               Acct Version : PROD
| ORD Type . : MBJ
| Structure : DIVISION
|
| Lookup Table _____
|
| ORD Field Name   St  Length
| JOBNAME_____  01  04
| ACCTCODE_____  01  08
| USER-INFO_____ 01  04
|
| F5=Save  F6=Delete  F11=Lookup
+-----+
Command ==> _____
F1=Help  F3=Exit  F4=Prompt  F9=Command  F10=Action Bar  F12=Cancel  PA1=Susp
    
```

This processing takes place at Detail function time for each ORD record.

The ACCSRTAB table is used to generate the required code to perform this task. The data entered is validated to ensure that the fields used in the creation of the *construct* are valid and exist within the ORD definition.

## Example 2: Defining Accounting Sources Using a Lookup Table

In this example, we are telling CA PMA Chargeback to:

- Create a field called DIVISION for the MBJ (Batch Job) ORD
- Its sources should be:
  - The first four characters of the JOBNAME, concatenated with
  - The first eight characters of the ACCTCODE field, concatenated with
  - The first four characters of the USER-INFO field

```

|----- DIVISION Length (16) ----|
▼A B C D 1 2 3 4 5 6 7 8 X Y Z 1▼
|-----|-----|-----|
|1 2 3 4|1 2 3 4 5 6 7 8|1 2 3 4|
-JOBNAME-----ACCTCODE-----USER---
                               INFO
    
```

- Create a Lookup Table named DIVTAB

```

USERID          CA PMA Chargeback          MM/DD/YY HH:MM:SS
---            -
Acctdefs Cbdefs Query Data Period Options Exit Help
+-- CBASRCE --- Accounting Sources Entry -----+
|
| Panel Exit Help
|-----+
|
| Type information. Then select an action.
|
| Version . :                               Acct Version : PROD
| ORD Type . : MBJ
| Structure : DIVISION
|
| Lookup Table DIVTAB
| ORD Field Name   St Length
|
| JOBNAME_____  01  04
| ACCTCODE_____  01  08
| USER-INFO_____ 01  04
|
| F5=Save  F6=Delete  F11=Lookup
+-----+
Command ==>
F1=Help  F3=Exit  F4=Prompt  F9=Command  F10=Action Bar  F12=Cancel  PA1=Susp
    
```

Proceed to the discussion of the Accounting Sources Lookup panel presented on the next page.

## Creating a Lookup Table

The Lookup Table is an optional feature. It is used to name specific entities within an accounting structure and return a meaningful name for each entity you define. For example, an accounting structure's entities might be composed of entries that look like:

```
AA0000
ZZ9999
--|_|
| |
| --The fourth through seventh positions of ACCTCODE
--The first two positions of JOBNAME
```

Most likely very few people in your organization would be able to identify specific entities using the above codes. However, by using the Lookup Table, you can assign a meaningful name to the above structure's entities (for example, Accounting for AA0000 and Operations for ZZ9999).

**Note:** Once you define a Lookup Table, you are **not restricted** to the ORD type from which the table was invoked. However, the return value (the number of characters) and From and To range length **must** be consistent. There is **no limit** on the number of Lookup Table entries you can create.

The following is a sample Accounting Sources Lookup panel. The protected display fields, preceded by colons (:), display information you entered on the Accounting Sources Entry panel. A description of the Accounting Sources Lookup panel is provided next.

```

USERID          CA PMA Chargeback          MM/DD/YY HH:MM:SS
--  Acctdefs  Cbdefs  Query  Data  Period  Options  Exit  Help
+-- CBASRCU ----- Accounting Sources Lookup -----+
|   Panel  Exit  Help
|-----+
|   Type information. Then select an action.
|
|   Version . . . :                               DM Version : PROD
|   Lookup table : DIVTAB
|
|   Cnd From range      More: - + ____  Row 0000 of 0000
|                       To range      Return value
|
|   _____  _____  _____
|   _____  _____  _____
|   _____  _____  _____
|   _____  _____  _____
|
|   F5=Save  F6=Delete  F7=Bkwd  F8=Fwd
+-----+

Command ==> _____
F1=Help  F3=Exit  F4=Prompt  F9=Command  F10=Action Bar  F12=Cancel  PA1=Susp
    
```

**Note:** The first time the Accounting Sources Lookup panel appears, you are in **insert** mode; no lines appear under the Cmd column, the scroll bar does not show a row count, and the only active panel function keys are F2, F5, and F11. When you press F5 (Save), you receive a message telling you the **insert** is successful. At this point, you are in **update** mode. The panel scroll bar provides a row count, the Cmd column is active (lines appear under the column) and **all** panel function keys are active. Pressing F5 (Save) displays a message telling you the **update** is successful.

**Access**

The Accounting Sources Lookup Table panel appears when you press **F11** (Lookup) on the Accounting Sources Entry panel.

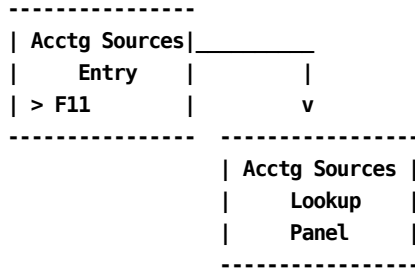

**Input**

The following Accounting Sources Lookup panel fields are available for input:

**Cmd**

This column is used to specify commands. Valid commands include:

D Deletes individual rows from the table.

I Inserts row(s) into the table using the Accounting Sources Insert (CBASRCI) pop-up window. Refer to page Sample Entry Panel Insert Pop-Up Window for information on how to use the Insert window.

**From range**

Enter the starting value that defines an accounting entity for the structure named in the Structure display field at the top of the Accounting Sources Entry panel. Examples are provided on the next page.

Note that you can use the SQL wildcard % in the From range. If you do so, the To range **must** be blank. For example, to check for the occurrence of the value **A** in the third position of a string, specify: %%A%. Because the **first** match is used, you should order your entries with wildcards first, followed by explicit (full) values in the From range. If a record does not match any of the entries, then the **last** item defined in the Lookup Table is used.

**To range**

Enter the ending value to complete the range defining the entity. Examples are provided on the next page.

**Return value**

Enter the name (up to 16 alphanumeric characters) you want **stored** in the database. This name is also available for display when doing queries and printing invoices; it cannot be greater than the accounting structure length.

**Caution** If CA PMA Chargeback encounters a record that has **not** been defined in the Lookup Table, it defaults to the **last** entry's return value.

**Note:** The sequence of your entries is important **only** if you have overlapping sources. In the event of overlapping ranges, CA PMA Chargeback stops its search at the first match. For example, if you specify:

From range	To range	Return value
AA0001	AZ0001	New York
AB9999	AC0001	New Jersey

You would never see a return value of New Jersey, since the search stops when it encounters the first true condition.

**Tip**

Try adding % as the last entry and assign it a value of *other* or *undefined*.

From range	To range	Return value
%		Other

**Scrolling**

F7 and F8 let you scroll backward and forward through the Structure selection list. You can also use the scroll bar to move through the list.

**Actions**

**F5=Save**

Saves any data you entered.

**F6=Delete**

Deletes the entire Lookup Table. To delete an entry, type D on that entry and press enter.

## Example 1: Defining Entities for a Division

Using the Accounting Sources Lookup panel below, we are defining four distinct entities for MBJ ORD Types within a structure called Division. In Example 2 in Example 2: Defining Accounting Sources Using a Lookup Table, we indicated that our accounting sources were:

ORD Field Name	St	Length
MBJ-JOBNAME	01	04
MBJ-ACCTCODE	01	08
MBJ-USER-INFO	01	04

Therefore, our entries look like those shown on the panel below.

```

-----
▼A B C D 1 2 3 4 1 2 3 8 X Y Z 1▼
|-----|-----|-----
|1 2 3 4|1 2 3 4 5 6 7 8|1 2 3 4|
-JOBNAME|----ACCTCODE---|-USER---
                               INFO
    
```

USERID	CA PMA Chargeback	MM/DD/YY HH:MM:SS
---	Acctdefs    Cbdefs    Query    Data    Period    Options    Exit    Help	
	+- CBASRCU    ----- Accounting Sources Lookup -----+	
	Panel    Exit    Help	
-----		
Type information. Then select an action.		
Version . . . :		DM Version : PROD
Lookup table : DIVTAB		
Cmd From range		More: - + ____    Row 0001 of 0004
To range		Return value
_	ABCD12345678XYZ1	CDEF12345678XYZ1    GARDEN CITY____
_	DBCD12345678XYZ1	EDEF12345678XYZ1    DALLAS____
_	GBCD12345678XYZ1	IDEF12345678XYZ1    PRINCETON____
_	JBCD12345678XYZ1	PDEF12345678XYZ1    RESTON____
-----		
F5=Save    F6=Delete    F7=Bkwd    F8=Fwd		
+-----+		
Command ==> _____		
F1=Help    F3=Exit    F4=Prompt    F9=Command    F10=Action Bar    F12=Cancel    PA1=Susp		

## Example 2: Defining Entities for a Department

Using the Accounting Sources Lookup panel below, we are defining six distinct entities for MBJ ORD Type within a structure called Department. Our Accounting Sources are:

ORD Field Name	St	Length
MBJ-JOBNAME	02	02
MBJ-ACCTCODE	04	04

DEPARTMENT Structure Length = 16

Therefore, our entries look like this: AA9999, where AA is the JOBNAME and 9999 represents the ACCTCODE value.

```

USERID          CA PMA Chargeback          MM/DD/YY HH:MM:SS
--            +---+ CBASRCU ----- Accounting Sources Lookup -----+
|             Panel Exit Help
|             -----
|             Type information. Then select an action.
|             Version . . . :                      DM Version : PROD
|             Lookup table : DEPTAB
|             Cmd From range          More: - + _____ Row 0001 of 0005
|             To range                Return value
|             AA0001_____ AA0010_____ DEVELOPMENT_____
|             AB0001_____ AB0020_____ QA_____
|             AC0001_____ AC0005_____ SUPPORT_____
|             BB0004_____ BB0009_____ ACCOUNTS PAYABLE
|             BB0100_____ BB0300_____ RECEIPTS_____
|             F5=Save  F6=Delete  F7=Bkwd  F8=Fwd
+-----+
Command ==>
F1=Help  F3=Exit  F4=Prompt  F9=Command  F10=Action Bar  F12=Cancel  PA1=Susp
    
```

To enter the sixth range, you must press F5 to save the entries; then, scroll the screen forward using F8.

```

USERID                               CA PMA Chargeback                               MM/DD/YY HH:MM:SS
---  Acctdefs  Cbdefs  Query  Data  Period  Options  Exit  Help
+-- CBASRCU ----- Accounting Sources Lookup -----+
|   Panel  Exit  Help
|-----+
|   Type information. Then select an action.
|
|   Version . . . :                               DM Version : PROD
|   Lookup table : DEPTAB
|
|   Cmd From range          More: - + ____   Row 0006 of 0006
|                               To range      Return value
|   _ CC0000_____   DE0020_____   EASTERN SALES__
|   - _____   _____   _____
|   - _____   _____   _____
|   - _____   _____   _____
|
|   F5=Save  F6=Delete  F7=Bkwd  F8=Fwd
+-----+
Command ==> _____
F1=Help  F3=Exit  F4=Prompt  F9=Command  F10=Action Bar  F12=Cancel  PA1=Susp
    
```

**Note:** If our DEPARTMENT structure length had been defined as having a length of 10 on the Accounting Structures panel and you entered a Return Value that exceeded 10 characters, you would receive a message telling you that the entity's Return Value **exceeds** the length of the structure. In this case, you must provide a new Return Value with a character count that is less than or equal to the structure's length.

**Remember:** The return value can **never** be greater than the structure length defined on the Accounting Structure panel.

## Defining Accounting Periods

In order to maintain fixed periods across all ORD input records, an Accounting Period Table (PERTAB) is maintained to specify the End Date and Time for a given period. The PERTAB is used to determine the period to which a given detail record is allocated.

The contents of the protected display field Version, is determined by information you specify using the Options facility. See Versions for further details.

The following is a sample Accounting Periods entry panel.

```

USERID                               CA PMA Chargeback           MM/DD/YY HH:MM:SS
---  Acctdefs  Cbdefs  Query  Data  Period  Options  Exit  Help
+-- CBAPERE - Accounting Periods -----+
|                                     |
|   Panel  Exit  Help                |
|-----|
|   Type information and save.        |
|                                     |
|   Version :                        |
|                                     |
|           More: - + ____  Row 0001 of 0005 |
|           End              End        |
|   Cmd  Period  MM/DD/YYYY  HH:MM      |
|-----|-----|-----|-----|
|   -    001    01/31/1990   24:00      |
|   -    002    02/28/1990   24:00      |
|   -    003    03/31/1990   24:00      |
|   -    004    04/30/1990   24:00      |
|   -    005    05/30/1990   24:00      |
|                                     |
|   F5=Save  F7=Bkwd  F8=Fwd          |
+-----+
Command ==> _____
F1=Help  F3=Exit  F4=Prompt  F9=Command  F10=Action Bar  F12=Cancel  PA1=Susp
    
```

**Note:** The first time this panel appears, you are in **insert** mode; no lines appear under the Cmd column, the scroll bar does not show a row count, and the only active panel function key is F5. When you press F5 (Save), a message appears telling you the **insert** is successful. At this point, you are in **update** mode. The panel scroll bar provides a row count, the Cmd column is active (lines appear under the column) and **all** panel function keys are active. Pressing F5 (Save) displays a message telling you the **update** is successful.

### Access

The Accounting Periods panel appears when one of these events occurs:

- You type AP in the fast path area of the Primary Panel's action bar.
- You select Acctdefs on the Primary Panel's action bar and then choose Period Tables on the Acctdefs pull-down.

-----

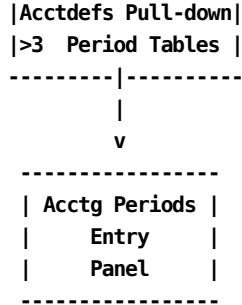

**Input**

The following Accounting Periods entry panel fields are available for input:

**Cmd**

Used to specify commands. The only valid command for this panel is:

D Deletes individual rows from the table.

**Note:** You **cannot** delete a period once it has been closed.

**Period**

Contains the period identifier, a number, that is a key to the CCCTAB table.

**Note:** For validation, there must be no overlap between periods, and the date/times **must** be in sequence. Also, a period cannot be changed if it is the *current* period or if it has passed. This ensures that the contents of the CCCTAB are accurate.

**End MM/DD/YYYY**

Contains the ending date of the specified period. Its format is mm/dd/yyyy. You cannot save this data unless you provide an End Time for each period.

**End HH:MM**

Contains the ending time for the specified period. You **must** provide an End Time: no default is provided.

**Actions**

**F5=Save**

Lets you add and update rows in the table.

**F7=Bkwd**

Lets you scroll backwards through the table.

**F8=Fwd**

Lets you scroll forward through the table.

# Chapter 4: Defining Charges

---

## Overview

With CA PMA Chargeback you can create both simple and complex charge algorithms to charge for resource consumption. CA PMA Chargeback gives you total **flexibility** and **control** over this process. The Cbdefs options discussed in this chapter are invoked when you select **Cbdefs** from the CA PMA Chargeback Primary Panel's action bar. The Cbdefs pull-down presents you with nine choices. Charge definition uses the following choices:

- 1 Charge Elements
- 2 Charge Units (U)
- 3 Qualifiers
- 4 Normalizers
- 5 Modifiers
- 6 Split Job Charges
- 7 Shift Chop (B)

While all of the Cbdefs choices are available to you, the following choices are **not** discussed in this chapter: Choices 8 and 9 are used in performing adjustments and are discussed in Chapter 5.

**Note:** When reviewing our examples, please keep in mind that there are many different ways in which you can proceed. We are showing you just a few of the possibilities.

On the next page is a summary of the choices that are available to you for defining your rate charges.

**Cbdefs Pull-Down**

USERID	CA PMA Chargeback	MM/DD/YY HH:MM:SS
__ Acctdefs Cbdefs Query Data Period Options Exit Help		
<div style="border: 1px dashed black; padding: 5px;"> <p style="text-align: center;">CB Definitions</p> <p>_ 1. Charge Elements</p> <p>2. Charge Units (U)</p> <p>3. Qualifiers</p> <p>4. Normalizer</p> <p>5. Modifiers</p> <p>6. Split Job Charges</p> <p>7. Shift Chop (B)</p> <p>8. Cost Recovery (T)</p> <p>9. Overhead Distribution</p> <hr style="border-top: 1px dashed black;"/> <p>F12=Cancel</p> </div>		<p>A 1-character field that allows you to make a selection using a mnemonic that can be either a number or the first letter of an action. Notice that when actions have duplicate first letters, you can use either the number or the letter provided in the parentheses.</p> <p>You can also make your selection by tabbing the cursor next to the action you want to perform and pressing Enter.</p>
<p>Command ==&gt; _____</p> <p>F1=Help F3=Exit F4=Prompt F9=Command F10=Action Bar F12=Cancel PA1=Susp</p>		

The following choices are discussed in this chapter:

**1. Charge Elements**

Allow you to define the algorithms that are used to calculate your charges. This includes simple, complex, and normalized charge unit definitions, as well as simple and conditional rate definitions.

**2. Charge Units**

Allow you to define a user-defined charge unit that is a computed item.

**3. Qualifiers**

Provide you with a mechanism for qualifying charge units, normalizers, and modifiers.

**4. Normalizers**

Provide you with a mechanism for weighting the value of a charge unit.

**5. Modifiers**

Enable you to modify charges globally by adjusting charges via a user-defined percentage or applying a fixed surcharge or discount.

**6. Split Job Charges**

Give you the ability to split and distribute charges calculated for a specific accounting entity across multiple accounting entities.

**7. Shift Chop**

Provides you with the option of splitting ORD records that span user-defined shifts, ensuring equitable charging for long running tasks.

# Defining Charge Elements

The Charge Element definition is the most complex of the Cbdefs functions. This is because it accesses many behind-the-scene tables for inserting, updating, and validating data. The processing flow is as follows:

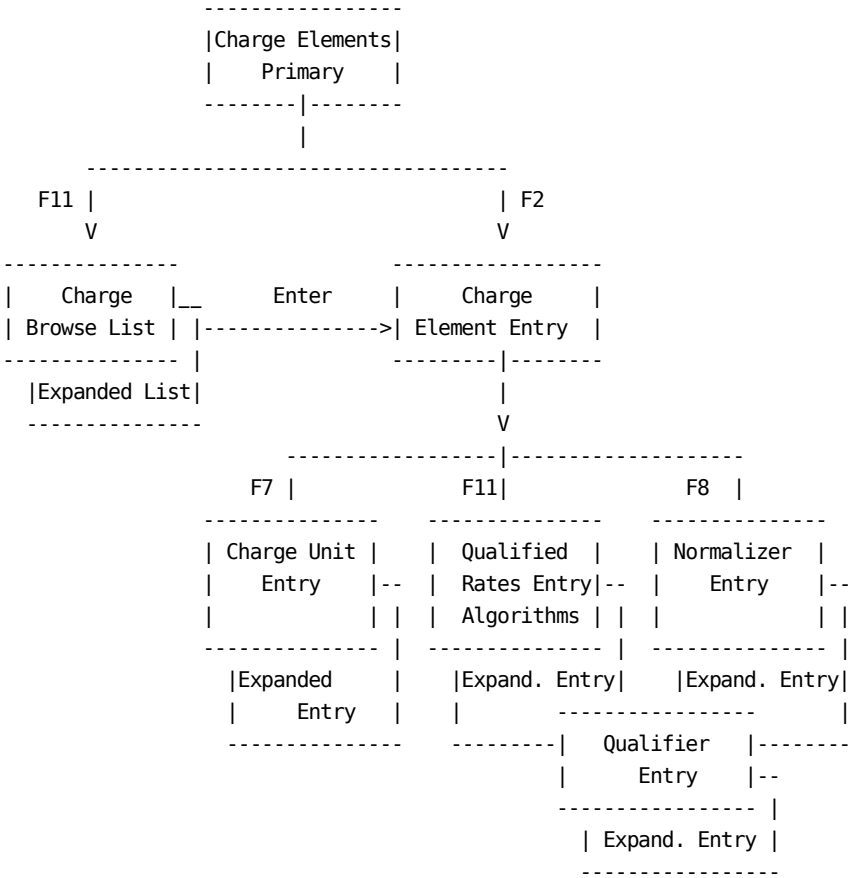

It is helpful to keep the following points in mind:

- A Charge Element is always associated with a Charge Unit
- Charge Elements own algorithms
  - Qualifiers are then associated with an algorithm
  - A Normalizer is directly associated with the Charge Element, and its factor is applied to the **calculated units**

The following examples and sample panels help you understand these concepts.

## The Chargeback Algorithm

The chargeback algorithms used by CA PMA Chargeback are defined by Version and ORD Type, which are in turn defined by your Chargeback Administrator. An algorithm is a formula used to calculate a charge. Each algorithm is associated or *owned* by a charge element. All calculations start with the *charge unit* definition. In its simplest form, the chargeback algorithm is:

```
          Charge      Charge
          Unit * Rate = Element
|         |         |
|         |         --User-defined field that holds the
|         |         result of the calculation
|         |
|         --Can be either simple or conditional
|
--Can be simple or complex
```

where:

### Charge Unit

Defines a chargeable resource. It can be any quantitative field. A charge unit can be:

- **Simple:** An existing ORD Element (field) contained within an ORD. That is, a numeric element from the incoming ORD record used in the chargeback algorithm. Any quantitative field in the incoming ORD record can be designated as a charge unit, and hence a chargeable resource.
- **Complex:** The calculated result of two or more existing elements (fields) defined within an ORD that is identified by a user-defined name and prefixed by @. Complex Units or an existing field and a constant are defined on the Charge Units Entry panel shown in Charge Units Entry Panel.

Charge units, both simple and complex, can also be **normalized**. That is, have a weighting factor applied that serves as a charge unit adjustment factor when a conditional test is applied that results in a true or false condition.

Normalization factors can be entered via the Charge Elements Entry Panel using F8 which takes you to the Normalizer Entry panel shown in Normalizer Entry Panel, or by selecting the Normalizers option on the Cbdefs pull-down and following the pathway to the Normalizer Entry panel shown in Normalizer Entry Panel. A normalizer's qualifiers are entered using the Qualifier Entry panel shown in Qualifier Entry Panel.

### Rate

A user-defined **charge** per unit. Rates can be:

- **Simple:** A constant (the default rate)
- **Conditional:** When different rates are applied to a unit based on its qualifier (a true or false condition based on the contents or range of a unit)

### Charge Element

A user-defined element (chargeable resource) that holds the **result** of a chargeback algorithm (the charge). A charge element is always associated with a charge unit.

### Calculation Logic

In the following section you see numerous examples of chargeback algorithms. However, it is critical that you understand the logic.

**Note:** As you can see from the examples below, you must present data to CA PMA Chargeback using linear or left-to-right order. This is because CA PMA Chargeback performs calculations in **the order they are presented**. That is:

- One row at a time
- From left to right
- From top to bottom

$(2 * 3) + 6 / 6 - 1$

Since CA PMA Chargeback performs calculations in the order they are presented and does not permit the use of parenthetical expressions (they are implied), you must present the algorithm in the sequence you want the calculations performed:

More: - + ____ Row 0001 of 0003						Operation	Result
Cmd	ORD	Field/@Unit	Aop	Field/Constant	Aop		
-	2		*	3	+	6 +	
-	6		/	6	-	6 + 1	7
-	1		-			7 - 1	6

More: - + ____ Row 0001 of 0004						Operation	Result
Cmd	ORD	Field/@Unit	Aop	Field/Constant	Aop		
-	2		*	3	+	6 +	
-	6		-		/	6	12
-	6		-		-	12 / 6	2
-	1		-			2 - 1	1

## Extended Charging Example

On the following pages we show you how to perform extended charging. We start with simple definitions and make them increasingly more complex. When you complete this chapter, you will know how to create a charge element with a normalized complex unit and conditional rate. A flow of this process is provided below. You may find it helpful to refer to it occasionally as we move through the different steps in the process. Remember, you can achieve the same results in many ways. We are only showing you one way.

```

-----
| Charge Element          |
|-----|
| Charge Element . CPU-CHARGE |
| Unit . . . . . @CPU-TIME |
| Minimum Charge . 0.50 |
|-----|-----
|
|-----|-----
|
|-----|-----
| Complex Unit          | Qualified Rates |
|-----|-----|
| Unit . . . . @CPU-TIME| @SHIFT1 . . 0.055 |
| TCB-TIME * '.5' + | @SHIFT2 . . 0.040 |
| SRB-TIME * '.5' | @SHIFT3 . . 0.026 |
|-----|-----|
|
|-----|-----|
| Normalizers          | Rate Qualifiers |-----| |
|---|---|---|---|
| Normalizer . . SYSTEM | Qualifier . . . @SHIFT1 |
| @CPUIDA . . 100 | | @SHIFT2 |
| @CPUIOB . . 530.8 | | START-TIME >= '0800' and | @SHIFT3 |
| | | START-TIME < '1600' |
|-----|-----|-----|
|
|-----|-----|
| Normalizer Qualifiers |-----|
|-----|-----|
| Qualifier . . @CPUIDA |
| | @CPUIDB |
| CPU ID = 'A' |
| |
|-----|-----|
|-----|-----

```

In this example we:

- Create a charge element: CPU-CHARGE.

- Define a complex charge unit: @CPU-TIME.
- Name a normalizer (SYSTEM) and assign weighting factors.
- Define qualifiers for the normalizer (SYSTEM). These qualifiers establish the tests that determine when and if the normalizer is applied.

For example, assume you have two CPUs with different processing speeds (CPUA and CPUB). You want to ensure that users' charges are equitable regardless of which CPU performs the work. All you need to do is apply a weighting factor that adjusts the charge unit calculation to allow for the difference in processing speed **before** rates are applied. The appropriate weighting factor (normalizer) is applied when the following qualifier tests are applied: If the CPU ID = A, multiply the unit by 100.00; if CPU ID = B, multiply the unit by 530.8.

- Establish conditional (qualified) rates based on rate qualifiers. Conditional Rates mean that the actual charge rate is determined by a set of user-defined conditions. For example, the time of day a resource is used. These conditions are specified as qualifiers and are defined in the next step.
- Define qualifiers that determine the rate used in calculating the charge element: CPU-CHARGE. The algorithm looks like this:

$$\begin{array}{ccccccc}
 \text{Complex} & & & & & & \text{(RESULT)} \\
 \text{Unit} & * & \text{Normalizer} & * & \text{Condit'l Rate} & = & \text{Charge Element} \\
 | & & & & & & \\
 \text{--Normalized Unit--} & & & & & & 
 \end{array}$$

### Data Entry Conventions

- When specifying constants in qualifiers, they **must** be enclosed in single quotes. For example, priority '9' or START-TIME =< '0800'. Otherwise CA PMA Chargeback treats them as ORD element names.
- The following entries must be prefixed with the @ symbol:
  - A user-defined complex unit. For example, CPU-TIME must be entered as @CPU-TIME. This allows CA PMA Chargeback to differentiate between user-defined charge unit names and charge unit names having a direct one-to-one relationship with ORDs available to the DataManager application.
  - Qualifier names, such as SHIFT1, SHIFT2 must also have the @ prefix: @SHIFT1, @SHIFT2.

# Charge Elements Panels

## Charge Elements Primary Panel

You use this panel to specify a *charge element* or group of elements you want to define, browse or modify that are associated with an ORD Type. The panel below shows how to indicate you want to view all charge elements for ORD record type MBJ.

**Note:** Protected display field areas are preceded by a colon (:).

```

USERID                               CA PMA Chargeback                MM/DD/YY HH:MM:SS
--  Acctdefs  Cbdefs  Query Data  Period  Options  Exit  Help
+--- CBCELMF ----- Charge Elements -----+
|      Panel  Exit  Help                       |
+-----+
|      Type information. Then select an action.  |
|      Version . . . : PROD                      |
|      ORD Type . . . : MBJ                      |
|      Charge Element . %                       |
|      F2=Create  F11=Browse                    |
+-----+

This panel associates an ORD record type, as defined by
the CA PMA Chargeback DB Administrator, with
charge elements.

Command ==> _____
F1=Help  F3=Exit  F4=Prompt  F9=Command  F10=Action Bar  F12=Cancel  PA1=Susp
    
```

Next is a description of the Charge Elements primary panel.

### Access

The Charge Elements primary panel appears when one of these events occurs:

- You type CC in the fast path area of the Primary Panel's action bar.
- You select Cbdefs from the action bar and then choose Charge Elements on the Cbdefs pull-down.
- You return from the Charge Elements List or Entry panel.

```

-----
|Cbdefs Pull-down|-----|
|> Charge Elem. |         v
-----
| Charge Elem. |
| Primary     |
    
```

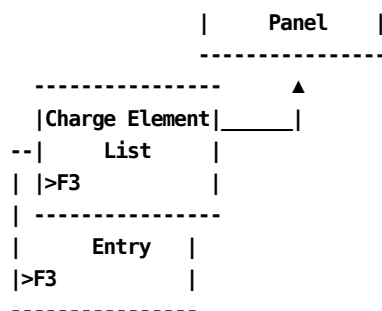

### Input

The following Charge Elements primary panel fields are available for input:

#### ORD Type

The three-character name of the ORD Type for which you want to define a charge.

When using F11=Browse: if you do not know the ORD Type name, you can enter the SQL wildcard character %. This provides you with a list of all ORD Types meeting the Charge Element you specify in the next field. Or you can enter a % at both the ORD Type and Charge Element prompts and get a list of everything.

**Note:** If you enter an ORD Type that is not currently defined to the CA PMA Chargeback database, an informational message appears. You cannot continue with any definition of this ORD Type until it has been defined to the specific version of DataManager against which CA PMA Chargeback is validating its data. Therefore, you will need to speak to the DataManager and CA PMA Chargeback Administrators to arrange for the ORD Type definition.

#### Charge Element

The name of the charge element (up to 16 alphanumeric characters) you want to create, view, or modify. When creating charge elements, try to give them meaningful or descriptive names.

### Pathways

#### F2

**(Create)** takes you to the Charge Elements Entry panel shown in Charge Elements Entry Panel. However, if the specified Charge Element already exists, receive a message telling you so. You can then press F11 (Browse).

#### F11

**(Browse)** takes you to the Charge Elements List panel shown in Charge Elements List Panel. This panel gives you a list of all currently defined charge elements for the specified ORD Type.

## Charge Elements List Panel

The Charge Elements List panel displays a list of all currently defined charge elements meeting the criteria specified on the Charge Elements primary panel. The search criteria are redisplayed as protected display fields at the top of the panel.

```

USERID                                CA PMA Chargeback                MM/DD/YY HH:MM:SS
---  Acctdefs  Cbdefs  Query  Data  Period  Options  Exit  Help
+--- CBCELML ----- Charge Elements List -----+
      Panel  Exit  Help
-----+-----
      Select charge element name. Then Enter.

      Version . . . . : PROD
      ORD Type . . . . : MBJ
      Charge Element : %

                                More: - + ____ Row 0001 of 0003

      ORD Charge Element

      _ MBJ CPU-CHARGE
      _ MBJ DISK-CHARGE
      _ MBJ TAPE-CHARGE
      _

      Enter  F7=Bkwd  F8=Fwd  F11=Expand
-----+-----

Command ==>
F1=Help  F3=Exit  F4=Prompt  F9=Command  F10=Action Bar  F12=Cancel  PA1=Susp
    
```

The following is a description of the Charge Elements List panel.

### Access

The Charge Elements List panel appears when one of these events occurs:

- You press **F11** (Browse) on the Charge Elements primary panel shown in Charge Elements Primary Panel.
- You return from the Expanded Charge Elements List panel.

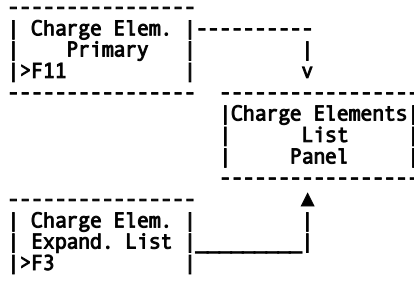

**Scrolling**

F7 and F8 let you scroll backward and forward through the Charge Element selection list. You can also use the scroll bar, as explained on page Sample List Panel, to move through the list.

**Pathways**

**Enter**

By placing the cursor next to the item you want to view and pressing **Enter**, you can go to the Charge Elements Entry panel (shown in Charge Elements Entry Panel) to examine and optionally update its contents.

**F11**

**(Expand)** Gives you an **expanded** (eight-line display) view of the Charge Elements List panel.

**Expanded Charge Elements List Panel**

The following panel appears when you press F11 (Expand) on the Charge Elements List panel shown in Charge Elements List Panel. The only difference between the two panels is the Version, ORD Type, and Charge Element protected fields are not displayed. This allows you to view more information on a single panel. The Expanded List panel functions in the same way as the List panel from which it was called.

```

USERID          CA PMA Chargeback          MM/DD/YY HH:MM:SS
--  Acctdefs  Cbdefs  Query Data Period  Options  Exit  Help
+-- CBCELMX ----- Charge Elements List -----+
|          Panel  Exit  Help
|-----+
| Select charge element name. Then Enter.
|
|          More: - + ____ Row 0001 of 0003
| ORD Charge Element
|
|  _ MBJ CPU-CHARGE
|  _ MBJ DISK-CHARGE
|  _ MBJ TAPE-CHARGE
|
|  _
|  _
|  _
|
|          Enter  F7=Bkwd  F8=Fwd
+-----+

Command ==>
F1=Help  F3=Exit  F4=Prompt  F9=Command  F10=Action Bar  F12=Cancel  PA1=Susp
    
```

## Charge Elements Entry Panel

The Charge Elements Entry panel is used to specify a **charge unit's** name and **default** rate. You can also assign maximum and minimum charges for the charge unit based on the calculated value of the charge element, as well as a normalizer.

```

USERID          CA PMA Chargeback          MM/DD/YY HH:MM:SS
--- Acctdefs  Cbdefs  Query  Data  Period  Options  Exit  Help
+-- CBCELME  ----- Charge Elements Entry -----+
|   Panel  Exit  Help  |
|-----|
|   Type information. Then select an action.   |
|   Version . . . : PROD                       |
|   ORD Type . . . : MBJ                       |
|   Charge Element : TAPE-MOUNT-CHARGE         |
|   Charge Unit   . . TAPE-MOUNT_____        |
|   Normalizer . . . _____                |
|   Default Rate . . 1.00000_____            |
|   Maximum Charge . _____                |
|   Minimum Charge . _____                |
|   F5=Save  F6=Delete  F7=Unit  F8=Norm  F11=Rate  |
+-----+

Command ==> _____
F1=Help  F3=Exit  F4=Prompt  F9=Command  F10=Action Bar  F12=Cancel  PA1=Susp
    
```

If you enter a Normalizer name that is not defined and press F5 (Save), you receive a message telling you to define the normalizer. You do this by pressing F8 (Norm). After saving the normalizer definition, you are returned to this panel. At this point you can either, proceed with the entry of other information or press F5 (Save).

**Note:**

- Charge, Rate and Unit precision is specified in the CAIKSPAR parameter file.
- Using \*ONE\* as the named charge unit allows you to charge a fixed rate for a resource, or create a surcharge. Refer to the example in Charging a Flat Rate.
- When performing zero-based accounting, it is critical that you create charge elements and assign a default rate of zero. Even though this results in a 0 charge, it ensures records are generated so that you can later adjust your charges. Remember, no CCCTAB records are generated unless you have defined charge elements.

The following is a description of the Charge Elements Entry panel.

**Access**

The Charge Elements Entry panel appears when one of these events occurs:

- You press **F2** (Create) on the Charge Elements primary panel.

- You make a selection on the Charge Elements List or Expanded List panel.
- You return from the Charge Elements List, Charge Units Entry, Normalizer, or Qualified Rate panels.

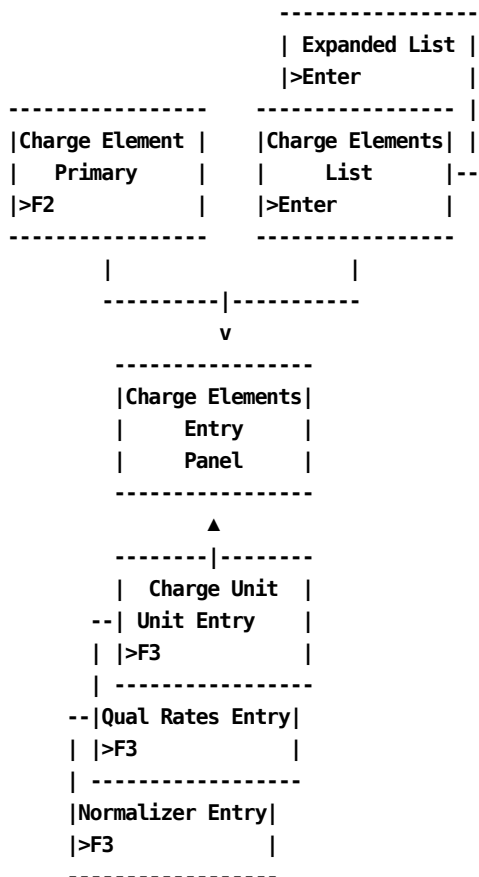

### Input

The following Charge Elements Entry panel fields are available for input:

#### Charge Unit (Required)

The unit name (up to 16 alphanumeric characters) of a numeric field from the incoming ORD record used in the chargeback algorithm or a complex charge unit name. A charge unit can be **either** simple (field from ORD), or complex (@CPU-TIME: a combination of fields from an ORD). Both types can be normalized.

**Note:** If you supply a *complex* Charge Unit name that is not defined, you are not able to save the data. A message appears telling you this. You must now define the named complex Charge Unit by pressing (F7 Unit). After defining the complex Charge Unit, you are returned to the Charge Elements Entry panel. You can now successfully save the data.

#### Normalizer

The name (up to 16 characters) of a weighting factor you want applied to a charge unit. You define normalizers using the Normalizer Entry panel in Normalizer Entry Panel.

**Note:** If you supply a normalizer name that is not defined, you are not able to save the data. A message appears telling you this. You must now define the named normalizer by pressing F8 (Norm). After defining the normalizer, you are returned to the Charge Elements Entry panel. You can now successfully save the data.

**Default Rate (Required)**

Can be any numeric, including negative numbers, zero, or all 9s. The default is 0.

Note 1 All 9s is a special condition. It tells CA PMA Chargeback that **no record** should be generated unless a conditional rate (qualified rate) is applied. For instance, you may have three qualified rates set up for an element that has a default rate of all 9s. If any of the qualified rates are used, a charge record is created and written out to the CCCTAB file. If all of the qualified rates are found to be false, the default rate of all 9s causes no record to be written out to the CCCTAB file.

You must specify the default rate with the correct decimal precision. If you do not know the precision to enter, press F4 (Prompt) with the cursor positioned at the Default Rate entry field. The decimal defined in the CAIKSPAR parameter file appear.

Note 2 The default rate can be used regardless of whether a rate is simple or conditional. However, if you are using conditional rates, you need to define them. You do this by pressing F11 (Rate), this takes you to the Qualified Rates Entry panel (discussed in Qualified Rates Entry Panel).

**Maximum Charge:**

The maximum charge that can be assessed for the **charge element**. If the computed charge is greater than or equal to the maximum charge, the maximum charge is applied.

**Minimum Charge:**

The minimum charge that can be assessed for the **charge element**. If the computed charge is less than or equal to the minimum charge, the minimum charge is applied.

**Actions**

**F5=Save**

Causes the contents of the panel to be saved to disk.

**F6=Delete**

Causes the record to be deleted.

**F7=Unit**

Takes you to the Charge Units Entry panel (section Charge Units Entry Panel). This key is only functional when a complex charge unit has been named or defined.

**F8=Norm**

Takes you to the Normalizer Entry panel (section Normalizer Entry Panel).

**F11=Rate**

Takes you to the Qualified Rates Entry panel (section Qualified Rates Entry Panel).

At various points throughout the online system there will be a need to reference Output Record Definition (ORD) fields, and to know what format these fields are in. The most notable cases are when you are creating charge elements, complex units, and qualifiers. By pressing PF4 while the cursor is on a field that may contain an ORD field name, the following choices panel is displayed:

USERID	CA	PMA	Chargeback	MM/DD/YY	HH:MM:SS
---	Acctdefs	Cbdefs	Query Data Period	Options	Exit Help
---	+- C+	-----+-----			
		CHOICES			
	Ty	ELEMENT	FORMAT	LENGTH	PREC
	Ve	*ONE*			
	OR	@TEST-LIST			
	Ch	ABSORPTION RATE	N	04	00
		ACTIVE TIME	R	08	05
	Ch	ADJUSTED RATE	N	06	02
	No	ALLOC DELAY TIME	R	08	05
	De	CARDS PUNCHED	N	06	00
	Ma	CARDS READ	N	06	00
	Mi	CONNECT CHARGE	N	05	02
		CONNECT TIME	R	08	05
		CORE ALLOCATED	N	04	00
	F	CORE USED	N	04	00
	+-	CPU INDEX	N	02	00
		-----+-----			
		+			
Command ==>					
F1=Help F3=Exit F4=Prompt F9=Command F10=Action Bar F12=Cancel PA1=Susp					

For all entries that have been retrieved from the ORD table the FORMAT, LENGTH, and PREC fields are filled in.

## Example 1: Creating a Simple Charge Algorithm

The following panel shows how to define a simple charge algorithm called DISK-IO-CHARGE using the basic chargeback algorithm:

**Simple Simple Charge**  
**Unit \* Rate = Element**

**DISK-IO \* .50 = DISK-IO-CHARGE**

### Simple Charge Format

```

USERID          CA PMA Chargeback          MM/DD/YY HH:MM:SS
--            Acctdefs Cbdefs  Query Data Period  Options  Exit  Help
+-- CBCELME ----- Charge Elements Entry -----+
|   Panel Exit Help                               |
|-----|
|   Type information. Then select an action.      |
|   Version . . . : PROD                          |
|   ORD Type . . . : MBJ                          |
|   Charge Element : DISK-IO-CHARGE__             |
|   Charge Unit . . DISK-IO_____                |
|   Normalizer . . . _____                  |
|   Default Rate . . .50000_____               |
|   Maximum Charge . _____                  |
|   Minimum Charge . _____                  |
|   F5=Save  F6=Delete  F7=Unit  F8=Norm  F11=Rate |
+-----+
Command ==> _____
F1=Help  F3=Exit  F4=Prompt  F9=Command  F10=Action Bar  F12=Cancel  PA1=Susp
    
```

As you can see from the panel above, we created a Charge Element named DISK-IO-CHARGE. The DISK-IO-CHARGE is calculated by multiplying the value of the charge unit, DISK-IO by the default rate, .50.

## Example 2: Defining a Normalized Complex Charge Unit with a Conditional Rate

Now, return to our Extended Charging Example. The algorithm is:

```
Charge Unit   Normalizer           Charge Element
@CPU-TIME *   SYSTEM *   Condit'l Rate = CPU-CHARGE
```

Based on the algorithm, we start the CPU-CHARGE charge element definition following a path from the Charge Elements primary panel to the Charge Elements Entry panel, shown below.

```

USERID          CA PMA Chargeback          MM/DD/YY HH:MM:SS
---            +---+ +---+ +---+ +---+ +---+ +---+ +---+
Acctdefs Cbdefs Query Data Period Options Exit Help
+-- CBCELME ----- Charge Elements Entry -----+
|   Panel Exit Help                               |
|-----|
| Type information. Then select an action.         |
|-----|
| Version . . . : PROD                            |
| ORD Type . . . : MBJ                            |
| Charge Element : CPU-CHARGE_____              |
|-----|
| Charge Unit . . @CPU-TIME_____                 |
| Normalizer . . . SYSTEM_____                  |
| Default Rate . . .4000_____                    |
| Maximum Charge . 5000.00000_____               |
| Minimum Charge . __100.00000_____              |
|-----|
| F5=Save F6=Delete F7=Unit F8=Norm F11=Rate     |
+-----+
Command ==> _____
F1=Help F3=Exit F4=Prompt F9=Command F10=Action Bar F12=Cancel PA1=Susp

```

### So far, we have:

- Started the definition of a charge element called CPU-CHARGE that is associated with an ORD called MBJ
- Provided a user-defined complex charge unit name: @CPU-TIME, which must be defined
- Provided a user-defined normalizer name: SYSTEM, which must be defined
- Defined a default rate for the charge element: CPU-CHARGE
- Provided minimum and maximum charge values for the charge element

### We must now:

- Define @CPU-TIME (complex unit)
- Specify the normalizer weight or factor
- Provide normalizer qualifiers

- Define the conditional rates
- Provide rate qualifiers

We now proceed to the Charge Units Entry panel to define our complex unit:  
@CPU-TIME.

**Note:** Remember, you have the option of performing any of the following actions in the order you want. Upon completion of any of these actions, you are returned to the Charge Elements Entry panel.

**F7**

Takes you to the Units Entry panel (section Charge Units Entry Panel).

**F8**

Takes you to the Normalizer Entry panel (section Normalizer Entry Panel).

**F11**

Takes you to the Qualified Rates Entry panel (section Qualified Rates Entry Panel).

## Charge Units Entry Panel

You only select this panel, using F7 on the Charge Elements Entry panel, when you are defining a **complex** charge unit. A complex charge unit is a user-defined entity (indicated by the @ prefix) that is a computed item. The algorithm for @CPU-TIME is shown below. This panel is used to validate the Charge Unit name on the Charge Elements Entry panel shown as a protected display field.

```

USERID                CA PMA Chargeback                MM/DD/YY HH:MM:SS
--  Acctdefs Cbdefs Query Data Period Options Exit Help
+-- CBCELMU ----- Charge Units Entry -----+
| Panel Exit Help |
|-----|
| Type information. Then select an action. |
| Version . . : PROD |
| ORD Type . . : MBJ |
| Charge Unit : @CPU-TIME |
|
| More: - + ____ Row 0000 of 0000 |
| Cmd ORD Field/@Unit Aop Field/Constant Aop |
| SRB-TIME_____ * '.5' _____ + |
| TCB-TIME_____ * '.5' _____ - |
| _____ - _____ - |
| _____ - _____ - |
|
| F2=Xref F5=Save F6=Delete F7=Bkwd F8=Fwd F11=Expand |
+-----+

Command ==> _____
F1=Help F3=Exit F4=Prompt F9=Command F10=Action Bar F12=Cancel PA1=Susp

```

**Note:** The first time this panel appears, you are in **insert** mode; no lines appear under the Cmd column, the scroll bar does not show a row count, and the only active panel function keys are F2, F5, and F11. When you press F5 (Save), a message appears telling you the **insert** is successful. At this point, you are in **update** mode. The panel scroll bar provides a row count, the Cmd column is active (lines appear under the column) and **all** panel function keys are active. Pressing F5 (Save) displays a message telling you the **update** is successful.

Next is a description of the Charge Units Entry panel.

### Access

The Charge Units Entry panel appears when one of these events occurs:

- You press **F2** (Create) on the Charge Units Primary panel shown in Charge Units Primary Panel.
- You press **F7** (Unit) on the Charge Elements Entry panel shown in Charge Elements Entry Panel.
- You return from the Expanded Units Entry panel.

-----

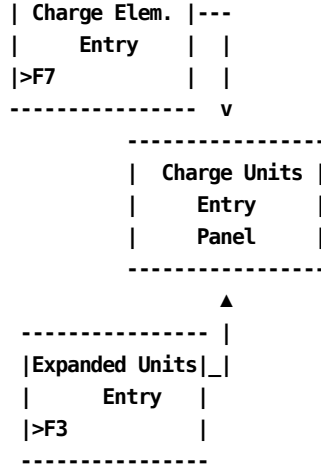

**Scrolling**

F7 and F8 let you scroll backward and forward through the charge unit entries. You can also use the scroll bar to move through the charge unit entries.

**Input**

The Charge Units Entry panel contains the following input fields:

**Cmd**

Use this column to specify commands. Valid commands include:

D Deletes lines from the calculation.

I Inserts lines into the calculation using the Unit Insert (CBCUNII) pop-up window. Refer to Sample Entry Panel Insert Pop-Up Window for information on how to use the Insert window.

**ORD Field/@Unit**

Can refer to either a valid field defined in the ORD or another user-defined charge unit (indicated by the @ prefix) applying to the same ORD. Thus, complex calculations can be performed in an hierarchical manner.

**Caution** Sequencing of items is critical.

**Aop**

(Arithmetic operator): + (addition), - (subtraction), \* (multiplication), / (division).

**Field/Constant**

List any constants or ORD fields used in the definition of a complex charge unit.

**Note:** When specifying constants, they **must** be enclosed in single quotes. For example, '.5' as shown on the panel on the preceding page.

**Aop**

(Arithmetic operator) a **link** used to continue the calculation: + (addition), - (subtraction), \* (multiplication), / (division).

### **Actions**

#### **F2=Xref**

Gives you a cross-referenced listing of other complex units that reference this complex unit.

#### **F5=Save**

Lets you add and update rows in the Charge Units table.

#### **F6=Delete**

Lets you delete all entries from the Charge Units table.

#### **F7=Bkwd**

Lets you scroll backward through the table.

#### **F8=Fwd**

Lets you scroll forward through the table.

#### **F11=Expand**

Presents you with an eight-line display of the Charge Units Entry panel.

## Expanded Units Entry Panel

The following panel appears when you press F11 (Expand) on the Charge Units Entry panel. The only difference between the Charge Unit Entry and Expanded Entry panels is the Version, ORD Type, and Charge Unit protected fields are not displayed. This allows you to view more information on a single panel. The Expanded Entry panel functions in the same way as the Entry panel from which it was called.

```

USERID          CA PMA Chargeback          MM/DD/YY HH:MM:SS
--  Acctdefs  Cbdefs  Query  Data  Period  Options  Exit  Help
+-- CBCELMV ----- Expanded Units Entry -----+
      Panel  Exit  Help
      -----
      Type information. Then select an action.
      More: - + _____ Row 0001 of 0002
      Cmd  ORD Field/@Unit  Aop  Field/Constant  Aop
      -   SRB-TIME_____ *  '.5'_____ +
      -   TCB-TIME_____ *  '.5'_____ -
      _____ - _____ -
      _____ - _____ -
      _____ - _____ -
      _____ - _____ -
      _____ - _____ -
      F2=Xref  F5=Save  F6=Delete  F7=Bkwd  F8=Fwd
+-----+

Command ==> _____
F1=Help  F3=Exit  F4=Prompt  F9=Command  F10=Action Bar  F12=Cancel  PA1=Susp
    
```

## Examples: Defining a Complex Charge Unit

Using the Extended Charging Example and the Charge Elements Entry panel shown in Charge Elements Entry Panel.

**So far, we have:**

- **named:**
  - A charge element
  - A complex charge unit
  - A normalizer
- **provided**
  - A default rate
  - Minimum and maximum charge values

**We must now:**

- Define @CPU-TIME (complex unit)
- Define the conditional rates
- Define a normalizer
- Define qualifiers

The following examples show you how to define a Complex Unit.

## Example 1: Defining a Complex Unit without a Constant

In our Extended Charge Example, we use a user-defined complex charge unit: @CPU-TIME.

```

Complex
Charge Unit      Normalizer                Charge Element
-----
|@CPU-TIME| *   System      *   Condit'l Rate = CPU-CHARGE
-----
    
```

@CPU-TIME is composed of the calculated result of two fields defined within an ORD: SRB-TIME + TCB-TIME. The following example shows you how to define a complex charge unit without a constant.

```

USERID          CA PMA Chargeback          MM/DD/YY HH:MM:SS
--            +---+ +---+ +---+ +---+ +---+ +---+ +---+
Acctdefs Cbdefs Query Data Period Options Exit Help
+--- CBCELMU ----- Charge Units Entry -----+
|
|   Panel Exit Help
|-----|
|   Type information. Then select an action.
|
|   Version . . . : PROD
|   ORD Type . . . : MBJ
|   Charge Unit  : @CPU-TIME
|
|                               More: - + _____ Row 0000 of 0000
|   Cmd  ORD Field/@Unit  Aop Field/Constant  Aop
|
|   SRB-TIME_____ + TCB-TIME_____ -
|   _____ - _____ -
|   _____ - _____ -
|
|   F2=Xref F5=Save F6=Delete F7=Bkwd F8=Fwd F11=Expand
+-----+
Command ==>
F1=Help F3=Exit F4=Prompt F9=Command F10=Action Bar F12=Cancel PA1=Susp
    
```

## Example 2: Defining a Complex Unit with a Constant

This example shows the definition of a complex charge unit named @IO-COUNT. It is composed of DISK-IO, TAPE-IO, and OTHER-IO. The rate is per 1000 EXCPs.

Note that the AOP and Field/Constant columns are not blank, but contain an arithmetic operator and a numeric constant.

```

USERID                               CA PMA Chargeback                MM/DD/YY HH:MM:SS
---  Acctdefs  Cbdefs  Query  Data  Period  Options  Exit  Help
+-- CBCELMU ----- Charge Units Entry -----+
|                                     |
|                                     |
|                                     |
| Type information. Then select an action. |
|                                     |
| Version . . . : PROD                |
| ORD Type . . . : MBJ                |
| Charge Unit : @IO-COUNT              |
|                                     |
|                                     |
| More: - + _____ Row 0000 of 0000 |
| Cmd  ORD Field/@Unit  Aop Field/Constant  Aop |
| DISK-IO _____ * '.10' _____ + |
| TAPE-IO _____ * '.15' _____ + |
| OTHER-IO _____ * '.22' _____ / |
| _____ - '1000' _____ - |
|                                     |
| F2=Xref F5=Save F6=Delete F7=Bkwd F8=Fwd F11=Expand |
+-----+
Command ==> _____
F1=Help F3=Exit F4=Prompt F9=Command F10=Action Bar F12=Cancel PA1=Susp

```

**Note:** When specifying constants, they **must** be enclosed in single quotes, or CA PMA Chargeback assumes the constant is an ORD element name. For example, '.5' as shown on the panel in Charge Units Entry Panel.

## Qualified Rates Entry Panel

The Qualified Rates entry panel is used to associate different rates with an algorithm based on certain criteria. In the panel below, we are qualifying the rates used in the CPU-CHARGE charge element based on **shift**. The protected fields at the top of the panel indicate we are defining rates for the CPU-CHARGE charge element for MBJ ORDs. We use the lower part of the panel to name the rate qualifier and its associated rate - the rate that is applied when the qualifying condition is **true**.

**Note:** Qualifiers are tested one at a time. CA PMA Chargeback assigns the rate associated with the first qualifier that is **true**. Therefore, the order in which you define qualifiers is important.

If none of the qualifying conditions are met, the **default** rate specified on the Charge Elements Entry panel (section Charge Elements Entry Panel) is used.

```

USERID          CA PMA Chargeback          MM/DD/YY HH:MM:SS
--- Acctdefs Cbdefs Query Data Period Options Exit Help
+-- CBCELMR ----- Qualified Rates -----+
|   Panel Exit Help
|-----|
|   Type information. Then select an action.
|
|   Version . . . : PROD
|   ORD Type . . . : MBJ
|   Charge Element : CPU-CHARGE
|
|                                     More: - + ____ Row 0001 of 0003
|   Cmd  Qualifier          Rate
|   -   @SHIFT1_____ 200.00000_____
|   -   @SHIFT2_____ 150.00000_____
|   -   @SHIFT3_____ 100.00000_____
|   -   _____
|
|   F2=Qual  F5=Save  F6=Delete  F7=Bkwd  F8=Fwd  F11=Expand
+-----+

Command ==> _____
F1=Help  F3=Exit  F4=Prompt  F9=Command  F10=Action Bar  F12=Cancel  PA1=Susp
    
```

**Note:** The first time this panel appears, you are in **insert** mode; no lines appear under the Cmd column, the scroll bar does not show a row count, and the only active panel function keys are F2, F5, and F11. When you press F5 (Save), a message appears telling you the **insert** is successful. At this point, you are in **update** mode. The panel scroll bar provides a row count, the Cmd column is active (lines appear under the column) and **all** panel function keys are active. Pressing F5 (Save) displays a message telling you the **update** is successful.

Next is a description of the Qualified Rates entry panel.

### Access

The Qualified Rates Entry panel appears when one of these events occurs:

- You press **F11** (Rate) on the Charge Elements Entry panel shown in Charge Elements Entry Panel.
- You return from the Expanded Qualified Rates Entry panel.

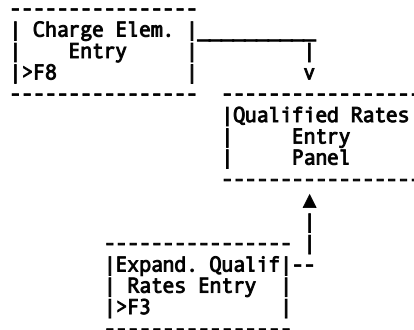

### **Scrolling**

F7 and F8 let you scroll backward and forward through the list of qualifiers and rates. You can also use the scroll bar to move through the listed normalizers.

### **Input**

The Qualified Rates Entry panel contains the following input fields:

#### **Cmd**

This column is used to specify commands. Valid commands include:

D Deletes lines from the qualification.

I Inserts lines into the qualification using the Qualified Rate Insert (CBCQLRI) pop-up window. Refer to Sample Entry Panel Insert Pop-Up Window for information on how to use the Insert window.

#### **Qualifier**

A user-defined name that provides the test to determine if a conditional rate is applied. The ORD elements that comprise the Qualifier name are defined using the Qualifier Entry panel (section Qualifier Entry Panel).

#### **Rate**

The actual amount to be used if the condition is met.

### **Actions**

#### **F2=Qual**

Takes you to the Qualifier Entry panel (section Qualifier Entry Panel).

#### **F5= Save**

Lets you save add and update information.

#### **F6= Delete**

Lets you delete rows from the table.

#### **F7=Bkwd**

Lets you scroll backwards through the table.

#### **F8=Fwd**

Lets you scroll forward through the table.

#### **F11=Expand**

Presents you with an eight-line display of the Qualified Rates Entry panel.

To continue with the Extended Charging Example, we press F2 (QUAL) to define our rate qualifiers. This action takes us to the Qualifier Entry panel shown in Qualifier Entry Panel.

### Expanded Qualified Rates Entry Panel

The following panel appears when you press F11 (Expand) on the Qualified Rates Entry panel. The only difference between the Qualified Rates and Expanded Entry panels is the Version, ORD Type, and Charge Unit protected fields are not displayed. This allows you to view more information on a single panel. The Expanded Entry panel functions in the same way as the Entry panel from which it was called.

```

USERID          CA PMA Chargeback          MM/DD/YY HH:MM:SS
--  Acctdefs  Cbdefs  Query  Data  Period  Options  Exit  Help
+-- CBCELMs ----- Expanded Qualified Rates Entry-----+
      Panel  Exit  Help
+-----+
      Type information. Then select an action.
      More: - + ____ Row 0000 of 0000
      Cmd  Qualifier          Rate
      -   @SHIFT1          200.00000
      -   @SHIFT2          150.00000
      -   @SHIFT3          100.00000
      -   _____
      -   _____
      -   _____
      -   _____
      -   _____
      F2=Qual  F5=Save  F6=Delete  F7=Bkwd  F8=Fwd  F11=Expand
+-----+
Command ==> _____
F1=Help  F3=Exit  F4=Prompt  F9=Command  F10=Action Bar  F12=Cancel  PA1=Susp
    
```

## Examples: Defining Conditional Rates

Using the Extended Charging Example:

**So far, we have:**

- **named:**
  - A charge element
  - A complex charge unit
  - A normalizer
- **provided**
  - A default rate
  - Minimum and maximum charge values
- **defined**
  - A complex unit

**We must now:**

- Define the conditional rates
- Define qualifiers
- Define a normalizer

The next two examples show you how to define your conditional (qualified) rates.

## Example 1: Defining Conditional Rates by Qualifier

In our Extended Charge Example, we want a specific rate used in the algorithm when a given condition is found to be true. A qualifier, **shift**, is used to determine which rate is applied.

```

Complex
Charge
Unit          Normalizer  -----  Charge Element
@CPU-TIME *   SYSTEM      * |Condit'l Rate| = CPU-CHARGE
-----
    
```

To define the conditional rates, list the qualifier name and the associated rate for each qualifier you want tested, as shown on the panel below.

```

USERID          CA PMA Chargeback          MM/DD/YY HH:MM:SS
---            +---+ CBCELMR -----+
+--- CBCELMR -----+ Qualified Rates -----+
| Panel Exit Help |
|-----|
| Type information. Then select an action. |
|-----|
| Version . . . : PROD |
| ORD Type . . . : MBJ |
| Charge Element : CPU-CHARGE |
|-----|
| Cmd Qualifier          Rate          |
|-----|
| - @SHIFT1             200.00000 |
| - @SHIFT2             150.00000 |
| - @SHIFT3             100.00000 |
|-----|
| F2=Qual  F5=Save  F6=Delete  F7=Bkwd  F8=Fwd  F11=Expand |
+-----+
Command ==>
F1=Help  F3=Exit  F4=Prompt  F9=Command  F10=Action Bar  F12=Cancel  PA1=Susp
    
```

When a qualifying condition is met, the appropriate rate is applied.

**Note:** Qualifiers are tested one at a time. CA PMA Chargeback assigns the rate associated with the first qualifier that is "true." Therefore, the order in which you define qualifiers is important.

For example, if the MBJ ORD record meets the @SHIFT1 qualification, then the rate charged is 200 per unit. If the record does not meet the SHIFT1 qualification, then the @SHIFT2 qualification is tested, and so on. If none of the qualifiers' conditions are met, the **default** rate specified on the Charge Elements Entry panel (section Charge Elements Entry Panel) is used.

## Example 2: Defining Conditional Rates by Qualifier

In this example, we are extending the algorithm we used in Example 1 (on the previous page) to include a 50% discount for CPU weekend usage. As in the previous example, we must list each qualifier and its associated rate for each shift which now includes weekend rates for each shift. The **W** stands for weekend.

**Note:** You must scroll the panel to see the rate for @SHIFT2 which is 150.00000 and @SHIFT3 which is 100.00000

When a qualifying condition is met, the appropriate rate is applied.

```

USERID          CA PMA Chargeback          MM/DD/YY HH:MM:SS
-----  Acctdefs  Cbdefs  Query  Data  Period  Options  Exit  Help
+---  CBCELMR  -----  Qualified Rates  -----+
      Panel  Exit  Help
      -----
      Type information. Then select an action.
      -----
      Version . . . : PROD
      ORD Type . . . : MBJ
      Charge Element : CPU-CHARGE
      -----
      Cmd  Qualifier          Rate          More: - + ____  Row 0001 of 0006
      -   @SHIFT1W          100.0000
      -   @SHIFT2W          75.00000
      -   @SHIFT3W          50.00000
      -   @SHIFT1           200.00000
      -----
      F2=Qual  F5=Save  F6=Delete  F7=Bkwd  F8=Fwd  F11=Expand
+-----+
Command ==> _____
F1=Help  F3=Exit  F4=Prompt  F9=Command  F10=Action Bar  F12=Cancel  PA1=Susp
    
```

Using the panel above, if the MBJ ORD record meets the @SHIFT1W qualification, then the rate charged is 100 per unit. If the record does not meet the @SHIFT1W qualification, then the @SHIFT2W qualification is tested. The testing continues through @SHIFT3 until a true condition is encountered. However, if none of the qualifiers' conditions are met, the **default** rate specified on the Charge Elements Entry panel is used.

**Tip**

Test for the weekend first.

## Qualifier Entry Panel

A qualifier establishes a conditional test resulting in a true or false condition. Qualifiers can be used with qualified rates, normalizers, and modifiers in the definition of conditional rates. The following panel set is used to define qualifiers.

The Qualifiers Entry panel is used to define the range of a qualifier.

You arrived at this panel by pressing F2 (Qualifier) on the Qualified Rates entry panel shown in Qualified Rates Entry Panel.

```

USERID                      CA PMA Chargeback              MM/DD/YY HH:MM:SS
---  Acctdefs Cbdefs  Query  Data  Period  Options  Exit  Help
+-- CBCELMQ ----- Qualifier Entry -----+
|      Panel  Exit  Help
|-----+
|      Type information. Then select an action.
|
|      Version . : PROD
|      ORD Type . : MBJ
|      Qualifier : @SHIFT1
|
|      ORD                      More: - + ____ Row 0001 of 0002
|      Cmd Field/@Qualifier      Rop  Field/Constant      Lop
|
|      START-TIME _____ >= '0800' _____ and
|      START-TIME _____ <  '1600' _____
|
|      _____ -- _____
|
|      F2=Xref F5=Save F6=Delete F7=Bkwd F8=Fwd F11=Expand
+-----+
Command ==> _____
F1=Help F3=Exit F4=Prompt F9=Command F10=Action Bar F12=Cancel PA1=Susp

```

**Note:** The first time this panel appears, you are in **insert** mode; no lines appear under the Cmd column, the scroll bar does not show a row count, and the only active panel function keys are F2, F5, and F11. When you press F5 (Save), a message appears telling you the **insert** is successful. At this point, you are in **update** mode. The panel scroll bar provides a row count, the Cmd column is active (lines appear under the column) and **all** panel function keys are active. Pressing F5 (Save) displays a message stating that the **update** was successful.

Next is a description of the Qualifier Entry panel.

### Access

The Qualifier Entry panel appears when one of these events occurs:

- You press **F2** (Qualifier) on the Qualified Rates panel shown in Qualified Rates Entry Panel.
- You return from the Expanded Qualifier Entry panel shown in Expanded Qualifier Entry Panel.

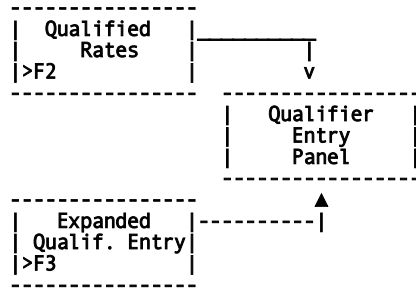

### Scrolling

F7 and F8 let you scroll backward and forward through the Qualifiers definition list. You can also use the scroll bar to move through the entries.

### Input

The following Qualifier Entry panel fields are available for input:

#### Cmd

This column is used to specify commands. Valid commands include:

D Deletes individual lines from the conditional test.

I Inserts lines into the conditional test using the Qualifier Insert (CBCQALI) pop-up window. Refer to page Sample Entry Panel Insert Pop-Up Window for information on how to use the insert window.

#### ORD Field/@Qualifier

You use this column to identify the ORD Field or Qualifier name to be used. The contents of this Field Name is compared with the Field/Constant identifier provided in the Field/Constant column. Defines the qualifier named in the protected display field at the top of the panel.

**Note:** A qualifier can refer to other qualifiers. Nesting is permitted to any level.

#### Rop

Relational operator: acceptable entries include: < (less than), > (greater than), = (equal), or combinations, such as =< (equal to or less than) and &x'5f. = (not equal).

#### Field/Constant

Defines the desired value, either another ORD Field or a specific result, that is used in the comparison with the ORD Field/@Qualifier.

#### Lop

(Logical operator) acceptable operators are: **and** and **or**.

### Actions

#### F2=Xref

Gives you a cross-referenced listing of all charge elements, other qualifiers, modifiers, and so forth that reference this qualifier.

#### F5=Save

Lets you add and update rows in the table.

#### F6=Delete

Deletes the entire qualifier.

#### F7=Bkwd

Lets you scroll backwards through the table.

**F8=Fwd**

Lets you scroll forward through the table.

**F11=Expand**

Gives you an eight-line display of the Qualifier Entry panel.

## Expanded Qualifier Entry Panel

The following panel appears when you press F11 (Expand) on the Qualifier Entry panel shown in . The only difference between the two panels is the Version, ORD Type, and Qualifier protected fields are not displayed. This allows you to view more information on a single panel. The Expanded Qualifier Entry panel functions in the same way as the entry panel from which it was called.

```

USERID                               CA PMA Chargeback                               MM/DD/YY HH:MM:SS
--  Acctdefs Cbdefs  Query  Data  Period  Options  Exit  Help
+-- CBCELMT ---- Expanded Qualifier Entry -----+
|   Panel Exit Help                               |
|-----|
|   Type information. Then select an action.      |
|   ORD                                           More: - + ____ Row 0001 of 0002 |
| Cmd  Field/@Qualifier  Rop  Field/Constant  Lop |
| -   START-TIME_____ >= '0800'_____ and |
| -   START-TIME_____ <  '1600'_____   |
| -   _____      -   _____         |
| -   _____      -   _____         |
| -   _____      -   _____         |
| -   _____      -   _____         |
| -   _____      -   _____         |
| -   _____      -   _____         |
|-----|
|   F2=Xref  F5=Save  F6=Delete  F7=Bkwd  F8=Fwd |
+-----+

Command ==> _____
F1=Help  F3=Exit  F4=Prompt  F9=Command  F10=Action Bar  F12=Cancel  PA1=Susp
    
```

## Examples: Defining Qualifiers

Using the Extended Charging Example:

**So far, we have:**

- **named:**
  - A charge element
  - A complex charge unit
  - A normalizer
- **provided**
  - A default rate
  - Minimum and maximum charge values
- **defined**
  - A complex unit
  - Conditional rates

**We must now:**

- Define qualifiers
- Define a normalizer

The examples in Example 1: Qualifying an ORD by Start Time and Example 2: Qualifying an ORD by Day of Week & Start Time, show you how to define qualifiers.

### Example 1: Qualifying an ORD by Start Time

This example shows the definition of @SHIFT1. It represents a true condition when the field START-TIME of MBJ ORD Types is greater than or equal to '0800' and less than '1600'. When this condition is **true**, the rate used in the calculation comes from the @SHIFT1 qualified rate defined on the Qualified Rates entry panel shown earlier in this chapter.

```

USERID          CA PMA Chargeback          MM/DD/YY HH:MM:SS
---            +---+ CBCELMQ ----- Qualifier Entry -----+
                Panel Exit Help
                -----
                Type information. Then select an action.
                -----
                Version . : PROD
                ORD Type . : MBJ
                Qualifier : @SHIFT1
                -----
                ORD          More: - + ____ Row 0001 of 0002
                Cmd Field/@Qualifier  Rop  Field/Constant  Lop
                -----
                -   START-TIME          >=  '0800'          and
                -   START-TIME          <   '1600'          ___
                -   _____          ___                ___
                -   _____          ___                ___
                -----
                F2=Xref F5=Save F6=Delete F7=Bkwd F8=Fwd F11=Expand
                -----
                +-----+
                Command ==> _____
                F1=Help  F3=Exit  F4=Prompt  F9=Command  F10=Action Bar  F12=Cancel  PA1=Susp
    
```

In Example 1 in Example 1: Defining Conditional Rates by Qualifier, we created qualifier names for two more shifts, @SHIFT2 and @SHIFT3, which also have to be defined.

**Note:** Their definition is shown on the next page.

### Qualifier Definition of @SHIFT2 & @SHIFT3

```

+-----+
| Version . PROD                                     |
| ORD Type . MBJ                                   |
| Qualifier @SHIFT2                               |
|          ORD          More: - +          Row 0001 of 0002 |
|Cmd Field/@Qualifier  Rop  Field/Constant  Lop |
|-----+-----+
| _  START-TIME_____ >=  '1600'_____ and |
| _  START-TIME_____ <  '2400'_____   |
+-----+
| Qualifier      : @SHIFT3                         |
|          ORD          More: - + _____ Row 0001 of 0002 |
|Cmd Field/@Qualifier  Rop  Field/Constant  Lop |
|-----+-----+
| _  START-TIME_____ >=  '0000'_____ and |
| _  START-TIME_____ <  '0800'_____   |
+-----+

```

## Example 2: Qualifying an ORD by Day of Week & Start Time

This example shows how to continue the definition of shift qualifiers to include the definition of @SHIFT1W as shown in Example 2 in Example 2: Defining Conditional Rates by Qualifier.

The same logic applies to these definitions as that used in earlier examples. @SHIFT1W represents a true condition when the field START-TIME is less than or equal to 1600, and START-TIME is greater than or equal to 0800, **and** the day of week is greater than or equal to 6 (Saturday) for MBJ ORD Types. When this condition is **true**, the rate used in the calculation comes from the algorithm for @SHIFT1W shown in Example 2: Defining Conditional Rates by Qualifier.

```

USERID                               CA PMA Chargeback                MM/DD/YY HH:MM:SS
---  Acctdefs  Cbdefs  Query  Data  Period  Options  Exit  Help
+-- CBCELMQ ----- Qualifier Entry -----+
| Panel  Exit  Help |
|-----|
| Type information. Then select an action. |
| Version . : PROD |
| ORD Type . : MBJ |
| Qualifier : @SHIFT1W |
|
| ORD          More: - + ____ Row 0001 of 0003 |
| Cmd Field/@Qualifier  Rop  Field/Constant  Lop |
|-----|-----|-----|-----|
| START-TIME _____ >= '0800' _____ and |
| START-TIME _____ <= '1600' _____ and |
| DAY-OF-WEEK _____ >= '6' _____   |
|-----|-----|-----|-----|
| F2=Xref F5=Save F6=Delete F7=Bkwd F8=Fwd F11=Expand |
+-----+

Command ==> _____
F1=Help F3=Exit F4=Prompt F9=Command F10=Action Bar F12=Cancel PA1=Susp
    
```

In Example 2 in Example 2: Defining Conditional Rates by Qualifier, we created qualifier names for two more shifts, @SHIFT2W and @SHIFT3W, which also have to be defined. Their definition is shown next.

**Qualifier Definition of @SHIFT2W & @SHIFT3W**

```

+-----+
| Version .   PROD                                     |
| ORD Type .  MBJ                                     |
| Qualifier   @SHIFT2W                               |
|                                                     |
|   ORD                More: - +      Row 0001 of 0002 |
|Cmd  Field/@Qualifier  Rop  Field/Constant  Lop      |
|                                                     |
| _   @SHIFT2                and                    |
| _   DAY-OF-WEEK_____  >=  '6'                    |
| -   _____  --  _____  ___                |
+-----+
| Qualifier : @SHIFT3W                               |
|                                                     |
|   ORD                More: - + _____ Row 0001 of 0003 |
|Cmd  Field/@Qualifier  Rop  Field/Constant  Lop      |
|                                                     |
| _   @SHIFT3                and                    |
| _   DAY-OF-WEEK_____  >=  '6'                    |
| -   _____  --  _____  ___                |
+-----+

```

### Example 3: Defining a Qualifier Using Other Qualifiers

This example shows you how to define a qualifier named @NONPRIME using two other qualifiers.

```

USERID          CA PMA Chargeback          MM/DD/YY HH:MM:SS
--  Acctdefs  Cbdefs  Query  Data  Period  Options  Exit  Help
+-- CBCELMQ ----- Qualifier Entry -----+
| Panel  Exit  Help |
|-----|
| Type information. Then select an action. |
| Version . : PROD |
| ORD Type . : MBJ |
| Qualifier : @NONPRIME |
|
| ORD          More: - + ____ Row 0001 of 0001 |
| Cmd Field/@Qualifier  Rop  Field/Constant  Lop |
|
| @SHIFT2_____ |
| @SHIFT3_____ |
| _____ |
| _____ |
|
| F2=Xref F5=Save F6=Delete F7=Bkwd F8=Fwd F11=Expand |
+-----+
Command ==> _____
F1=Help F3=Exit F4=Prompt F9=Command F10=Action Bar F12=Cancel PA1=Susp
    
```

### Example 4: Qualifying a Normalizer

This is an example of a qualifier being used by a normalizer. It shows how to define qualifiers for a normalizer named SYSTEM. On the Normalizer Entry panel, we provided two qualifier names: @CPUIDA and @CPUIDB and a normalization factor (a percentage) associated with each qualifier.

**Note:** In order to define qualifiers for a normalizer, you must invoke Qualifiers from the Cbdefs pull-down and follow the path to the Qualifier Entry panel.

The panel below shows you how to provide the conditions for which the qualifier is valid.

```

USERID                               CA PMA Chargeback                MM/DD/YY HH:MM:SS
---  Acctdefs Cbdefs Query Data Period Options Exit Help
+-- CBCELMQ ----- Qualifier Entry -----+
| Panel Exit Help |
|-----|
| Type information. Then select an action. |
| Version . : PROD |
| ORD Type . : MBJ |
| Qualifier : @CPUIDA |
|
| ORD          More: - + _____ Row 0001 of 0001 |
| Cmd Field/@Qualifier Rop Field/Constant Lop |
| CPU ID_____ = 'A' _____ |
| _____ |
| _____ |
| _____ |
|
| F2=Xref F5=Save F6=Delete F7=Bkwd F8=Fwd F11=Expand |
+-----+

Command ==> _____
F1=Help F3=Exit F4=Prompt F9=Command F10=Action Bar F12=Cancel PA1=Susp
    
```

**Note:** You must also define a qualifier for @CPUIDB stating the conditions under which it is valid. Its definition would be as follows:

```

+-----+
| Qualifier : @CPUIDB |
|
| ORD          More: - + _____ Row 0000 of 0000 |
| Cmd Field/@Qualifier Rop Field/Constant Lop |
| CPU ID_____ = 'B' _____ |
+-----+
    
```

## Normalizer Entry Panel

You use this panel to define and qualify a normalizer you named on a Charge Elements Entry panel (section Charge Elements Entry Panel). Normalizers are **only** associated with charge units and are weighting factors (percentages) that are applied to a **charge unit's** calculated value **before** rates are applied. In the example below, we are providing a definition for a normalizer called SYSTEM.

```

USERID          CA PMA Chargeback          MM/DD/YY HH:MM:SS
---            +-- CBCELMN ----- Normalizer Entry -----+
                Panel Exit Help
                -----+
                |
                | Type information. Then select an action.
                |
                | Version . : PROD
                | ORD Type . : MBJ
                | Normalizer : SYSTEM
                |
                | More: - + ____ Row 0000 of 0000
                | Cmd Qualifier          Percentage
                |
                | @CPUIDA _____ 100 _____
                | @CPUIDB _____ 530.8 _____
                | _____
                | _____
                |
                | F2=Xref F5=Save F6=Delete F7=Bkwd F8=Fwd F11=Expand
                |
                +-----+
                |
                | Command ==> _____
                | F1=Help F3=Exit F4=Prompt F9=Command F10=Action Bar F12=Cancel PA1=Susp
                |
                +-----+
    
```

**Note:** The first time this panel appears, you are in **insert** mode; no lines appear under the Cmd column, the scroll bar does not show a row count, and the only active panel function keys are F2, F5, and F11. When you press F5 (Save), a message appears telling you the **insert** is successful. At this point, you are in **update** mode. The panel scroll bar provides a row count, the Cmd column is active (lines appear under the column) and **all** panel function keys are active. Pressing F5 (Save) displays a message stating the **update** was successful.

The following is a description of the Normalizer Entry panel.

### Access

The Normalizer Entry panel appears when one of these events occurs:

- When **F8** (Norm) is pressed on the Charge Elements Entry panel shown in Charge Elements Entry Panel.
- You return from the Expanded Normalizer Entry panel.

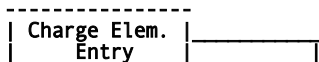

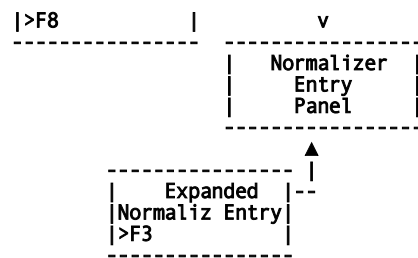

### Scrolling

F7 and F8 let you scroll backward and forward through the Qualifier and Percentage columns. You can also use the scroll bar to move through the list.

### Input

The Normalizer Entry panel contains the following input fields:

#### Cmd

Used to specify commands. Valid commands include:

- D deletes qualifiers from the qualification.
- I inserts qualifiers into the qualification

#### Qualifier

The user-defined name of a conditional test that is applied to a charge unit.

#### Percentage

The weighting factor (**a percentage**) you want applied to a charge unit, based on the qualification tests you define. For example, 20%.

To increase a value by 20%, enter 120.

To decrease a value by 20%, enter 80.

The precision for this field is 99999999V99999999.

### Actions

#### F2=Xref

Gives you a cross-referenced listing of all charge elements that reference this normalizer.

#### F5=Save

Lets you save the qualification(s).

#### F6=Delete

Lets you delete the qualification(s).

#### F7=Bkwd

Lets you scroll backwards through the panel.

#### F8=Fwd

Lets you scroll forward through the panel.

#### F11=Expand

Presents you with an eight-line display of the Normalizer List panel.

## Expanded Normalizer Entry Panel

The following panel appears when you press F11 (Expand) on the Normalizer Entry panel. The only difference between the Normalizer Entry and Expanded Entry panels is the Version, ORD Type, and Normalizer protected fields are not displayed. This allows you to view more information on a single panel. The Expanded Entry panel functions in the same way as the Entry panel from which it was called.

```

USERID          CA PMA Chargeback          MM/DD/YY HH:MM:SS
--  Acctdefs  Cbdefs  Query  Data  Period  Options  Exit  Help
+-- CBCELM0 ----- Expanded Normalizer Entry -----+
|   Panel  Exit  Help                                     |
|-----|
| Type information. Then select an action.                |
|                                                       |
| Cmd Qualifier          More: - + ____ Row 0001 of 0002 |
| @CPUIDA                100 _____                 |
| @CPUIDB                530.8 _____                 |
| _____                 _____                 |
| _____                 _____                 |
| _____                 _____                 |
| _____                 _____                 |
| _____                 _____                 |
| F2=Xref  F5=Save  F6=Delete  F7=Bkwd  F8=Fwd         |
+-----+
Command ==> _____
F1=Help  F3=Exit  F4=Prompt  F9=Command  F10=Action Bar  F12=Cancel  PA1=Susp
    
```

## Examples: Defining a Normalizer

Using the Extended Charging Example:

**So far, we have:**

**named:**

- A charge element
- A complex charge unit
- A normalizer

■ **provided**

- A default rate
- Minimum and maximum charge values

■ **defined**

- A complex unit
- Conditional rates
- Qualifiers

**We must now:**

- Define a normalizer

The next section shows you how to define a normalizer named SYSTEM.

## Example: Normalizing a Complex Charge Unit

```

Charge      -----
Unit       |Normalizer |                      Charge Element
CPU-TIME * | SYSTEM   | * Condit'l Rate = CPU-CHARGE
-----
    
```

Continuing with the Extended Charge Example, using the panel below we indicated all MBJ ORD records' CPUID field should be tested to determine if:

- CPU ID = 'A': Then, multiply the calculated charge units by a factor of 1.00 or 100%
- CPU ID = 'B': Then multiply the calculated charge units by a factor of 5.308 for 530.8%

Thereby, normalizing the charge unit's calculation.

```

USERID          CA PMA Chargeback          MM/DD/YY HH:MM:SS
--            +--- CBCELMN ----- Normalizer Entry -----+
                Panel Exit Help
                -----
                Type information. Then select an action.
                -----
                Version . : PROD
                ORD Type . : MBJ
                Normalizer : SYSTEM
                -----
                Cmd Qualifier          More: - + ____ Row 0000 of 0000
                @CPUIDA_____          100_____
                @CPUIDB_____          530.8_____
                _____
                _____
                F2=Xref F5=Save F6=Delete F7=Bkwd F8=Fwd F11=Expand
                -----
                Command ==>
                F1=Help F3=Exit F4=Prompt F9=Command F10=Action Bar F12=Cancel PA1=Susp
    
```

We must now define the normalizer's qualifiers, @CPUIDA and @CPUIDB. Example 4 in Example 4: Qualifying a Normalizer shows you how to do this.

## Other Examples

### Charging a Flat Rate

You can charge a flat charge, or define a surcharge for a resource by specifying **\*ONE\*** in the Charge Unit field and providing a default rate, as shown on the panel below. Then use our charge algorithm (charge unit \* rate = charge element):

**\*ONE\* \* 5.00 = SURCHARGE**

The **\*ONE\*** makes the charge unit's value equal to one. It is then multiplied by the default rate. So, using the panel below, each MBJ ORD record generates a surcharge of 5.00.

```

USERID          CA PMA Chargeback          MM/DD/YY HH:MM:SS
--  Acctdefs  Cbdefs  Query  Data  Period  Options  Exit  Help
+-- CBCELME  ----- Charge Elements Entry -----+
|   Panel  Exit  Help
|-----|
|   Type information. Then select an action.
|
|   Version . . . : PROD
|   ORD Type . . . : MBJ
|   Charge Element : SURCHARGE_____
|
|   Charge Unit . . *ONE*_____
|   Normalizer . . . _____
|   Default Rate . . 5.00000_____
|   Maximum Charge . _____
|   Minimum Charge . _____
|
|   F5=Save  F6=Delete  F7=Unit  F8=Norm  F11=Rate
+-----+

Command ==> _____
F1=Help  F3=Exit  F4=Prompt  F9=Command  F10=Action Bar  F12=Cancel  PA1=Susp
    
```

## Bringing in Preexisting Charges

CA PMA Chargeback allows you to bring in preexisting charges from CA JARS, CA NETMAN, CA JASPER, and VS CHARGE.

In other words, you create a charge element that has the **same** name as a field that exists in an ORD. Then enter the same field name for the charge unit with a rate of 1.00. The **key** is the fact that the *charge element* name is the same name as the ORD field name.

The panel below shows you how to do this.

```

USERID          CA PMA Chargeback          MM/DD/YY HH:MM:SS
--  Acctdefs  Cbdefs  Query  Data  Period  Options  Exit  Help
+-- CBCELME ----- Charge Elements Entry -----+
| Panel  Exit  Help |
|-----|
| Type information. Then select an action. |
| Version . . . : PROD |
| ORD Type . . . : MBJ |
| Charge Element : PROCESSOR-CHARGE |
| Charge Unit . . PROCESSOR_CHARGE |
| Normalizer . . . |
| Default Rate . . 1.00000 |
| Maximum Charge . |
| Minimum Charge . |
|-----|
| F5=Save  F6=Delete  F7=Unit  F8=Norm  F11=Rate |
+-----+

Command ==>
F1=Help  F3=Exit  F4=Prompt  F9=Command  F10=Action Bar  F12=Cancel  PA1=Susp

```

**Caution** Do not press F7 (Unit) or F8 (Norm), because these functions will override the rate structure being imported.

## Defining Charge Units, Normalizers, & Qualifiers Directly

You have seen the usage of Charge Units, Normalizers, and Qualifiers as a part of the Charge Element definition. There is a need, especially during the initial implementation of the system, for direct entry of Charge Units, Normalizers, and Qualifiers **external** to the Charge Element definition.

Unit, Normalizer, and Qualifier definition functions allow this to happen, by enabling you to directly enter Units, Normalizers, and Qualifiers without regard for their use in Charge Elements. In the case of Qualifiers, you do **not** provide a Charge Element name on the Qualifiers primary panel shown in Qualifier Entry Panel.

The screen logic follows that of a Primary panel, followed by List, Expanded List, Entry, Expanded Entry panels.

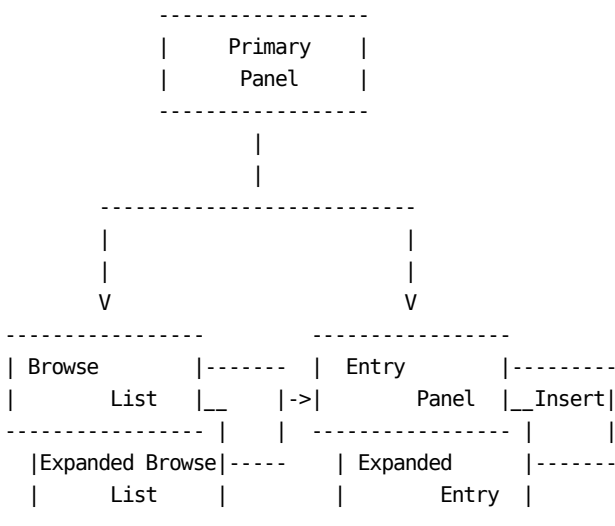

## Charge Units Panels

The Charge Units panel set allows you to create or define complex charge units directly. That is, without using the Charge Elements option.

The following panels make up the Charge Units panel set:

- Charge Units primary panel
- Charge Units List panel
- Expanded Charge Units List panel
- Charge Units Entry panel
- Charge Units Entry Insert panel
- Expanded Charge Units Entry panel

**Note:** Protected display field areas are preceded by a colon (:).

## Charge Units Primary Panel

The Charge Units Primary panel is used for creating, examining or modifying Charge Units.

```

USERID          CA PMA Chargeback          MM/DD/YY HH:MM:SS
--  Acctdefs  Cbdefs  Query  Data  Period  Options  Exit  Help
+-- CBCUNIP ----- Charge Units -----+
|   Panel  Exit  Help  |
|-----|
| Type information. Then select an action. |
| Version . . . : PROD                    |
| ORD Type . . . : ____                   |
| Charge Unit . . : _____            |
| F2=Create  F11=Browse                   |
+-----+

This panel associates an ORD record type, as defined by
the CA PMA Chargeback Administrator, with Charge Units

Command ==> _____
F1=Help  F3=Exit  F4=Prompt  F9=Command  F10=Action Bar  F12=Cancel  PA1=Susp
    
```

On the next page is a description of the Charge Units primary panel.

### Access

The Charge Units primary panel appears when one of these events occurs:

- You type CU in the fast path area of the Primary Panel's action bar.
- You select Cbdefs on the action bar and then choose Charge Units on the Cbdefs pull-down.
- You return from the Charge Units List or Entry panel.

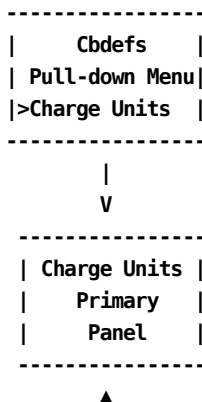

```

      |
      |-----|
      | Charge Units |
      |   List   |
      |>F3      |
      |-----|
      |   Entry   |
      |>F3      |
      |-----|

```

### Input

The Charge Units primary panel contains the following input fields:

#### ORD Type

The three-character name of the output record identifier for which you want to define, view or modify a charge unit.

When using F11=Browse: if you do not know the ORD Type name, enter the SQL wildcard character %. This provides you with a list of all ORD Types meeting the qualifier you specify in the next field. By entering a % at both the ORD Type and Charge Unit input fields you can get a list of all defined ORDs and Qualifiers.

**Note:** If you enter an ORD Type that is not currently defined to the CA PMA Chargeback database, you receive an informational message. You will need to speak to the DataManager and CA PMA Chargeback Administrators to arrange for its definition.

#### Charge Unit

The name of a complex charge unit for which you want to bill. A Charge Unit can be up to 16 alphanumeric characters in length and must be preceded by the @ symbol.

### Pathways

#### F2

**(Create)** Takes you to the Charge Unit Entry panel (page Charge Units Entry Panel).

#### F11

**(Browse)** Takes you to the Charge Unit List panel (page Charge Units List Panel).

## Charge Units List Panel

The Charge Units List panel displays a list of all currently defined charge units meeting the criteria specified on the Charge Units primary panel. The search criteria are redisplayed as protected fields. The following panel shows all Charge Units, currently defined for ORD type MBJ.

```

USERID          CA PMA Chargeback          MM/DD/YY HH:MM:SS
---            +--+ CBCUNIL ----- Charge Units List -----+
                Panel Exit Help
                -----
                Select charge unit name. Then Enter.
                Version . . . : PROD
                ORD Type . . . : MBJ
                Charge Unit : %
                More: - + ____ Row 0001 of 0004
                ORD Charge Unit
                - MBJ @CPUIDA
                - MBJ @CPUIDB
                - MBJ @DISK-CHARGE
                - MBJ @IO-COUNT
                Enter F7=Bkwd F8=Fwd F11=Expand
                +-----+
Command ==>
F1=Help F3=Exit F4=Prompt F9=Command F10=Action Bar F12=Cancel PA1=Susp
    
```

The following is a description of the Charge Units List panel.

### Access

The Charge Units List panel appears when one of these events occurs:

- You press **F11** (Browse) on the Charge Units primary panel shown in Charge Units Primary Panel.
- You return from the Expanded Charge Units List panel.

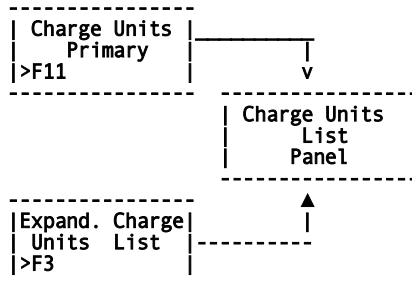

**Scrolling**

F7 and F8 let you scroll backward and forward through the Charge Units selection list, or use the scroll bar as described on page Sample List Panel.

**Pathways****Enter**

By placing the cursor next to the required item, and pressing Enter, a selection is made.

**F11**

**(Expand)** Gives you an **expanded** (eight-line display) view of the Charge Units List panel.

**Expanded Charge Units List Panel**

The following panel appears when you press F11 (Expand) on the Charge Units List panel shown on Charge Units List Panel. The only difference between the two panels is the Version, ORD Type, and Charge Units protected fields are not displayed. This allows you to view more information on a single panel. The Expanded List panel functions in the same way as the list panel from which it was called.

```

USERID          CA PMA Chargeback          MM/DD/YY HH:MM:SS
--  Acctdefs  Cbdefs  Query Data Period  Options  Exit  Help
+-- CBCUNIX  ----- Expanded Units List -----+
|   Panel  Exit  Help
|-----|
| Select charge unit name. Then Enter.
|
| More: - + ____ Row 0001 of 0004
|
| ORD Charge Unit
|
| _ MBJ @CPUIDA
| _ MBJ @CPUIDB
| _ MBJ @DISK-CHARGE
| _ MBJ @IO-COUNT
|
|
|
| Enter  F7=Bkwd  F8=Fwd
+-----+
Command ==>
F1=Help  F3=Exit  F4=Prompt  F9=Command  F10=Action Bar  F12=Cancel  PA1=Susp

```

## Charge Units Entry Panel

You only select this panel, when you are defining a **complex** charge unit. A complex charge unit is a user-defined entity (indicated by the @ prefix) that is a computed item. The algorithm for @CPU-TIME is shown below.

```

USERID          CA PMA Chargeback          MM/DD/YY HH:MM:SS
--- Acctdefs  Cbdefs  Query  Data  Period  Options  Exit  Help
+-- CBCUNIE ----- Charge Units Entry -----+
| Panel  Exit  Help |
|-----|
| Type information and save. Then select an action. |
| Version . . . : PROD |
| ORD Type . . . : MBS |
| Charge Unit : @CPU-TIME |
|-----|
| More: - + _____ Row 0000 of 0000 |
| Cmd  ORD Field/@Unit  Aop  Field/Constant  Aop |
| SRB-TIME_____ *  '.5'_____ + |
| TCB-TIME_____ *  '.5'_____ - |
| _____ - _____ - |
| _____ - _____ - |
|-----|
| F2=Xref F5=Save F6=Delete F7=Bkwd F8=Fwd F11=Expand |
+-----+

Command ==> _____
F1=Help F3=Exit F4=Prompt F9=Command F10=Action Bar F12=Cancel PA1=Susp
    
```

**Note:** The first time this panel appears, you are in **insert** mode; no lines appear under the Cmd column, the scroll bar does not show a row count, and the only active panel function keys are F2, F5, and F11. When you press F5 (Save), a message appears telling you the **insert** is successful. At this point, you are in **update** mode. The panel scroll bar provides a row count, the Cmd column is active (lines appear under the column) and **all** panel function keys are active. Pressing F5 (Save) displays a message stating the **update** was successful.

A description of the Charge Units Entry panel follows.

### Access

The Charge Units Entry panel appears when one of these events occurs:

- You press **F2** (Create) on the Charge Units Primary panel shown in Charge Units Primary Panel.
- You return from the Expanded Units Entry panel.

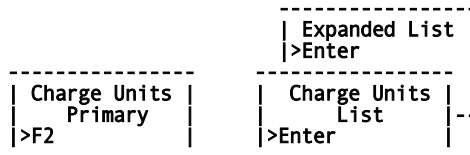

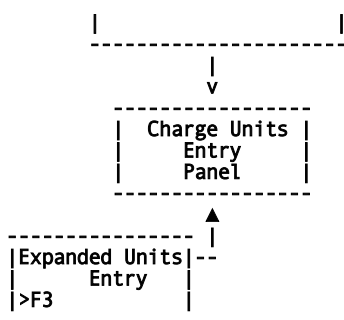

### Scrolling

F7 and F8 let you scroll backward and forward through the charge unit entries. You can also use the scroll bar. to move through the charge unit entries.

### Input

The Charge Units Entry panel contains the following input fields:

#### Cmd

Use this column to specify commands. Valid commands include:

D Deletes lines from the calculation.

I Inserts lines into the calculation using the Unit Insert (CBCUNII) pop-up window. Refer to page Sample Entry Panel Insert Pop-Up Window for information on how to use the insert window.

#### ORD Field/@Unit

Can refer to either a valid field defined in the ORD or another user-defined charge unit (indicated by the @ prefix) applying to the same ORD. Thus, complex calculations can be performed in an hierarchical manner.

**Note:** Sequencing of items is critical.

#### Aop

(Arithmetic operator): + (addition), - (subtraction), \* (multiplication), / (division).

#### Field/Constant

List any constants or ORD fields used in the definition of a complex charge unit.

**Note:** When specifying constants, they **must** be enclosed in single quotes. For example, '.5' as shown on the preceding panel.

#### Aop

(Arithmetic operator) a **link** used to continue the calculation: + (addition), - (subtraction), \* (multiplication), / (division).

### Actions

#### F2=Xref

Gives you a cross-referenced listing of other complex units and charge elements that reference this complex unit.

#### F5=Save

Lets you add and update rows in the Charge Units table.

#### F6=Delete

Lets you delete all entries from the Charge Units table.

#### F7=Bkwd

Lets you scroll backward through the table.

**F8=Fwd**

Lets you scroll forward through the table.

**F11=Expand**

Presents you with an eight-line display of the Charge Units Entry.

**Expanded Units Entry Panel**

The following panel appears when you press F11 (Expand) on the Charge Units Entry panel. The only difference between the Charge Unit Entry and Expanded Entry panels is the Version, ORD Type, and Charge Unit protected fields are not displayed. This allows you to view more information on a single panel. The Expanded Entry panel functions in the same way as the Entry panel from which it was called.

```

USERID                               CA PMA Chargeback                MM/DD/YY HH:MM:SS
---  Acctdefs  Cbdefs  Query  Data  Period  Options  Exit  Help
+--  CBCUNIV  -----  Expanded Units Entry -----+
      Panel  Exit  Help
      -----
      Type information and save. Or Delete.

      More: - + _____ Row 0000 of 0000
      Cmd  ORD Field/@Unit  Aop  Field/Constant  Aop
      SRB-TIME_____ *  '.5'_____ +
      TCB-TIME_____ *  '.5'_____ -
      _____ - _____ -
      _____ - _____ -
      _____ - _____ -
      _____ - _____ -
      _____ - _____ -
      _____ - _____ -
      F2=Xref  F5=Save  F6=Delete  F7=Bkwd  F8=Fwd
+-----+

Command ==> _____
F1=Help  F3=Exit  F4=Prompt  F9=Command  F10=Action Bar  F12=Cancel  PA1=Susp
    
```

## Normalizer Panels

The Normalizer panel set allows you to create or define normalizers directly. That is, without using the Charge Elements option.

The following panels make up the Normalizer panel set:

- Normalizers primary panel
- Normalizer List panel
- Expanded Normalizer List panel
- Normalizer Entry panel
- Normalize Entry Insert panel
- Expanded Normalizer Entry panel

**Note:** Protected display field areas are preceded by a colon (:).

## Normalizer Primary Panel

The Normalizer Primary panel is used for creating, examining or modifying Normalizers.

```

USERID          CA PMA Chargeback          MM/DD/YY HH:MM:SS
--- Acctdefs  Cbdefs  Query  Data  Period  Options  Exit  Help
+-- CBCNRMP ----- Normalizers -----+
| Panel  Exit  Help |
|-----|
| Type information. Then select an action. |
|-----|
| Version . : PROD |
| ORD Type . . MBJ |
| Normalizer . SYSTEM |
|-----|
| F2=Create  F11=Browse |
+-----+

Command ==> _____
F1=Help  F3=Exit  F4=Prompt  F9=Command  F10=Action Bar  F12=Cancel  PA1=Susp
    
```

A description of the Normalizer primary panel follows.

### Access

The Normalizers primary panel appears when one of these events occurs:

- You type CN in the fast path area of the Primary Panel's action bar.
- You select Cbdefs on the action bar and then choose Normalizer on the Cbdefs pull-down.
- You return from the Normalizer List or Entry panel.

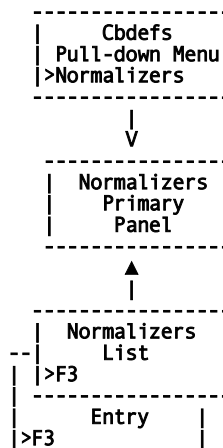

-----

### Input

The Normalizers primary panel contains the following input fields:

#### ORD Type

The three-character name of the output record identifier for which you want to define, view or modify a normalizer.

When using F11=Browse: if you do not know the ORD Type name, enter the SQL wildcard character %. This provides you with a list of all ORD Types meeting the qualifier you specify in the next field. By entering a % at both the ORD Type and Normalizer prompts you can get a list of all defined ORDs and Normalizers.

**Note:** If you enter an ORD Type that is not currently defined to the DataManager database, you receive an informational message. You will need to speak to the DataManager and DataManager Administrators to arrange for its definition.

#### Normalizer

The name of a normalizer you want applied to charge unit's calculation. A Normalizer name can be up to 16 alphanumeric characters in length.

### Pathways

#### F2

**(Create)** Takes you to the Normalizer Entry panel (Section Normalizer Entry Panel).

#### F11

**(Browse)** Takes you to the Normalizer List panel (Section Normalizer List Panel).

## Normalizer List Panel

The Normalizer List panel displays a list of all currently defined normalizers meeting the criteria specified on the Normalizer primary panel. The search criteria are redisplayed as protected fields.

```

USERID                               CA PMA Chargeback           MM/DD/YY HH:MM:SS
--  Acctdefs  Cbdefs  Query  Data  Period  Options  Exit  Help
+-- CBCNRML  ----- Normalizer List -----+
      Panel  Exit  Help
-----+-----
      Select a normalizer name. Then Enter.

      Version . : PROD
      ORD Type . : MBJ
      Normalizer : SYSTEM

      ORD Normalizer           More: - + ____ Row 0001 of 0001
      _ MBJ SYSTEM
      -
      -
      -
      Enter  F7=Bkwd  F8=Fwd  F11=Expand
+-----+-----

Command ==>
F1=Help  F3=Exit  F4=Prompt  F9=Command  F10=Action Bar  F12=Cancel  PA1=Susp
  
```

The following is a description of the Charge Units List panel.

### Access

The Normalizer List panel appears when one of these events occurs:

- You press **F11** (Browse) on the Normalizers primary panel shown in Normalizer Primary Panel.
- You return from the Expanded Normalizer List panel.

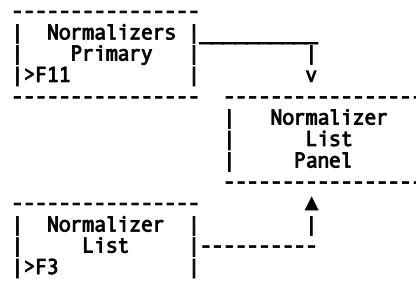

**Scrolling**

F7 and F8 let you scroll backward and forward through the Normalizer selection list, or use the scroll bar as described on page Sample List Panel.

**Pathways**

**Enter**

By placing the cursor next to the required item, and pressing Enter, a selection is made.

**F11**

**(Expand)** Gives you an **expanded** (eight-line display) view of the Normalizer List panel.

**Expanded Normalizer List Panel**

The following panel appears when you press F11 (Expand) on the Normalizer List panel shown in Normalizer List Panel. The only difference between the two panels is the Version, ORD Type, and Normalizer protected fields are not displayed. This allows you to view more information on a single panel. The Expanded List panel functions in the same way as the List panel from which it was called.

```

USERID          CA PMA Chargeback          MM/DD/YY HH:MM:SS
--  Acctdefs  Cbdefs  Query  Data  Period  Options  Exit  Help
+-- CBCNRMX  ----- Expanded Normalizer List -----+
      Panel  Exit  Help
-----
      Select a normalizer name. Then Enter.
                                     More: - + ____ Row 0001 of 0001
      ORD Normalizer
      _ MBJ SYSTEM
      -
      -
      -
      -
      -
      -
      -
      -
      Enter  F7=Bkwd  F8=Fwd
+-----+

Command ==>
F1=Help  F3=Exit  F4=Prompt  F9=Command  F10=Action Bar  F12=Cancel  PA1=Susp
    
```

## Normalizer Entry Panel

You use this panel to define or modify a normalizer you named on the Normalizer Primary panel (section Normalizer Primary Panel). Normalizers are **only** associated with charge units and are weighting factors (percentages) that are applied to a **charge unit's** calculated value **before** rates are applied. In the example below, we are providing a definition for a normalizer called SYSTEM.

```

USERID          CA PMA Chargeback          MM/DD/YY HH:MM:SS
--- Acctdefs Cbdefs Query Data Period Options Exit Help
+-- CBCNRME ----- Normalizer Entry -----+
| Panel Exit Help |
|-----|
| Type information. Then select an action. |
|-----|
| Version . : PROD |
| ORD Type . : MBJ |
| Normalizer : SYSTEM |
|-----|
| Cmd Qualifier          More: - + ____ Row 0001 of 0002 |
|-----|
| @CPUIDA _____ 100 |
| @CPUIDB _____ 530.8 |
|-----|
| F2=Xref F5=Save F6=Delete F7=Bkwd F8=Fwd F11=Expand |
+-----+

Command ==>
F1=Help F3=Exit F4=Prompt F9=Command F10=Action Bar F12=Cancel PA1=Susp
    
```

**Note:** The first time this panel appears, you are in **insert** mode; no lines appear under the Cmd column, the scroll bar does not show a row count, and the only active panel function keys are F2, F5, and F11. When you press F5 (Save), a message appears telling you the **insert** is successful. At this point, you are in **update** mode. The panel scroll bar provides a row count, the Cmd column is active (lines appear under the column) and **all** panel function keys are active. Pressing F5 (Save) displays a message stating the **update** was successful.

A description of the Normalizer Entry panel follows.

### Access

The Normalizer Entry panel appears when one of these events occurs:

- You press **F2** (Create) on the Normalizer primary panel shown in Normalizer Primary Panel.
- You make a selection on the Normalizer List or Expanded list panels.
- You return from the Expanded Normalizer Entry panel.

```

-----
| Expanded List |
|>Enter      |
|-----|
    
```

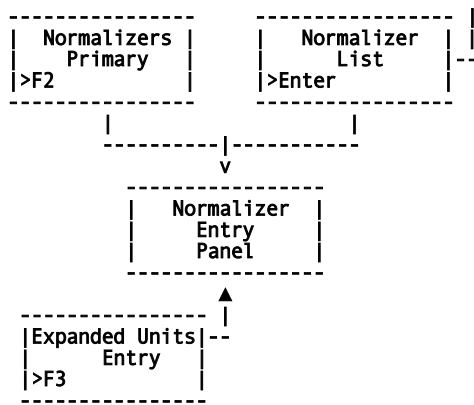

### Scrolling

F7 and F8 let you scroll backward and forward through the normalizer entries. You can also use the scroll bar, to move through the normalizer entries.

### Input

The Normalizer Entry panel contains the following input fields:

#### Cmd

Use this column to specify commands. Valid commands include:

D Deletes lines from the calculation.

I Inserts lines into the calculation using the Normalizer Insert (CBCNRM) pop-up window. Refer to page Sample Entry Panel Insert Pop-Up Window on how to use the insert window.

#### Qualifier

The user-defined name of a conditional test that is applied to a charge unit.

#### Percentage

The weighting factor (**a percentage**) you want applied to a charge unit, based on the qualification tests you define. For example, 20%.

To increase a value by 20%, enter 120.

To decrease a value by 20%, enter 80.

The precision for this field is 99999999V99999999.

### Actions

#### F2=Xref

Gives you a cross-referenced listing of all charge elements that reference this normalizer.

#### F5=Save

Lets you save the qualification(s).

#### F6=Delete

Lets you delete the qualification(s).

#### F7=Bkwd

Lets you scroll backwards through the panel.

#### F8=Fwd

Lets you scroll forward through the panel.

#### F11=Expand

Presents you with an eight-line display of the Normalizer List panel.

### Expanded Normalizer Entry Panel

The following panel appears when you press F11 (Expand) on the Normalizer Entry panel. The only difference between the Normalizer Entry and Expanded Entry panels is the Version, ORD Type, and Normalizer protected fields are not displayed. This allows you to view more information on a single panel. The Expanded Entry panel functions in the same way as the Entry panel from which it was called.

```

USERID          CA PMA Chargeback          MM/DD/YY HH:MM:SS
--  Acctdefs  Cbdefs  Query  Data  Period  Options  Exit  Help
+-- CBCNRMV ----- Expanded Normalizer Entry -----+
      Panel  Exit  Help
+-----+
| Type information. Then select an action.                |
|                                                         |
| Cmd Qualifier          More: - + ____ Row 0001 of 0001 |
|                       Percentage                       |
|  _ @TEST2_____          200                          |
|  - _____          _____                       |
|  - _____          _____                       |
|  - _____          _____                       |
|  - _____          _____                       |
|  - _____          _____                       |
|  - _____          _____                       |
|  - _____          _____                       |
|                                                         |
| F2=Xref  F5=Save  F6=Delete  F7=Bkwd  F8=Fwd          |
+-----+
Command ==> _____
F1=Help  F3=Exit  F4=Prompt  F9=Command  F10=Action Bar  F12=Cancel  PA1=Susp
    
```

### Qualifier Panels

A qualifier establishes a conditional test resulting in a true or false condition. Qualifiers can be used with charge units, modifiers, normalizers, and in the definition of conditional rates. The following panel set is used to define qualifiers directly.

- Qualifiers primary panel
- Qualifiers List panel
- Qualifiers Expanded List panel
- Qualifiers Entry panel
- Qualifiers Entry Insert panel
- Qualifiers Expanded Entry panel

**Note:** During processing, ORD-specific qualifiers are always applied **before** global qualifiers (those with an ORD type of ALL).

Protected display field areas are preceded by a colon (:).



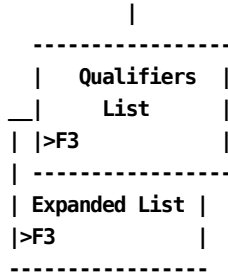

**Input**

The Qualifiers primary panel contains the following input fields:

**ORD Type**

The three-character name of the output record identifier for which you want to define, view or modify a qualifier.

When using F11=Browse: if you do not know the ORD Type name, you can enter the SQL wildcard character %. This provides you with a list of all ORD Types that match the qualifier you specify in the next field. By entering a % at both the ORD Type and Qualifier prompts you can get a list of all defined ORDs and Qualifiers.

**Note:** If you enter an ORD Type that is not currently defined to the CA PMA Chargeback database, you receive an informational message. You need to speak to the DataManager and CA PMA Chargeback Administrator to arrange for its definition.

**Qualifier**

The name of a conditional test you want applied globally or associated with the contents of a specific ORD type. A qualifier can be up to 16 alphanumeric characters in length and must be preceded by the @ symbol.

**Pathways**

**F2**

**(Create)** Takes you to the Qualifier Entry panel (section Qualifier Entry Panel).

**F11**

**(Browse)** Takes you to the Qualifier List panel (section Qualifier List Panel).



**Scrolling**

F7 and F8 let you scroll backward and forward through the Qualifier selection list, or use the scroll bar as described on page Sample List Panel.

**Pathways**

**Enter**

By placing the cursor next to the required item, and pressing Enter, a selection is made.

**F11**

**(Expand)** Gives you an **expanded** (eight-line display) view of the Qualifier List panel.

**Expanded Qualifier List Panel**

The following panel appears when you press F11 (Expand) on the Qualifiers List panel shown in Qualifier List Panel. The only difference between the two panels is the Version, ORD Type, and Qualifier protected fields are not displayed. This allows you to view more information on a single panel. The Expanded List panel functions in the same way as the list panel from which it was called.

```
USERID          CA PMA Chargeback          MM/DD/YY HH:MM:SS
--  Acctdefs  Cbdefs  Query Data Period  Options  Exit  Help
+-- CBCQALX ----- Qualifier List -----+
|      Panel  Exit  Help
|-----+
| Select qualifier name. Then Enter.
|
|          More: - + ____ Row 0001 of 0004
| ORD Qualifier
| - MBJ @SHIFT1
| - MBJ @SHIFT2
| - MBJ @SHIFT3
| - MBJ @WEEKEND
|
|
| Enter  F7=Bkwd  F8=Fwd
+-----+
Command ==>
F1=Help  F3=Exit  F4=Prompt  F9=Command  F10=Action Bar  F12=Cancel  PA1=Susp
```

## Qualifier Entry Panel

The Qualifiers Entry panel is used to define the range of a qualifier.

**Note:** You can create global qualifiers by specifying an ORD Type of **ALL**. This means for those conditions you select, you only have to define the qualifier once, rather than defining it over and over for each ORD type. This is very efficient when defining qualifiers for conditions such as SHIFT.

```

USERID          CA PMA Chargeback          MM/DD/YY HH:MM:SS
---  Acctdefs  Cbdefs  Query  Data  Period  Options  Exit  Help
+--  CBCQALE  -----  Qualifier Entry -----+
      Panel  Exit  Help
      -----
      Type information and save. Then select an action.
      -----
      Version . : PROD
      ORD Type . : MBJ
      Qualifier : @SHIFT1_____

      ORD          More: - + _____ Row 0001 of 0002
      Cmd  Field/@Qualifier  Rop  Field/Constant  Lop
      START-HHMM _____ >= '0800' _____ and
      START-HHMM _____ <  '1600' _____  ___
      _____          _____          _____
      _____          _____          _____

      F2=Xref F5=Save F6=Delete F7=Bkwd F8=Fwd F11=Expand
+-----+
Command ==> _____
F1=Help F3=Exit F4=Prompt F9=Command F10=Action Bar F12=Cancel PA1=Susp
    
```

**Note:** The first time this panel appears, you are in **insert** mode; no lines appear under the Cmd column, the scroll bar does not show a row count, and the only active panel function keys are F2, F5, and F11. When you press F5 (Save), a message appears telling you the **insert** is successful. At this point, you are in **update** mode. The panel scroll bar provides a row count, the Cmd column is active (lines appear under the column) and **all** panel function keys are active. Pressing F5 (Save) displays a message stating the **update** was successful.

On the next page is a description of the Qualifier Entry panel.

### Access

The Qualifier Entry panel appears when one of these events occurs:

- You press **F2** (Create) on the Qualifiers Primary panel shown in Qualifiers Primary Panel.
- You make a selection on the Qualifier List or Expanded List panel.

You return from the Expanded Qualifier Entry panel shown in Qualifier Entry Panel.

```

| Expanded List |
|>Enter       |
    
```

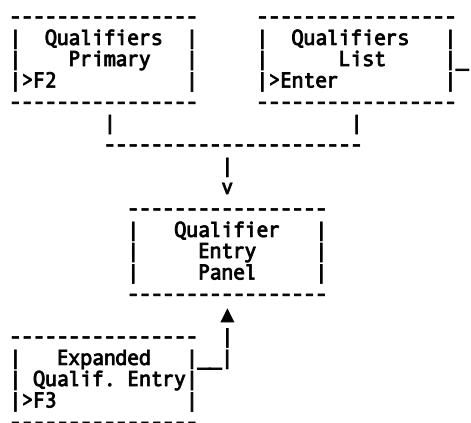

### Scrolling

F7 and F8 let you scroll backward and forward through the Qualifiers definition list. You can also use the scroll bar to move through the entries.

### Input

The following Qualifier Entry panel fields are available for input:

#### Cmd

This column is used to specify commands. Valid commands include:

D (Delete) Used to delete individual lines from the conditional test.

I (Insert) Used to insert lines into the conditional test using the Qualifier Insert (CBCQALI) pop-up window. Refer to page Sample Entry Panel Insert Pop-Up Window for information on how to use the insert window.

#### ORD Element/@Qualifier

You use this column to identify the ORD Element or Qualifier name to be used. The contents of this Element Name is compared with the Field/Constant identifier provided in the Field/Constant column. Defines the qualifier named in the protected display field at the top of the panel.

**Note:** Also, a qualifier can refer to other qualifiers. Nesting is permitted to any level.

#### Rop

Relational operator: acceptable entries include: < (less than), > (greater than), = (equal), or combinations, such as =< (equal to or less than) and &x'5f. = (not equal).

#### Field/Constant

Defines the desired value, either another ORD Element or a specific result, used in the comparison with the ORD Element/@Qualifier.

#### Lop

(Logical operator) acceptable operators are: **and** and **or**.

### Actions

#### F2=Xref

Gives you a cross-referenced listing of all charge elements, other qualifiers, modifiers, and so forth that reference this qualifier.

#### F5=Save

Lets you add and update rows in the table.

#### F6=Delete

Lets you delete rows from the table.

**F7=Bkwd**

Lets you scroll backwards through the table.

**F8=Fwd**

Lets you scroll forward through the table.

**F11=Expand**

Gives you an eight-line display of the Qualifier Entry panel.

**Expanded Qualifier Entry Panel**

The following panel appears when you press F11 (Expand) on the Qualifier Entry panel shown in Qualifier Entry Panel. The only difference between the two panels is the Version, ORD Type, and Qualifier protected fields are not displayed. This allows you to view more information on a single panel. The Expanded Qualifier Entry panel functions in the same way as the Entry panel from which it was called.

```

USERID                               CA PMA Chargeback                MM/DD/YY HH:MM:SS
---  Acctdefs  Cbdefs  Query  Data  Period  Options  Exit  Help
+--  CBCQALV  ----  Expanded Qualifier Entry  -----+
      Panel  Exit  Help
      -----
      Type information and save. Then select an action.
      ORD                               More: - + ____ Row 0001 of 0002
      Cmd Field/@Qualifier  Rop Field/Constant  Lop
      -  START-HHMM_____ >= '0800'_____ and
      -  START-HHMM_____ <  '1600'_____  ___
      -  _____  ___  _____  ___
      -  _____  ___  _____  ___
      -  _____  ___  _____  ___
      -  _____  ___  _____  ___
      -  _____  ___  _____  ___
      F2=Xref  F5=Save  F6=Delete  F7=Bkwd  F8=Fwd
+-----+

Command ==> _____
F1=Help  F3=Exit  F4=Prompt  F9=Command  F10=Action Bar  F12=Cancel  PA1=Susp
    
```

## Defining Modifiers

Modifiers are the CA PMA Chargeback method of enabling you to modify, either globally or by a specific ORD Type, charge elements calculated charge based on user-defined qualifiers. Examples include adjusting charges for:

- Holidays
- Weekends
- A specific class or priority
- A specific department

These conditions can obviously be coded within the algorithm for a charge element, but being more general in nature, they warrant specific handling. Modifiers also reduce the number of qualifiers and qualified rates required. When charges are applied, the charge is computed and a record is written to the CCCTAB. At the same time, an additional **modified** record is also written to the CCCTAB. This lets you maintain an effective audit trail.

**Note:** To create a global modifier, specify an ORD Type of **ALL** on the Modifiers primary panel. This means for those conditions specified, you only have to define the modifier once, rather than defining it over and over for each ORD type. This is very efficient when defining modifiers that relate to conditions such as SHIFT and WEEKEND.

The algorithm for applying a modifier is:

```

-----
Charge Element * |Modifier| = Modified Charge Element
-----

```

The Modifiers panel set is made up of the following panels:

- Modifiers primary panel
- Modifiers List panel
- Expanded Modifiers List panel
- Modifiers Entry panel

**Note:** Protected display field areas are preceded by a colon (:).

## Modifiers Primary Panel

The Modifiers primary panel is used for creating, examining or updating a modifier. A modifier name can be up to 16 alphanumeric characters, while the modifier itself can be either an amount or a percentage that is applied to the charge element **after** it has been calculated. Modifiers generate a **modified** charge element record, thereby ensuring that the original charge element record maintains its integrity. This allows you to maintain an effective audit trail.

```

USERID          CA PMA Chargeback          MM/DD/YY HH:MM:SS
---            +--- CBCMODP -----+
|              Panel Exit Help          |
|-----|
|              Type information. Then select an action.
|
|              Version . . : PROD
|              ORD type . . ____
|              Modifier . . _____
|
|              F2=Create  F11=Browse
+-----+

This panel associates an ORD version, as defined by
the CA PMA Chargeback Administrator, with a modifier.

Command ==> _____
F1=Help  F3=Exit  F4=Prompt  F9=Command  F10=Action Bar  F12=Cancel  PA1=Susp
    
```

**Note:** If you enter the SQL wildcard character % in the Modifier and ORD Type entry fields and then press F11 (Browse): you will see a list of all currently defined modifiers.

On the next page is a description of the Modifiers primary panel.

### Access

The Modifiers primary panel appears when one of these events occurs:

- You type CM in the fast path area of the CA PMA Chargeback Primary Panel's action bar.
- You choose Modifiers on the Cbdefs pull-down.
- You return from the Modifier List or Entry panel.

```

-----
|      Cbdefs      | _____
|      Pull-down   |         |
|>Modifiers      |         v
-----
    
```



## Modifier List Panel

The Modifier List panel displays a list of all currently defined modifiers that match the criteria specified on the Modifiers primary panel. The search criteria are redisplayed as protected fields. The following panel shows all modifiers, currently defined for DataManager Version PROD.

```

USERID          CA PMA Chargeback          MM/DD/YY HH:MM:SS
--- Acctdefs Cbdefs Query Data Period Options Exit Help
+-- CBCMODL ----- Modifier List -----+
|                                     |
|                                     |
| Select Modifier name. Then Enter. |
|                                     |
| Version . . : PROD                 |
| Modifier . . : %                    |
| Ordid. . . : %                      |
|                                     |
| ORD Modifier                       |
|                                     |
| _ MBJ CLASS                         |
| _ MBJ DEVELOPMENT                   |
| _ MBJ SHIFT                         |
|                                     |
|                                     |
| Enter F7=Bkwd F8=Fwd F11=Expand   |
+-----+-----+-----+-----+
Command ==>
F1=Help F3=Exit F4=Prompt F9=Command F10=Action Bar F12=Cancel PA1=Susp
    
```

The following is a description of the Modifiers List panel.

### Access

The Modifier List panel appears when one of these events occurs:

- You press **F11** (Browse) on the Modifiers primary panel shown in Modifiers Primary Panel.
- You return from the Expanded Modifier List panel using F3.

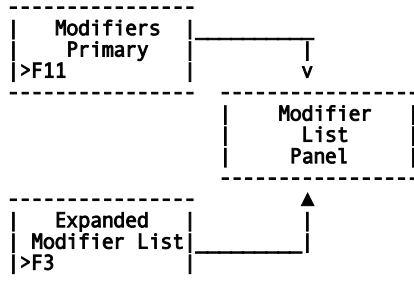

**Scrolling**

F7 and F8 let you scroll backward and forward through the Modifier selection list. You can also use the scroll bar to move through the list.

**Pathways****Enter**

By placing the cursor next to the required item, and pressing **Enter** you can go to the Modifier Entry panel (shown in Modifier Entry Panel) to examine and optionally update the item.

**F11**

**(Expand)** Provides you with an **expanded** (eight-line display) view of the Modifier List panel.

**Expanded Modifier List Panel**

The following panel appears when you press F11 (Expand) on the Modifiers List panel shown in Modifier List Panel. The only difference between the two panels is the Version and Modifier protected fields are not displayed. This allows you to view more information on a single panel. The Expanded List panel functions in the same way as the list panel from which it was called.

```

USERID          CA PMA Chargeback          MM/DD/YY HH:MM:SS
--            Acctdefs Cbdefs Query Data Period Options Exit Help
+-- CBCMODX ----- Expanded Modifier List -----+
|          Panel Exit Help
|-----|
| Select Modifier name. Then Enter.
|
|          More: - + ____ Row 0001 of 0004
|
|   ORD Modifier
|
|   - MBJ CLASS
|   - MBJ DEVELOPMENT
|   - MBJ SHIFT
|   - MBJ WEEKEND
|
|   -
|   -
|   -
|
|   Enter  F7=Bkwd  F8=Fwd
|-----|
+-----+

Command ==>
F1=Help  F3=Exit  F4=Prompt  F9=Command  F10=Action Bar  F12=Cancel  PA1=Susp

```

## Modifier Entry Panel

The Modifier Entry panel defines the criteria to be applied, as well as the modification to be made to the charge elements. The modification may be by:

- percentage
- amount

You can use a negative (-) amount for a discount and a positive (+) amount for a surcharge.

The algorithm for modifiers is:

```

      Modifier
Charge   WEEKEND
Element  -----
CPU-CHARGE * |-.10 | = Modified CPU-CHARGE
      -----
    
```

The following panel shows how to apply a 10 percent discount on all resources used on either a Saturday or a Sunday. The discount is applied without regard to Charge Element, Qualifier criteria or accounting level.

```

USERID          CA PMA Chargeback          MM/DD/YY HH:MM:SS
--            +--- CBCMODE -----+-----+
Panel Exit Help
-----+-----+
Version . . . : PROD      Modifier : WEEKEND
ORD Type . . . : MBJ

Element criteria . . _____
Qualifier criteria . _____
Modify Amount . . . -10.00000 or % P Exit on true Y
Qualifier . . . . . @WEEKEND _____
Sequence number . . 00001
DIVISION . . . . . _____
DEPARTMENT . . . . . _____
SECTION . . . . . _____
GROUP-ID . . . . . _____
TEAM . . . . . _____

F5=Save F6=Delete
-----+-----+

Command ==>
F1=Help F3=Exit F4=Prompt F9=Command F10=Action Bar F12=Cancel PA1=Susp
    
```

If you have not already created the qualifier you want associated with the modifier, you can now do so by invoking the Cbdefs pull-down and selecting Qualifiers.

Next is a description of the Modifier Entry panel.

### Access



**Exit on True (Required)**

Y(es) or N(o); if Y, after the first true condition is encountered, all further processing of modifiers is stopped. If N, processing continues with the next modifier sequence number. This process continues until a modifier is encountered that contains Exit on True=Y.

**Qualifier**

The qualifier name that defines the conditional test(s) that determine when the modifier is applied.

**Sequence Number**

Used to assign a **search order number** for the modifier you are defining on this panel. Sequence numbers determine the order in which rules are executed. See page Examples for a description of modifier rules.

**Note:** Assign sequence numbers in increments of 10. Doing so provides you with flexibility should you decide to add additional modifiers at a later date.

This example uses the following entry fields to indicate the accounting entities you want the modifier applied to (only defined accounting levels are displayed on the panel) the default is to apply the modifier globally:

**Division**

A specific user-defined group, or a qualifier containing a list of conditions that can be used to specify groups within this level.

**Department**

A specific user-defined group, or a qualifier containing a list of conditions that can be used to specify groups within this level.

**Section**

A specific user-defined group, or a qualifier containing a list of conditions that can be used to specify groups within this level.

**Group-id**

A specific user-defined group, or a qualifier containing a list of conditions that can be used to specify groups within this level.

**Team**

A specific user-defined group, or a qualifier containing a list of conditions that can be used to specify groups within this level.

**Actions**

**F5=Save**

Lets you save the Modifier entry.

**F6=Delete**

Lets you delete the modifier entry.

## Examples

The following entry fields are used as selection criteria for modifier processing:

- ORD Type specified on the Modifiers primary panel (see 1)
- Element criteria (see 2)
- Qualifier criteria (see 3)
- Structure (see 4)

Selection criteria testing starts at (1). Any records not meeting conditions (1) - (4) are rejected from modification at the point they fail.

*Sequence Number* (5) is used to specify the order in which modifier rules are executed. This is especially critical when Exit on true=N. A CCCTAB record meeting tests (1) through (6) will have a modified record generate. The **calculated** charge units and costs are modified to reflect the application of the modified amount (8). The record continues on to the next modifier test based on the remaining modifiers' Sequence Numbers. If at any point the record does not meet a criterion or conditional test, that modifier is not applied. If, on the other hand, it meets all the tests for another modifier, an additional *modified* CCCTAB record is generated. Processing continues in this manner until all records have been processed and all modifiers tested.

The processing flow is shown next.

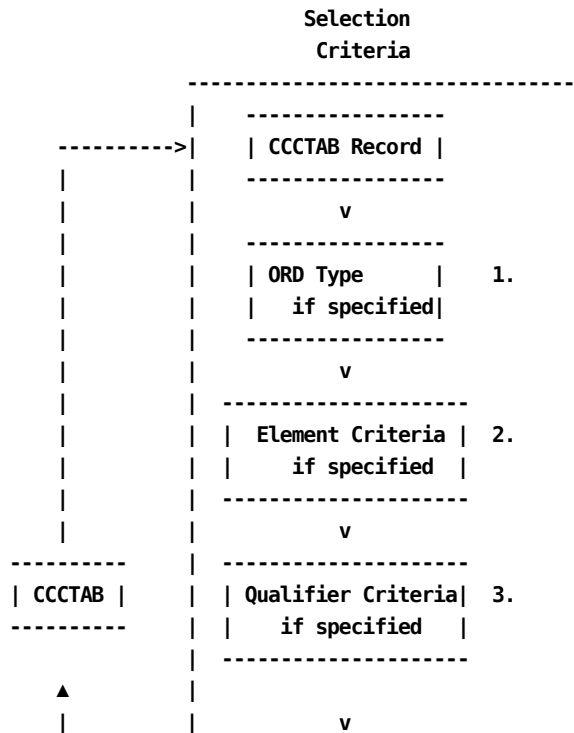

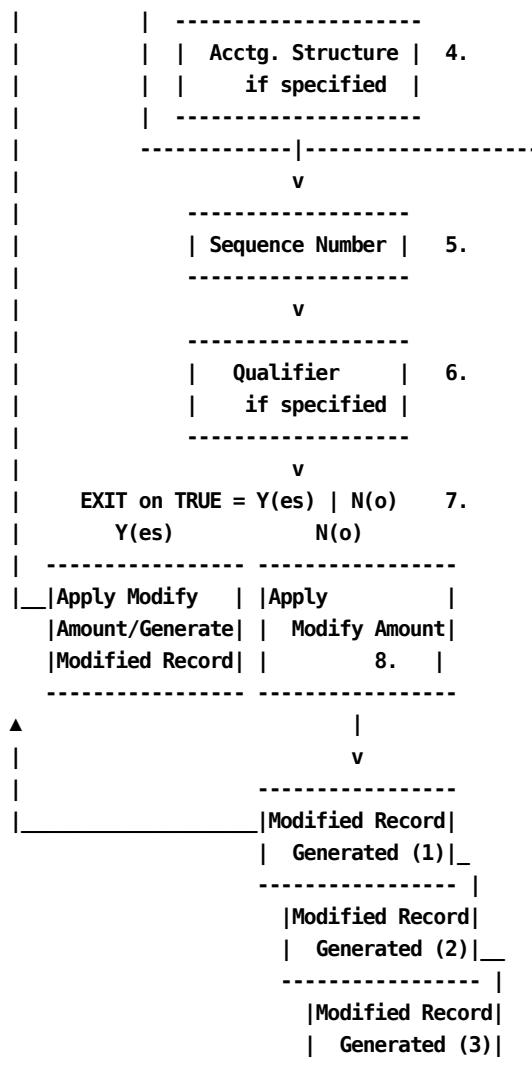

**Modifier Rules**

	Processing Order	Example 1 Modifier X	Example 2 Modifier Y	Example 3 Modifier Z
1.	ORD	MBJ	ALL	ALL
2.	Element Criteria	CPU-CHARGE		
3.	Qualifier Criteria			
4.	Structure	EAST		

	Processing Order	Example 1 Modifier X	Example 2 Modifier Y	Example 3 Modifier Z
5.	Sequence	100	200	300
6.	Qualifier	@WEEKEND		@SHIFT3
7.	Exit on True	Y	N	Y
8.	Modify Amount	+10%	-10%	-20%

Let us assume that shifts end at: 0800, 1600, and 2400 and we have the following records to be processed:

Record	ORD	Charge Element	Field1	Field2	Struct
1	MBJ	CPU-CHARGE	Saturday	2359	EAST
2	MBJ	IO-CHARGE	Monday	1200	EAST
3	MBJ	PRT-CHARGE	Monday	2359	North
4	MBJ	X-CHARGE	Thursday	1900	EAST

**Record 1** only has a type X modifier applied because it meets the qualifier @WEEKEND (this job ran on Saturday). Since EOT=T, further processing of modifiers stops here. A 10% surcharge is applied.

**Record 2** only meets modifier Y's rules: Structure = EAST. Since the job ran on Monday (not the weekend) modifier X does not apply. It ran at 1200 (the middle of SHIFT2); therefore, modifier Z does not apply). Only modifier Y applies resulting in a discount of 10%.

**Record 3** meets only modifier Z's rules: it ran in SHIFT3. Therefore, a 20% discount is applied.

**Record 4** meets **both** modifier Y's and Z's rules: the structure is EAST and it ran during SHIFT3. Therefore, this record gets a 10% discount from modifier Y and a 20% discount from modifier Z. At invoice time, this record's calculated charges will show a net discount of 30%.

Now let's take another look at Example 1, changing its Exit on True to No. We apply the following rules:

	Processing Order	Example 1 Modifier X	Example 2 Modifier Y	Example 3 Modifier Z
1.	ORD	MBJ	ALL	ALL

	<b>Processing Order</b>	<b>Example 1 Modifier X</b>	<b>Example 2 Modifier Y</b>	<b>Example 3 Modifier Z</b>
2.	Element Criteria	CPU-CHARGE		
3.	Qualifier Criteria			
4.	Structure		EAST	
5.	Sequence	100	200	300
6.	Qualifier	@WEEKEND		@SHIFT3
7.	Exit on True	N	N	Y
8.	Modify Amount	+10%	-10%	-20%

**Note:** If Example 1 Exit on True is No, then the following rules are applied:

<b>Record</b>	<b>ORD</b>	<b>Charge Element</b>	<b>Field1</b>	<b>Field2</b>	<b>Struct</b>
1	MBJ	CPU-CHARGE	Saturday	2359	EAST

Because Exit on True=N for modifier X, modifiers Y and Z are now tested. Because this record also meets the rules for Modifier Y and Z, two additional modified records are generated. This gives us a total of three modified records whose results are stored on the CCCTAB: (1) with a surcharge of +10%, (2) with a discount of 10%, and (3) with a discount of 20%. At invoice time, this record's calculated charges show a net discount of 20%.

The examples on the following pages show you how to enter the modifier rules on Modifier Entry panels.

### Example 1: Modifying Charges Using ORD & Element Criteria

The panel below shows how to modify MBJ CPU-CHARGE charge element records for work performed on weekends. The selection criteria is ORD Type: MBJ and Element criteria: CPU-CHARGE.

In this example, we are adding a 10 percent surcharge for all MBJ CPU-CHARGES meeting the test @WEEKEND (Saturday or Sunday). We will Exit on True. The surcharge is applied **without** regard to accounting level. The algorithm for modifiers is:

```

          Modifier
Charge   WEEKEND
Element  -----
CPU-CHARGE * |+.10 | = Modified CPU-CHARGE
          -----
    
```

```

USERID          CA PMA Chargeback          MM/DD/YY HH:MM:SS
--            Acctdefs Cbdefs Query Data Period Options Exit Help
+-- CBCMODE ----- Modifier Entry -----+
|
| Panel Exit Help
|-----|
| Version . . . : PROD      Modifier : X
| ORD Type . . . : MBJ
|
| Element criteria . . CPU-CHARGE_____
| Qualifier criteria . _____
| Modify Amount . . . . +10.00000 or % P Exit on true Y
| Qualifier . . . . . @WEEKEND_____
| Sequence number . . 00100
| DIVISION . . . . . _____
| DEPARTMENT . . . . . _____
| SECTION . . . . . _____
| GROUP-ID . . . . . _____
| TEAM . . . . . _____
|
| F5=Save F6=Delete
|-----|
+-----+

Command ==>
F1=Help F3=Exit F4=Prompt F9=Command F10=Action Bar F12=Cancel PA1=Susp
    
```

## Example 2: Modifying Charges by Structure

In this example, we are giving all users in the EAST accounting entity a 10 percent discount on all resources used. This discount is applied **without** regard to the ORD, Element, or Qualifier.

```

USERID          CA PMA Chargeback          MM/DD/YY HH:MM:SS
--- Acctdefs Cbdefs Query Data Period Options Exit Help
+-- CBCMODE ----- Modifier Entry -----+
| Panel Exit Help |
|-----|
| Version . . . : PROD      Modifier : Y |
| ORD Type . . . : ALL      |
|-----|
| Element criteria . . _____ |
| Qualifier criteria . . _____ |
| Modify Amount . . . _____ -10.00000 or % P Exit on true N |
| Qualifier . . . . . _____ |
| Sequence number . . 00200 _____ |
| DIVISION . . . . . EAST _____ |
| DEPARTMENT . . . . . _____ |
| SECTION. . . . . _____ |
| GROUP-ID . . . . . _____ |
| TEAM . . . . . _____ |
|-----|
| F5=Save F6=Delete |
+-----+

Command ==> _____
F1=Help F3=Exit F4=Prompt F9=Command F10=Action Bar F12=Cancel PA1=Susp

```

**Note:** Modifiers greatly reduce the number of qualifiers and qualified rates required.

### Example 3: Modifying Charges by Qualifier

In this example, all records meeting modifier Z's @SHIFT3 qualifier test has their calculated units and costs reduced by 20 percent.

```

USERID          CA PMA Chargeback          MM/DD/YY HH:MM:SS
--  Acctdefs  Cbdefs  Query  Data  Period  Options  Exit  Help
+-- CBCMODE ----- Modifier Entry -----+
|   Panel  Exit  Help
|-----+
| Version . . . : PROD      Modifier : Z
| ORD Type . . . : ALL
|
| Element criteria . . _____
| Qualifier criteria . _____
| Modify Amount . . . -20.00000 or % P Exit on true Y
| Qualifier . . . . . @SHIFT3_____
| Sequence number . . 00300
| Division . . . . . _____
| Department . . . . . _____
| Section . . . . . _____
| Group-id . . . . . _____
| Team . . . . . _____
|
| F5=Save  F6=Delete
+-----+

Command ==> _____
F1=Help  F3=Exit  F4=Prompt  F9=Command  F10=Action Bar  F12=Cancel  PA1=Susp
    
```

## Example 4: Using a Wildcard with Selection Criteria

In this example, we are selecting all records that meet the @SHIFT% criteria for modifier testing, those records that also meet the @CPUIDA test have their calculated units and charges reduced by 50 percent.

```

USERID                                CA PMA Chargeback                                MM/DD/YY HH:MM:SS
---  Acctdefs  Cbdefs  Query  Data  Period  Options  Exit  Help
+-- CBCMODE ----- Modifier Entry -----+
|   Panel  Exit  Help
|-----+
| Version . . . : PROD      Modifier : SPECIAL
| ORD Type . . . : ALL
|
| Element criteria . . _____
| Qualifier criteria . @SHIFT%_____
| Modify Amount . . . -50.00000 or % P Exit on true Y
| Qualifier . . . . . @CPUIDA_____
| Sequence number . . 02000
| DIVISION . . . . . _____
| DEPARTMENT . . . . . _____
| SECTION . . . . . _____
| GROUP-ID . . . . . _____
| TEAM . . . . . _____
|
| F5=Save  F6=Delete
+-----+
Command ==>
F1=Help  F3=Exit  F4=Prompt  F9=Command  F10=Action Bar  F12=Cancel  PA1=Susp

```

## Defining Split Resources

CA PMA Chargeback enables you to split charges calculated for a specific accounting level across its entities. The charge distribution capability is useful because:

- The cost of a job can be split among the specific entities responsible for its use
- The total cost for an accounting level can be summarized and an invoice produced
- Resource statistics are retained even if its cost is split

Split processing occurs **after** charges are calculated for a given Consolidated Calculated Charge (CCC). If the record is associated with a split, then the charge is prorated and new records are created.

The Split definition is very similar to the Modifier definition, in that:

- Processing takes place at Detail function time (after the charges are calculated for a given CCC detail record)
- Additional CCC detail records are created

If the record is associated with a Split, then the CCC detail record is prorated and new CCC detail records are created and passed to the Summarization process for writing to the CCCTAB table.

The following panels make up the Split Charges panel set:

- Split Charges primary panel
- Split Charges List panel
- Expanded Split Charges List panel
- Split Charges Entry panel

**Note:** Protected display field areas are preceded by a colon (:).

## Split Charges Primary Panel

The Split Charges primary panel is used for creating, examining or modifying a Split Charge. A Split Charge name can be up to 16 alphanumeric characters.

The following panel shows a request to browse or create a Split Charge named PAYROLL for ORD Type MBJ.

```

USERID                               CA PMA Chargeback                MM/DD/YY HH:MM:SS
---  Acctdefs  Cbdefs  Query  Data  Period  Options  Exit  Help
+-- CBCSPLP ----- Split Charges -----+
|                                     |
|                                     |
| Type information. Then select an action. |
|                                     |
| Version . . . : PROD                |
| ORD Type . . . : MBJ                 |
| Split Charge . : PAYROLL             |
|                                     |
| F2=Create  F11=Browse                |
+-----+

```

This panel associates an ORD type, as defined by the CA PMA Chargeback Administrator, with a split charge.

Command ==> \_\_\_\_\_  
F1=Help F3=Exit F4=Prompt F9=Command F10=Action Bar F12=Cancel PA1=Susp

Remember, you can enter the SQL wildcard character % at either or both prompts to display a full browse list of all currently defined ORDs and/or Split Charges.

Next is a description of the Split Charges primary panel.

### Access

The Split Charges primary panel appears when one of these events occurs:

- You type CS in the fast path area of the CA PMA Chargeback Primary Panel's action bar.
- You select Cbdefs from the CA PMA Chargeback Primary Panel's action bar and then choose Split Job Charges.
- You return to this panel from the Split Charges List, Expanded List, or Entry panel using **F3**.

```

-----
|Cbdefs Pull-down|_____
|>Split Job      |         |
|  Charges       |         v
-----

```

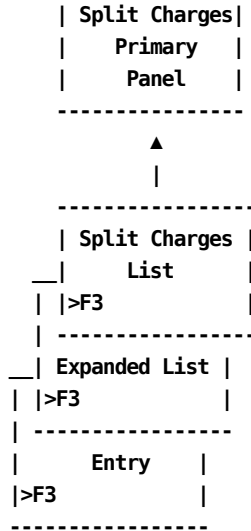

**Input**

The Split Charges primary panel contains the following entry field:

**ORD Type**

A three-character name of the output record identifier you want to define, view or modify.

When using F11 (Browse): if you do not know the ORD Type name, enter the SQL wildcard character %. This gives you a list of all ORD Types meeting the Split Charge you specify in the next field. Or you can enter a % at both the ORD Type and Split Charge prompts to get a list of all defined ORDs and Split Charges.

**Split Charge**

The name (up to 16 alphanumeric characters) of the Split Charge you want to create, view, or modify.

**Pathways**

**F2**

**(Create)** Takes you to the Split Charges Entry panel (section Split Charges Entry Panel).

**F11**

**(Browse)** Takes you to the Split Charges List panel (section Split Charges List Panel).



```
| Expand. List | _____ |
|>F3          |
-----
```

**Scrolling**

F7 and F8 let you scroll backward and forward through the Split Charge selection list. You can also use the scroll bar to move through the list.

**Pathways**

**Enter**

Place the cursor next to the selected item and press Enter.

**F11**

**(Expand)** Provides you with an **expanded** (eight-line display) view of the Split Charges List panel.

## Split Charges Expanded List Panel

The following panel appears when you press F11 (Expand) on the Split Charges List panel shown in Split Charges List Panel. The only difference between the two panels is the Version, ORD Type, and Split Charge protected fields are not displayed. This allows you to view more information on a single panel. The Expanded List panel functions in the same way as the panel from which it was called.

```

USERID                               CA PMA Chargeback                MM/DD/YY HH:MM:SS
--  Acctdefs Cbdefs  Query  Data  Period  Options  Exit  Help
+-- CBCSPLX ----- Expanded Split Charges List -----+
   Panel Exit Help
   -----
   Select Split Charge name. Then Enter.
   More: - + ____ Row 0001 of 0001
   ORD Split Charge
   _ MBJ PAYROLL
   -
   -
   -
   -
   -
   -
   Enter  F7=Bkwd  F8=Fwd
+-----+

Command ==>
F1=Help  F3=Exit  F4=Prompt  F9=Command  F10=Action Bar  F12=Cancel  PA1=Susp

```

## Split Charges Entry Panel

The Split Charges Entry panel is used to define how you want to split the cost of resources among your accounting entities. When you create a split charge definition, the Original, New and Percent columns are blank. A split charge always requires at least 2 entry panels for definition as shown in Example 1 in Example 1: Splitting a Resource Charge Between Two Accounting Levels in example 2 in Example 2: Splitting a Resource Charge Among Four Accounting Levels.

The panel below shows how to create a Split Charge, named PAYROLL. After you enter original information, press F5 to save the data. Examples 1 and 2 show you how to continue the split charge definition.

```

USERID                               CA PMA Chargeback                MM/DD/YY HH:MM:SS
--  Acctdefs Cbdefs  Query Data  Period  Options  Exit  Help
+-- CBCSPLE ----- Split Charges Entry -----+
| Panel  Exit  Help                               |
|-----|
| Type Original information. Then select an action. |
| Version . . . : PROD                               |
| Ord Type . . . : MBJ                               |
| Split Charge : PAYROLL                            Percent Used: 0.00% |
|                                     Original        New          Percent |
| Division . . . : DEVELOPMENT                      |-----|
| Department . . : EAST COAST                       |-----|
| Section . . . . : ACCOUNTING                      |-----|
| Group-id . . . . : QA                             |-----|
| Team . . . . . : CHARGEBACK                       |-----|
| F5=Save  F6=Delete  F7=Prev  F8=Next  F11=Insert |
+-----+
Command ==>
F1=Help  F3=Exit  F4=Prompt  F9=Command  F10=Action Bar  F12=Cancel  PA1=Susp
    
```

Next is a description of the Split Charges Entry panel.

### Access

The Split Charges Entry panel appears when one of these events occurs:

- When you press **F2** (Create) on the Split Charges primary panel shown in Split Charges Primary Panel.
- You make a selection on the Split Charges List or Expanded List panel.

```

-----
| Split Charges |
| Expanded List |
|>Enter       |
-----
    
```

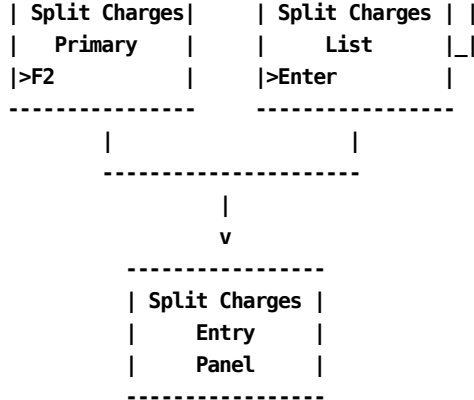

**Input**

The Split Charges entry panel contains the following entry fields:

**Percent Used**

Upon initial entry to this panel, the value displayed is 0. After the first *new* structure is defined, the defined percentage is reflected in this field. Note that the panel instruction line changes from original to new. Continue entering new information until Percent Used equals 100%.

**Note:** Percent Used **must** equal 100.00% Any attempt to save this panel when Percent Used does not equal 100% will fail.

The following entry fields are used to indicate the accounting levels you want the debits and credits applied to:

**Note:** Only defined accounting levels are displayed.

**Original**

Lists the original accounting entities to which the resource is attributed.

**New**

Use this column to list the names of the accounting entities you want the charges split to.

**Note:** You also have the option of typing the word **PRESERVE** in this column. PRESERVE allows you to retain the original entity without having to retype the entity name.

**Percent**

The percentage amount of the charge you want attributed to the *new* entity.

**Actions**

**F5=Save**

Lets you save the information on the panel.

**F6=Delete**

Deletes the Split Charge definition. This key is only valid after an entry has been entered completely.

**F7=Previous**

Takes you to any previous Split Charge Entry panels used to define the split. (Active in update mode only.)

**F8=Next**

Takes you to the next panel where you can continue to define or view the split charge. You can use as many panels as necessary to define the split. However, the combined percentages of the split must equal 100%. (Active in update mode only.)

**F11=Insert**

Only valid when you are in update mode and percent does not equal 100%.

**Note:** Update mode is active only after first defining a split charge completely (Percent Used=100.00). Once defined, split charges may be updated by overtyping the percent fields. F5 to save updated data may cause Percent Used to be less than 100%. By pressing the F11 key, the New information area will be cleared, allowing you to 'insert' new split information (to set Percent Used back to 100%).

### Example 1: Splitting a Resource Charge Between Two Accounting Levels

In the following example, the first panel shows the original split charge definition we created and saved in Split Charges Entry Panel. We now define a split charge (PAYROLL) that attributes 60% of the charge to the Princeton Department and 40% to the Reston Department. We do this by:

- Modifying the New column as shown below (note the use of the PRESERVE option)
- Modify the Percent column to reflect that 60% goes to Princeton.
- Saving the entry by pressing F5 (Save)

**Note:** If you are in **input** mode, after you press F5 the New column automatically blanks out so that new data can be entered. F8 (Next) is only active in **update** mode.

Next, we modify the New column on the second panel to reflect that 40% of the charge should be against the Reston Department.

```
+-- CBCSPLE ----- Split Charges Entry -----
|
|   Panel   Exit   Help
|
| -----
|
| Type Original information. Then select an action.
|
|
| Version . . . : PROD
| Ord Type . . : MBJ
| Split Charge : PAYROLL          Percent Used  60.00%
|
|           Original      New          Percent
| Division . . . . DEVELOPMENT  PRESERVE      60.00%
| Department . . . . EAST COAST  PRINCETON
| Section . . . . . ACCOUNTING   PRESERVE
| Group-id . . . . . QA          PRESERVE
| Team . . . . . . . CHARGEBACK  PRESERVE
|
|
|   F5=Save   F6=Delete   F7=Prev   F8=Next   F11=Insert
```

## Example 2: Splitting a Resource Charge Among Four Accounting Levels

In the following example, the first panel shows the original split charge definition we created and saved in Split Charges Entry Panel. We will now define a split charge (PAYROLL) that attributes 25% of the charge to the Princeton Department, 25% to the Reston Department, 25% to the Garden City Department, and 25% to the Maitland Department. We do this by:

- Modifying the New column and the Percent column as shown below
- Saving the entry by pressing F5 (Save). See note on previous page.

We then modify the New column on the second panel to reflect that 25% of the charge should be against the Princeton Department. We continue in this manner until we have completed the split among all entities and the Percentage Used equals 100%.

```

+-- CBCSPLE ----- Split Charges Entry -----+
|      Panel  Exit  Help                          |
| -----|
| Type Original information. Then select an action. |
|                                                    |
| Version . . . : PROD                              |
| Ord Type . . : MBJ                                |
| Split Charge : PAYROLL          Percent Used: 25.00% |
|                                                    |
|              Original          New          Percent |
| Division . . . . DEVELOPMENT    DEVELOPMENT    25.00% |
| Department . . . . EAST COAST    PRINCETON      |
| Section . . . . . ACCOUNTING    ACCOUNTING    |
| Group-id . . . . . QA            QA            |
| Team . . . . . . . CHARGEBACK    CHARGEBACK    |
|                                                    |
| F5=Save  F6=Delete  F7=Prev  F8=Next  F11=Insert |
+-----+

```

```
+-- CBCSPLE ----- Split Charges Entry -----+
|      Panel  Exit  Help                          |
| -----|
| Type new information and save. Or select an action. |
|                                                    |
| Version . . . : PROD                              |
| Ord Type . . : MBJ                                |
| Split Charge : PAYROLL          Percent Used: 75.00% |
|                                                    |
|              Original          New          Percent |
|                                                    |
| Division . . . . DEVELOPMENT    DEVELOPMENT    25.00% |
| Department . . . EAST COAST     GARDEN CITY    |
| Section . . . . ACCOUNTING      ACCOUNTING    |
| Group-id . . . . QA             QA             |
| Team . . . . . CHARGEBACK       CHARGEBACK    |
|                                                    |
| F5=Save  F6=Delete  F7=Prev  F8=Next  F11=Insert |
+-----+-----+

```

## Shift Chop Definition

To allow equitable allocation and calculation of charges to ORD records that *span* shifts, we implement a shift chop definition. The reason for using Shift Chop definitions is illustrated by the following example. Suppose no Shift Chops were defined and a five hour job started one minute before the end of the first shift. The entire five hours would be charged at the first shift's rate, even though 99% of the job executed during the second shift. As you can see, using Shift Chop definitions ensure equitable allocation and calculation of charges.

This function is activated at the Detail function time, and is similar to split processing, since it creates multiple records from a single input. However, unlike split processing, the interval chop routines are performed **before** creation of the CCC detail record, at ORD reception time. It is as if multiple ORD records were presented to the detail function routines. Up to four **chop times** can be specified. In the example below, we have specified three.

```

USERID          CA PMA Chargeback          MM/DD/YY HH:MM:SS
  Acctdefs      Cbdefs  Query  Data  Period  Options  Exit  Help
  +- CBCCHPE ---- Shift Chop -----+
  | Panel Exit Help                    |
  |-----|
  | Type information. Then select an action. |
  |
  | Version : PROD                       |
  |
  | Start                                  |
  | HH:MM                                 |
  |
  | First shift . 08:00                   |
  | Second shift . 16:00                   |
  | Third shift . 24:00                   |
  | Fourth shift . _____              |
  |
  | F5=Save  F6=Delete                    |
  |-----|
  +-----+

Command ==> _____
F1=Help  F3=Exit  F4=Prompt  F9=Command  F10=Action Bar  F12=Cancel  PA1=Susp

```

The following is a description of the Shift Chop Entry panel.

### Access

The Shift Chop entry panel appears when one of these events occurs:

- You type CB in the fast path area of the CA PMA Chargeback Primary Panel's action bar.
- You select Shift Chop on the Cbdefs pull-down.

-----

Cbdefs	_____
Pull-down	
>Shift Chop	v
-----	
	Shift Chop
	Entry
	Panel
	-----

### Input

The Shift Chop panel contains the following input field:

#### Start HH:MM

This field is used to specify the time at which you want a shift interval chopped or *started* (format is HH MM).

### Actions

#### F5=Save

Lets you save your entries.

#### F6=Delete

Deletes all entries.

## Example: Defining a Shift Chop

Up to four *Chop* times can be specified. We have specified three on the sample panel below:

- 8 AM (08 00)
- 4 PM (16 00)
- midnight (24 00)

USERID	CA	PMA	Chargeback	MM/DD/YY	HH:MM:SS
Acctdefs	Cbdefs	Query	Data	Period	Options
Exit	Help				
+-- CBCCHPE ---- Shift Chop -----+					
Panel Exit Help					
-----					
Type information and save. Or delete.					
-----					
Version : PROD					
Start					
HH:MM					
First shift . 08:00					
Second shift . 16:00					
Third shift . 24:00					
Fourth shift . _____					
-----					
F5=Save F6=Delete					
-----					
Command ==> _____					
F1=Help F3=Exit F4=Prompt F9=Command F10=Action Bar F12=Cancel					

For example, if an ORD record has a Start Time of 07:00 and a Stop Time of 17:00, it spans multiple intervals. Interval records would be created for the following:

- 07:00 -> 07:59 Start Time to next Interval Boundary
- 08:00 -> 15:59 Interval Boundary to next Interval Boundary
- 16:00 -> 17:00 Interval Boundary to Stop Time

This splitting should, in most cases, match the user-defined Shift qualifiers.

**Note:** If shift qualifiers have been defined, there is no checking against Shift Chop to ensure that the defined shift times are the same.



# Chapter 5: Defining Adjustments

---

## Overview

The Cbdefs options discussed in this chapter, like those in Chapter 4, are executed when you select **Cbdefs** from the CA PMA Chargeback Primary Panel's action bar by placing the cursor next to the Cbdefs keyword and pressing Enter. You see the same Cbdefs Pull-down.

While all of the choices are available to you, the following choices are **not** discussed in this chapter: Choices 1 through 7 are used in rate definition and are discussed in Chapter 8.

With CA PMA Chargeback you can perform adjustments such as Cost Recovery and Overhead Distribution when charging for resources, using the following Cbdefs options which are discussed in this chapter:

**8**

Cost Recovery (T)

**9**

Overhead Distribution

The following panel provides a table of the choices available to you when defining adjustments.

**Cbdefs Pull-Down**

USERID	CA PMA Chargeback	MM/DD/YY HH:MM:SS
__ Acctdefs Cbdefs Query Data Period Options Exit Help		
<div style="border: 1px dashed black; padding: 5px;"> <p style="text-align: center;">CB Definitions</p> <p>1. Charge Elements</p> <p>2. Charge Units (U)</p> <p>3. Qualifiers</p> <p>4. Normalizer</p> <p>5. Modifiers</p> <p>6. Split Job Charges</p> <p>7. Shift Chop (B)</p> <p>8. Cost Recovery (T)</p> <p>9. Overhead Distribution</p> <hr style="border-top: 1px dashed black;"/> <p>F12=Cancel</p> </div>		<p>A 1-character field that allows you to make a selection using a mnemonic that can be either a number or the first letter of an action. Notice that when actions have duplicate first letters, you can use either the number or the letter provided in the parentheses.</p> <p>You can also make your selection by tabbing the cursor next to the action you want to perform and pressing Enter.</p>
<p>Command ==&gt; _____</p> <p>F1=Help F3=Exit F4=Prompt F9=Command F10=Action Bar F12=Cancel PA1=Susp</p>		

The following choices are discussed in this chapter:

**8. Cost Recovery**

Gives you the ability to recover costs for a specific resource and specify the recovery amount.

**9. Overhead Distribution**

Lets you distribute charges for a shared resource.

Both Cost Recovery and Overhead Distribution are performed **after** record summarization has occurred for the period in which you want these adjustments applied.

Adjustments operate on the **actual** charges found in CCCTAB not the units. This means that the charge may be the result of either a minimum or maximum charge being applied to a element rather than the charge being the product of charge units multiplied by the rate. Therefore, when an adjustment is applied, a new record is created in CCCTAB which may have values for the units and rate that when multiplied together do **not equal** the charge, but, the charge divided by the rate equals the units.

## Cost Recovery Panels

Cost Recovery enables you to:

- Recover costs for a specific resource
- Specify the amount you want to recover
- Provide allocation targets based on user-defined criteria
- Prorate the recovery amount based on current charges contained in CA PMA Chargeback records
- Create cost recovery charge records to maintain auditability (summary modifiers)

The following panels make up the Cost Recovery panel set:

- Cost Recovery primary panel
- Cost Recovery List panel
- Expanded Cost Recovery List panel
- Cost Recovery Entry panel

## Cost Recovery Primary Panel

Cost recovery enables you to recover a specific amount for a resource from the entities using the resource. The Cost Recovery primary panel is used for creating, examining or modifying a Cost Recovery definition. A cost recovery name can be up to 16 alphanumeric characters. The following panel shows how to request a list of Cost Recovery definitions for MBJ ORD types.

```

USERID          CA PMA Chargeback          MM/DD/YY HH:MM:SS
----- Acctdefs Cbdefs Query Data Period Options Exit Help
+---+ CBCRECP ----- Cost Recovery -----+
|                                     |
|   Panel   Exit   Help              |
|-----|
|   Type information. Then select an action.
|
|   Version . : PROD
|   ORD Type . . MBJ
|   Recovery . . %
|
|   F2=Create   F11=Browse
|-----+
+---+

This panel optionally associates an ORD record type, as defined
by the CA PMA Chargeback Administrator, with a Recovery name.

Command ==> _____
F1=Help  F3=Exit  F4=Prompt  F9=Command  F10=Action Bar  F12=Cancel  PA1=Susp
    
```

The following is a description of the Cost Recovery primary panel.

### Access

The Cost Recovery primary panel appears when one of these events occurs:

- You type CT in the fast path area of the CA PMA Chargeback Primary Panel's action bar.
- You choose Cost Recovery on the Cbdefs pull-down.
- You return from the Cost Recovery List or Entry panel.

```

-----
|   Cbdefs   | _____
|Pull-down Menu|         |
|>Cost Recovery|         v
-----
| Cost Recovery|
|   Primary   |
|   Panel     |
-----
    
```

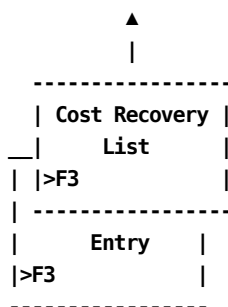

### Input

The Cost Recovery primary panel contains the following input fields:

#### ORD Type

The three-character name of the output record identifier for which you want to define, view or modify a Recovery amount.

#### Recovery

The name (up to 16 alphanumeric characters) of the recovery you want to define, view, or modify.

### Pathways

#### F2

**(Create)** Takes you to the Cost Recovery Entry panel (section Cost Recovery Entry Panel).

#### F11

**(Browse)** Takes you to the Cost Recovery List panel (section Cost Recovery List Panel).

## Cost Recovery List Panel

The Cost Recovery List panel displays a list of all currently defined cost recovery definitions meeting the criteria specified on the Cost Recovery primary panel. The search criteria are redisplayed as protected display fields. The following panel shows all Recovery definitions currently defined for Version PROD.

```

USERID          CA PMA Chargeback          MM/DD/YY HH:MM:SS
  Acctdefs      Cbdefs      Query  Data  Period  Options  Exit  Help
+---+-----+-----+-----+-----+-----+-----+-----+
| CBCRECL |-----| Cost Recovery List |-----|
| Panel   | Exit  Help |
|-----|-----|-----|-----|
| Select a recovery name. Then Enter.
|
| Version . : PROD
| ORD Type . : MBJ
| Recovery . : CPU-ADJUSTMENT
|
| ORD Recovery Name
|
| MBJ CPU-ADJUSTMENT
| MBJ DISKIO-MOUNTS
|
| More: - + ____ Row 0001 of 0002
|
| Enter  F7=Bkwd  F8=Fwd  F11=Expand
+-----+-----+-----+-----+
Command ==>
F1=Help  F3=Exit  F4=Prompt  F9=Command  F10=Action Bar  F12=Cancel  PA1=Susp
    
```

### Access

The Cost Recovery List panel appears when one of these events occurs:

- You press **F11** (Browse) on the Cost Recovery primary panel shown in Cost Recovery Primary Panel.
- You return from the Expanded Cost Recovery List panel using F3.

```

-----
| Cost Recovery|_____
|   Primary   |         |
|>F11        |         v
-----
| Cost Recovery |
|   List       |
|   Panel     |
-----
-----
| Expanded    |         |
| Cost Rec List|_____
|>F3        |
    
```

-----  
**Scrolling**

F7 and F8 let you scroll backward and forward through the Recovery Name selection list. You can also use the scroll bar, as explained on page Sample List Panel, to move through the list.

**Pathways**

**Enter**

By placing the cursor next to the required item and pressing **Enter**, you can go to the Cost Recovery Entry panel (shown in Cost Recovery Entry Panel) to examine and optionally update the item.

**F11**

**(Expand)** Provides you with an **expanded** (eight-line display) view of the Cost Recovery List panel.

## Expanded Cost Recovery List Panel

The following panel appears when you press F11 (Expand) on the Cost Recovery List panel. The only difference between the two panels is the Version, ORD Type and Recovery protected fields are not displayed. This allows you to view more information on a single panel. The Expanded List panel functions in the same way as the panel from which it was called.

```

USERID                               CA PMA Chargeback                MM/DD/YY HH:MM:SS
--  Acctdefs  Cbdefs  Query  Data  Period  Options  Exit  Help
+--  CBCRECX  -----  Expanded Cost Recovery List -----+
      Panel  Exit  Help
-----+-----
      Select a Recovery name. Then Enter.

      ORD  Recovery Name                More: - + ____  Row 0001 of 0002

      MBJ  CPU-ADJUSTMENT
      MBJ  DISKIO-MOUNTS

      Enter  F7=Bkwd  F8=Fwd
-----+-----

Command ==>
F1=Help  F3=Exit  F4=Prompt  F9=Command  F10=Action Bar  F12=Cancel  PA1=Susp
    
```





Deletes the Cost Recovery entry.

### Example 1: Cost Recovery From a Single Accounting Level

The panel below shows how to create a Cost Recovery definition called CPU-ADJUSTMENT for MBJ ORD types:

- With a recovery amount of \$100
- For the third billing period
- For all departments in the East Coast Division

```

USERID          CA PMA Chargeback          MM/DD/YY HH:MM:SS
--  Acctdefs  Cbdefs  Query  Data  Period  Options  Exit  Help
+--  CBCRECE  -----  Cost Recovery Entry -----+
|
|   Panel  Exit  Help
|-----+
|   Type information. Then select an action.
|
|   Version . . . : PROD          ORD Type : MBJ
|   Recovery . . . : CPU-ADJUSTMENT
|
|   Charge Element . CPU-CHARGE_____ Recovery Amt .      100.00000
|   Qualifier . . . _____
|   Period Number . 003
|   Division . . . . EAST COAST_____
|   Department . . . _____
|
|
|   F5=Save  F6=Delete
+-----+

Command ==> _____
F1=Help  F3=Exit  F4=Prompt  F9=Command  F10=Action Bar  F12=Cancel  PA1=Susp
    
```

## Example 2: Cost Recovery from All Accounting Levels using a Qualifier

The panel below shows how to create a Cost Recovery definition called CPU-ADJUSTMENT for MBI ORD types:

- For the fifth billing period
- With a recovery amount of 5000
- From all @SHIFT1 definitions
- For all Divisions and Departments

```

USERID          CA PMA Chargeback          MM/DD/YY HH:MM:SS
--- Acctdefs  Cbdefs  Query  Data  Period  Options  Exit  Help
+-- CCRECE ----- Cost Recovery Entry -----+
|   Panel  Exit  Help
|-----+
| Type information. Then select an action.
|
| Version . . . : PROD          ORD Type : MBI
| Recovery . . . : CPU-ADJUSTMENT
|
| Charge Element . CPU-CHARGE_____ Recovery Amt .      5000.00000
| Qualifier . . . @SHIFT1_____
| Period Number . 005
| Division . . . . _____
| Department . . . _____
|
|
| F5=Save  F6=Delete
+-----+
Command ==> _____
F1=Help  F3=Exit  F4=Prompt  F9=Command  F10=Action Bar  F12=Cancel  PA1=Susp
    
```

## Performing Overhead Distribution

Overhead distribution gives you the ability to:

- Distribute charges for a shared resource
- Retrieve an overhead amount from existing CA PMA Chargeback database records
- Distribute overhead charges in relation to the current charges in the targeted summary record
- Debit the original CA PMA Chargeback records accordingly
- Select distribution targets based on user-defined criteria

while maintaining auditability based on the creation of Overhead Charge records.

The Overhead Distribution algorithm used to accomplish the above objectives is:

$$\text{Overhead Charge} = \text{Overhead Amount} / \text{Sum of Charges} * \text{Current Charge}$$

The following panels make up the Overhead Distribution panel set:

- Overhead Distribution primary panel
- Overhead Distribution List panel
- Expanded Overhead Distribution List panel
- Overhead Distribution Entry panel

## Overhead Distribution Primary Panel

The Overhead Distribution primary panel is used for creating, modifying, or examining an Overhead Distribution definition.

The following panel shows you how to request a list of all Overhead entries for MBJ ORD types.

```

USERID          CA PMA Chargeback          MM/DD/YY HH:MM:SS
----- Acctdefs Cbdefs Query Data Period Options Exit Help
+--- CBCOVHP ----- Overhead Distribution -----+
|
| Panel Exit Help
|-----+
|
| Type information. Then select an action.
|
| Version . . : PROD
| Target ORD . MBJ
| Overhead . . %
|
| F2=Create F11=Browse
+-----+

This panel associates an ORD record type, as defined by
the CA PMA Chargeback Administrator, with an Overhead name.

Command ==> _____
F1=Help F3=Exit F4=Prompt F9=Command F10=Action Bar F12=Cancel PA1=Susp
    
```

Next is a description of the Overhead Distribution primary panel.

### Access

The Overhead Distribution primary panel appears when one of these events occurs:

- You type CO in the fast path area of the Primary Panel's action bar.
- You choose Overhead Distribution on the Cbdefs pull-down.
- You return from the Overhead Distribution List or Entry panel.

```

-----
| Cbdefs | _____
| Pull-down Menu | |
| >Overhead | |
| Distribution | v
|-----+-----+
| Overhead |
| Distribution |
| Primary |
| Panel |
|-----+-----+
    
```

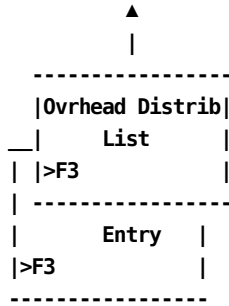

**Input**

The Overhead Distribution primary panel contains the following input fields:

**Target ORD**

The three-character name of the output record identifier for which you want to define, view or modify an Overhead Distribution definition.

When using F11=Browse: if you do not know the ORD Type name, you can enter the SQL wildcard character %. This provides you with a list of all ORD Types meeting the Overhead name you specify in the next field, or you can enter a % in both the ORD Type and Overhead prompts to get a list of all defined ORDs and Overhead names.

**Overhead**

The name (up to 16 alphanumeric characters) of the Overhead you want to define, view, or modify.

**Pathways**

**F2**

**(Create)** Takes you to the Overhead Distribution Entry panel (section Overhead Distribution Entry Panel).

**F11**

**(Browse)** Takes you to the Overhead Distribution List panel (section Overhead Distribution List Panel).

## Overhead Distribution List Panel

The Overhead Distribution List panel displays a list of all currently defined Overhead names meeting the criteria specified on the Overhead Distribution primary panel. The search criteria are redisplayed as protected fields. The following panel shows a list of Overhead Distribution definitions currently defined for ORD type MBJ.

```

USERID          CA PMA Chargeback          MM/DD/YY HH:MM:SS
--- Acctdefs   Cbdefs   Query  Data  Period  Options  Exit  Help
+-- CBCOVHL ----- Overhead Distribution List -----+
|   Panel      Exit  Help
|
| Select an overhead name. Then Enter.
|
| Version . : PROD
| Target ORD : MBJ
| Overhead . : %
|
|                                     More: - + ____ Row 0001 of 0004
|
|   ORD Overhead
|
|   MBJ OPERATING-OVRH
|   MBJ PERSONNEL-OVRH
|   MBJ DATA-CTR-OVRH
|   MBJ JES-OVERHEAD
|
| Enter  F7=Bkwd  F8=Fwd  F11=Expand
+-----+
Command ==>
F1=Help  F3=Exit  F4=Prompt  F9=Command  F10=Action Bar  F12=Cancel  PA1=Susp
    
```

A description of the Overhead Distribution List panel follows.

### Access

The Overhead Distribution List panel appears when one of these events occurs:

- You press **F11** (Browse) on the Overhead Distribution Primary panel shown in Overhead Distribution Primary Panel.
- You return from the Expanded Overhead Distribution List panel using F3.

```

-----
|  Overhead  | _____
| Distribution |
| Primary    |
|>F11       |      v
-----
| Ovrhd Distri |
| List         |
| Panel       |
-----
                    ▲
    
```

```
|   Expanded   |   |  
| Ovrhd Distrib|_____|  
|       List   |   |  
|>F3          |   |  
-----
```

### Scrolling

F7 and F8 let you scroll backward and forward through the Overhead selection list. You can also use the scroll bar to move through the list.

### Pathways

#### Enter

By placing the cursor next to the required item and pressing **Enter**, you can go to the Overhead Distribution Entry panel (section Modifier Entry Panel) to examine and optionally update the item.

#### F11

**(Expand)** Provides you with an **expanded** (eight-line display) view of the Overhead Distribution List panel.

## Expanded Overhead Distribution List Panel

The following panel appears when you press F11 (Expand) on the Overhead Distribution List panel. The only difference between the two panels is the ORD Type, and Overhead protected fields are not displayed. This allows you to view more information on a single panel. The Expanded List panel functions in the same way as the panel from which it was called.

```

USERID                                CA PMA Chargeback                                MM/DD/YY HH:MM:SS
---  Acctdefs  Cbdefs  Query  Data  Period  Options  Exit  Help
+--  CBCOVHX  ----- Expanded Overhead Distribution List -----+
      Panel    Exit    Help
      -----
      Select an overhead name. Then Enter.
      -----
      ORD  Overhead                                More: - + ____ Row 0001 of 0004
      MBJ  OPERATING-OVRH
      MBJ  PERSONNEL-OVRH
      MBJ  DATA-CTR-OVRH
      MBJ  JES-OVERHEAD
      -----
      Enter  F7=Bkwd  F8=Fwd
+-----+

Command ==> _____
F1=Help  F3=Exit  F4=Prompt  F9=Command  F10=Action Bar  F12=Cancel  PA1=Susp
    
```

## Overhead Distribution Entry Panel

The Overhead Distribution Entry panel is used to specify a definition for overhead recovery for a resource, for a specific period, as well as the accounting levels among which you want this overhead distributed.

The panel below shows how to create an Overhead Distribution definition called JES-OVERHEAD that is applied to MBJ ORD type records:

- For the CPU-CHARGE charge element
- With an Ovhd ORD Type of JES
- For the Ovhd Element: JES-OVHD-CHARGE
- For the third billing period
- Overhead distribution is across all Division and Department entities using the CPU-CHARGE resource

The following panel is actually the **rule** that governs the Overhead Distribution charge. The Ovhd ORD Type and Ovhd Element tell CA PMA Chargeback where (or who) the charge is coming from. The other entry fields tell CA PMA Chargeback where (or to which entities) the charge is to be distributed. Overhead Distribution prorates each level's charge(s). When overhead distribution is performed via CAKRSUM, new records are created: one record for each entity contributing to the original charge in a ratio that is proportional to its usage. The original record is retained with an adjusted charge of 0.

**Note:** Period Number is used as a criterion of the rule, but is not used in record selection.

```

USERID                               CA PMA Chargeback                               MM/DD/YY HH:MM:SS
--  Acctdefs  Cbdefs  Query  Data  Period  Options  Exit  Help
+-- CBCOVHE ----- Overhead Distribution Entry -----+
|   Panel  Exit  Help
|-----+
| Type information. Then select an action.
|
| Version . . . : PROD                               Target ORD : MBJ
| Overhead . . . : JES-OVERHEAD
|
| Charge Element . CPU-CHARGE_____ Ovhd ORD Type JES
| Qualifier . . . _____ Ovhd Element . JES-OVHD-CHARGE_
| Period Number . 003
| Division . . . _____
| Department . . . _____
|
| F5=Save  F6=Delete
+-----+
Command ==>
F1=Help  F3=Exit  F4=Prompt  F9=Command  F10=Action Bar  F12=Cancel  PA1=Susp
    
```



The period number for which the overhead should be calculated and distributed. (Not used in record selection) If the overhead is to be applied to all periods, specify 0 as the Period Number.

The following entry fields are used to indicate the accounting levels to which the overhead is distributed. This example uses the following accounting levels:

**Note:** When distributing overhead globally among the levels using the resource, these fields are left blank.

**Division**

Enter the name of a defined accounting level to which you want overhead charges distributed.

**Department**

Enter the name of a defined accounting level to which you want overhead charges distributed.

**Actions**

**F5=Save**

Lets you save the Overhead entry.

**F6=Delete**

Lets you delete the Overhead entry.

## Example 1: Distributing Overhead Globally Across Accounting Levels that Have a @SHIFT1 Qualification

The panel below shows how to create an Overhead Distribution definition called OVERHEAD for MBJ ORD types:

- For the CPU-CHARGE charge element
- To all @SHIFT1 records
- With an Ovhd ORD Type of XXX (This can be any ORD type your desire)
- With an Ovhd Charge Element name of DATA-CTR-OVRHD
- For the second billing period

```

USERID          CA PMA Chargeback          MM/DD/YY HH:MM:SS
---            Acctdefs Cbdefs  Query  Data  Period  Options  Exit  Help
+--- CBCOVHE ----- Overhead Distribution Entry -----+
|   Panel  Exit  Help                                     |
|-----|
| Type information. Then select an action.                |
| Version . . . : PROD                                Target ORD : MBJ  |
| Overhead . . . : OVERHEAD                            |
| Charge Element . CPU-CHARGE_____ Ovhd ORD Type  XXX  |
| Qualifier . . . @SHIFT1_____ Ovhd Element . DATA-CTR-OVRHD__ |
| Period Number . 002                                  |
| Division . . . _____                          |
| Department . . . _____                          |
|
| F5=Save  F6=Delete
+-----+
Command ==> _____
F1=Help  F3=Exit  F4=Prompt  F9=Command  F10=Action Bar
    
```

## Example 2: Distributing Overhead Among an Accounting Level

The panel below shows how to **modify** an Overhead Distribution definition called OVERHEAD for MBJ ORD types (created in Example 1 in Example 1: Distributing Overhead Globally Across Accounting Levels that Have a @SHIFT1 Qualification) so that overhead is distributed among all EAST COAST entities that used the resource during the second accounting period (002).

We will change the following input fields:

- Space over the Qualifier field input area so that @SHIFT1 is removed
- Type in EAST COAST at the Division prompt

```
USERID          CA PMA Chargeback          MM/DD/YY HH:MM:SS
-----  Acctdefs  Cbdefs  Query  Data  Period  Options  Exit  Help
+---+  CBCOVHE  -----  Overhead Distribution Entry  -----+
      Panel  Exit  Help
+-----+
| Type information. Then select an action.
|
| Version . . . : PROD          Target ORD : MBJ
| Overhead . . . : OVERHEAD
|
| Charge Element . CPU-CHARGE_____ Ovhd ORD Type  XXX
| Qualifier . . . _____ Ovhd Element . DATA-CTR-OVRHD__
| Period Number . 002
| Division . . . EAST COAST_____
| Department . . . _____
|
| F5=Save  F6=Delete
+-----+
Command ==> _____
F1=Help  F3=Exit  F4=Prompt  F9=Command  F10=Action Bar
```

# Chapter 6: Performing Query Functions

The CA PMA Chargeback Query option enables you to request information about the data in the:

- CCCTAB (Consolidated Calculated Charges Table)
- CCCMOD (Consolidated Calculated Charges Modified Table)
- BUDTAB (Budget Table)
- DBCRTAB (Debit and Credit Table)

CA PMA Chargeback, using the information you provide, generates the appropriate SQL (Structured Query Language) commands to retrieve the requested data. The Query functions allow you to save, update, and reexecute those queries you use most frequently.

The Query option discussed in this chapter is executed when you select **Query** from the CA PMA Chargeback Primary Panel's action bar. The Query pull-down, shown below, then appears. Make other selections by placing your cursor next to the function you want to perform and pressing the **Enter** key. You can also make selections by entering the mnemonic (either the first letter or the number) of the function in the fast path area of the Query pull-down.

USERID	CA PMA Chargeback	MM/DD/YY HH:MM:SS
— Acctdefs	Query Data Period Options	Exit Help
	Query	
	_ 1. Charge	
	2. Budget	
	3. Debit/Credit	
	F12=Cancel	

Command ==> \_\_\_\_\_  
F1=Help F3=Exit F4=Prompt F9=Command F10=Action Bar F12=Cancel PA1=Susp

The Query pull-down enables you to perform the following queries:

**1. Charge**

Used to display data from the:

**CCCTAB**

Consists of fields such as ORD Type, Charge Element, and Qualifier

**CCCMOD**

Similar to the CCCTAB table in structure but generated by the batch forecast process

**BUDTAB**

Consists of budget information, such as Budget Amount and description

**DBCRTAB**

Consists of debit and credit information

Charge query also allows you to save favorite queries for reuse.

**Note:** It is important to remember that the CCCTAB is a **summary** table of detail records. The results of query execution are, therefore, also summary data.

**2. Budget**

Use this function to query only the contents of the BUDTAB.

**3. Debit/Credit**

Use this function to query only the contents of the DBCRTAB table.

**Note:** To see a complete listing of all the fields in the CCCTAB, CCCMOD, BUDTAB, and DBCRTAB tables, refer to Appendix A.

The remainder of this chapter describes each of these functions.

## Charge Query Panels

Charge Query panels allow you to query the contents of the CCCTAB, CCCMOD, BUDTAB, and DBCRTAB tables. Using the prompts provided on each panel, you can:

- Create an SQL query by simply filling in a panel
- Execute and receive the results of the query
- Optionally save the query for later use

The Charge Query panel set consists of the following:

- Charge Query Primary panel
- Charge Query List panel
- Charge Query Expanded List panel
- Charge Query Specifications panel

You can create or browse a query by using the Charge Query primary panel. This panel allows you to name and describe the query you want to create or browse. The name and description are important for later retrieval.

The Charge Query List panels allow you to select existing queries for update or reexecution.

You can specify query selection criteria using the Charge Query Specifications panel. This panel accepts entries and generates the outcome on different Results panels. The following processing options, located on the Charge Query Specifications panel (see Charge Query Specifications Panel), determine the format of results.

- Summarize
- Break
- Bud/DBCR

The table that follows shows valid selections and the types of Results panel generated.

The following table shows valid combinations for processing options and descriptions of the reports panels generated. A complete discussion of these options and sample Results panels are in Charge Query Specifications Processing Options.

Summarize	Break	Bud/DBCR	Results
N	N	N	Detail report of those records that meet any criteria specified on the Charge Query Specifications panel. CA PMA Chargeback displays <b>each record</b> separately.

Summarize	Break	Bud/DBCR	Results
Y	N	N	One page summary report of the records that meet any criteria specified on the Charge Query Specifications panel.
Y	Y	N	Summary report of records that meet any criteria specified on the Charge Query Specifications panel. Result records are broken into groups based on the Brk fields you select. CA PMA Chargeback displays each <b>group of records</b> separately.
N	N	Y	Detail report displaying charge, budget, debit, and credit information.
Y	N	Y	Summary report of charge, budget, debit, and credit information.
Y	Y	Y	Summary-with-breaks report of charge, budget, debit, and credit information. CA PMA Chargeback summarizes results based on the fields selected in the Brk column.

## Charge Query Primary Panel

You use this panel to specify a charge query that you want to define, browse or modify. The panel below shows how to create a new query **CPUCOST** with description **CPU COST FOR PER. 1-3**. When you press F2 (Create), you go to the Charge Query Specifications panel (see Charge Query Specifications Panel) where you can define the charge query.

**Note:** All user entries are converted to uppercase by CA PMA Chargeback.

USERID	CA PMA Chargeback	MM/DD/YY HH:MM:SS
Acctdefs	Query Data Period	Options Exit Help
+-- CBQQRYP ---- Charge Query -----+		
Panel Exit Help		
-----		
Type information. Then select an action.		
-----		
Query . . . . CPUCOST		
Description . CPU COST FOR PER.1-3		
-----		
F2=Create F11=Browse		
+-----+		
Command ==> _____		
F1=Help F3=Exit F4=Prompt F9=Command F10=Action Bar F12=Cancel PA1=Susp		

If you want to browse **all** existing queries, enter the SQL wildcard character (%) in the Query field and press F11. This displays a list of available queries and their descriptions. You can then select an item for further examination.

If you want to browse existing queries that meet a specific criteria, you can specify selection criteria in the Query field and press F11. This displays a list of only those query names that meet the specified criteria. You can select the query names for further processing.

**Note:** In any user entry field, you can use the SQL wildcard character % to represent characters that are not known.

Next is a description of the Charge Query primary panel.

### Access

The Charge Query primary panel appears when one of these events occur:

- You type QC in the fast path area of the Primary Panel's action bar.
- You choose Charge Query on the Query pull-down.
- You return from the Charge Query List, or Charge Query Specifications panels.

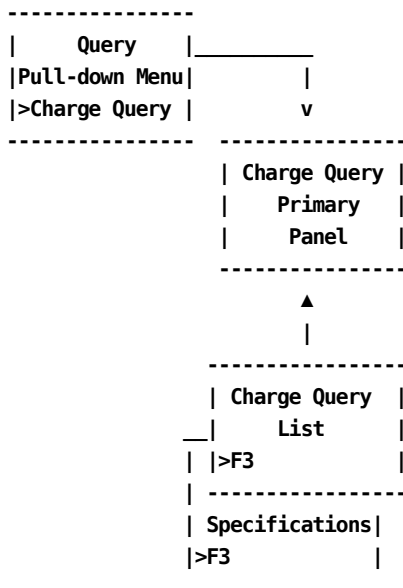

**Input**

The following Charge Query primary panel fields are available for input:

**Query**

The browse criteria or the name of a new query you want to create. Entries consist of up to 8 alphanumeric characters.

**Description**

A field (up to 20 alphanumeric characters) used to describe what the query does. If the query already exists and you want to browse or reexecute it, you can leave the field blank.

**Pathways**

**F2**

**(Create)** Takes you to the Charge Query Specifications panel (section Charge Query Specifications Panel).

**F11**

**(Browse)** Takes you to the Charge Query List panel (section Charge Query List Panel).

## Charge Query List Panel

The Charge Query List panel displays a list of query names and descriptions that already exist. These queries can be executed, browsed, or updated. You make a selection by placing the cursor next to the query name you want to view and pressing the **Enter** key. If you specified a query browse criterion on the Charge Query primary panel, CA PMA Chargeback redisplay it as a protected field.

```

USERID                                CA PMA Chargeback                MM/DD/YY HH:MM:SS
__  Acctdefs  Cbdefs  Query  Data  Period  Options  Exit  Help

+-- CBQRYL -- Charge Query List -----+
|                                     |
|   Panel  Exit  Help                 |
|-----|                             |
| Select a query name. Then Enter.    |
| Query . . . :%                      |
|                                     |
|           More: - + DATA Row   1 of 5 |
| Charge Query      Query Description   |
| CPUCOST           CPU COST FOR PER.1-3 |
| DEVCOST           COST FOR DIV. DEV.   |
| DISKCHG           CHG FOR DISK USAGE   |
| RESAVG            AVG COST FOR REST    |
|                                     |
| Enter  F7=Bkwd  F8=Fwd  F11=Expand   |
|-----+-----|
Command ==> _____
F1=Help  F3=Exit  F4=Prompt  F9=Command  F10=Action Bar  F12=Cancel  PA1=Susp

```

The following is a description of the Charge Query List panel.

### Access

The Charge Query List panel appears when one of these events occur:

- You press **F11** on the Charge Query Primary panel shown in Charge Query Primary Panel.
- You return from the Expanded Charge Query List or Charge Query Specifications panels.

```

-----
| Charge Query | _____ |
|   Primary   |           |
|>F11        |           |
|-----|-----|
|           | Charge Query |
|           |   List     |
|           |   Panel   |
|-----|-----|
                ▲

```

```
      |  
      |  
-----  
| Charge Query |  
| Specifications|  
|>F3          |  
-----
```

### Scrolling

F7 and F8 let you scroll backward and forward through the Charge Query List panel. The scroll bar can also be used to move throughout the text (see page Sample List Panel).

### Pathways

#### Enter

By placing the cursor next to a specific Charge Query and pressing **Enter**, you go to the Charge Query Specifications panel (shown in Charge Query Specifications Panel) to examine and optionally update the query.

#### F11

**(Expand)** Provides you with an **expanded** (eight-line display) view of the Charge Query List panel.

## Expanded Query List Panel

CA PMA Chargeback displays the following panel when you press **F11** (Expand) on the Charge Query List panel (see Charge Query List Panel). The only difference between these two panels is that the Expanded Query List panel does not display the Query protected field. This allows you to view more information on a single panel.

```

USERID                                CA PMA Chargeback                                MM/DD/YY HH:MM:SS
---  Acctdefs  Cbdefs  Query  Data  Period  Options  Exit  Help
+-- CBQORYX - Expanded Query List -----+
   Panel  Exit  Help
+-----+
| Select a query name. Then Enter.
|
|           More: - + DATA  Row   1 of   5
| Charge Query      Query Description
| CPUCOST           CPU COST FOR PER.1-3
| DEVCOST           COST FOR DIV. DEV.
| DISKCHG           CHG FOR DISK USAGE
| RESAVG            AVG COST FOR REST
| TAPECHG           CHG FOR TAPE USAGE
|
| Enter  F7=Bkwd  F8=Fwd
+-----+
Command ==>
F1=Help  F3=Exit  F4=Prompt  F9=Command  F10=Action Bar  F12=Cancel  PA1=Susp

```

## Charge Query Specifications Panel

The Charge Query Specifications panel allows you to formulate new queries or change/execute existing ones. You specify the query selection criteria and the manner in which you want results displayed.

The following sample Charge Query Specifications panel shows the default values that appear when you select the panel for the first time for a new query. CA PMA Chargeback displays the name of the query and its description as entered in the Charge Query Primary panel, or as retrieved from a saved definition on the first line after the panel action bar.

```

USERID              CA PMA Chargeback              MM/DD/YY HH:MM:SS
----- Acctdefs  Cbdefs  Query  Data  Period  Options  Exit  Help
+--- CBQQRYS ----- Charge Query Specifications -----
|
| Panel  Exit  Help
|-----
| Type information for Query CPU COST  Desc CPU COST FOR PER.1-3  Table TAB
|
| Summarize N  Break N  Bud/DBCR N  D. B.  Version : PROD PROD
| A. |                Brk  Srt
| ORD Type . . . .                N  Rec Count      B.      > SUM
| Charge Element .                N  Units . .      > SUM
| Qualifier . . . .                N  Rate . . .    > AVG
| Period Number .                thru B. N  Charge . .    C.      > SUM
| DIVISION . . . .                N
| DEPARTMENT . . .                N
|
| F2=Exec  F5=Save  F6=Delete  F11=Refresh
|-----
| Command ==>
| F1=Help  F3=Exit  F4=Prompt  F9=Command  F10=Action Bar  F12=Cancel  PA1=Susp

```

The Version field displays the CA PMA Chargeback version in use. Only the last four characters of the version field are available for entry. The default is the version specified on the Primary Panel's Option function. All other fields are available for entry.

Once you specify the query requirements, CA PMA Chargeback displays results on one of three different types of Charge Query Results panels:

- Summary
- Summary-with-Breaks
- Detail

See Charge Query Specifications Processing Options through Charge Query Specifications Processing Options for more information about the Charge Query Results panels.

The following is a description of the Charge Query Specifications panel.

**Access**

The Charge Query Specifications panel appears when one of these events occur:

- You create a new query on the Charge Query Primary panel shown in Charge Query Primary Panel.
- You make a selection on the Charge Query List or Expanded List panel.
- You return from any of the Charge Query Results panels.

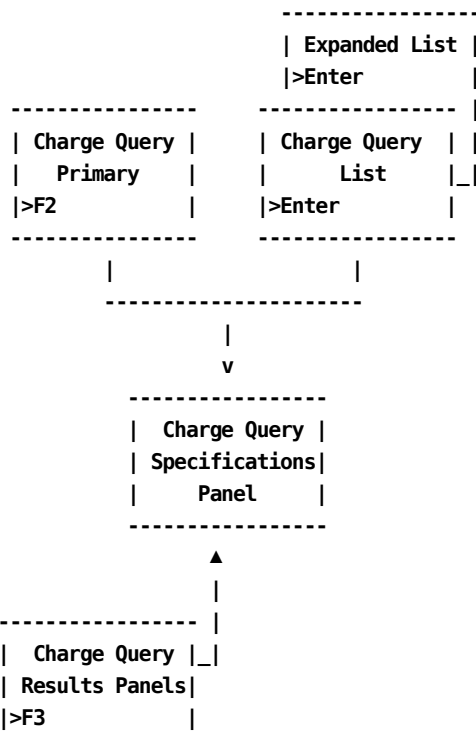

**Input:**

The following Charge Query Specification panel fields are available for input. These input fields refer to the sample panel in Charge Query Specifications Panel.

**Note:** The following discusses input fields by the function they perform and **not** in the order the cursor moves.

**A.**

**Display Options**

Summarize A one-character field that works with the Break field to determine the format of results. Valid entries for this field are N(no) and Y(yes). The default value is N and appears when you first select the panel.

When you set the Summarize option to N, results display in detail form (see Charge Query Specifications Processing Options). When you set the Summarize option to Y, results display in summary form, or in summary-with-breaks form (see Charge Query Specifications Processing Options through Charge Query Specifications Processing Options).

Break A one-character field that works with the Summarize field to determine result format. Valid entries for this field are N and Y. The default value is N and appears when you first select the panel.

When you set the Break field to Y, the Brk column becomes active (see D.)

**Note:** At least one field in the Brk column must be set to Y when you select the Break option. Otherwise, CA PMA Chargeback returns an error message.

If you do not set the Break field to Y, CA PMA Chargeback ignores any value entered in the Brk column.

The Break field cannot be set to Y without setting the Summarize field to Y. The application returns an error message if you attempt this action.

Bud/DBCR A one-character flag that allows CA PMA Chargeback to display budget, debit, and credit, as well as charge information based on any criteria you specify (see page Charge Query Specifications Processing Options). Valid entries for this field are Y and N. The default value is N and appears when you first select the panel.

Srt CA PMA Chargeback displays results in the order specified by the selected fields. To select a field, enter a Y in the Srt column next to the field. (Sort priority is from top to bottom in the Srt column.)

**B.**

**Selection Criteria**

**Note:** You can use the SQL wildcard character % alone or with any alphanumeric character string as selection criteria for these fields. If a field is left blank, then all values for the field are accepted.

Version The last four characters of this field are available for data entry. Specify the version of CA PMA Chargeback you want to query.

ORD Type The three-character name of the output record identifier used as selection criteria. CA PMA Chargeback processes only those records with the ORD Type you specify.

Charge Element The name (up to 16 alphanumeric characters) of the Charge Element used for selection criteria. Only those records with the Charge Element you specify display.

Qualifier The name (up to 16 alphanumeric characters) of the conditional test applied to the charge unit, used for selection criteria. CA PMA Chargeback selects only those records to which the qualifier applies.

Period Number The start of the range of accounting periods or the accounting period from which CA PMA Chargeback selects records.

thru The end of the range of accounting periods from which CA PMA Chargeback selects records.

Entering data in these fields in the following manner provides you with the following results:

<b>Period Number</b>	<b>thru</b>	<b>Result</b>
___	___	List of all records that meet the rest of the criteria specified
001	006	List of all records in periods 001 thru 006 that meet the criteria specified
001	___	List of all records in period 001 that meet the criteria specified
___	006	Invalid; you will get an error message

Table The table from which CA PMA Chargeback retrieves records. Valid entries are TAB for the CCCTAB table, or MOD for the CCCMOD table.

**Note:** When you request information from the MOD table, the Bud/DBCR option is invalid.

The following entry fields indicate the accounting structures you want to query.

**Note:** CA PMA Chargeback displays only defined accounting structures. The examples displayed in this chapter show an accounting structure with two levels. The accounting structures you define can be different.

Division Department Enter the name of a defined accounting level whose charge, budget, debit or credit information you want to query.

**C.**

**Selection Criteria/Display Options**

The Rec Count, Units, Rate, and Charge fields allow you to specify:

- Any query criteria
- The valid SQL summary options (**Sum, Min, Max, Avg**) performed on result records

When specifying query selection criteria, enter only **numeric** values in these fields. You must specify a comparison operator (<, >, =) in the Op column (see E in Charge Query Specifications Panel).

- To select **all** records, do not specify query criteria within the Rec Count, Units, Rate, or Charge fields. Then the Op column is invalid.
- If you specify query criteria but do not specify an operator in the Op column, CA PMA Chargeback uses the default > for comparisons.

If you request a summary, or a summary-with-breaks report, CA PMA Chargeback activates the Sum column (see F in Charge Query Specifications Panel). This allows you to specify an SQL summary option to be performed on result records.

Rec Count

Units

Rate

Charge Enter a numeric value and an arithmetic operator, and/or change the default SQL function if Summarize is Y. The SQL functions are by default SUM, SUM, AVG, SUM.

The following table gives examples of how selection criteria specified within the Rec Count, Units, Rate and Charge fields work. The table also shows how specifying valid SQL functions in the Sum column for these fields affects results.

Fields	Criteria	Op	SQL Functions	Results
--------	----------	----	---------------	---------

Fields	Criteria	Op	SQL Functions	Results
Rec Count	2	>	AVG	CA PMA Chargeback averages the values within the Rec Count field for those records where Rec Count > 2.
Units	50	=	SUM	CA PMA Chargeback sums the values within the Units field for those records where Units = 50.
Rate	.5	<	MIN	CA PMA Chargeback computes the minimum rate of those records where Rate < .5.
Charge	200	>	MAX	CA PMA Chargeback computes the maximum charge of those records where Charge > 200.
Charge			SUM	CA PMA Chargeback sums all charge values for the selected records.

#### Actions

##### F2=Exec

Executes the query for the requested selections from the panel.

##### F5=Save

Saves all query information on the panel.

##### F6=Delete

Lets you delete data from the saved query table.

##### F11=Refresh

Resets the screen to the original entry state for existing queries.

## Charge Query Specifications Processing Options

Located on the second line of the Charge Query Specifications Panel are three processing options:

- Summarize
- Break
- Bud/DBCR

These options determine the type of report that CA PMA Chargeback generates. The Summarize and Break fields work in unison and allow results to be displayed in three different types of formats:

- Summary
- Summary-with-Breaks
- Detail

The Bud/DBCR field, when set to Y, allows budget, debit, and credit information to display along with charge results. CA PMA Chargeback displays budget, debit, and credit results in one of the above formats. If Bud/DBCR is set to N, CA PMA Chargeback displays the budget, debit, and credit fields without any data.

- **Summary Report (Summarize=Y, Break=N)**

When you set the summarize option to Y and the Break option to N in the Charge Query Specifications panel, CA PMA Chargeback summarizes the result fields of the records which meet query criteria. It then displays these results as a one-page summary report.

CA PMA Chargeback determines the values of the result fields: Rec Count, Units, Rate, and Charge by using the SQL functions specified in the Sum column of the Charge Query Specifications panel. The result fields can hold a summation, average, minimum, or maximum of the selected records. To change the default SQL functions for these result fields, specify a new function for the default displayed on the Charge Query Specifications panel. Valid choices are:

- SUM
- AVG
- MIN
- MAX

To select a summary report set the Summarize option to Y as shown on the panel below.

```

+-- CBQQRYS ----- Charge Query Specifications -----+
| Panel Exit Help                                     |
+-----+
| Type information for Query CPUCOST Desc CPU COST FOR PER.1-3 Table TAB |
| Summarize Y Break N Bud/DBCR N Version : PROD PROD |
| Brk Srt Op Sum |
| ORD Type . . . . N Rec Count > SUM |
| Charge Element . N Units . . > SUM |
| Qualifier . . . . N Rate . . . > AVG |
| Period Number . thru N Charge . . > SUM |
| DIVISION . . . . N |
| DEPARTMENT . . . N |
+-----+
    
```

After pressing F2 (Exec), the following Charge Query Results panel appears. Note the following:

- The first column reiterates the values on the Charge Query Specifications panel.
- The values in the Record Count, Units, and Charge fields are summations of the Record Count, Units, and Charge of the records meeting the criteria specified in the Charge Query Specifications panel (see A., B, and D below).
- The Rate field is an average Rate of the records meeting the criteria specified in the Charge Query Specifications panel (see C below).
- Since there is no query criteria, CA PMA Chargeback selects and summarizes **all** records from the CCCTAB. See Example 1: Entering Selection Criteria Within the Charge Element Field for an example of a summary report with selection criteria.

```

USERID          CA PMA Chargeback          MM/DD/YY HH:MM:SS
__ Acctdefs    Cbdefs  Query Data Period Options Exit Help

+-- CBQQRYZ ----- Charge Query Results -----+
| Table . . . . . : TAB |
| Version . . . . . : PROD PROD | Record Count : 177 A. | | | |
| ORD Type . . . . . : | Units . . . . . : 91.16665 B. |
| Charge Element . . : | Rate . . . . . : 185.95238 C. |
| Qualifier . . . . . : | Charge . . . . . : 22861.99500 D. |
| Period Number . . : thru | Debit Amt . . : |
| DIVISION . . . . . : | Credit Amt . . : |
| DEPARTMENT . . . . : | Adjust Charge: |
| | | | | Budget . . . . : |
| | | | | % of Budget : |
+-----+
Command ==>
F1=Help F3=Exit F4=Prompt F9=Command F10=Action Bar F12=Cancel PA1=Susp
    
```

■ **Summary-with-Breaks Report (Summarize=Y Break=Y)**

If you select both the Summarize and Break options, CA PMA Chargeback displays the result fields of the selected records in summary format. However, in contrast to a Summary report, result records are broken into **groups**. CA PMA Chargeback groups the records with identical values in the fields selected in the Brk column of the Charge Query Specifications panel. It displays the result fields for each group separately.

Depending upon the function you specify in the Sum column, CA PMA Chargeback:

- Summarizes
- Averages
- Minimizes
- Maximizes

the result fields Rec Count, Units, Rate, and Charge for each group of records. The scroll bar denotes the number of groups available for viewing.

**Remember** if you set the Break option to Y, you **must** set at least one field in the Brk column to Y.

To generate a summary-with-breaks report and change the default SQL function SUM, to AVG within the Units field, do the following:

- Set the Summarize and Break fields to Y (see A below)
- Select Brks for ORD Type and Charge Element (see B below) by entering Y in the Brk column
- Change SUM to AVG in the Sum column (see C below)

```

USERID          CA PMA Chargeback          MM/DD/YY HH:MM:SS
  Acctdefs      Cbdefs  Query  Data  Period  Options  Exit  Help
-----
+-+ CBQQRYS ----- Charge Query Specifications -----+
  Panel  Exit  Help
-----+-----
Type information for Query CPUCOST  Desc CPU COST FOR PER.1-3  Table TAB
  A.
Summarize Y  Break Y  Bud/DBCR N          Version : PROD PROD
ORD Type . . . .          Y  Brk Srt          Op Sum
Charge Element .          Y B. Units . . . .      > AVG C.
Qualifier . . .          N  Rate . . . .      > AVG
Period Number .          thru  N  Charge . . . .      > SUM
DIVISION . . . .          N
DEPARTMENT . . . .          N

  F2=Exec  F5=Save  F6=Delete  F11=Refresh
-----+-----
Command ==>
F1=Help  F3=Exit  F4=Prompt  F9=Command  F10=Action Bar  F12=Cancel  PA1=Susp
    
```

The next panel shows two rows of results (see 1 and 2). Note the following:

- CA PMA Chargeback summarizes and displays each unique combination of ORD Type and Charge Element separately. **Three** groups of records result (see A below).
- Values within the Record Count and Charge fields are total Record Count and Charge values for the records in the group (see B and D below).
- Values within the Units and Rate fields are an average of the units and rates of the records in the group (see C below).

**Note:** In a summary-with-breaks report, CA PMA Chargeback displays any SQL function applied to the Record Count, Units, Rate, or Charge fields, other than SUM (see C below).

```

+-- CBQORYB ----- Charge Query Results -----+
|      Panel  Exit  Help                      1.      |
|-----|
|                                     More: + - 1   Row: 0001 of 0003 |
| Table . . . . . : TAB                                A.      |
| Version . . . . . : PROD PROD      Record Count : B.          134  |
| ORD Type . . . . . : MBJ           Units . . . . . : C.    4.00980 AVG |
| Charge Element . . : CPU-CHARGE    Rate . . . . . :          159.05882 AVG |
| Qualifier . . . . . :              Charge . . . . . : D. 14459.99500 |
| Period Number . . :              Debit Amt . . . :              |
| DIVISION . . . . . :              Credit Amt . . . :              |
| DEPARTMENT . . . . :              Adjust Charge:              |
|                                     Budget . . . . :              |
|                                     % of Budget . . . :              |
|
  
```

```

+-- CBQORYB ----- Charge Query Results -----+
|      Panel  Exit  Help                      2.      |
|-----|
|                                     More: + - 1   Row: 0002 of 0003 |
  
```

Table . . . . . : TAB	A.	
Version . . . . . : PROD PROD	Record Count : B.	42
ORD Type . . . . . : MBJ	Units . . . . . : C.	7.00000 AVG
Charge Element . . : CPX-CHARGE	Rate . . . . . :	400.00000 AVG
Qualifier . . . . . :	Charge . . . . . : D.	8400.00000
Period Number . . :	Debit Amt . . :	
DIVISION . . . . . :	Credit Amt . . :	
DEPARTMENT . . . . :	Adjust Charge:	
	Budget . . . . :	
	% of Budget . . :	
F7=Bkwd F8=Fwd		
+-----+		

■ **Detail Report (Summarize=N, Break=N)**

If you do **not** select the Summarize and Break options, you receive a detail report of the records within the CCCTAB or CCCMOD tables that meet any selection criteria. CA PMA Chargeback displays all fields of the selected records individually. The scroll bar denotes the number of records available for viewing.

In the next example, CA PMA Chargeback displays all the fields of the CCCTAB table since this is a detail report. All the records of the CCCTAB table are displayed because there is no query criteria. The CCCTAB contains 21 rows. The example below shows two of these records.

Note the two additional fields on the Detail Charge Query Results panel:

**A.**

If a value appears for the **Modifier** field, the record is a modified record.

**B.**

**Split/Modified** is a two-character flag. The first character indicates whether the record has a split charge associated with it. The second character indicates whether the record has been modified.

+-- CBQORYD ----- Charge Query Results -----+		
	Panel Exit Help	1.

-----		
Table . . . . . : TAB	More: + - 1	Row: 0001 of 0021
Version . . . . . : PROD PROD		
ORD Type . . . . . : MBJ	Record Count :	1
Charge Element . . : CPU-CHARGE	Units . . . . :	1.00000
Qualifier . . . . . : SHIFT1	Rate . . . . . :	.50000
Period Number . . : 1	Charge . . . . :	.50000
A.Modifier . . . . . : WEEKEND	Debit Amt . . :	
B.Split/Modified . . : NY	Credit Amt . . :	
DIVISION . . . . . : RESTON	Adjust Charge:	
DEPARTMENT . . . . : TECHWRIT	Budget . . . . :	
	% of Budget :	

+-- CBQQRYD ----- Charge Query Results -----+		
Panel	Exit	Help
		2.
-----		
Table . . . . . : TAB	More: + - 1	Row: 0002 of 0021
Version . . . . . : PROD PROD		
ORD Type . . . . . : MBJ	Record Count :	1
Charge Element . . : CPU-CHARGE	Units . . . . :	2.00000
Qualifier . . . . . : SHIFT1	Rate . . . . . :	.50000
Period Number . . : 2	Charge . . . . :	1.00000
A. Modifier . . . . . : WEEKEND	Debit Amt . . :	
B. Split/Modified . . : NY	Credit Amt . . :	
DIVISION . . . . . : RESTON	Adjust Charge:	
DEPARTMENT . . . . : TECHWRIT	Budget . . . . :	
	% of Budget :	

	F7=Bkwd F8=Fwd	
+-----+		

■ **Bud/DBCR**

The Bud/DBCR option displays budget, debit and credit information in the format specified using the Summarize and Break fields. If you specify selection criteria on the Charge Query Specifications panel, CA PMA Chargeback displays budget, debit, and credit information for only those records that meet the criteria.

**Note:** Using the Bud/DBCR option adds to the processing requirements of the query, and should not be used as a matter of course.

The following fields contain budget, debit, and credit information on the Result panels.

**Debit Amt**

The amount by which CA PMA Chargeback reduces the Charge value.

**Credit Amt**

The amount by which CA PMA Chargeback increases the Charge value.

**Adjust Charge**

The charge derived by subtracting the Debit Amt and adding the Credit Amt to the Charge value.

**Budget**

The budget amount allocated for the specified record.

**% of Budget**

The percentage of budget used up to this point.

The example below shows how to select budget, debit, and credit information in a detail report:

- Set the Summarize and Break fields to N
- Set the Bud/DBCR option to Y

```

+-----+
| Type information for Query CPUCOST Desc CPU COST FOR PER.1-3 Table TAB |
| Summarize N Break N Bud/DBCR Y Version : PROD PROD |
| Brk Srt Op Sum |
| ORD Type . . . . N Rec Count > SUM |
| Charge Element . N Units . . > SUM |
| Qualifier . . . . N Rate . . . > AVG |
| Period Number . thru N Charge . . > SUM |
| DIVISION . . . . N |
| DEPARTMENT . . . N |
| F2=Exec F5=Save F6=Delete F11=Refresh |
+-----+
    
```

The next panel shows the results of this query.

The result of this query is a detail report with the Debit Amt, Credit Amt, Adjust Charge, Budget, and % of Budget fields displaying values based on the result records selected during query execution. Note the following:

- CA PMA Chargeback displays all the **fields** of the CCCTAB table, since this is a detail report. Because we did not specify selection criteria, CA PMA Chargeback displays all of the **records** of the CCCTAB table. The example below shows two of these records.
- For Period Number 1 (see A below), the application applied no debits or credits. Therefore, the adjusted charge value is equal to the charge value (see B below).
- The Budget amount for the Techwrit department for the Period 1 and Charge Element CPU-CHARGE is -50 (see C below). Department Techwrit used only .01% of their budget allocation (see D below).

```

+--- CBQORYD ----- Charge Query Results -----+
| Panel Exit Help 1. |
| ----- |
| Table . . . . . : TAB More: + - 1 Row: 0001 of 0021 |
| Version . . . . . : PROD PROD |
| ORD Type . . . . . : MBJ Record Count : 1 |
| Charge Element . : CPU-CHARGE Units . . . : 1.00000 |
| Qualifier . . . . : SHIFT1 Rate . . . . . : .50000 |
| Period Number .A.: 1 Charge . . . . . : .50000 |
| Modifier . . . . . : WEEKEND Debit Amt . . : 0.00000 |
| Split/Modified . : NY Credit Amt .B.: 0.00000 |
    
```

	DIVISION . . . . :	RESTON	Adjust Charge:	0.50000	
	DEPARTMENT . . . :	TECHWRIT	Budget . . .C.:	50.00000	
			% of Budget :D.	.01000	

+-- CBQORYD ----- Charge Query Results -----+					
	Panel	Exit	Help	2.	
-----					
	Table . . . . . :	TAB	More: + - 1	Row: 0002 of 0021	
	Version . . . . . :	PROD PROD			
	ORD Type . . . . . :	MBJ	Record Count :	1	
	Charge Element . :	CPU-CHARGE	Units . . . . :	2.00000	
	Qualifier . . . . :	SHIFT1	Rate . . . . . :	.50000	
	Period Number A.. :	2	Charge . . . . :	1.00000	
	Modifier . . . . . :	WEEKEND	Debit Amt . . :	0.50000	
	Split/Modified . :	NY	Credit Amt B. :	0.00000	
	DIVISION . . . . :	RESTON	Adjust Charge:	0.50000	
	DEPARTMENT . . . :	ACCOUNTING	Budget . . C. :	50.00000	
			% of Budget D. :	.01000	
	F7=Bkwd	F8=Fwd			
+-----+					

## Charge Query Specifications Entry Field Options

CA PMA Chargeback supports standard SQL queries. The format of the SQL query is:

**SELECT** fieldname **FROM** tablename **WHERE** (condition) {**ORDER BY** fields}

The following sections discuss how to use the various entry fields with the processing options to generate SQL queries that:

- **SELECT** fields from the CCCTAB or CCCMOD tables (see A below)
- Choose a table to retrieve information **FROM** (see B below)
- Choose only select records for viewing **WHERE (HAVING)** certain conditions are true (see C and D below)
- Optionally view results in a particular order (see E below)

```

USERID                                CA PMA Chargeback                                MM/DD/YY HH:MM:SS
__  Acctdefs  Cbdefs  Query  Data  Period  Options  Exit  Help

+-- CBQQRYS ----- Charge Query Specifications -----+
| Panel  Exit  Help                                     B.--
|-----+-----+-----+-----+-----+-----+-----+
| Type information for Query CPUCOST   Desc CPU COST FOR PER.1-3   Table TAB
| Summarize N  Break N  Bud/DBCR N  A.  E.  Version : PROD PROD
|                               Brk Srt
| ORD Type . . . . .           N    Rec Count
| Charge Element .           N    Units . . .   D.
| Qualifier . . . .           N    Rate . . .
| Period Number .           thru  C.  N    Charge . .
| DIVISION . . . .           N
| DEPARTMENT . . . .         N
|
| F2=Exec  F5=Save  F6=Delete  F11=Refresh
+-----+-----+-----+-----+-----+-----+
Command ==>
F1=Help  F3=Exit  F4=Prompt  F9=Command  F10=Action Bar  F12=Cancel  PA1=Susp
  
```

In the following sections, each entry option is discussed and then followed by usage example(s).

## Entry Field Options: SELECT (fieldname)

You can select fields for viewing from the CCCTAB or CCCMOD tables in one of two ways:

- Detail report
- Summary-with-breaks report

If you select a detail report, CA PMA Chargeback displays all fields of the records from the CCCTAB or CCCMOD tables that meet query criteria. To generate a detail report, set the Summarize field to Y and the Break field to N.

If you select a summary-with-breaks report, CA PMA Chargeback groups results based on the fields you select in the Brk column. To select the fields CA PMA Chargeback groups records from the CCCTAB or CCCMOD tables, enter Y in the appropriate row in the Brk column. The default value is N. Make sure you set the Break field to Y. Otherwise, CA PMA Chargeback ignores values entered in the Brk column.

**Note:** You **cannot** select the Break option without also selecting the Summarize option. Attempting such an action results in an error message.

### Example 1: Grouping CCCTAB or CCCMOD fields

To select fields for viewing in a summary-with-breaks report:

- Set the Summarize and Break fields to Y (see A below)
- Enter Y in the Brk column for the ORD Type and Charge Element fields (see B below)

```

+-----+
| Type information for Query CPUCOST Desc CPU COST FOR PER.1-3 Table TAB |
| Summarize Y Break Y Bud/DBCR N Version : PROD PROD |
| A. Brk Srt Op Sum |
| ORD Type . . . . Y Rec Count > SUM |
| Charge Element . B. Y Units . . > SUM |
| Qualifier . . . . N Rate . . . > AVG |
| Period Number . thru N Charge . . > SUM |
| DIVISION . . . . N |
| DEPARTMENT . . . . N |
| F2=Exec F5=Save F6=Delete F11=Refresh |
+-----+
    
```

The panel below shows the results of selecting fields ORD Type and Charge Element for viewing. Note the following:

- There are three distinct combinations of ORD Type and Charge Element (see A below). CA PMA Chargeback displays each group separately. The groups shown below are those records where ORD Type = MBJ and Charge Element = CPU-CHARGE (see B and C below).
- The Record Count, Units, and Charge fields D, E, and G below are summations of the Record Count, Units, and Charge values for those records where ORD Type = MBJ and Charge Element = CPU-CHARGE.
- The Rate field (see F below) is an average rate of those records where ORD Type = MBJ and Charge Element = CPU-CHARGE.

```

+-- CBQRYB ----- Charge Query Results -----+
| Panel Exit Help |
| -----A----- |
| More: + - 1 Row: 0001 of 0003 |
| Table . . . . : TAB |
| Version . . . . : PROD PROD Record Count : 134 D. |
| ORD Type . . . . : MBJ B. Units . . . : 68.16665 E. |
| Charge Element . : CPU-CHARGE C. Rate . . . : 159.05882 AVG F. |
| Qualifier . . . : Charge . . . : 14459.99500 G. |
| Period Number . : Debit Amt . : |
| DIVISION . . . : Credit Amt . : |
| DEPARTMENT . . . : Adjust Charge: |
| Budget . . . : |
| % of Budget : |
| F7=Bkwd F8=Fwd |
+-----+
    
```

### Entry Field Options: FROM (tablename)

The CCCTAB and the CCCMOD tables contain the charge query information. The CCCMOD table mirrors the CCCTAB table in format. However, CA PMA Chargeback generates the CCCMOD table during **batch** forecasting.

You select one of the two tables by specifying TAB for CCCTAB or MOD for CCCMOD in the Table field of the Charge Query Specifications panel. If you do not specify a value, CA PMA Chargeback uses the default: TAB.

**Note:** When you select the CCCMOD table, the Bud/DBCR option is invalid.

### Entry Field Options: WHERE (condition)

If you wish to select only those records that meet a specific criteria, you can add a conditional test next to any of the panel fields. This test can be a predefined user name, a number, or a number to be used with a comparison operator (<, >, =) specified in the Op column. The following table shows valid criteria for each of the entry fields:

Entry Field	Type of Criteria
ORD Type	Predefined user name
Charge Element	Predefined user name
Qualifier	Predefined user name
Period Number	Number (up to 3 digits)
Accounting Structure (1 - 5)	Predefined accounting level
Rec Count	Number and comparison operator in Op column
Units	Number and comparison operator in Op column
Rate	Number and comparison operator in Op column
Charge	Number and comparison operator in Op column

**Note:** If you request a summary or a summary-with-breaks report, specifying selection criteria within the Rec Count, Units, Rate, and Charge fields causes the generation of a SQL **HAVING** clause instead of a WHERE clause. The SQL HAVING clause is similar to SQL WHERE clause, but qualifies groups rather than individual fields.

CA PMA Chargeback can display results in any format, regardless of the criteria you specify. The examples that follow show summary and summary-with-breaks reports.

### Example 1: Entering Selection Criteria Within the Charge Element Field

To select the records that meet the criterion Charge Element = CPU-CHARGE and display results in a summary report:

- Set the Summarize field to Y (see A below)
- Specify CPU-CHARGE in the area next to Charge Element (see B below)

```
+-- CBQQRYZ ----- Charge Query Specifications -----+
|   Panel  Exit  Help
|-----|
| Type information for Query CPUCOST  Desc CPU COST FOR PER.1-3  Table TAB
|-----|
| Summarize Y  Break N  Bud/DBCR N          Version : PROD PROD
|   A.
| ORD Type . . . . .      N      Rec Count          Op Sum
| Charge Element . CPU-CHARGE  B.  N      Units . . .      > SUM
| Qualifier . . . . .      N      Rate . . . .      > AVG
| Period Number . . . . . thru  N      Charge . . . .      > SUM
| DIVISION . . . . .      N
| DEPARTMENT . . . . .      N
|-----|
+-----+
```

The next panel shows the **results** of entering CPU-CHARGE in the Charge Element field. Note the following:

- CA PMA Chargeback summarizes only those records in the CCCTAB table where Charge Element = CPU-CHARGE.
- The Record Count, Units, and Charge fields show the total amount of record count, units, and charges of those records where Charge Element = CPU-CHARGE (see A, B, and D below).
- The Rate field shows the average rate of the resulting records (see C below).

```
+-- CBQQRYZ ----- Charge Query Results -----+
|   Panel  Exit  Help
|-----|
| Table . . . . . : TAB          More: + - 1      Row: 0001 of 0001
| Version . . . . . : PROD PROD      Record Count :          134  A.
| ORD Type . . . . . :              Units . . . . . :       68.16665  B.
| Charge Element . . : CPU-CHARGE     Rate . . . . . :       159.05882  AVG C.
| Qualifier . . . . . :              Charge . . . . . :      14459.99500  D.
| Period Number . . . :              Debit Amt . . . :
| DIVISION . . . . . :              Credit Amt . . . :
| DEPARTMENT . . . . . :             Adjust Charge:
|                                     Budget . . . . :
|                                     % of Budget :
|
| F7=Bkwd  F8=Fwd
|-----|
+-----+
```

### Example 2: Entering Selection Criteria within the Period Number Field

To select the records that meet the criterion Period Number > = 001 and < 003 in a summary-with-breaks report:

- Set the Summarize and Break fields to Y (see A below)
- Enter 001 in the first field for Period Number and 003 in the second field (see B below)
- Set the Brk field next to Period Number to Y, so that results display by period number (see C below)

```
+-----+
| Type information for Query CPUCOST   Desc CPU COST FOR PER.1-3   Table TAB |
|           A.                                                                |
| Summarize Y  Break Y  Bud/DBCR N           Version : PROD PROD         |
| ORD Type . . . . .                N   Rec Count                    Op Sum |
| Charge Element . . . . .           N   Units . . .                > SUM |
| Qualifier . . . . .                N   Rate . . .                 > AVG |
| Period Number . 001 thru 003 Y   C. Charge . . .                 > SUM |
| DIVISION . . . . .                 N                               |
| DEPARTMENT . . . . .               N                               |
|                                                                              |
|   F2=Exec  F5=Save  F6=Delete  F11=Refresh                             |
+-----+
```

The next panel shows the **results** of entering a numeric value in the Period Number field.

- Three groups of records meet the criteria specified: Period Number > or = 001 and Period Number < or = 003 (see A below). Row 1 on the panel below shows the group of records that fall within period 1. Rows 2 and 3 (not shown) contain those records that fall within periods 2 and 3, respectively.
- The Record Count, Units, and Charge fields show the total amount of record count, units, and charges of those records that fall in period 1 (see B, C, and E below).
- The Rate field shows the average rate of the resulting records (see D below).

```

+-- CBQRYB ----- Charge Query Results -----+
      Panel  Exit  Help
-----A-----
      More: + - 1      Row: 0001 of 0003
Table . . . . . : TAB
Version . . . . . : PROD PROD      Record Count :          2      B.
ORD Type . . . . . :                Units . . . . . :      2.00000      C.
Charge Element . . :                Rate . . . . . :          .50000      AVG D.
Qualifier . . . . . :                Charge . . . . . :      1.00000      E.
> Period Number . . : 1             Debit Amt . . :
DIVISION . . . . . :                Credit Amt . . :
DEPARTMENT . . . . :                Adjust Charge:
                                      Budget . . . . :
                                      % of Budget  :

      F7=Bkwd  F8=Fwd
-----+

```

### Example 3: Entering Multiple Selection Criteria

If you specify restrictions in more than one field on the Charge Query Specifications panel, a compound condition results. In order for CA PMA Chargeback to select a record for display, the record must meet **all** the criteria requirements.

To construct a compound condition using the entries for examples 2a and 2b:

- Set the Summarize and Break fields to Y (see A below)
- Enter CPU-CHARGE in the area next to Charge Element (see B below)
- Enter 001 in the first field for Period Number and 003 in the second field (see C below)
- Set the Brk field for Period Number and Charge Element to Y. This allows CA PMA Chargeback to display results by period and Charge Element (see D below).

```
+-----+
| Type information for Query CPUCOST Desc CPU COST FOR PER.1-3 Table TAB |
| A. |
| Summarize Y Break Y Bud/DBCR N Version : PROD PROD |
| Brk Srt Op Sum |
| ORD Type . . . . N Rec Count > SUM |
| Charge Element . CPU-CHARGE B. Y Units . . . > SUM |
| Qualifier . . . . C. N Rate . . . > AVG |
| Period Number . 001 thru 003 Y D. Charge . . > SUM |
| DIVISION . . . . N |
| DEPARTMENT . . . . N |
+-----+
```

The next panel shows the **results** of entering multiple criteria on the Charge Query Specifications panel. Note the following:

- Three groups of records meet the criteria specified (see A below). CA PMA Chargeback displays each group, representing one accounting period for Charge Element CPU-CHARGE, separately.
- The Record Count, Units, and Charge fields show totals for those records that fall in Period 1 where Charge Element = CPU-CHARGE (see B, C, and E below).
- The Rate field shows the average rate of the resulting records that fall in Period 1 where Charge Element = CPU-CHARGE (see D below).

```

+-- CBQRYB ----- Charge Query Results -----+
      Panel  Exit  Help
-----A-----
      More: + - 1      Row: 0001 of 0003
Table . . . . . : TAB
Version . . . . . : PROD PROD      Record Count :          2  B.
ORD Type . . . . . :                Units . . . . . :      2.00000  C.
Charge Element . . : CPU-CHARGE     Rate . . . . . :          .50000  AVG  D.
Qualifier . . . . . :                Charge . . . . . :          1.00000  E.
Period Number . . : 1
DIVISION . . . . . :                Debit Amt . . . :
DEPARTMENT . . . . :                Credit Amt . . . :
                                      Adjust Charge:
                                      Budget . . . . . :
                                      % of Budget :
-----+

```

### Entry Field Options: Order By

CA PMA Chargeback supports the SQL **Order By** operation. When selected, this option presents result records in the order specified by the selected Srt fields. If you select more than one field, CA PMA Chargeback gives priority to the field located higher on the Charge Query Specifications panel. To select this option, specify a Y in the Srt column corresponding to the field(s) by which you want result records displayed. If you do not make a selection, CA PMA Chargeback displays results in the same order as the fields appear on the Charge Query Specifications panel.

### Example 1: Using the Srt Option

To display the contents of the CCCTAB by Period Number:

- Set the Summarize and Break fields to N (see A. below)
- Specify Y in the Srt column next to Period Number (see B. below)

```

USERID                CA PMA Chargeback                MM/DD/YY HH:MM:SS
__  Acctdefs  Cbdefs  Query  Data  Period  Options  Exit  Help

+-- CBQQRY5 ----- Charge Query Specifications -----+
| Panel  Exit  Help                                     |
+-----+
| Type information for Query CPUCOST  Desc CPU COST FOR PER.1-3  Table TAB |
| A.                                                                              |
| Summarize N  Break N  Bud/DBCR N          Version : PROD PROD          |
| Brk Srt                                           Op Sum |
| ORD Type . . . .          N  Rec Count          > SUM |
| Charge Element .          N  Units . .          > SUM |
| Qualifier . . .          N  B. Rate . . .          > AVG |
| Period Number .          thru  N  Y Charge . .          > SUM |
| DIVISION . . .          N |
| DEPARTMENT . . .          N |
|                                                                              |
| F2=Exec  F5=Save  F6=Delete  F11=Refresh |
+-----+
Command ==>
F1=Help  F3=Exit  F4=Prompt  F9=Command  F10=Action Bar  F12=Cancel  PA1=Susp
    
```

The next panel shows the **results** of specifying a Y in the Srt column for the Period Number field. Note the following:

- CA PMA Chargeback displays the entire contents of the CCCTAB (see A. below) since there is no query criteria.
- The panel below shows the fields contained in one record of the CCCTAB table.
- CA PMA Chargeback sorts all records by Period Number. The row shown below is the first record in the CCCTAB that falls within Period 1 (see B. below).

```

USERID          CA PMA Chargeback          MM/DD/YY HH:MM:SS
__ Acctdefs   Cbdefs   Query  Data  Period  Options  Exit  Help

+-- CBQQRD ----- Charge Query Results -----+
| Panel  Exit  Help                                     A. |
|-----+-----+-----+-----+-----+-----+-----+
| Table . . . . . : TAB                More: + - 1   Row: 0001 of 0021 |
| Version . . . . . : PROD PROD                                     |
| ORD Type . . . . . : MBJ                                     Record Count :         1 |
| Charge Element . . : CPU-CHARGE          Units . . . . . :       1.00000 |
| Qualifier . . . . . : SHIFT1             Rate . . . . . :         .50000 |
| Period Number . . . : 1 B.                Charge . . . . . :         .50000 |
| Modifier . . . . . : WEEKEND             Debit Amt . . . :         |
| Split/Modified . . : NY                   Credit Amt . . . :         |
| DIVISION . . . . . : RESTON              Adjust Charge :         |
| DEPARTMENT . . . . : TECHWRIT           Budget . . . . . :         |
|                                         % of Budget :         |
|
| F7=Bkwd  F8=Fwd
|-----+-----+-----+-----+-----+-----+-----+
Command ==>
F1=Help  F3=Exit  F4=Prompt  F9=Command  F10=Action Bar  F12=Cancel  PA1=Susp

```

## Budget Query Specifications Panel

The Budget Query Specifications panel allows you to query the contents of the BUDTAB. Using the prompts provided, you can:

- Create an SQL query by simply filling in a panel
- Execute and view the results of the query

You specify query criteria and the manner in which you want results displayed. The following processing options, located on the Budget Query Specifications panel, determine result format.

- Summarize
- Break

These two options work together to display the following results.

Summarize	Break	Results
N	N	Detail report of the records that meet any criteria specified in the Budget Query Specifications panel. CA PMA Chargeback displays <b>each record</b> separately. For each record, CA PMA Chargeback provides values for the additional fields Budget Amt and Desc.

Summarize	Break	Results
Y	N	Summary report of the records that meet any criteria specified in the Budget Query Specifications panel. Result fields Budget Amt and Count appear directly on the Budget Query Specifications panel. Budget Amt and Count hold summary information.
Y	Y	Summary report of the records that meet any criteria specified in the Budget Query Specifications panel. Result records are broken into groups based on the Brk fields you select. CA PMA Chargeback displays <b>each group</b> separately. For each group of records, CA PMA Chargeback provides values for the additional fields Budget Amt and Count.

The following panel shows the Budget Query Specifications panel upon entry to Budget Query. The values shown are the defaults.

```

USERID          CA PMA Chargeback          MM/DD/YY HH:MM:SS
__  Acctdefs  Cbdefs  Query  Data  Period  Options  Exit  Help

+-- CBQBGTS -- Budget Query Specifications -----+
| Panel  Exit  Help                               |
+-----+
| Type information for budget query. Then Execute. |
| Summarize N  Break N                            |
|                                                    |
| Version : PROD PROD                             |
| Brk                                                |
| ORD Type . . . . .                             |
| Charge Element . .                               |
| Qualifier . . . . .                             |
| Period Number . . thru                          |
| DIVISION . . . . .                             |
| DEPARTMENT . . . . .                           |
|                                                    |
| F2=Exec                                          |
+-----+
Command ==>
F1=Help  F3=Exit  F4=Prompt  F9=Command  F10=Action Bar  F12=Cancel  PA1=Susp

```

The Version field specifies the version of the CA PMA Chargeback application being used. Only the last four characters of the version field are available for entry. The default is the version specified using CA PMA Chargeback's Option function. All other fields are available for entry.

#### Access

The Budget Query Specifications panel appears when one of these events occur:

- You type QB in the fast path area of the Primary Panel's action bar.
- You select Budget on the Query pull-down.
- You return from one of the Budget Query Result panels.

```

-----
| Query | _____ |
| Pull-Down | |
|>Budget Query | v
-----
| Budget Query |
| Specifications |
| Panel |
-----
|
| ^
|
-----
| Budget Query |

```

```
| Result Panels |  
|>F3          |  
-----
```

**Input:**

The following Budget Query Specification panel fields are available for input. These input fields refer to the sample panel in Budget Query Specifications Panel.

Display Options

**Summarize** A one-character field that works with the Break option to determine the format of results. Valid entries for this field are N and Y. The default value is N and appears when you first select the panel.

When you set the Summarize option to Y, results display in summary form, or in summary-with-breaks form (see Budget Query Specifications Processing Options through Budget Query Specifications Processing Options).

**Break** A one-character field that works with the Summarize field, to determine result format. Valid entries for this field are N and Y. The default value is N and appears when you first select the panel.

When the Break option is Y, the Brk column is active (see C).

**Note:** At least one field in the Brk column must be set to Y, when you select the Break option. Otherwise, CA PMA Chargeback returns an error message.

CA PMA Chargeback ignores any values entered in the Brk column, if the Break option is not set to Y.

The Break field is valid **only** with the Summarize option.

Selection Criteria

**Note:** You can use the SQL wildcard character % alone or with any alphanumeric character string as selection criteria for these fields.

**Version** The last four characters of this field are available for data entry. Specify the version of CA PMA Chargeback you want to query.

**ORD Type** The three-character name of the output record identifier used for selection criteria. CA PMA Chargeback processes only those records with the ORD Type you specify.

**Charge Element** The name (up to 16 alphanumeric characters) of the Charge Element used for selection criteria. Only those records with Charge Element you specify display.

**Qualifier** The name (up to 16 alphanumeric characters) of the conditional test applied to the charge unit, used for selection criteria. CA PMA Chargeback selects only those records for which the qualifier applies.

**Period Number** The start of the range of accounting periods or the accounting period from which CA PMA Chargeback selects records.

**thru** The end of the range of accounting periods from which CA PMA Chargeback selects records.

The following entry fields indicate the accounting structures you want to query.

**Note:** CA PMA Chargeback displays only defined accounting structures. The examples presented in this chapter show an accounting structure with two levels. The accounting structures you define can be different.

Division Department Enter the name of a defined accounting level whose budget information you want to query.

**Action**

**F2=Exec**

Executes the query with the selections made.

## Budget Query Specifications Processing Options

Located on the second line of the Budget Query Specifications Panel are two processing options:

- Summarize
- Break

These options determine the type of output report that CA PMA Chargeback generates. The Summarize and Break fields work together to display results in three different types of formats:

- Summary
- Summary-with-breaks
- Detail
- **Summary Report (Summarize=Y, Break=N)**

When you set the Summarize option to Y and the Break option to N in the Budget Query Specifications panel, CA PMA Chargeback returns result fields Budget Amt and Count directly on the panel.

### Budget Amt

The total budget allocated for the records meeting query criteria.

### Count

The number of records meeting the query criteria.

To generate a summary report:

- Set the Summarize option to Y
- Set the Break option to N

```

+-- CBQBGTS -- Budget Query Specifications -----+
|   Panel  Exit  Help                               |
+-----+
| Type information for budget query. Then Execute.  |
| Summarize Y  Break N                               |
|                                                    |
| Version : PROD PROD                               |
|                                                    |
| Brk                                               |
| ORD Type . . . . .                               |
| Charge Element . .                               |
| Qualifier . . . . .                               |
| Period Number . . thru                           |
| DIVISION . . . . .                               |
| DEPARTMENT . . . . .                             |
|                                                    |
| F2=Exec                                           |
+-----+
    
```

After pressing F2 (Exec), fields Budget Amt and Count appear on the Budget Query Specifications panel. Note the following:

- The value within the Budget Amt field is the total budget for all records that meet the criteria specified in the Budget Query Specifications panel (see A. below).
- The count field displays the number of budgets meeting query specifications.
- Since there is no query criteria, a display of all records of the BUDTAB table result. In this example, the BUDTAB table contains 21 rows (see B. below).

```

USERID          CA PMA Chargeback          MM/DD/YY HH:MM:SS
_  Acctdefs  Cbdefs  Query  Data  Period  Options  Exit  Help

+-- CBQBGTS -- Budget Query Specifications -----+
|   Panel  Exit  Help                               |
|-----|
| Type information for budget query. Then Execute.  |
| Summarize Y  Break N                               |
|                                                    |
| Version : PROD PROD                               |
| Brk                                              |
| ORD Type . . . . . N Budget Amt :      2200.00000  A. |
| Charge Element . . . . . N Count . . :           21  B. |
| Qualifier . . . . . N                               |
| Period Number . . thru . . . . . N                 |
| DIVISION . . . . . N                               |
| DEPARTMENT . . . . . N                             |
|                                                    |
| F2=Exec                                           |
+-----+
Command ==>
F1=Help  F3=Exit  F4=Prompt  F9=Command  F10=Action Bar  F12=Cancel  PA1=Susp

```

#### ■ Summary-with-Breaks Report (Summarize=Y, Break=Y)

If you select both the Summarize and Break options, CA PMA Chargeback displays results in summary format on results panel (CBQBGTB). However, in contrast to a Summary report, result records are broken into **groups**. CA PMA Chargeback groups the records with identical values in the fields selected in the Brk column of the Budget Query Specifications panel.

Each row of panel CBQBGTB represents one **group of records** meeting the criteria specified in the Budget Query Specifications entry fields. The scroll bar denotes the number of groups available for viewing.

To generate a summary-with-breaks report with results grouped by ORD Type and Charge Element:

- Set the Summarize and Break options to Y
- Set the Brk fields for ORD Type and Charge Element to Y (see A. below)

```

+-- CBQBGS -- Budget Query Specifications -----+
| Panel Exit Help                               |
+-----+
| Type information for budget query. Then Execute. |
| Summarize Y Break Y                           |
| Version : PROD PROD                           |
|>|                                               |
| ORD Type . . . . . Brk A.                     |
| Charge Element . . Y                          |
| Qualifier . . . . . N                         |
| Period Number . . thru N                     |
| DIVISION . . . . . N                         |
| DEPARTMENT . . . . N                         |
+-----+
    
```

After pressing F2 (Exec), the following results panel appears. Note the following:

- CA PMA Chargeback summarizes and displays each unique combination of ORD Type and Charge Element separately. Two groups of records result (see A. below).
- The **Budget Amt** field is the total budget amount for the group of records meeting the criteria on the Budget Query Specifications panel (see B. below).
- The **Count** field holds the total number of records that make up the group shown (see C. below).

```

+-- CBQBGTB ----- Budget Query Results -----+
| Panel Exit Help                               |
+-----+
| More: + - 0001 Row: 1 of 2                   |
| A.                                             |
| Version . . . . : PROD PROD Budget Amt . : 1100.00000 B. |
| ORD Type . . . . : MBJ Count. . . . : 7 C. |
| Charge Element . : CPU-CHARGE |
| Qualifier . . . . : |
| Period Number . . : |
| DIVISION . . . . : |
| DEPARTMENT . . . . : |
| F7=Bkwd F8=Fwd |
+-----+
    
```

■ **Detail Report (Summarize=N, Break=N)**

If you do not select the Summarize and Break options, a **detail** report of the records within the BUDTAB appears on result panel (CBQBGTD). CA PMA Chargeback selects only those records that meet query criteria. It displays **all fields** for each selected record as a separate row. The scroll bar denotes the number of rows available for viewing.

The following is a sample detail report.

- CA PMA Chargeback displays all records of the BUDTAB table, since there is no query criteria (see A. on the next panel).

- The Budget Amt field specifies the budget for each record of the table meeting the query selection criteria (see B. on the next panel).
- The Description field describes each selected record (see C. on the next panel).

```

+-- CBQBGTD ----- Budget Query Results -----+
|      Panel  Exit  Help                               1. |
| -----|
|                                     More: + - 0001 Row: 1   of 0021 |
|                                     A. |
| Version . . . . : PROD PROD          Budget Amt . . :      600.00000 B. |
| ORD Type . . . . : MBJ                Description. . : BUDFORPER1      C. |
| Charge Element . : CPU-CHARGE                                     |
| Qualifier . . . . : SHIFT1                                           |
| Period Number . . : 1                                                 |
| DIVISION . . . . : RESTON                                             |
| DEPARTMENT . . . . : TECHWRIT                                         |
|

```

```

+-- CBQBGTD ----- Budget Query Results -----+
|      Panel  Exit  Help                               2. |
| -----|
|                                     More: + - 0001 Row: 2   of 0021 |
|                                     A. |
| Version . . . . : PROD PROD          Budget Amt . . :      500.00000 B. |
| ORD Type . . . . : MBJ                Description. . : BUDFORPER2      C. |
| Charge Element . : CPU-CHARGE                                     |
| Qualifier . . . . : SHIFT1                                           |
| Period Number . . : 2                                                 |

```

	DIVISION . . . . :	RESTON	
	DEPARTMENT . . . . :	TECHWRIT	
	F7=Bkwd	F8=Fwd	
+-----+-----+			

## Budget Query Specifications Entry Field Options

CA PMA Chargeback supports standard SQL queries. The format of the SQL query is:

**SELECT** fieldname **FROM** tablename **WHERE** (condition) {ORDER BY fields}

The following sections discuss how to use the various entry fields with processing options to generate SQL queries.

### **SELECT (fieldname).....**

You can select fields for viewing from the BUDTAB table in one of two ways:

- Detail report
- Summary-with-breaks report

If you select a detail report, the Summarize and Break option are **both** set to N. This displays all fields of the records from the BUDTAB table meeting any selection criteria.

If you select a summary-with-breaks report, the Summarize and Break options are **both** set to Y. CA PMA Chargeback groups results based on the fields you select in the Brk column. To select the fields you want results grouped by, enter Y in the appropriate row in the Brk column.

**Note:** Make sure the Break field is set to Y, otherwise CA PMA Chargeback ignores the values entered in the Brk column.

The Break option **cannot** be selected without also selecting the Summarize option.

### **from (tablename).....**

The Budget Query Specifications panel allows access to information contained in the BUDTAB. This is the default value and **cannot** be changed.

### **WHERE (condition).....**

If you wish to select only those records that meet specific criteria, you can add a conditional test next to any of the panel fields. This test can be a previously defined user name, or a number. The Period Number field accepts numeric values. All other entry fields accept **only** predefined user names.

**Note:** You can specify query criteria, regardless of the result format you select.

### Example 1: Specifying Selection Criteria within the ORD Type Field

The following panel shows how to generate a detail report of the records in the BUDTAB where ORD Type = MBJ.

- Set the Summarize and Break options to N.
- Enter MBJ in the area next to ORD Type (see A. below).

```
+-- CBQBGTS -- Budget Query Specifications -----+
|
| Panel Exit Help
|-----+
| Type information for budget query. Then Execute.
|
| Summarize N Break N      Version : PROD PROD
|
| >
|
| A.      Brk
| ORD Type . . . . . MBJ      N
| Charge Element . .      N
| Qualifier . . . . .      N
| Period Number . .      thru N
| DIVISION . . . . .      N
| DEPARTMENT . . . . .      N
|-----+

```

The panel below shows the results of specifying selection criteria within the ORD Type field. Note the following:

- The number of records that meet the criteria ORD Type = MBJ is 11 (see A. on the next panel).
- This panel shows the first of the records selected from the BUDTAB table.
- The application displays all fields for each record.

```
USERID          CA PMA Chargeback          MM/DD/YY HH:MM:SS
__ Acctdefs Cbdefs Query Data Period Options Exit Help
+-- CBQBGTD ----- Budget Query Results -----+
|
| Panel Exit Help
|-----+-----A-----|
|
| More: + - 0001 Row: 1 of 0011
|
| Version . . . . . : PROD PROD          Budget Amt . :          600.00000
| ORD Type . . . . . : MBJ              Description. : BUDFORPER1
| Charge Element . . : CPU-CHARGE
| Qualifier . . . . . : SHIFT1
| Period Number . . . : 1
| DIVISION . . . . . : RESTON
| DEPARTMENT . . . . . : TECHWRIT
|
| F7=Bkwd F8=Fwd
|-----+
|
| Command ==> _____
| F1=Help F3=Exit F4=Prompt F9=Command F10=Action Bar F12=Cancel PA1=Susp

```

## DB/CR Query Specifications Panel

The DB/CR Query Specifications panel allows you to query the contents of the DBCRTAB. Using the prompts provided, you can:

- Create an SQL query by simply filling a panel
- Execute and receive the results of the query

You specify query criteria and the manner in which you want results displayed. The following processing options, located on the DB/CR Query Specifications panel, determine result format.

- Summarize
- Break

These two options work together to display the following results. A complete discussion on these options with sample Results panels is in DB/CR Query Specifications Processing Options through DB/CR Query Specifications Processing Options.

Summarize	Break	Results
N	N	Detail report of the records that meet any criteria specified in the DB/CR Query Specifications panel. CA PMA Chargeback displays <b>each record</b> separately. For each record, CA PMA Chargeback provides values for the additional fields Debit Amt, Credit Amt, and Desc.
Y	N	Summary report of those records that meet any criteria specified in the DB/CR Query Specifications panel. Result fields Debit Amt, Credit Amt, and Count appear on the DB/CR Query Specifications panel. Fields Debit Amt, Credit Amt, and Count hold summary information.
Y	Y	Summary report of those records that meet any criteria specified in the DB/CR Query Specifications panel. Result records are broken into groups based on the Brk fields you select. CA PMA Chargeback displays <b>each group</b> separately. For each group of records, CA PMA Chargeback provides values for the additional fields Debit Amt, Credit Amt, and Count.

The following panel shows the DB/CR Query Specifications panel on entry of Debit/Credit Query. The values shown are the default ones.

```

USERID          CA PMA Chargeback          MM/DD/YY HH:MM:SS
__  Acctdefs  Cbdefs  Query  Data  Period  Options  Exit  Help

+-- CBQCRDS ----- DB/CR Query Specifications -----+
|  Panel  Exit  Help  |
+-----+
| Type information for debit/credit query. Then Execute. |
| A. Summarize N Break N          C. Version : PROD PROD |
|                               Brk          B.          |
| ORD Type . . . . .           N          |
| Charge Element . .           N          |
| Qualifier . . . . .           N          |
| Period Number . .           thru      N          |
| DIVISION . . . . .           N          |
| DEPARTMENT . . . . .         N          |
|
| F2=Exec
+-----+
Command ==>
F1=Help  F3=Exit  F4=Prompt  F9=Command  F10=Action Bar  F12=Cancel  PA1=Susp

```

The Version field specifies the version of the CA PMA Chargeback application being used. Only the last four characters of the Version field are available for entry. The default is the Version specified using CA PMA Chargeback's Option function. All other fields are available for entry.

#### Access

The DB/CR Query Specifications panel appears when one of these events occur:

- You type QD in the fast path area of the Primary Panel's action bar.
- You select Debit/Credit on the Query pull-down.
- You return from one of the DB/CR Query Result panels.

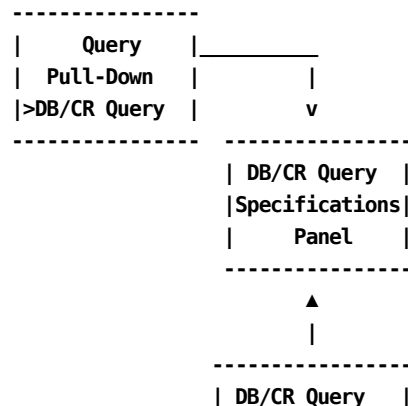

```
| Result Panels |  
|>F3          |  
-----
```

**Input:**

The following DB/CR Query Specification panel fields are available for input. These input fields refer to the sample panel on page DB/CR Query Specifications Panel.

**A.**

**Display Options**

Summarize A one-character field that works with the Break option, to determine the format of results. Valid entries for this field are N and Y. The default value is N and appears when you first select the panel.

When you set the Summarize option to Y, results display in summary form, or in summary-with-breaks form (see DB/CR Query Specifications Processing Options through DB/CR Query Specifications Processing Options).

Break A one-character field that works with the Summarize field to determine result format. Valid entries for this field are N and Y. The default value is N and appears when you first select the panel.

When the Break option is Y, the Brk column is active (see C).

**Note:** At least one field in the Brk column must be set to Y when you select the Break option. Otherwise, CA PMA Chargeback returns an error message.

CA PMA Chargeback ignores any values entered in the Brk column, if Break is N.

The Break field is valid only with the Summarize option.

**B.**

**Selection Criteria**

**Note:** You can use the SQL wildcard character % alone or with any alphanumeric character string as selection criteria for these fields.

Version The last four characters of this field are available for data entry. Specify the version of CA PMA Chargeback you want to query.

ORD Type The three-character name of the output record identifier used for selection criteria. CA PMA Chargeback processes only those records with the ORD Type you specify.

Charge Element The name (up to 16 alphanumeric characters) of the Charge Element used for selection criteria. Only those records with the Charge Element you specify display.

Qualifier The name (up to 16 alphanumeric characters) of the conditional test, applied to the charge unit, used for selection criteria. CA PMA Chargeback selects only those records for which the qualifier applies.

Period Number The start of the range of accounting periods or the accounting period from which CA PMA Chargeback selects records.

thru The end of the range of accounting periods from which CA PMA Chargeback selects records.

The following entry fields indicate the accounting structures you want to query.

**Note:** CA PMA Chargeback displays only defined accounting structures. The examples displayed in this chapter show an accounting structure with two levels. The accounting structures you define can be different.

Division Department Enter the name of a defined accounting level whose debit and credit information you want to query.

**Action**

**F2=Exec**

Executes the query with the selections you have made.

## DB/CR Query Specifications Processing Options

Located on the second line of the DB/CR Query Specifications Panel are two processing options:

- Summarize
- Break

These options determine the type of output report that CA PMA Chargeback generates. The Summarize and Break fields work together to display results in three different types of formats:

- Summary
- Summary-with-Breaks
- Detail
- **Summary Report (Summarize=Y, Break=N)**

When you set the Summarize option to Y and the Break option to N on the DB/CR Query Specifications panel, CA PMA Chargeback returns result fields Debit Amt, Credit Amt, and Count directly on the panel.

### Debit Amt

The total debit value for all records meeting query criteria.

### Credit Amt

The total credit value for all records meeting query criteria.

### Count

The number of records meeting the query criteria.

To generate a summary report on the panel below:

- Set the Summarize option to Y
- Set the Break option to N

```
+-- CBQCRDS ----- DB/CR Query Specifications -----+
|   Panel  Exit  Help
|-----+
| Type information for debit/credit query. Then Execute.
|
|> Summarize Y  Break N                               Version : PROD PROD
|
|   ORD Type . . . . .                               Brk
|   Charge Element . .                               N
|   Qualifier . . . . .                               N
|   Period Number . . thru                             N
|   DIVISION . . . . .                               N
|   DEPARTMENT . . . . .                             N
|
|   F2=Exec
|-----+
+-----+
```

After pressing F2 (Exec), fields Debit Amt, Credit Amt, and Count appear on the DB/CR Query Specifications panel. Note the following:

- The value within the Debit Amt and Credit Amt fields are total debit and credit amounts for those records which meet the criteria specified (see A. below).
- The Count field specifies the number of records meeting the criteria specified.
- Since there is no query criteria, all records of the DBCRTAB table result. In this example, the DBCRTAB table contains 21 rows (see B. below).

```

USERID          CA PMA Chargeback          MM/DD/YY HH:MM:SS
_  Acctdefs  Cbdefs  Query  Data  Period  Options  Exit  Help

+-- CBQCRDS ----- DB/CR Query Specifications -----+
|  Panel  Exit  Help                                     |
|-----|
| Type information for debit/credit query. Then Execute. |
| Summarize Y  Break N                                Version : PROD PROD |
|                                     Brk              |
| ORD Type . . . . .                               N              |
| Charge Element . . . . .                         N Debit Amt :    1500.000000 | A. |
| Qualifier . . . . .                               N Credit Amt:    750.000000 |   |
| Period Number . . . . . thru                       N Count . . :      21      | B. |
| DIVISION . . . . .                               N              |
| DEPARTMENT . . . . .                              N              |
|
| F2=Exec
|-----|
| Command ==>
| F1=Help  F3=Exit  F4=Prompt  F9=Command  F10=Action Bar  F12=Cancel  PA1=Susp

```

#### ■ Summary-with-Breaks Report (Summarize=Y, Break=Y)

If you select both the Summarize and Break options, CA PMA Chargeback displays results in summary format on results panel (CBQCRDB). However, in contrast to a Summary report, result records are broken into **groups**. CA PMA Chargeback groups the records with identical values in the fields selected in the Brk column of the DB/CR Query Specifications panel. It displays the result fields Debit Amt, Credit Amt, and Count for each group, separately.

Each row of panel CBQCRDB represents one **group of records** meeting the criteria specified in the DB/CR Query Specifications entry fields. The scroll bar denotes the number of groups available for viewing.

To generate a summary-with-breaks report and group results by ORD Type and Charge Element:

- Set the Summarize and Break options to Y
- Set the Brk fields for ORD Type and Charge Element to Y

```

+-- CBQCRDS ----- DB/CR Query Specifications -----+
| Panel Exit Help                                     |
+-----+
| Type information for debit/credit query. Then Execute. |
|
| > Summarize Y Break Y                               |
|                                                    |
|                                                    |
| ORD Type . . . . .                               |
| Charge Element . .                               |
| Qualifier . . . . .                               |
| Period Number . . thru                               |
| DIVISION . . . . .                               |
| DEPARTMENT . . . . .                               |
|                                                    |
| F2=Exec                                             |
+-----+
    
```

After pressing F2 (Exec), the following results panel appears. Note the following:

- CA PMA Chargeback summarizes and displays each unique combination of ORD Type and Charge Element separately. **Four** groups of records result (see A. below).
- Values within the Debit Amt and Credit Amt fields are total debit and credit values for the records in the group (see B. below).
- The Count field holds the number of records that make up the group (see C. below).

```

+-- CBQCRDB ----- Debit/Credit Query Results -----+
| Panel Exit Help                                     |
+-----+
|                                                    |
| More: + - 1 Row: 1 of 4                               |
|                                                    |
| Version . . . . . : PROD PROD                      |
| ORD Type . . . . . : MBJ                          |
| Charge Element . . : CPU-CHARGE                    |
| Qualifier . . . . . :                               |
| Period Number . . :                               |
| DIVISION . . . . . :                               |
| DEPARTMENT . . . . :                               |
| F7=Bkwd F8=Fwd                                       |
+-----+
    
```

■ **Detail Report (Summarize=N, Break=N)**

If you do not select the Summarize and Break options, a **detail** report of the fields within the DBCRTAB appears on panel (CBQCRDD). CA PMA Chargeback selects only those records which meet query criteria. It displays **all fields** of each selected record on a separate row. The scroll bar denotes the number of rows available for viewing.

In the sample detail report below, Note the following:

- CA PMA Chargeback displays all records of the DBCRTAB table, since there is no query criteria (see A. below).
- CA PMA Chargeback displays all fields of each record.

- The additional fields Debit Amt and Credit Amt hold debit and credit information for each record (see B. below).
- The Desc field describes the information in the record (see C. below).

```

USERID          CA PMA Chargeback          MM/DD/YY HH:MM:SS
__  Acctdefs  Cbdefs  Query  Data  Period  Options  Exit  Help
+-- CBQCRDD ----- Debit/Credit Query Results -----+
|   Panel  Exit  Help                                     |
|-----+-----+-----+-----+-----+-----+-----+
|                                     More: + - 1   Row: 1   of 0021
|                                     A.
| Version . . . . : PROD PROD          Debit Amt . :      250.00000
| ORD Type . . . . : MBJ              Credit Amt . :      150.00000
| Charge Element . : CPU-CHARGE       Desc . . . . : DB/CR for Per1   C.
| Qualifier . . . . : SHIFT1
| Period Number . . : 1
| DIVISION . . . . : RESTON
| DEPARTMENT . . . . : TECHWRIT
|
| F7=Bkwd  F8=Fwd
+-----+-----+-----+-----+-----+-----+-----+
Command ==> _____
F1=Help  F3=Exit  F4=Prompt  F9=Command  F10=Action Bar  F12=Cancel  PA1=Susp

```

## DB/CR Query Specifications Entry Field Options

CA PMA Chargeback supports standard SQL queries. The format of the SQL query is:

**SELECT** fieldname **FROM** tablename **WHERE** (condition) [ORDER BY fields]

The following sections discuss how to use the various entry fields with the processing options to generate SQL queries.

### **SELECT (fieldname).....**

You can select fields from the DBCRTAB table for viewing in one of two ways:

- Detail report
- Summary-with-breaks report

If you select a detail report, the Summarize and Break options are both set to N. CA PMA Chargeback displays all fields of the DBCRTAB table for those records which meet any selection criteria specified.

If you select a summary-with-breaks report, the Summarize and Break options are both set to Y. CA PMA Chargeback groups results based on the fields you select in the Brk column. To select the fields you want results grouped by, enter Y in the appropriate space in the Brk column. The default value is N.

**Note:** Make sure the Break field is set to Y, otherwise CA PMA Chargeback ignores the values entered in the Brk column.

The Break option **cannot** be selected without also selecting the Summarize option.

### **from (tablename).....**

The DB/CR Query Specifications panel allows access to information contained in the DBCRTAB. This is the default value and **cannot** be changed.

### **WHERE (condition).....**

If you wish to select only those records which meet specific criteria, you can add a conditional test next to any of the panel fields. This test can be a previously defined user name, or a number. The Period Number field accepts numeric values. All other entry fields accept only predefined user names.

**Note:** You can specify query criteria, regardless of the result format you select.

### Example 1: Specifying Selection Criteria within the Charge element field

To generate a query with selection criteria and display results in a detail report:

- Set the Summarize and Break options to N (see A. below)
- Enter the selection criteria CPU-CHARGE in the area next to Charge Element (see B. below)

```
+-- CBQCRDS ---DB/CR Query Specifications-----+
|   Panel  Exit  Help
|-----+
| Type information for debit/credit query.  Then execute.
|
| Summarize N  Break N      Version : PROD PROD
|           A.                Brk
| ORD Type . . . . .      N
| Charge Element . . CPU-CHARGE  B.  N
| Qualifier . . . . .      N
| Period Number . . . thru      N
| DIVISION . . . . .      N
| DEPARTMENT . . . . .      N
+-----+
```

The panel below shows the results of specifying selection criteria within the Charge Element field. Note the following:

- The number of records which meet the criteria is 5 (see A. below). This panel shows the first of the records selected from the DBCRTAB table.
- CA PMA Chargeback selects only those records with Charge Element = CPU-CHARGE (see B. below).

```
USERID          CA PMA Chargeback          MM/DD/YY HH:MM:SS
___ Acctdefs  Cbdefs  Query  Data  Period  Options  Exit  Help
+-- CBQCRDD ----- Debit/Credit Query Results -----+
|   Panel  Exit  Help
|-----+
|                                     A.-----
|                                     More: + - 1   Row: 1   of 5
|
| Version . . . . . : PROD PROD          Debit Amt . . :      250.00000
| ORD Type . . . . . : MBJ                Credit Amt . . :      150.00000
| Charge Element . . : CPU-CHARGE  B.     Desc . . . . . : DB/CR for Per1
| Qualifier . . . . . : SHIFT1
| Period Number . . . : 1
| DIVISION . . . . . : RESTON
| DEPARTMENT . . . . . : TECHWRIT
|
| F7=Bkwd  F8=Fwd
+-----+
Command ==> _____
F1=Help  F3=Exit  F4=Prompt  F9=Command  F10=Action Bar  F12=Cancel  PA1=Susp
```



# Chapter 7: Performing Data Functions

You invoke Data functions by selecting **Data** from the CA PMA Chargeback Primary Panel's action bar. The following Data Entry pull-down appears. You perform further selections by placing your cursor next to the function you want to perform and pressing Enter.

USERID	CA PMA Chargeback				MM/DD/YY HH:MM:SS			
—	Acctdefs	Cbdefs	Query	Data	Period	Options	Exit	Help
			1. Budgets					
			2. Debits/Credits					
			F12=Cancel					
Command ==> _____								
F1=Help F3=Exit F4=Prompt F9=Command F10=Action Bar F12=Cancel PA1=Susp								

On the next page is a description of these choices.

## **Budgets**

Assigns budgets to your accounting structures. Budgets can be assigned at multiple levels.

## **Debits/Credits**

Manually adjusts charges at any level of detail.

**Note:** You indicate your selection by entering a number in the entry field or by using the Enter key:

**1**

Takes you to the Budgets Entry panel shown in Budget Entry Panel.

**2**

Takes you to the Debit/Credit Primary panel shown in Debits/Credits Primary Panel.

**Enter**

Takes you to the function where the cursor is placed.

## Budgets Panels

Budgets are entered based on the organizational hierarchy defined by your CA PMA Chargeback Administrator using the Acctdefs function described in Chapter 3.

Budgets can be set up at any organizational level and further defined down to the:

- Charge element level
- Qualifier level

for one or more accounting periods.

Budgets also enable you to compare **actual** charges versus budget categories.

The following panels make up the Budgets panel set:

- Budgets Primary panel
- Budget Browse Criteria panel
- Budget List panel
- Expanded Budget List panel
- Budget Entry panel



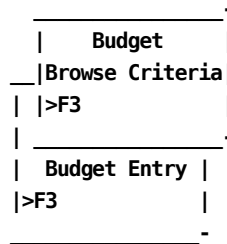

Type a 1 or 2 in the entry area and then press Enter.

**1.**

Takes you to the Budgets Entry panel.

**2.**

Takes you to the Budget Browse Criteria panel.

**F2**

**(Data Entry)** Takes you to the Budgets Entry panel (section Budget Entry Panel).

**F11**

**(Browse)** Takes you to the Budget Browse Criteria panel (in Budget Browse Criteria Panel).

## Budget Browse Criteria Panel

You use this panel to specify the Budget entries you want to view or update.

- You can leave all entry fields blank and press F2 (Execute) to view all currently defined budget entries.
- Only **defined** accounting structure names are displayed on the panel

The panel below shows that two accounting structures have been defined by the CA PMA Chargeback Administrator: Division and Department.

```

USERID              CA PMA Chargeback          MM/DD/YY HH:MM:SS
  Acctdefs  Cbdefs  Query  Data  Period  Options  Exit  Help
+--- CBDBGTB -- Budget Browse Criteria -----+
| Panel  Exit  Help                               |
|-----|
| Type browse criteria. Then Execute.             |
| Version . . . . . : PROD PROD                  |
| Period Number . . ___ thru ___                 |
| ORD Type . . . . . ___                         |
| Charge Element . . _____                 |
| Qualifier . . . . . _____                 |
| DIVISION . . . . . _____                 |
| DEPARTMENT . . . . . _____                 |
|
| F2=Exec                                         |
+-----+
Command ==> _____
F1=Help  F3=Exit  F4=Prompt  F9=Command  F10=Action Bar  F12=Cancel  PA1=Susp

```

On the next page is a description of the Budget Browse Criteria panel.

The Budget Browse Criteria panel appears when one of these events occurs:

- You press **F11** (Browse) on the Budgets Primary panel shown in Budgets Primary Panel.
- You return from the Budget List panel shown in Budget List Panel.

Budgets	_____
Primary	
>F11	v
	-----
	Budget Browse
	Criteria
	Panel

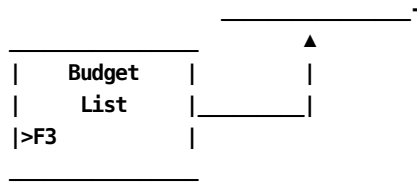

The following Budget Browse Criteria panel fields are available for input:

**Period Number**

Two, three-character numeric fields used to enter the range for which you want to view or update budgets. Use the first entry field to enter the start (from) of the range and the second entry field for the end of the range (to). Entering data in these fields in the following manner provide you with the following results:

From	thru	To	Result
___		___	List of all budget entries that meet the rest of the criteria specified
001		006	List of all budget entries in periods 001 thru 006 that meet the criteria specified
001		___	List of all budget entries in period 001 that meet the criteria specified
___		006	Invalid; you will get an error message

**ORD Type**

The three-character name of the output record identifier for which you want to define a budget category.

**Charge Element**

The name of the charge element (up to 16 alphanumeric characters) associated with the ORD type used to define the budget category.

**Qualifier**

The name of a conditional test specifically associated with the Charge Element. Examples of qualifier names are: @SYSTEM, @SHIFT, and so forth.

**Note:** Only defined accounting structures appear. Furthermore, these entry fields only accept the number of characters used to define the structure length on the Accounting Structure panel (Section Accounting Structure Panel). If you enter an incorrect number of characters, an informational message appears when you press F2=Exec.

Use the following entry field to indicate the accounting levels you want the budget applied to.

This example uses the following accounting structures:

**Division**

Enter the name of a defined subaccounting structure whose Budget you want to Browse or Update.

**Department**

Enter the name of a defined subaccounting structure whose Budget you want to Browse or Update.

F2 (Execute) executes the search and displays the Budget List panel (shown in Budget List Panel) that contains a list of budget entries meeting the search criteria.

## Example 1: Specifying Budget Browse Criteria by ORD Type & Period

The following panel shows how to specify Budget Browse Criteria by ORD Type and period. In this example, we are requesting a browse list of all budgets in periods 3 through 6 for ORD Type: MBJ.

```

USERID                               CA PMA Chargeback           MM/DD/YY HH:MM:SS
--  Acctdefs  Cbdefs  Query  Data  Period  Options  Exit  Help
+-- CBDBGTB -- Budget Browse Criteria -----+
|   Panel  Exit  Help  |
|-----|
| Type browse criteria. Then Execute. |
| Version . . . . . : PROD PROD |
| Period Number . . 003 thru 006 |
| ORD Type . . . . . MBJ |
| Charge Element . . _____ |
| Qualifier . . . . _____ |
| DIVISION . . . . _____ |
| DEPARTMENT . . . . _____ |
|                                     |
|                                     |
| F2=Exec |
+-----+
Command ==>
F1=Help  F3=Exit  F4=Prompt  F9=Command  F10=Action Bar  F12=Cancel  PA1=Susp
    
```

After you press F2 (Execute), you are presented with a Budget Browse List containing all records meeting your specifications. Section Example 1: Selecting a Browse List Entry By ORD Type for a Specific Period, shows the Browse List.



## Budget List Panel

The Budget List panel provides you with a list of all currently defined Budgets meeting the search criteria specified on the Budget Browse Criteria panel. The search criteria are redisplayed as protected display fields at the top of the panel.

**Note:** As you can see on the sample panel below, providing a meaningful description on the Budget Entry panel takes the guess work out of entry selection.

```

USERID          CA PMA Chargeback      MM/DD/YY HH:MM:SS
  Acctdefs  Cbdefs  Query  Data  Period  Options  Exit  Help
+-- CBDBGTL ----- -- Budget List -----+
|
| Panel  Exit  Help
|-----+
|
| Select a budget entry. Then select an action.
|
| Version . . . : PROD PROD      DIVISION . . . :
| Period Number :      thru      DEPARTMENT . . . :
| ORD Type . . . :
| Charge Element :
| Qualifier . . . :
|
|          Amount  Description  More: - + ____  Row 0001 of 0018
|
| -          10.00000
| -          10.00000  RESTON05
| -          10.00000  MBJPER5
|
| Enter  F7=Bkwd  F8=Fwd  F11=Expand
+-----+
|
| Command ==>
| F1=Help  F3=Exit  F4=Prompt  F9=Command  F10=Action Bar  F12=Cancel  PA1=Susp

```

### Access

The Budget List panel appears when one of these events occurs:

- When **F2** (Execute) is pressed on the Budget Browse Criteria panel shown in Budget Browse Criteria Panel.
- You return from the Expanded Budget List panel.

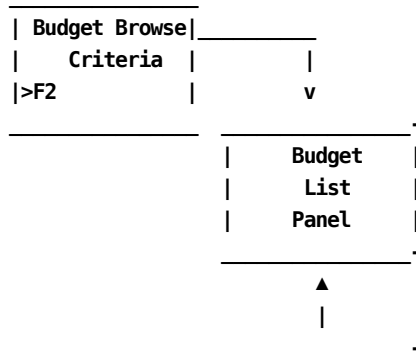



## Example 1: Selecting a Browse List Entry By ORD Type for a Specific Period

In Example 1: Specifying Budget Browse Criteria using ORD Type and Period in Example 1: Specifying Budget Browse Criteria by ORD Type & Period, we specified that we wanted to see a Budget list for:

- All MBJ ORDs
- For periods 3 through 6
- For all Division and Department substructures

```

+-- CDBGTB -- Budget Browse Criteria -----+
| Panel Exit Help
|-----|
| Type browse criteria. Then Execute.
|
| Version . . . . : PROD PROD
|
| Period Number . . 003 thru 006
| ORD Type . . . . : MBJ
| Charge Element . . _____
| Qualifier . . . . _____
| DIVISION . . . . _____
| DEPARTMENT . . . . _____
+-----+
    
```

After pressing F2 (Execute), the following Budget List panel appears.

```

USERID          CA PMA Chargeback          MM/DD/YY HH:MM:SS
__ Acctdefs Cbdefs Query Data Period Options Exit Help
+-- CDBGTL ----- Budget List -----+
| Panel Exit Help
|-----|
| Select a budget entry. Then select an action.
|
| Version . . . : PROD PROD          DIVISION . . . . :
| Period Number : 3 thru 6          DEPARTMENT . . . . :
| ORD Type . . . : MBJ
| Charge Element :
| Qualifier . . . :
|
|          Amount Description More: - + ____ Row 0001 of 0007
|
| -          10.00000 MBJ-003
| -          10.00000 MBJ-004
| -          10.00000 MBJ-005
|
| Enter F7=Bkwd F8=Fwd F11=Expand
+-----+
|
| Command ==>
| F1=Help F3=Exit F4=Prompt F9=Command F10=Action Bar F12=Cancel PA1=Susp
    
```

## Example 2: Selecting a Browse List Entry By Qualifier

In Example 2: Specifying Budget Browse Criteria by Qualifier in Example 2: Specifying Budget Browse Criteria by Qualifier, we specified that we wanted to see a Budget list for all entries whose charge elements use the qualifier @SHIFT1.

```

+-- CBDBGTB -- Budget Browse Criteria -----+
| Panel Exit Help |
|-----|
| Type browse criteria. Then Execute. |
| Version . . . . : PROD PROD |
| Period Number . . ___ thru ___ |
| ORD Type . . . . . ___ |
| Charge Element . . _____ |
| Qualifier . . . . @SHIFT_____ |
| DIVISION . . . . _____ |
| DEPARTMENT . . . . _____ |
+-----+

```

After pressing F2 (Execute), the following Budget List panel appears.

```

USERID          CA PMA Chargeback          MM/DD/YY HH:MM:SS
___ Acctdefs Cbdefs Query Data Period Options Exit Help
+-- CBDBGTL ----- Budget List -----+
| Panel Exit Help |
|-----|
| Select a budget entry. Then select an action. |
| Version . . . : PROD PROD          DIVISION . . . . : |
| Period Number : thru          DEPARTMENT . . . . : |
| ORD Type . . . : |
| Charge Element : |
| Qualifier . . . : @SHIFT1 |
| |
| Amount Description More: - + ___ Row 0001 of 0018 |
| - 10.00000 MBJ-001 |
| - 10.00000 MBJ-003 |
| - 10.00000 MBJ-005 |
| |
| Enter F7=Bkwd F8=Fwd F11=Expand |
+-----+
Command ==> _____
F1=Help F3=Exit F4=Prompt F9=Command F10=Action Bar F12=Cancel PA1=Susp

```

## Budget Entry Panel

Use this panel to create, view, or update budgets for the defined accounting structures and substructures in your organization. The Budget key is composed of:

- Version
- ORD Type
- Period Number
- Description
- Accounting level

If you come to this panel via a List panel, the Mode display field indicates you are in **UPD** (update) mode. This means that you can type over any information you want to change, or add new data. F6 (Delete) is only valid when you are in UPD mode.

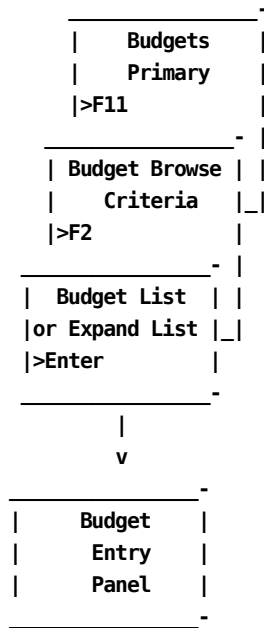

If you come to this panel via F2 (Data Entry) from the Budget primary panel, the Mode display field indicates you are in **INS** (insert) mode. You can do mass entries in this mode. Simply create your first entry, press F5 (Save), wait until the informational message tells you the entry is *inserted*, type over any fields that need to be changed for your next entry, and press F5. Continue in this manner until you have completed all your entries. **Remember**, F6 (Delete) is not valid when you are in INS mode. Therefore, if you make a mistake and the entry is inserted, you must perform the following steps to delete the entry:

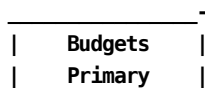



**Access**

The Budget Entry panel appears when one of these events occurs:

- When **F2** (Data Entry) is pressed on the Budgets Primary panel shown in Budgets Primary Panel.
- You make a selection on the Budget List (section Budget List Panel) or Expanded List panel (section Expanded Budget List Panel).

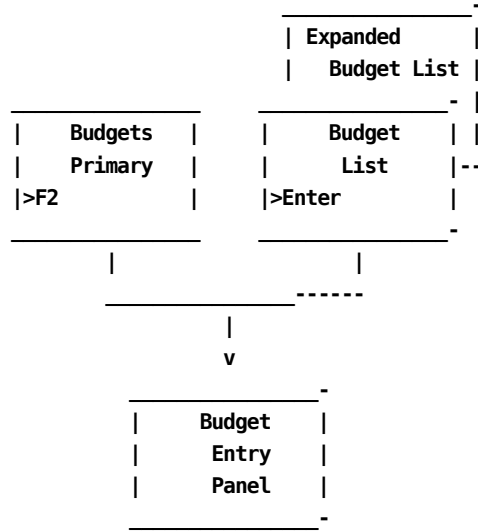

The following Budget Entry panel fields are available for input:

**ORD Type**

A three-character name of the output record identifier for which you want to define a budget category.

**Period Number**

A three-character numeric field defining the period number to which a budget amount is applied.

**Charge Element**

The name of the charge element (up to 16 alphanumeric characters) you want associated with the ORD type to further define the budget category.

**Budget Amount**

Enter the amount you are allocating as the budget for the line item that is defined by ORD type, Charge Element and Qualifier for the accounting structures you name below.

**Qualifier**

The name of a conditional test specifically associated with the Charge Element, or a global test you want applied. Examples of qualifier names are: @SYSTEM, @SHIFT, and so forth.

**Description**

A 20-character alphanumeric field used to provide a meaningful description of the budget item. This field appears on the List and Expanded List panels to make item selection easier.

**Note:** Only defined accounting structures are displayed. Furthermore, these entry fields only accept the number of characters used to define the structure length on the Accounting Structure panel (section Accounting Structure Panel). If you enter an incorrect number of characters, an informational message appears when you execute the save (F5=Save).

This example uses the following accounting structures:

**Division**

Enter the name of a defined accounting level whose budget you want to Browse or Update.

**Department**

Enter the name of a defined accounting level whose budgets you want to Browse or Update.

Depending upon **mode**, F5=Save lets you add (INS) or update (UPD) records to the table. F6=Delete (update mode only) lets you delete a record from the table.

### Example 1: Defining a Budget by ORD Type for an Accounting Level

The following panel shows you how to create a budget for a specific ORD type: MBJ for the East Coast Division. We want to define this budget for six period, the first period having a budget of \$20,000.

```

USERID          CA PMA Chargeback          MM/DD/YY HH:MM:SS
__  Acctdefs   Cbdefs   Query  Data  Period  Options  Exit  Help
+-- CBDBGTE _____ -- Budget Entry _____ +-----+
|  Panel  Exit  Help                                     |
|-----|
| Type information. Then select an action.                |
| Version . . . : PROD PROD          Mode . . . . : INS  |
| ORD Type . . . : MBJ                Period Number . 001 |
| Charge Element . _____          Budget Amount .   20000.00 |
| Qualifier . . . _____          Description . . MBJ-001_____ |
| DIVISION . . . : EAST COAST_____ |
| DEPARTMENT . . . _____         |
|                                     |
| F5=Save  F6=Delete                    |
+-----+
Command ==> _____
F1=Help  F3=Exit  F4=Prompt  F9=Command  F10=Action Bar  F12=Cancel  PA1=Susp
    
```

After completing the entry:

- Press F5 (Save)
- Wait until the informational message tells you the record is inserted
- Change the Period Number to 2
- If required, revise the Budget Amount
- Revise the Description to MBJ-002
- Press F5 (Save)

You continue in this manner: entering and saving data, until you have entered your budget figures for all six periods. If you have no further entries to create, exit out using F3 (Exit).

## Example 2: Defining a Budget for an Accounting Level

The following panel shows you how to create a budget for the East Coast Division. We want to define this budget for six periods: 1 - 6, with each period's budget as \$20,000.

```

USERID          CA PMA Chargeback          MM/DD/YY HH:MM:SS
  Acctdefs  Cbdefs  Query  Data  Period  Options  Exit  Help
+-- CBDBGTE ----- -- Budget Entry -----+
| Panel  Exit  Help |
|-----|
| Type information. Then select an action. |
|-----|
| Version . . . : PROD PROD          Mode . . . . : INS |
| ORD Type . . . . ____          Period Number . 001 |
| Charge Element . ____          Budget Amount .   20000.00 |
| Qualifier . . . . ____          Description . . EAST-COAST-001 |
| DIVISION . . . . EAST COAST____ |
| DEPARTMENT . . . . ____ |
|-----|
| F5=Save  F6=Delete |
+-----+

Command ==> _____
F1=Help  F3=Exit  F4=Prompt  F9=Command  F10=Action Bar  F12=Cancel  PA1=Susp

```

After completing the entry:

- Press F5 (Save)
- Wait until the informational message tells you the record is inserted
- Change the Period Number to 2
- Revise the Description to EAST-COAST-002
- Press F5 (Save)

You continue in this manner: entering and saving data, until you have entered your budget figures for all six periods. If you have no further entries to create, exit out using F3 (Exit).

### Example 3: Updating a Budget

The following example shows you how to update a budget amount for the EAST-COAST Division for Period 1. To update an existing Budget entry you must:

- Use the Budget Browse Criteria panel (shown on the next page) to specify the Budget entries for which you want a listing
- The Budget List panel appears. Position the cursor next to the entry you want to update and press Enter
- The Budget Entry panel for the selected entry appears
  - Mode is UPD (update)
  - Make your correction to the Budget Amount field
- Press F5 (Save)
- Press F3 (Exit) to continue with the next function you wish to perform

```
-----  
| Budgets |  
| Primary |  
|>F11 |  
-----  
| Budget Browse |  
| Criteria |  
|>F2 |  
-----  
| Budget List |  
| or Expand List |  
|>Enter |  
-----  
|  
| v  
-----  
| Budget |  
| Entry |  
| Panel |  
-----
```

While in UPD mode, it is not recommended that you change any **Budget key(s)**:

- Version
- ORD Type
- Period Number
- Accounting level

If you do so, the updated record overwrites the original and you lose your audit trail.

Following the path outlined on page Example 3: Updating a Budget at the Budgets primary panel, indicate you want to perform a Browse by pressing F11. Next, fill in the Budget Browse Criteria panel as shown below.

```

+- CBDBGT --- Budget Browse Criteria -----+
|   Panel  Exit  Help  |
|-----|
| Type browse criteria. Then Execute. |
|   Version . . . . : PROD PROD |
|   Period Number . . 001 thru 001 |
|   ORD Type . . . . : ____ |
|   Charge Element . . _____ |
|   Qualifier . . . . : _____ |
|   DIVISION . . . . : EAST-COAST____ |
|   DEPARTMENT . . . . : _____ |
+-----+

```

After pressing F2 (Execute), the following Budget List panel appears. Place the cursor next to the first entry and press Enter.

```

USERID      CA PMA Chargeback      MM/DD/YY HH:MM:SS
__ Acctdefs Cbdefs  Query Data Period  Options  Exit  Help
+- CBDBGTL ----- Budget List -----+
|   Panel  Exit  Help  |
|-----|
| Select a budget entry. Then select an action. |
|   Version . . . . : PROD PROD      DIVISION . . . . : EAST-COAST |
|   Period Number : 001 thru 001    DEPARTMENT . . . . : |
|   ORD Type . . . . : |
|   Charge Element : |
|   Qualifier . . . . : |
|   Amount  Description  More: - + ____  Row 0001 of 0002 |
|   -          20000.00  MBJ-001 |
|   -          20000.00  EAST-COAST-001 |
|   - |
|   Enter  F7=Bkwd  F8=Fwd  F11=Expand |
+-----+
Command ==> _____
F1=Help  F3=Exit  F4=Prompt  F9=Command  F10=Action Bar  F12=Cancel  PA1=Susp

```

The Budget Entry panel appears and indicates you are in UPD mode. You can now make the required changes as shown on the following panel.

On the panel below, we have changed the Budget Amount from 20000 to 15000.

```

USERID          CA PMA Chargeback          MM/DD/YY HH:MM:SS
__ Acctdefs  Cbdefs  Query  Data  Period  Options  Exit  Help
+-- CBDBGTE _____ -- Budget Entry _____ +-----+
   Panel  Exit  Help
+-----+
| Type information. Then select an action.
|
| Version . . . . : PROD PROD          Mode . . . . . : UPD
|                                     &TRIANGLE.
| ORD Type . . . . : _____        Period Number . 001
| Charge Element . : _____        Budget Amount . 15000.00
| Qualifier . . . . : _____        Description . . MBJ-001
| DIVISION . . . . : EAST COAST_____
| DEPARTMENT . . . : _____
|
|
| F5=Save  F6=Delete
+-----+

Command ==> _____
F1=Help  F3=Exit  F4=Prompt  F9=Command  F10=Action Bar  F12=Cancel  PA1=Susp
    
```

Once you have completed the update, press F5 (Save). You exit out by pressing F3 (Exit). As you exit out, you can view the result of your update on the Budget List panel.

```

+-- CBDBGTL _____ -- Budget List _____ +-----+
   Panel  Exit  Help
+-----+
| Select a budget entry. Then select an action.
|
| Version . . . . : PROD PROD          DIVISION . . . . : EAST-COAST
| Period Number : 001 thru 001        DEPARTMENT . . . . :
| ORD Type . . . . :
| Charge Element :
| Qualifier . . . . :
|
| Amount  Description  More: - + ____ Row 0001 of 0001
|
| -      15000.00  MBJ-001
| -      20000.00  EAST-COAST-001
| -
|
| Enter  F7=Bkwd  F8=Fwd  F11=Expand
+-----+
    
```

## Example 4: Deleting a Budget Record

Assume that you have created a Budget entry while in INS (insert) mode, successfully *inserted* it into the table and then realized you made a mistake and must delete the record.

For example, you incorrectly entered a **Budget key** (one of the following fields)

- Version
- ORD Type
- Period Number
- Accounting level

and rather than doing an update that overwrites the original record and result in the loss of your audit trail; you want to delete the incorrect record and create a new one.

```

-
| Budgets |
| Primary |
|>F11    |
-
| Budget Browse |
| Criteria  |
|>F2      |
-
| Budget List |
| or Expand List |
|>Enter    |
-
|
| v
-
| Budget |
| Entry  |
| Panel  |
-

```

You must:

- Exit out to the Budgets primary panel using F3 (Exit).
- Press F11 (Browse) which takes you to the Budgets Browse Criteria panel.
- Enter your criteria and press F2 (Execute). This displays the Budget List panel.
- Select the entry you want to delete using the Enter key.
- When the Budget Entry panel appears for the selected entry, you are in UPD mode. Press F6 (Delete) to delete the record.

- An informational message appears telling you the record was deleted and the Mode changes to **EXIT**.
- Press **any** key to return to the Budget List panel where you can continue selecting other records to update or delete.

Following the path outlined in Example 4: Deleting a Budget Record at the Budgets primary panel, indicate you want to do a Browse by pressing F11. Next, fill in the Budget Browse Criteria panel as shown below.

```

+- CBDBGTB -- Budget Browse Criteria -----+
  Panel  Exit  Help
-----
Type browse criteria. Then Execute.

Version . . . . . : PROD PROD

Period Number . . 001 thru 001
ORD Type . . . . . : ____
Charge Element . . : _____
Qualifier . . . . . : _____
DIVISION . . . . . : EAST-COAST____
DEPARTMENT . . . . : _____
+-----+
  
```

After pressing F2 (Execute), the following Budget List panel appears.

```

USERID          CA PMA Chargeback          MM/DD/YY HH:MM:SS
__ Acctdefs  Cbdefs  Query  Data  Period  Options  Exit  Help
+- CBDBGTL ----- Budget List -----+
  Panel  Exit  Help
-----
Select a budget entry. Then select an action.

Version . . . . . : PROD PROD          DIVISION . . . . . : EAST-COAST
Period Number : 001 thru 001          DEPARTMENT . . . . :
ORD Type . . . . . :
Charge Element :
Qualifier . . . . . :

          Amount  Description  More: - + ____  Row 0001 of 0002
-          15000.00  MBJ-001
-          100.00   MBP-001
-

Enter  F7=Bkwd  F8=Fwd  F11=Expand
+-----+
Command ==>
F1=Help  F3=Exit  F4=Prompt  F9=Command  F10=Action Bar  F12=Cancel  PA1=Susp
  
```

Place the cursor next to the first entry and press Enter. The Budget Entry panel, shown next, appears and indicates you are in UPD (update) mode.

To delete the record shown next, simply press F6 (Delete).

```

USERID          CA PMA Chargeback          MM/DD/YY HH:MM:SS
  ___ Acctdefs  Cbdefs  Query Data Period  Options  Exit  Help
+- CBDBGTE ----- Budget Entry -----+
  Panel  Exit  Help
|-----|
| Type information. Then select an action. |
|-----|
| Version . . . : PROD PROD          Mode . . . . : UPD |
|-----|
| ORD Type . . . . ___              Period Number . 001 |
| Charge Element . _____      Budget Amount .   15000.00 |
| Qualifier . . . . _____      Description . . MBJ-001 |
| DIVISION . . . . EAST COAST_____ |
| DEPARTMENT . . . . _____      |
|-----|
| F5=Save  F6=Delete |
+-----+

Command ==> _____
F1=Help  F3=Exit  F4=Prompt  F9=Command  F10=Action Bar  F12=Cancel  PA1=Susp

```

**Note:** You will receive a message informing you the record is deleted. The Mode field indicates you are now in EXIT mode.

```

USERID          CA PMA Chargeback          MM/DD/YY HH:MM:SS
  ___ Acctdefs  Cbdefs  Query Data Period  Options  Exit  Help
+- CBDBGTE ----- Budget Entry -----+
  Panel  Exit  Help
|-----|
| Type information. Then select an action. |
|-----|
| Version . . . : PROD PROD          Mode . . . . : EXIT |
|                                           &TRIANGLE. |
|-----|

```

You exit out by pressing **any** key.

**Note:** As you exit out, you should verify that the entry has been deleted from the Budget List panel. That is, the total number of rows displayed on the scroll bar has been decreased by one (as shown below).

The following Budget List panel no longer displays the MBJ-001 entry which we deleted.

```

USERID          CA PMA Chargeback          MM/DD/YY HH:MM:SS
  Acctdefs  Cbdefs  Query Data Period  Options  Exit  Help
+-CBDBGTL----- Budget List -----+
  Panel  Exit  Help
-----+-----
Select a budget entry. Then select an action.
Version . . . : PROD PROD          DIVISION . . . : EAST-COAST
Period Number : 001 thru 001      DEPARTMENT . . . :
ORD Type . . . :
Charge Element :
Qualifier . . . :

                Amount  Description  More: - + ____  Row 0001 of 0001
-                100.00  MBP-001
-
-
Enter  F7=Bkwd  F8=Fwd  F11=Expand
-----+-----
Command ==>
F1=Help  F3=Exit  F4=Prompt  F9=Command  F10=Action Bar  F12=Cancel  PA1=Susp

```

## Debits/Credits Panels

The Debits/Credits selection gives you the ability to manually adjust charges to any level of detail, providing the period they pertain to has not been closed. That is, processed and applied to an invoice. If the selected period is closed, any browse performed does not reflect the closed entries. Closed entries can be viewed using the Query function.

## Debits/Credits Primary Panel

You use this panel to specify the Debit/Credit function you want to perform. You can:

- Enter credits or debits for your accounting structures
- Browse currently defined credits and debits

```

USERID          CA PMA Chargeback      MM/DD/YY HH:MM:SS
_  Acctdefs  Cbdefs  Query  Data  Period  Options  Exit  Help

+-- CBDCRDP ----- Debits/Credits -----+
|      Panel  Exit  Help                    |
|-----|
| Select a function. Then Enter. Or select an action. |
| Version . : PROD PROD                             |
| _ 1. Data Entry                                   |
|   2. Browse                                       |
| Enter  F2=Data Entry  F11=Browse                 |
+-----+

Command ==>
F1=Help  F3=Exit  F4=Prompt  F9=Command  F10=Action Bar  F12=Cancel  PA1=Susp

```

Next is a description of the Debits/Credits primary panel.

### Access

The Debits/Credits primary panel appears when one of these events occurs:

- You type DC in the fast path area of the Primary Panel's action bar.
- You choose Debits/Credits on the Data Entry pull-down.
- You return from the Debits/Credits Browse Criteria, or Entry panel.

```

-----
| Data Entry | _____
| Pull-down |           |
|>Debits/Credit|       v
-----
|Debits/Credits|
| Primary      |
| Panel        |
-----
  ▲
  |
-----

```

```
Browse Criteria |      DB/CR      |
                | Browse Criteria |
                | >F3          |
                | ----- |
                |      Entry      |
                | >F3          |
                | ----- |
```

### Pathways

#### Enter

Type a 1 or 2 in the entry area and then press Enter:

- 1 takes you to the Debits/Credits Entry panel.
- 2 takes you to the Debit/Credit Browse Criteria panel.

#### F2

**(Create)** Takes you to the Debit/Credit Entry panel (on page Accessing the Debit/Credit Entry Panel Via the Primary Panel).

#### F11

**(Browse)** Takes you to the DB/CR Browse Criteria panel (on page DB/CR Browse Criteria Panel).

### DB/CR Browse Criteria Panel

You use this panel to specify the Debit and Credit entries you want to view or update.

**Note:**

- You can leave all entry fields blank and press F2 (Execute) to view all currently defined debit and credit entries.
- Only **defined** accounting structure names appear on the panel (see 1. below).

The next panel shows that two accounting levels have been defined by the CA PMA Chargeback Administrator: Division and Department.

```

USERID                                CA PMA Chargeback                MM/DD/YY HH:MM:SS
__  Acctdefs  Cbdefs  Query  Data  Period  Options  Exit  Help

+-- CBDCRDB --- DB/CR Browse Criteria -----+
| Panel  Exit  Help                               |
|-----|
| Type browse criteria. Then Execute.            |
| Version . . . . : PROD PROD                    |
| Period Number . . ___ thru ___                |
| ORD Type . . . . . ___                        |
| Charge Element . . _____                |
| Qualifier . . . . _____                |
| DIVISION . . . . _____                1.   |
| DEPARTMENT . . . . _____                |
|
| F2=Exec                                        |
+-----+
Command ==>
F1=Help  F3=Exit  F4=Prompt  F9=Command  F10=Action Bar  F12=Cancel  PA1=Susp

```

Next is a description of the DB/CR Browse Criteria panel.

**Access**

The DB/CR Browse Criteria panel appears when one of these events occurs:

- You press **F11** on the Debits/Credits Primary panel shown in Debits/Credits Primary Panel.
- You return from the Debits/Credits List panel shown in Debit/Credit List Panel.

```

-----
|Debits/Credits|-----
|  Primary  |          |
|>F11      |          v
-----

```

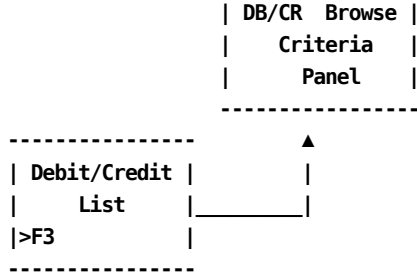

**Input**

The following DB/CR Browse Criteria panel fields are available for input:

**Period Number thru**

Two, three-character numeric fields used to enter the range for which you want to view or update Debits/Credits. Use the first entry field to enter the start of the range and the second entry field to define the end of the range. Entering data in these fields in the following manner provides you with the results listed below:

- Both entry fields blank: a list of all debit and credit entries meeting the rest of the criteria specified
- First entry field blank: a list of all debit and credit entries up to and including the ending period entered meeting the rest of the criteria specified
- Second entry field blank: a list of all debit and credit entries starting with the period specified

**ORD Type**

The three-character name of the output record identifier for which you want to define a debit or credit.

**Charge Element**

The name of the charge element (up to 16 alphanumeric characters) associated with the ORD type used to define the debit/credit category.

**Qualifier**

The name of a conditional test specifically associated with the Charge Element. Examples of qualifier names are: @SYSTEM, @SHIFT, and so forth.

The following entry fields are used to indicate the accounting levels you want the debits and credits applied to:

**Note:** Only defined accounting structures appear. Furthermore, these entry fields only accept the number of characters that was used to define the structure length on the Accounting Structure panel (section Accounting Structure Panel). If you enter an incorrect number of characters, an informational message appears when you press F2=Exec.

This example uses the following accounting structures:

**Division**

Enter the name of a defined accounting entity whose debits and credits you want to Browse or Update.

**Department**

Enter the name of a defined accounting entity whose debits and credits you want to Browse or Update.

**Actions****F2=Exec**

Executes the search for items meeting the criteria you specified and takes you to the Debit/Credit List panel (shown in Debit/Credit List Panel).

**Example 1: Specifying Debit/Credit Browse Criteria by ORD Type & Period**

The following panel shows how to specify Debit Credit Browse Criteria by ORD Type and period. In this example, we are requesting a browse list of all debits/credits in periods 3 through 6 for ORD Type: MBJ.

USERID	CA PMA Chargeback	MM/DD/YY HH:MM:SS
___ Acctdefs Cbdefs Query Data Period Options Exit Help		
+-- CBDCRDB --- DB/CR Browse Criteria -----+		
Panel Exit Help		
-----		
Type browse criteria. Then Execute.		
Version . . . . : PROD PROD		
Period Number . . 003 thru 006		
ORD Type . . . . . MBJ		
Charge Element . . _____		
Qualifier . . . . _____		
DIVISION . . . . _____		
DEPARTMENT . . . . _____		
F2=Exec		
+-----+		
Command ==>		
F1=Help F3=Exit F4=Prompt F9=Command F10=Action Bar F12=Cancel PA1=Susp		

After we press F2 (Execute), we are presented with a Debit/Credit Browse List containing all records meeting our specifications. Section Example 1: Selecting a Browse List Entry By ORD Type, shows the Browse List.

### Example 2: Specifying DB/CR Browse Criteria by Qualifier

The following panel shows how to specify Debit/Credit Browse Criteria by Qualifier. In this example, we are requesting a browse list of all budgets for all periods, levels, and ORD types whose Charge Elements are associated with the Qualifier: @SHIFT1.

```
USERID          CA PMA Chargeback      MM/DD/YY HH:MM:SS
  _  Acctdefs  Cbdefs  Query  Data  Period  Options  Exit  Help
+-- CBDCRDB --- DB/CR Browse Criteria -----+
| Panel  Exit  Help                               |
|-----|
| Type browse criteria. Then Execute.             |
| Version . . . . : PROD PROD                   |
| Period Number . . ___ thru ___                 |
| ORD Type . . . . : ___                         |
| Charge Element . . _____                 |
| Qualifier . . . . : @SHIFT1_____             |
| DIVISION . . . . : _____                 |
| DEPARTMENT . . . . : _____                 |
|
| F2=Exec                                         |
+-----+
Command ==>
F1=Help  F3=Exit  F4=Prompt  F9=Command  F10=Action Bar  F12=Cancel  PA1=Susp
```

After we press F2 (Execute), we are presented with a Debit/Credit Browse List containing all records meeting our specifications. Section Example 2: Selecting a Browse List Entry By Qualifier, shows the Browse List.

## Debit/Credit List Panel

The Debit/Credit List panel provides you with a list of all currently defined credits and debits meeting the search criteria specified on the DB/CR Browse Criteria panel. The search criteria are redisplayed as protected display fields at the top of the panel.

**Note:** As you can see on the next sample panel, providing a meaningful description on the Debit/Credit Entry panel takes the guess work out of entry selection. Also note that CA PMA Chargeback returns an indicator telling you whether the entry is a Debit or a Credit (see 1. below).

```

USERID          CA PMA Chargeback      MM/DD/YY HH:MM:SS
  ___  Acctdefs  Cbdefs  Query  Data  Period  Options  Exit  Help
+-- CBDCRDL ----- Debit/Credit List -----+
| Panel  Exit  Help |
|-----|
| Select a budget entry. Then select an action. |
| Version . . . : PROD PROD      DIVISION . . . : |
| Period Number :      thru      DEPARTMENT . . . : |
| ORD Type . . . : |
| Charge Element : |
| Qualifier . . . : |
|
|          Amount  Description  More: - + ____  Row 0001 of 0025 |
|          -      5.00000      CREDIT      1. |
|          -      5.00000      CREDIT |
|          -      5.00000      DEBIT |
|
| Enter  F7=Bkwd  F8=Fwd  F11=Expand |
+-----+
Command ==> _____
F1=Help  F3=Exit  F4=Prompt  F9=Command  F10=Action Bar  F12=Cancel  PA1=Susp

```

Next is a description of the Debit/Credit List panel.

### Access

The Debit/Credit List panel appears when one of these events occurs:

- When **F2** (Execute) is pressed on the DB/CR Browse Criteria panel shown on page DB/CR Browse Criteria Panel.
- You return from the Expanded List panel.

```

-----
| DB/CR Browse | _____ |
| Criteria     |         |
|>F2         |         v |
-----
| Debit/Credit |
| List         |
| Panel       |

```

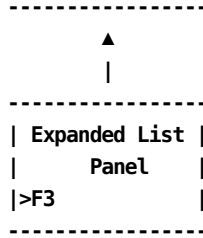

**Scrolling**

F7 and F8 let you scroll backward and forward through the Debit/Credit selection list. You can also use the scroll bar, as explained on page Sample List Panel, to move through the list.

**Pathways**

**Enter**

By placing the cursor next to the item you want to view and pressing **Enter**, you can go to the Debits/Credits Entry panel (shown on page Accessing the Debit/Credit Entry Panel Via the Primary Panel) to examine and optionally update its contents.

**F11**

**(Expand)** Gives you an eight-line display of the Debit/Credit List panel.

### Debit/Credit Expanded List Panel

The following panel appears when you press F11 (Expand) on the Debit/Credit List panel shown in Debit/Credit List Panel. The only difference between the two panels is the protected fields are not displayed. This allows you to view more information on a single panel. The Expanded List panel functions in the same way as the list panel from which it was called.

```
USERID          CA PMA Chargeback          MM/DD/YY HH:MM:SS
__ Acctdefs Cbdefs Query Data Period Options Exit Help
+-- CBDCRDX ----- Expanded Debit/Credit List -----+
| Panel Exit Help |
|-----|
| Select a budget entry. Then Enter. |
|                                     |
|          Amount Description      More: - + ____ Row 0009 of 0025 |
|-----|
|  -          50.00000 CRE50                CREDIT |
|  -          50.00000 CRE50                DEBIT |
|  -          50.00000 DEB50                DEBIT |
|  -          50.00000 DEB50X              DEBIT |
|  -          50.00000 N02                  DEBIT |
|  -          50.00000 TEST1-DEBIT         DEBIT |
|  -          60.00000 TEST2-CREDIT        CREDIT |
|  -          150.00000 DEBIT              CREDIT |
|                                     |
| Enter F7=Bkwd F8=Fwd |
|-----|
| Command ==> |
| F1=Help F3=Exit F4=Prompt F9=Command F10=Action Bar F12=Cancel PA1=Susp |
```

### Example 1: Selecting a Browse List Entry By ORD Type

In Example 1 in Example 1: Specifying Debit/Credit Browse Criteria by ORD Type & Period, we specified we wanted to see a Debit/Credit list for:

- All MBJ ORDs
- For periods 3 through 6
- For all Division and Department substructures

```

+-- CBDCRDB --- DB/CR Browse Criteria -----+
| Panel Exit Help |
|-----|
| Type browse criteria. Then Execute. |
| |
| Version . . . . : PROD PROD |
| |
| Period Number . . 003 thru 006 |
| ORD Type . . . . : MBJ |
| Charge Element . . _____ |
| Qualifier . . . . _____ |
| DIVISION . . . . _____ |
| DEPARTMENT . . . . _____ |
|-----+
  
```

After pressing F2 (Execute), the following Debit/Credit List panel appears.

```

USERID          CA PMA Chargeback          MM/DD/YY HH:MM:SS
__ Acctdefs  Cbdefs  Query  Data  Period  Options  Exit  Help
+-- CBDCRDL ----- Debit/Credit List -----+
| Panel Exit Help |
|-----|
| Select a budget entry. Then select an action. |
| |
| Version . . . . : PROD PROD          DIVISION . . . . : |
| Period Number : 003 thru 006        DEPARTMENT . . . . : |
| ORD Type . . . : MBJ |
| Charge Element : |
| Qualifier . . . : |
| |
|          Amount  Description  More: - + ____  Row 0001 of 0025 |
| -          5.00000 |          CREDIT |
| -          5.00000 |          CREDIT |
| -          5.00000 |          DEBIT |
| |
| Enter  F7=Bkwd  F8=Fwd  F11=Expand |
|-----+
Command ==>
F1=Help  F3=Exit  F4=Prompt  F9=Command  F10=Action Bar  F12=Cancel  PA1=Susp
  
```

## Example 2: Selecting a Browse List Entry By Qualifier

In Example 2: Specifying DB/CR Browse Criteria by Qualifier, we indicated we wanted to see a Debit/Credit list for all entries whose ORDs use the qualifier @SHIFT1.

```
+-- CBDCRDB --- DB/CR Browse Criteria -----+
| Panel Exit Help
|-----|
| Type browse criteria. Then Execute.
|
| Version . . . . : PROD PROD
|
| Period Number . . ___ thru ___
| ORD Type . . . . : ___
| Charge Element . . : _____
| Qualifier . . . . : @SHIFT1_____
| DIVISION . . . . : _____
| DEPARTMENT . . . . : _____
|-----|
```

After pressing F2 (Execute), the following Debit/Credit List panel appears.

```
USERID          CA PMA Chargeback          MM/DD/YY HH:MM:SS
___ Acctdefs Cbdefs Query Data Period Options Exit Help

+-- CBDCRDL ----- Debit/Credit List -----+
| Panel Exit Help
|-----|
| Select a budget entry. Then select an action.
|
| Version . . . . : PROD PROD          DIVISION . . . . :
| Period Number : thru          DEPARTMENT . . . . :
| ORD Type . . . . :
| Charge Element :
| Qualifier . . . : @SHIFT1
|
|          Amount Description More: - + ___ Row 0001 of 0025
|
| -          5.00000          CREDIT
| -          5.00000          CREDIT
| -          5.00000          DEBIT
|
| Enter F7=Bkwd F8=Fwd F11=Expand
|-----|
| Command ==> _____
| F1=Help F3=Exit F4=Prompt F9=Command F10=Action Bar F12=Cancel PA1=Susp
```

## Debits/Credits Entry Panel

You use this panel to create, view, or update Debits and Credits for the defined accounting structures and substructures in your organization. The Debit/Credit key is composed of:

- Version
- ORD Type
- Period Number
- Description
- Accounting level

### Accessing the Debit/Credit Entry Panel Via the List Panel

If you come to this panel via the Debit/Credit List panel, the Mode display field. Accessing the Debit/Credit Entry Panel Via the Primary Panel) indicates you are in **UPD** (update) mode. This means that you can type over any information you want to change, or add new data. F6 (Delete) is only valid when you are in UPD mode. Note that the Amount Field on the Accessing the Debit/Credit Entry Panel Via the Primary Panel) reflects whether the entry is a Debit or a Credit.

**Note:** We do not recommend changing any **Debit/Credit key(s)** while in UPD mode. If you do so, the updated record overwrites the original record.

```
-----  
| Debits/Credits |  
|   Primary   |  
|>F11        |  
-----  
| DB/CR Browse | |  
|   Criteria   | |  
|>F2         | |  
-----  
| Debit/Credit | |  
|   List      | |  
| or Expand List |  
|>Enter      | |  
-----  
|  
| v  
-----  
| Debit/Credit |  
|   Entry     |  
|   Panel     |  
-----
```

## Accessing the Debit/Credit Entry Panel Via the Primary Panel

If you come to this panel via F2 (Data Entry) from the Debits/Credits primary panel, the **Mode** display field (see A. on page Accessing the Debit/Credit Entry Panel Via the Primary Panel) indicates you are in **INS** (insert) mode. You can do mass entries in this mode. Note that the default display for **Amount** see B. on page Accessing the Debit/Credit Entry Panel Via the Primary Panel is **DEBIT**. To enter a credit, just type over the word DEBIT, making it CREDIT. Simply create your first entry, press F5 (Save), wait until the informational message tells you the entry is *inserted*, type over any fields that need to be changed for your next entry and press F5. **Remember, if you are mixing debit and credit definitions in one session, to check the Amount prompt.** Continue in this manner until you have completed all your entries. **Note:** F6 (Delete) is not valid when you are in INS (insert) mode. Therefore, if you make a mistake and the entry is inserted, you must perform the following steps to delete the entry:

```

-----
| Debit/Credits |
|   Primary    |
|>F2          |
-----
      |
      v
-----
| Debit/Credit |
|   Entry      |
|   Panel      |
-----

```

- Exit out to the Debits/Credits primary panel.
- Press F11 (Browse) which takes you to the DB/CR Browse Criteria panel.
- Enter your criteria and press F2 (Execute). This displays the Debit/Credit List panel.
- Select the entry you want to delete using the Enter key.
- When the Debit/Credit Entry panel appears for the selected entry you are in UPD mode. Press F6 (Delete) to delete the record.
- An informational message appears telling you the record is deleted and Mode changes to **EXIT**.
- Press **any** key to return to the Debit/Credit List panel where you can continue selecting other records to update or delete.

On the next page is a description of the Debit/Credit Entry panel.

```

USERID          CA PMA Chargeback          MM/DD/YY HH:MM:SS
__ Acctdefs  Cbdefs  Query  Data  Period  Options  Exit  Help

+-- CBDCRDE ----- Debit/Credit Entry -----+
| Panel  Exit  Help |
|-----|
| Type information and save. Or Delete. |
| Version . . . : PROD PROD  A.  Mode . . . . : UPD |
| ORD Type . . . : MBJ          Period Number . 001 |
| Charge Element . CPU-CHARGE    CREDIT Amount . B.    05.00 |
| Qualifier . . . :              Description . . CPU-CHARGE CREDIT |
| DIVISION . . . : AA_____ |
| DEPARTMENT . . . : _____ |
|-----|
| F5=Save  F6=Delete |
+-----+

Command ==>
F1=Help  F3=Exit  F4=Prompt  F9=Command  F10=Action Bar  F12=Cancel  PA1=Susp
    
```

The following is a description of the Debit/Credit Entry panel.

**Access**

The Debits/Credits Entry panel appears when one of these events occurs:

- When **F2** is pressed on the Debits/Credits primary panel.
- You make a selection on the Debit/Credit List or Expanded List panel.

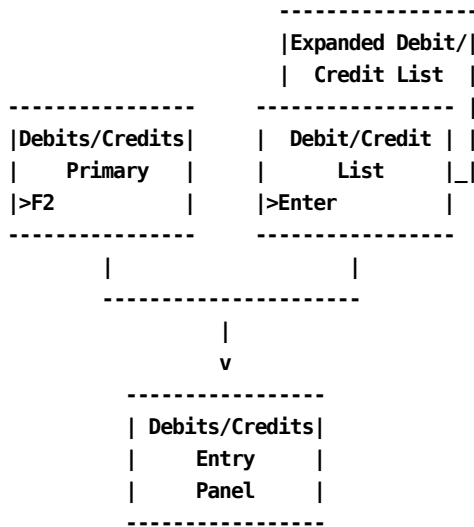

**Input:**

The Debit/Credits Entry panel contains the following input fields:

**ORD Type**

A three-character name of the output record identifier to which you want to apply a debit or credit.

**Period Number**

A three-character numeric field defining the period number for which the credit or debit amount is applicable.

**Charge Element**

The name of the charge element (up to 16 alphanumeric characters) you want to associate with the ORD type to further define the debit or credit category.

**Debit Amount or Credit Amount**

The default display is Debit when in INS (insert) mode. You can type over this field to change it to Credit.

**Qualifier**

The name of a conditional test specifically associated with the Charge Element, or a global test you want applied. Examples of qualifier names are: @SYSTEM, @SHIFT, and so forth.

**Description**

A 20-character alphanumeric field used to provide a meaningful description of the budget item. This field appears on the List and Expanded List panels to ease item selection.

The following entry fields are used to indicate the accounting levels to which you want debit/credits applied:

**Note:** Only defined accounting structures appear. Furthermore, these entry fields only accept the number of characters used to define the structure length on the Accounting Structure panel (see section Accounting Structure Panel). If you enter an incorrect number of characters, an informational message appears when you execute a save (F5=Save).

**Division**

Enter the name of a defined subaccounting structure whose debits/credits you want to Browse or Update.

**Department**

Enter the name of a defined subaccounting structure whose debit/credits you want to Browse or Update.

**Actions****F5=Save**

Depending upon **mode**, lets you add (INS) or update (UPD) records to the table.

**F6=Delete**

UPD (update) mode only: lets you delete a record from the table.

## Example 1: Creating a Credit

From the Debit/Credits primary panel, select F2 (Create). The Debit/Credit Entry panel appears.

The following panel shows you how to create a Credit for the East Coast Division.

We want to enter:

- A credit of \$5.00
- For ORD Type MBJ
- For CPU-CHARGE charge elements
- For periods 001 through 003
- With a record description of E-COAST-CPU-CRED-001
- For Division: East Coast

**Note:** Remember, when this panel first displays, the CREDIT/DEBIT Amount field displays as **DEBIT**, the default. Therefore, the first thing we should do is type over the field to make it read **CREDIT**.

```

USERID          CA PMA Chargeback          MM/DD/YY HH:MM:SS
__  Acctdefs   Cbdefs  Query  Data  Period  Options  Exit  Help

+-- CBDCRDE ----- Debit/Credit Entry -----+
| Panel  Exit  Help |
|-----|
| Type information and save. Or Delete. |
|-----|
| Version . . . : PROD PROD          Mode . . . . : INS |
| ORD Type . . . : MBJ              Period Number . 001 |
| Charge Element . CPU-CHARGE       credit Amount .   5.00 |
| Qualifier . . .                   Description . . E-COAST-CPU-CRED-001 |
| DIVISION . . . : EAST COAST_____ |
| DEPARTMENT . . . : _____ |
|-----|
| F5=Save  F6=Delete |
+-----+

Command ==>
F1=Help  F3=Exit  F4=Prompt  F9=Command  F10=Action Bar  F12=Cancel  PA1=Susp

```

After completing the entry:

- Press F5 (Save)
- Wait until the informational message tells you the record is inserted
- Change the Period Number to 002

- Revise the Description to E-COAST-CPU-CRED-002
- Press F5 (Save)

You continue in this manner: entering and saving data, until you have entered your amounts for all three periods. If you have no further entries to create, exit out using F3 (Exit).

## Example 2: Creating a Debit

From the Debit/Credits primary panel, select F2 (Create). The Debit/Credit Entry panel appears.

The following panel shows you how to create a Debit for the West Coast Division.

We want to enter:

- A Debit of \$10.00
- For ORD Type MBJ
- For CPU-CHARGE charge elements
- For period 006
- With a record description of W-COAST-CPU-DEB-006
- For Division: West Coast

**Note:** Remember, when this panel first displays, the CREDIT/DEBIT Amount field displays as **DEBIT**, the default. Therefore, you do **not** have to type over the field.

```

USERID          CA PMA Chargeback          MM/DD/YY HH:MM:SS
__  Acctdefs   Cbdefs   Query  Data  Period  Options  Exit  Help
+-- CBDCRDE ----- Debit/Credit Entry -----+
| Panel  Exit  Help                               |
|-----|
| Type information and save. Or Delete.           |
| Version . . . : PROD PROD          Mode . . . . : INS |
| ORD Type . . . : MBJ                Period Number . 006 |
| Charge Element . CPU-CHARGE          DEBIT Amount . 10.00 |
| Qualifier . . .                      Description . . W-COAST-CPU-DEB-006 |
| DIVISION . . . : WEST COAST_____ |
| DEPARTMENT . . . _____ |
|-----|
| F5=Save  F6=Delete |
+-----+
Command ==>
F1=Help  F3=Exit  F4=Prompt  F9=Command  F10=Action Bar  F12=Cancel  PA1=Susp

```

After completing the entry:

- Press F5 (Save)
- Wait until the informational message tells you the record is inserted

You can continue creating Debits and Credits until you have entered all amounts. Remember to check the Amount field to verify whether you are doing a debit or a credit. When you have no further entries to create, exit out using F3 (Exit).

### Example 3: Updating a Credit

The following example shows you how to update a credit amount for the EAST-COAST Division for Period 1.

- Use the DB/CR Browse Criteria panel to specify the Credit entries you for which you want a list
- The Debit/Credit List panel appears. Position the cursor next to the entry you want to update and press Enter
- When the Budget Entry panel for the selected entry appears:
  - Mode is UPD (update)
  - Amount field reads: Credit Amount
- Press F5 (Save)
- Press F3 (Exit) to continue with the next function you want to perform

**Note:** While in UPD mode, do **not** change any **Debit/Credit key(s)**

- Version
- ORD Type
- Period Number
- Description
- Accounting level

If you do so, the updated record overwrites the original.

```

-----
| Debits/Credits |
|   Primary     |
|>F11          |
-----
| DB/CR Browse |
|   Criteria   |
|>F2          |
-----
| Debit/Credit |
|or Expand List|
|>Enter       |
-----
|
| v
-----
| Debit/Credit |
|   Entry     |
|   Panel     |
-----

```

Following the path outlined in Example 3: Updating a Credit at the Debits/Credits primary panel, indicate you want to perform a Browse by pressing F11. Next, fill in the Budget Browse Criteria panel.

```
+-- CBDCRDB --- DB/CR Browse Criteria -----+
| Panel Exit Help
|-----|
| Type browse criteria. Then Execute.
|
| Version . . . . : PROD PROD
|
| Period Number . . 001 thru 001
| ORD Type . . . . : ____
| Charge Element . . : _____
| Qualifier . . . . : _____
| DIVISION . . . . : EAST COAST _____
| DEPARTMENT . . . . : _____
+-----+
```

After pressing F2 (Execute), the following Debit/Credit List panel appears. Place the cursor next to the first entry and press Enter.

```
USERID          CA PMA Chargeback          MM/DD/YY HH:MM:SS
__ Acctdefs  Cbdefs  Query  Data  Period  Options  Exit  Help

+-- CBDCRDL ----- Debit/Credit List -----+
| Panel Exit Help
|-----|
| Select a budget entry. Then select an action.
|
| Version . . . : PROD PROD          DIVISION . . . . : EAST COAST
| Period Number : 001 thru 001      DEPARTMENT . . . :
| ORD Type . . . :
| Charge Element :
| Qualifier . . . :
|
|          Amount  Description  More: - + ____  Row 0001 of 0005
|
| -          5.00000  E COAST-CPU-CRED-001  CREDIT
| -          5.00000  E COAST-DIO-CRED-001  CREDIT
| -          5.00000  E COAST                    DEBIT
|
| Enter  F7=Bkwd  F8=Fwd  F11=Expand
+-----+
Command ==>
F1=Help  F3=Exit  F4=Prompt  F9=Command  F10=Action Bar  F12=Cancel  PA1=Susp
```

The Debit/Credit Entry panel appears and indicates you are in UPD mode. You can then make the required changes as shown on the following panel.

On this panel the Credit Amount has been changed from 5.00 to 50.00.

```

USERID          CA PMA Chargeback          MM/DD/YY HH:MM:SS
__ Acctdefs  Cbdefs  Query  Data  Period  Options  Exit  Help

+-- CBDCRDE ----- Debit/Credit Entry -----+
| Panel  Exit  Help |
|-----|
| Type information and save. Or Delete. |
| Version . . . : PROD PROD          Mode . . . . : UPD |
|                                     &TRIANGLE. |
| ORD Type . . . . MBJ              Period Number . 001 |
| Charge Element . CPU-CHARGE       CREDIT Amount . 50.00 |
| Qualifier . . .                   Description . . E-COAST-CPU-CRED-001 |
| DIVISION . . . . EAST COAST_____ |
| DEPARTMENT . . . _____ |
|
| F5=Save  F6=Delete |
+-----+

Command ==>
F1=Help  F3=Exit  F4=Prompt  F9=Command  F10=Action Bar  F12=Cancel  PA1=Susp

```

Once you have completed the update, press F5 (Save). Exit out by pressing F3 (Exit). You will see the result of your update on the Debit/Credit List panel.

### Example 4: Updating a Debit (Changing a Debit to a Credit)

To update a debit, follow the same procedure used for updating a credit. However, in this example we are changing a **debit** EAST-COAST Division for Period 1 to a **credit**.

- You must use the DB/CR Browse Criteria panel to specify the Credit entries for which you want a listing
- The Debit/Credit List panel appears. Position the cursor next to the entry you want to update and press Enter
- When the Debit/Credit Entry panel for the selected entry appears:
  - Mode is UPD (update)
  - Amount field reads: Debit Amount
- Press F5 (Save)
- Press F3 (Exit) to continue with the next function you want to perform

**Note:** While in UPD mode, do **not** change any **Debit/Credit key(s)**

- Version
- ORD Type
- Period Number
- Description
- Accounting level

If you do so, the updated record overwrites the original.

```
-----  
| Debits/Credits |  
|   Primary     |  
|>F11          |  
-----  
| DB/CR Browse | |  
|   Criteria   |_|  
|>F2          |  
-----  
| Debit/Credit | |  
|or Expand List|_|  
|>Enter       |  
-----  
|  
| v  
-----  
| Debit/Credit |  
|   Entry     |  
|   Panel     |  
-----
```

**Caution** While this action is possible, from an accounting viewpoint it is **not** recommended.

Following the path outlined in Example 4: Updating a Debit (Changing a Debit to a Credit) at the Debits/Credits primary panel, indicate you want to perform a Browse by pressing F11. Next, fill in the DB/CR Browse Criteria panel as shown below.

```

+-- CBDCRDB --- DB/CR Browse Criteria -----+
|      Panel  Exit  Help                       |
+-----+
| Type browse criteria. Then Execute.         |
|                                              |
| Version . . . . : PROD PROD                 |
| Period Number . . 001 thru 001             |
| ORD Type . . . . : ____                     |
| Charge Element . . _____              |
| Qualifier . . . . _____               |
| DIVISION . . . . : EAST COAST _____    |
| DEPARTMENT . . . . _____              |
+-----+

```

After pressing F2 (Execute), the following Debit/Credit List panel appears. Place the cursor next to the first entry and press Enter.

```

USERID          CA PMA Chargeback          MM/DD/YY HH:MM:SS
__ Acctdefs  Cbdefs  Query  Data  Period  Options  Exit  Help
+-- CBDCRDL ----- Debit/Credit List -----+
|      Panel  Exit  Help                       |
+-----+
| Select a budget entry. Then select an action. |
|                                              |
| Version . . . . : PROD PROD                 |
| Period Number : 001 thru 001             |
| ORD Type . . . . :                         |
| Charge Element :                         |
| Qualifier . . . . :                         |
|                                              |
|          Amount  Description  More: - + ____  Row 0001 of 0005 |
| -          50.0000  E COAST-CPU-DEB-001  CREDIT |
| -          5.00000  E COAST-DIO-CRED-001  CREDIT |
| -          5.00000  E COAST                DEBIT |
|                                              |
| Enter  F7=Bkwd  F8=Fwd  F11=Expand |
+-----+
| Command ==> |
| F1=Help  F3=Exit  F4=Prompt  F9=Command  F10=Action Bar  F12=Cancel  PA1=Susp |

```

The Debit/Credit Entry panel appears and indicates you are in UPD mode. You can now make the required changes as shown on the following panel.

On the panel below, we have **typed over** the Debit Amount to make it a **CREDIT**.

```

USERID          CA PMA Chargeback          MM/DD/YY HH:MM:SS
__ Acctdefs  Cbdefs  Query  Data  Period  Options  Exit  Help

+-- CBDCRDE ----- Debit/Credit Entry -----+
| Panel  Exit  Help |
|-----|
| Type information and save. Or Delete. |
| Version . . . : PROD PROD          Mode . . . . : UPD |
| ORD Type . . . : MBJ              Period Number . 001 |
| Charge Element . CPU-CHARGE       credit Amount .    50.00 |
| Qualifier . . .                   Description . . E COAST |
| DIVISION . . . : EAST COAST_____ |
| DEPARTMENT . . . : _____ |
|-----|
| F5=Save  F6=Delete |
+-----+

Command ==>
F1=Help  F3=Exit  F4=Prompt  F9=Command  F10=Action Bar  F12=Cancel  PA1=Susp
    
```

Once you have completed the update, press F5 (Save). Exit out by pressing F3 (Exit). You see the result of your update on the Debit/Credit List panel.

```

+-- CBDCRDL ----- Debit/Credit List -----+
| Panel  Exit  Help |
|-----|
| Select a budget entry. Then select an action. |
| Version . . . : PROD PROD          DIVISION . . . . : EAST COAST |
| Period Number : 001 thru 001     DEPARTMENT . . . : |
| ORD Type . . . : |
| Charge Element : |
| Qualifier . . . : |
|-----|
|          Amount  Description  More: - + ____  Row 0001 of 0005 |
| -          50.0000  E COAST-CPU-CRED-001  CREDIT |
| -          5.00000  E COAST-DIO-CRED-001  CREDIT |
| -          5.00000  E COAST                CREDIT |
|-----|
| Enter  F7=Bkwd  F8=Fwd  F11=Expand |
+-----+
    
```

## Example 5: Deleting a Debit or a Credit Entry

Assume that you have created a Debit or a Credit entry while in INS (insert) mode, successfully *inserted* it into the table and then realized you made a mistake and must delete the record.

For example, you incorrectly entered a **Debit/Credit key**

- Version
- ORD Type
- Period Number
- Description
- Accounting level

and rather than do an update which overwrites the original record; you want to delete the incorrect record and then create a new one.

```

-----
| Debits/Credits |
|   Primary     |
|>F11          |
-----
| DB/CR Browse |
|   Criteria   |
|>F2          |
-----
|Debit/Cred List|
|or Expand List|
|>Enter       |
-----
|
| v
-----
| Debit/Credit |
|   Entry     |
|   Panel     |
-----

```

You must:

- Exit out to the Debits/Credits primary panel using F3 (Exit).
- Press F11 (Browse) which takes you to the DB/CR Browse Criteria panel.
- Enter your criteria and press F2 (Execute). This displays the Debit/Credit List panel.
- Select the entry you want to delete using the Enter key.
- When the Debit/Credit Entry panel appears for the selected entry, you are in UPD mode. Press F6 (Delete) to delete the record.

- An informational message appears telling you the record is deleted and the Mode changes to **EXIT**.
- Press **any** key to return to the Debit/Credit List panel where you can continue selecting other records to update or delete.

Following the path outlined in Example 5: Deleting a Debit or a Credit Entry at the Debits/Credits primary panel, indicate you want to perform a Browse by pressing F11. Fill in the DB/CR Browse Criteria panel as shown below.

```
+-- CBDCRDB --- DB/CR Browse Criteria -----+
|      Panel  Exit  Help                      |
|-----|
| Type browse criteria. Then Execute.         |
|                                             |
| Version . . . . . : PROD PROD              |
|                                             |
| Period Number . . 001 thru 001             |
| ORD Type . . . . . : ____                  |
| Charge Element . . _____              |
| Qualifier . . . . . : _____           |
| DIVISION . . . . . : EAST COAST_____    |
| DEPARTMENT . . . . _____              |
|-----+
+-----+
```

After pressing F2 (Execute), the following Debit/Credit List panel appears. Place the cursor next to the third entry and press Enter.

```
USERID          CA PMA Chargeback          MM/DD/YY HH:MM:SS
__ Acctdefs  Cbdefs  Query  Data  Period  Options  Exit  Help
+-- CBDCRDL ----- Debit/Credit List -----+
|      Panel  Exit  Help                      |
|-----|
| Select a budget entry. Then select an action. |
|                                             |
| Version . . . . . : PROD PROD              |
| Period Number : 001 thru 001             |
| ORD Type . . . . . :                       |
| Charge Element :                           |
| Qualifier . . . . . :                       |
|                                             |
|          Amount  Description  More: - + ____  Row 0002 of 0005 |
|-----|
| -           5.00000  E COAST-DIO-CRED-001  CREDIT |
| -           5.00000  E COAST                  DEBIT |
| -           1.00000  E COAST-DIO-CRED-001  DEBIT |
|-----|
| Enter  F7=Bkwd  F8=Fwd  F11=Expand          |
|-----+
| Command ==>                                  |
| F1=Help  F3=Exit  F4=Prompt  F9=Command  F10=Action Bar  F12=Cancel  PA1=Susp |
+-----+
```

The Debit/Credit Entry panel, shown on the next page, appears and indicates you are in UPD (update) mode.

To delete the record shown below, simply press F6 (Delete).

```

USERID          CA PMA Chargeback          MM/DD/YY HH:MM:SS
__  Acctdefs  Cbdefs  Query  Data  Period  Options  Exit  Help

+-- CBDCRDE ----- Debit/Credit Entry -----+
| Panel  Exit  Help |
|-----|
| Type information and save. Or Delete. |
| Version . . . : PROD PROD          Mode . . . . : UPD |
| ORD Type . . . : MBJ              Period Number . 001 |
| Charge Element . DISK-IO_____ DEBIT Amount .      1.00 |
| Qualifier . . . :                 Description . . E COAST-DIO-CRED-001 |
| DIVISION . . . : EAST COAST_____ |
| DEPARTMENT . . . : _____ |
|
| F5=Save  F6=Delete |
+-----+

Command ==>
F1=Help  F3=Exit  F4=Prompt  F9=Command  F10=Action Bar  F12=Cancel  PA1=Susp

```

**Note:** You receive a message informing you the record was successfully deleted. The Mode field now indicates you are in EXIT mode.

```

USERID          CA PMA Chargeback          MM/DD/YY HH:MM:SS
__  Acctdefs  Cbdefs  Query  Data  Period  Options  Exit  Help

+-- CBDCRDE ----- Debit/Credit Entry -----+
| Panel  Exit  Help |
|-----|
| Type information. Then select an action. |
| Version . . . : PROD PROD          Mode . . . . : EXIT |
|                                     &TRIANGLE. |
|
|
+-----+

```

You exit out by pressing **any** key.

**Note:** As you exit out, you should verify that the entry was deleted from the Debit/Credit List panel. That is, the total number of rows reflected on the scroll bar is decreased by one (as shown on the next panel).

The following Debit/Credit List panel no longer displays the E COAST-DIO-CRED-001 DEBIT entry which we deleted.

```

USERID          CA PMA Chargeback          MM/DD/YY HH:MM:SS
__ Acctdefs  Cbdefs  Query  Data  Period  Options  Exit  Help
+-- CBDCRDL ----- Debit/Credit List -----+
| Panel  Exit  Help |
|-----|
| Select a budget entry. Then select an action. |
| Version . . . : PROD PROD          DIVISION . . . : EAST-COAST |
| Period Number : 001 thru 001      DEPARTMENT . . . : |
| ORD Type . . . : |
| Charge Element : |
| Qualifier . . . : |
| |
|          Amount  Description  More: - + ____  Row 0002 of 0004 |
| -          5.00000  E COAST-CPU-CRED-001  CREDIT |
| -          5.00000  E COAST                DEBIT |
| |
| Enter  F7=Bkwd  F8=Fwd  F11=Expand |
+-----+
Command ==>
F1=Help  F3=Exit  F4=Prompt  F9=Command  F10=Action Bar  F12=Cancel  PA1=Susp

```

# Chapter 8: Using Period Functions

You invoke Period functions by selecting **Period** from the CA PMA Chargeback Primary Panel's action bar or by entering **P** in the fast path area of the Primary Panel's action bar. The following Period Functions pull-down then appears. You make selections by placing your cursor next to the function you want to perform and pressing **Enter**.

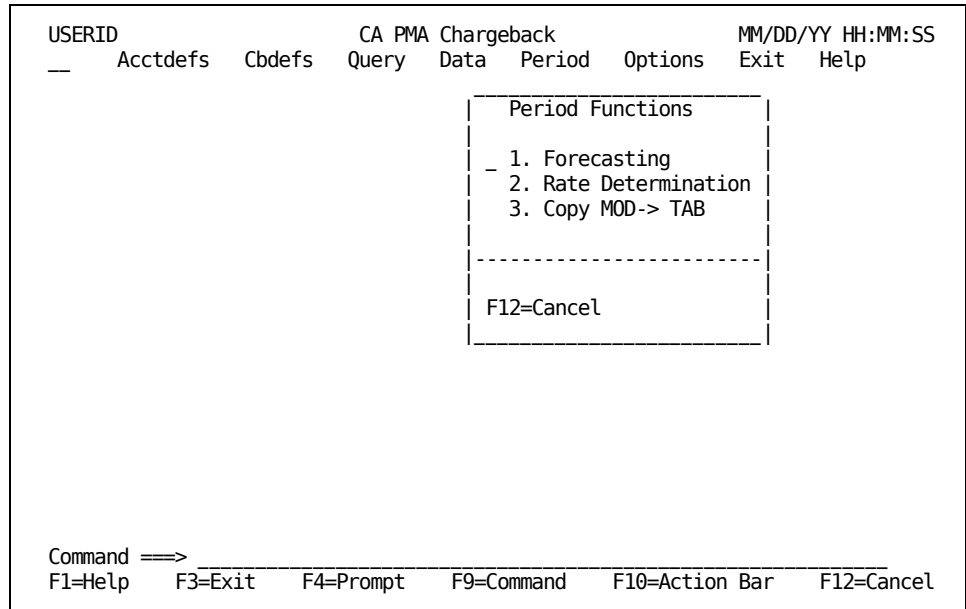

A description of these selections follows.

The Period function enables you to perform the following:

### 1. Forecasting

Allows you to view and optionally modify the contents of the CCCMOD table generated during batch processing.

### 2. Rate Determination

Enables you to establish or determine accurate rates for future accounting periods based on forecasted utilization levels and cost recovery goals.

### 3. Copy MOD -> TAB

Copies the contents of the CCCMOD table to the CCCTAB table-if you used a copy command to create the CCCMOD table.

## Forecast Panels

The CA PMA Chargeback forecast process projects future unit and charge consumption. You perform forecasting in two steps:

- **Batch:** The forecast batch process is the first step. It generates a CCCMOD table based on the contents of the CCCTAB table, and the type of forecast method you specify. You can customize the forecast generated to suit your particular needs. Numerous control parameters allow you to do so. For more information, see the section titled *Batch Forecasting* in Chapter 11.
- **Online:** Once CA PMA Chargeback successfully generates the CCCMOD table, you can view its contents using the Period function's forecast option.

The Forecast panel set allows you to view and optionally modify the CCCMOD table. The following panels make up the forecast panel set:

- Overall Forecast Results panel
- Forecast Elements List panel
- Forecast Element panel
- Forecast Qualifiers List panel
- Forecast Qualifier panel

You perform forecasting on the contents of the CCCMOD table to ensure the integrity of the CCCTAB table. On entry to the Forecast function, CA PMA Chargeback checks if a CCCMOD table exists.

- If a CCCMOD table does **not** exist, CA PMA Chargeback presents you with the following panel.

```
+-- CBOFCTP --- Forecast Primary -----+
|
| No Records were found on the CCCMOD Table. |
| You must create the CCCMOD Table in Batch. |
| Press Enter to exit this Panel.           |
|
| Enter                                     |
+-----+
```

- If a CCCMOD table exists:

CA PMA Chargeback verifies that the version used in creating the CCCMOD table is the same as the version specified in the Options function. If the two versions match, you can continue to view forecast results. If not, the following panel appears.

```
+-- CBOFACTS -- Period Specifications ----+
|
| Press Enter to exit.
| Version found on CCCMOD = PRODABCD
| does not match
| Version found in Options = PROD
|
| Enter
+-----+
```

To view forecast results, you must:

- Exit the Forecast function
- Select Options from the Primary panel's action bar
- Change the existing version to the one named on the CCCMOD table
- Return to the Forecast function

You can now view forecast results.

## Overall Forecast Results Panel

The Overall Forecast Results panel allows you to view the **total** charges for all elements, for **both** forecasted and existing periods. Hence, CA PMA Chargeback joins and displays records from the CCCTAB and CCCMOD tables on the Overall Forecast Results panel.

**Note:**

- You can distinguish periods from the CCCMOD table from those in the CCCTAB table by the \* symbol to the left of the Prd column (see A. below).
- The Amount column shows the total charge for each period. The amount can be in units (U), thousands (K), millions (M), billions (B), or trillions (T). The S column specifies the scale factor used for each forecasted period (see B. below).
- The first value of the scale represents the smallest charge. The last value of the scale represents the largest charge plus ten percent (see C. below).

```

USERID          CA PMA Chargeback          MM/DD/YY HH:MM:SS
  Acctdefs  Cbdefs  Query Data Period  Options  Exit  Help
+-- CBOFCTO ----- Overall Forecast Results -----+
|
| Panel Exit Help
|-----|
| View information. Then select an action.
|
| Prd Charge -----> Amount S B.
| A.
| * 003 *****                               52.3394 K
|   002 *****                               261.737
|   001 *                                       11.5957
|
|
| C. 11.5957  66.8587  122.121  177.384  232.647  287.911
|
| F7=Bkwd  F8=Fwd  F11=Elements
+-----+
Command ==> _____
F1=Help  F3=Exit  F4=Prompt  F9=Command  F10=Action Bar  F12=Cancel
    
```

A description of the Overall Forecast Results panel follows.

**Access**

The Overall Forecast Results panel appears when one of these events occurs:

- You type PF in the fast path area of the Primary Panel's action bar.
- You choose Forecasting on the Period Functions pull-down.

```

-----
| Period Funct. | _____
| Pull-Down    |         |
|>Forecasting  |         v
    
```

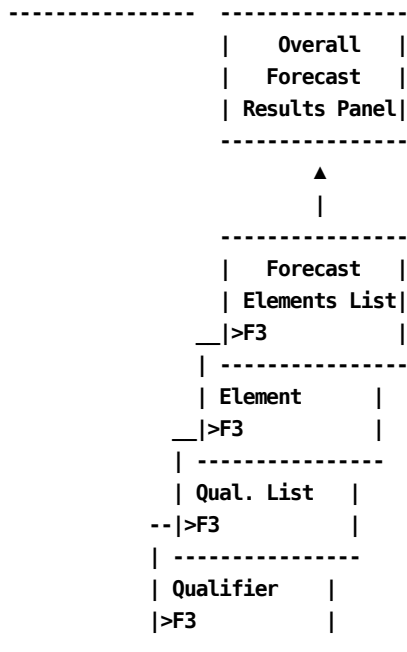
**Scrolling**

F7 and F8 let you scroll backward and forward through the Overall forecast Results panel. You can also use the scroll bar to move through the panel.

**Pathway****F11**

**(Elements)** Provides you with a listing of all the ORD types and charge elements which make up the Overall Results panel. CA PMA Chargeback displays ORD Types and Charge Elements by period number.

## Example 1: Forecasting Using the COPY Algorithm

Periods on the Overall Forecast Results panels appear differently, depending on the forecast method you use to create the CCCMOD table. The following set of examples demonstrate this.

If you submit the following *batch* control statements, CA PMA Chargeback copies periods 001 and 002 from the CCCTAB table to the CCCMOD table. You can use the outcome of this forecast to perform *What if analysis*.

For more information on using the batch process for forecasting, see Batch Forecasting (CAKRFCB).

```

VERSION = PRODABCD
ALGORITHM = COPY
START_PERIOD = 1
END_PERIOD = 2
KEEP_STRUCTURE = 1
MODIFIER = NO
    
```

After you submit the above control statements, CA PMA Chargeback generates the CCCMOD table. The panel below shows the results of the above forecast. Data from Periods 1 and 2 in the CCCTAB have been copied to the CCCMOD table.

```

USERID          CA PMA Chargeback          MM/DD/YY HH:MM:SS
  Acctdefs  Cbdefs  Query  Data  Period  Options  Exit  Help
+-- CBOFACTO ----- Overall Forecast Results -----+
| Panel Exit Help |
|-----|
| View information. Then select an action. |
|-----|
| Prd Charge -----> Amount S |
| * 002 ***** | 285.732 U |
| 002 ***** | 285.732 |
| 001 * | 7.43417 |
| * 001 * | 7.43417 | | | | |
|---|---|---|---|---|---|
| 7.43417 | 68.8085 | 130.182 | 191.556 | 252.930 | 314.306 |
|-----|
| F7=Bkwd  F8=Fwd  F11=Elements |
+-----+
Command ==>
F1=Help  F3=Exit  F4=Prompt  F9=Command  F10=Action Bar  F12=Cancel  PA1=Susp
    
```

## Example 2: Forecasting Using the Line Algorithm (Results)

This example shows how to forecast one period using the *Line* algorithm based on periods 001 and 002 from the CCCTAB table. You use the following batch control statements to produce the display shown below.

```
VERSION = PRODABCD
ALGORITHM = LINE
START_PERIOD = 1
END_PERIOD = 2
KEEP_STRUCTURE = 1
MODIFIER = NO
NUMBER_TO_FORECAST = 1
```

After you submit these control statements, CA PMA Chargeback generates a CCCMOD table. The following Overall Forecast Results panel displays the outcome of this forecast.

- CA PMA Chargeback displays existing periods, 1 and 2 along with the forecasted period (period 3) for comparisons purposes.
- You can distinguish the forecasted period by the asterisk to the left of the period number.
- The scale (S) used is in thousands (K).

```

USERID                CA PMA Chargeback                MM/DD/YY HH:MM:SS
___ Acctdefs  Cbdefs  Query  Data  Period  Options  Exit  Help
+-- CBOFCTO ----- Overall Forecast Results -----+
|   Panel  Exit  Help
|-----+
|   View information. Then select an action.
|
|   Prd Charge ----- More: - + _____ Row 0001 of 0003
|   Amount S
| * 003 *****
| 002 *****
| 001 *
|
|   |   |   |   |   |
| 11.5957  66.8587  122.121  177.384  232.647  287.911
|
|   F7=Bkwd  F8=Fwd  F11=Elements
+-----+
Command ==>
F1=Help  F3=Exit  F4=Prompt  F9=Command  F10=Action Bar  F12=Cancel  PA1=Susp.
```

### Example 3: Forecasting Using the Smooth Algorithm (Results)

This example shows how to forecast one period using the *SMOOTH* algorithm based on periods 001 and 002 in the CCCTAB table.

The following are the control statements you specify during batch processing:

```

VERSION = PRODABCD
ALGORITHM = SMOOTH
START_PERIOD = 1
END_PERIOD = 2
KEEP_STRUCTURE = 1
MODIFIER = NO
NUMBER_TO_FORECAST = 1
ALPHA = .1
DELTA = .1
    
```

After you submit the above control statements, CA PMA Chargeback generates the CCCMOD table. The results of the batch process display on the Overall Forecast Results panel as shown next.

```

USERID          CA PMA Chargeback          MM/DD/YY HH:MM:SS
  ___ Acctdefs  Cbdefs  Query  Data  Period  Options  Exit  Help
+-- CBOFCT0 ----- Overall Forecast Results -----+
|   Panel  Exit  Help  |
|-----|
|   View information. Then select an action.   |
|-----|
|   Prd Charge -----> Amount S             |
| * 003 *****                               | 52.3394 K |
| 002 *****                               | 261.737  |
| 001 *                                       | 11.5957  | | | | |
|---|---|---|---|---|---|
|           |           |           |           |           |           |
|   11.5957  66.8587  122.121  177.384  232.647  287.911  |
|-----|
|   F7=Bkwd  F8=Fwd  F11=Elements             |
+-----+
Command ==>
F1=Help  F3=Exit  F4=Prompt  F9=Command  F10=Action Bar  F12=Cancel  PA1=Susp
    
```

The following panels show the Overall Forecast Results using the different Forecast methods.

#### Forecast Periods Using COPY Algorithm

```

+-----+
| View information. Then select an action.                                     |
|                                                                              |
|                                                                              |
| Prd Charge -----> Amount S                                         More: - + ____ Row 0001 of 0004 |
| * 002 *****                                                    261.737 K |
| 002 *****                                                    285.737 |
| 001 *                                                            11.5957 |
| * 001 *                                                            11.5957 |
|                                                                              |
|          |          |          |          |          |          |          |
|        11.5957   66.8587   122.121   177.384   232.647   287.911 |
|                                                                              |
| F7=Bkwd  F8=Fwd  F11=Elements |
+-----+
    
```

**Forecast Periods Using Line Algorithm**

```

+-----+
| View information. Then select an action.                                     |
|                                                                              |
|                                                                              |
| Prd Charge -----> Amount S                                         More: - + ____ Row 0001 of 0003 |
| * 003 *****                                                    181.607 K |
| 002 *****                                                    261.737 |
| 001 *                                                            11.5957 |
|                                                                              |
|          |          |          |          |          |          |          |
|        11.5957   66.8587   122.121   177.384   232.647   287.911 |
|                                                                              |
| F7=Bkwd  F8=Fwd  F11=Elements |
+-----+
    
```

**Forecast Periods Using Smooth Algorithm**

```

+-----+
| View information. Then select an action.                                     |
|                                                                              |
|                                                                              |
| Prd Charge -----> Amount S                                         More: - + ____ Row 0001 of 0003 |
| * 003 *****                                                    52.3394 K |
| 002 *****                                                    261.737 |
| 001 *                                                            11.5957 |
|                                                                              |
|          |          |          |          |          |          |          |
|        11.5957   66.8587   122.121   177.384   232.647   287.911 |
|                                                                              |
| F7=Bkwd  F8=Fwd  F11=Elements |
+-----+
    
```

## Forecast Elements List Panel

The Forecast Elements List panel displays a list of the ORD Types and Charge Elements used in the forecast (see 1. below). CA PMA Chargeback displays each combination of ORD Type and Charge Element by period number. Initially, the panel displays values for the first period forecasted (see A. below).

Each display amount is a breakdown of the total amount (see B. below) for the period shown on the Overall Forecast Results panel. If you change the Fcast in field from CHARGES to UNITS, CA PMA Chargeback automatically presents **unit** values in the Amount column.

A Y in the Mod column indicates that CA PMA Chargeback applied a modifier to the Charge Element. The following panel shows the ORD Types and Charge Elements that make up forecast period 3. Results from the Overall Forecast Results panel remain for comparison purposes (see 2. below).

```

USERID          CA PMA Chargeback          MM/DD/YY HH:MM:SS
  Acctdefs  Cbdefs  Query  Data  Period  Options  Exit  Help
+-- CBOFCTE ---- Forecast Elements List -----+-----+
| Panel Exit Help                                1.          2. |
|-----|-----|
| View forecast information. Then select an action. |
| More: < - + > ____ Row 0001 of 0005             |
|   A.                                             |
| Period = 003                                Fcast in CHARGES |
|                                             B. |
| C Ord Element                               Mod Amount |
| - MBJ CPU-CHARGE                           36.5789       52.3394 K |
| - MBJ DISK-CHARGE                          265.5270       261.737 |
| - MBJ PRINT-CHARGE                          1.1960         11.5957 |
| - MBJ SPEC-CHARGE                          52009.9000 |
| - MBJ TAPE-CHARGE                          26.2000 |
| - |
| - |
| F5=<<Per  F6=>>Per  F7=Bkwd  F8=Fwd |
+-----+-----+
Command ==>
F1=Help  F3=Exit  F4=Prompt  F9=Command  F10=Action Bar  F12=Cancel  PA1=Susp
    
```

A description of the Forecast Elements List panel follows.

### Access

The Forecast Elements List panel appears when one of these events occurs:

- You press **F11** (Elements) on the Overall Forecast Results panel shown in Overall Forecast Results Panel.
- You return from the Forecast Element, the Forecast Qualifiers List, or the Forecast Qualifier panels.

```

-----
|Overall Fore. | _____
|Results Panel |         |
|>F11         |         v
-----
| Forecast     |
|Elements List |
| Panel       |
-----
      ▲
      |
-----
|Forecast Elem.|
|  Panel      |
|>F3         |
-----
| Qual. List  |
|-->F3       |
-----
| Qualifier   |
|>F3         |
-----

```

### Scrolling

F7 and F8 let you scroll backward and forward by ORD element through the Forecast Elements List panel. You can also use the scroll bar, as explained on page Sample List Panel, to move through the list.

You can also scroll left and right, by period number, through the Forecast Elements List panel using F5 and F6 or by placing the cursor on the < or > symbol on the scroll bar and pressing Enter.

### Input

The following Forecast Elements List panel fields are available for input:

**Note:** CA PMA Chargeback uses the following fields for display as well as input purposes. When you first select the panel, these fields contain the values displayed on the Overall Forecast Results panel for the first forecasted period. You can enter new values by typing over existing values.

#### Period

A three-character numeric field used to specify the projected period for which CA PMA Chargeback displays elements. Initially, CA PMA Chargeback presents the first projected period in this field. You can change this value by specifying another projected period and pressing Enter. CA PMA Chargeback automatically presents charge information for the new period.

#### Fcast in

A field used to specify whether the panel presents charges or units. The default value is CHARGES. If you change the default to UNITS, CA PMA Chargeback adjusts the values in the Amount column to display units.

**Amount**

Specifies the forecasted amount of units or charges for a given charge element for the period displayed.

The following are acceptable commands in the Command column:

**P**

**(Plot)** Provides a new forecast projection in charges or in units, for the charge element selected.

**C**

**(Calculate)** Prorates all qualifiers associated with a charge element for the period based on the value you specify. UNITS must be specified in the Fcast in field, otherwise an error message results.

For example, if you change the unit amount for a charge element and enter C in the C (command) column, CA PMA Chargeback computes the percentage of change between the projection and the value you specify. It then applies this percentage to all subordinate qualifiers for the given period. CA PMA Chargeback also calculates the charge for the specified charge element.

**Q:**

**(Qualifiers)** Provides a listing of all the qualifiers associated with the specified charge element.

**Pathways**

**P Command**

(Plot) Displays the Forecast Element panel.

**Q Command**

(Qualifiers) Displays the Forecast Qualifiers List panel.

**Enter**

By entering a P (Plot), or a Q (Qualifiers) in the C command column next to an element and pressing **Enter**, you can perform the function specified.

## Forecast Element Panel

The Forecast Element panel presents future usage of a charge element by charges or by units for **all** forecasted periods. For comparison purposes, the panel also displays the charges or units for existing periods.

### Note:

- You can distinguish periods from the CCCMOD table from those in the CCCTAB table by the \* symbol to the left of the Prd column (see A. below).
- The Amount column shows the total charges or units for each period. The amount can be in units (U), thousands (K), millions (M), billions (B), or trillions (T). The S column displays the factor used for each forecasted period (see B. below).
- The first value of the scale represents the smallest charge. The last value of the scale represents the largest charge plus ten percent (see C. below).

The following panel displays both forecast and actual data.

```

USERID          CA PMA Chargeback          MM/DD/YY HH:MM:SS
--- Acctdefs  Cbdefs  Query  Data  Period  Options  Exit  Help
+-- CBOFCTD ----- Forecast Element -----+
|
| Panel Exit Help
|-----+
| View Element MBJ CPU-CHARGE          in CHARGES
|
| More: - + ____ Row 0001 of 0003
|
| A. Prd Amount                               S  B.
| * 003 *                                     3.65789 U
| 002 *****                               22.2562
| 001 *****                               34.0892
|
|
| C.      |      |      |      |      |      |
| 3.65789 10.4259 17.1939 23.9619 30.7299 37.4981
|
| F7=Bkwd F8=Fwd F11=Qualifiers
+-----+

Command ==>
F1=Help F3=Exit F4=Prompt F9=Command F10=Action Bar F12=Cancel PA1=Susp

```

A description of the Forecast Element panel follows.

### Access

The Forecast Element panel appears when one of these events occurs:

- You enter P for Plot in the C column next to an element, on the Forecast Elements List panel shown in Forecast Elements List Panel.
- You return from the Forecast Qualifiers List, or the Forecast Qualifier panels.

-----

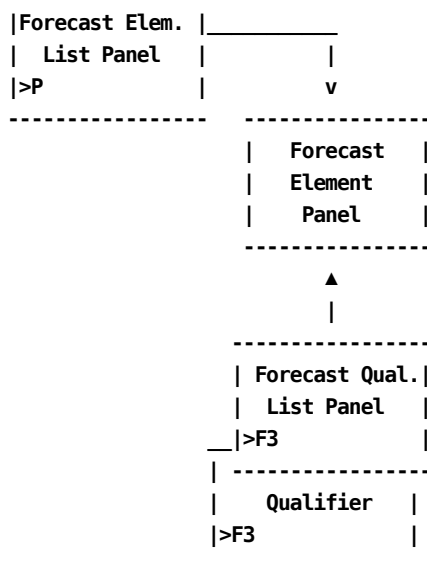

### Scrolling

F7 and F8 let you scroll backward and forward through the Forecast Element panel. You can also use the scroll bar, as explained on Sample List Panel, to move through the panel.

### Input

The following Forecast Element panel field is available for input:

**in**

Acceptable entries are:

- Units
- Charges

### Pathway

#### F11

**(Qualifiers)** Gives you a listing of the Qualifiers associated with the charge element displayed on the Forecast Element panel. CA PMA Chargeback displays qualifiers by period number.



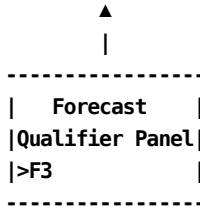

**Scrolling**

F7 and F8 let you scroll backward and forward through the Forecast Qualifiers List. You can also use the scroll bar, as explained on page Sample List Panel, to move through the list.

You can also scroll left and right, by period number, through the Forecast Qualifiers List panel using F5 and F6 or by placing the cursor on the < or > symbol on the scroll bar and pressing Enter.

**Input**

The following Forecast Qualifiers List panel fields are available for input:

**Note:** CA PMA Chargeback uses the following fields for display purposes as well as input. When you first select the panel, these fields display qualifiers for the first projected period of the charge element on the Forecast Element panel. You can overwrite this value with one of your own.

**Period**

A three-digit numeric field that specifies the projected period for which CA PMA Chargeback displays qualifiers. Initially, CA PMA Chargeback displays the first projected period within this field. You can change the period by specifying another projected period and pressing **Enter**.

**Fcast in**

Acceptable values are:

- Units
- Charges

**C**

**(Command column)** Valid commands are:

P: **(Plot)** Displays a new forecast projection in charges or in units, for the qualifier selected.

C: **(Calculate)** Prorates the projected unit amount for a given element based on the value you specify. When using this command, you must specify UNITS in the Fcast in field.

For example, if you change the unit amount for a qualifier and specify C in the C (command) column, CA PMA Chargeback calculates the percentage of change between the projection and the value you specify. It then applies this percentage to the total unit amount for the given element for the specified period. CA PMA Chargeback also changes the projected charge for the element for the period.

**Amount**

Specifies the forecasted amount of units or charges for the qualifier for the period displayed.

## Forecast Qualifier Panel

The Forecast Qualifier panel projects the future charge or unit usage of a charge element's qualifier for **all** forecasted periods. The panel also presents the qualifier's charge or unit usage for existing periods.

**Note:**

- You can distinguish forecast periods from existing periods by the\* symbol to the left of the Prd column (see A. below).
- The Amount column shows the total charges or units for each period. The amount can be in units (U), thousands (K), millions (M), billions (B), or trillions (T). The S column shows the factor used for each forecasted period (see B. below).
- The first value of the scale represents the smallest charge. The last value of the scale represents the largest charge plus ten percent (see C. below).

The panel below shows qualifier information for both forecasted and existing periods.

```

USERID          CA PMA Chargeback          MM/DD/YY HH:MM:SS
--- Acctdefs  Cbdefs  Query  Data  Period  Options  Exit  Help
+-- CBOFCTG ----- Forecast Qualifier -----+
|
| Panel Exit Help
|-----+
| View Element MBJ CPU-CHARGE      Qual @SHIFT1          in CHARGES
|
| More: - + ____ Row 0001 of 0003
| A. Prd Amount                                     S  B.
| * 003 *                                           3.65789 U
| 002 *****
| 001 **                                           4.0892
|
|
| C.      | 3.65789  4.96267  6.26745  7.57223  8.87701  10.1818
|
| F7=Bkwd  F8=Fwd
|-----+
Command ==> _____
F1=Help   F3=Exit   F4=Prompt   F9=Command   F10=Action Bar   F12=Cancel
    
```

A description of the Forecast Qualifier panel follows

**Access**

The Forecast Qualifier panel appears when you enter P for Plot in the C column next to a qualifier on the Forecast Qualifiers List panel shown in Forecast Qualifiers List Panel.

-----  
**|Forecast Qual. |** \_\_\_\_\_

```
| List Panel |           |
|>P         |           |
-----|-----
                | Forecast |
                | Qualifier |
                | Panel   |
                -----
```

### Scrolling

F7 and F8 let you scroll backward and forward through the Forecast Qualifier panel. You can also use the scroll bar, as explained on page Sample List Panel, to move through the panel.

### Input

The following Forecast Qualifier panel field is available for input:

**in**

Acceptable values are:

- Units
- Charges

### Example 1: Adjusting the Amount of the SHIFT1 Qualifier

You can make manual adjustments to the unit amount of any of the Forecast Qualifiers List elements by:

- Changing the **Fcast in** field from CHARGES to UNITS
- Specifying a new qualifier amount by keying over the amount generated by the system
- Entering a C (calculate) in the C command column next to the element and pressing Enter

Once CA PMA Chargeback performs all calculations, it redisplay the screen. The value in the Amount column for the qualifier may be different than the value you originally specified. This is due to rounding.

To adjust the amount of the @Shift1 qualifier on the panel below:

- Change the **Fcast in** field from CHARGES to UNITS. When you do this, CA PMA Chargeback automatically presents unit amounts for the qualifiers on the panel.
- Change the unit amount of the @SHIFT1 qualifier from 2.00000 to 1.50000 units.
- Enter **C** (Calculate) in the C command column for qualifier @SHIFT1.

```

USERID                CA PMA Chargeback                MM/DD/YY HH:MM:SS
__  Acctdefs  Cbdefs  Query  Data  Period  Options  Exit  Help
+-- CBOFCTQ  -----Forecast Qualifiers List-----+-----+
|  Panel  Exit  Help  |
|-----|
|  View forecast information. Then select an action.  |
|  More: < - + > ____ Row 0001 of 0002              |
|  Period = 003  Element MBJ CPU-CHARGE              |
|  C Qualifiers          Mod Amount  Fcast in UNITS__  |
|  C @SHIFT1              1.50000_____  |
|  -  |
|  -  |
|  -  |
|  -  |
|  -  |
|  -  |
|  -  |
|  F5=<<Per  F6=>>Per  F7=Bkwd  F8=Fwd  |
+-----+-----+
|  3.65789  U  |
|  22.2562   |
|  34.0892   |
|  |
|  37.4981   |
|-----+-----+
Command ==> _____
F1=Help  F3=Exit  F4=Prompt  F9=Command  F10=Action Bar  F12=Cancel
    
```

When you press **Enter**, CA PMA Chargeback performs the following computations.

- It computes the difference between the initial value for the qualifier and the new adjusted value.

- CA PMA Chargeback applies this difference to the unit amount of the charge element to which the qualifier belongs
- It recomputes the charge associated with the element using the new unit amount.

The next panel shows the new values generated on the Forecast Elements List panel after you change the unit amount of the @SHIFT1 qualifier and CA PMA Chargeback recomputes the charge amount. Note that the charge amount displayed for element CPU-CHARGE is different than the original value displayed in Forecast Elements List Panel.

USERID	CA PMA Chargeback	MM/DD/YY HH:MM:SS
___ Acctdefs Cbdefs Query Data Period Options		Exit Help
+-- CBOFCTE ---- Forecast Elements List -----+-----+-----+		
Panel Exit Help		
-----   -----		
View forecast information. Then select an action.		
More: < - + > ___ Row 0001 of 0001		
-----   -----		
Period = 003   Fcast in CHARGES		Row 0001 of 0003
		--> Amount S
C Ord Element   Mod Amount		52.3394 K
_ MBJ CPU-CHARGE   27.43418		261.737

## Rate Determination Panels

Rate Determination panels enable you to establish rates for recovery purposes. Rate determination can only be performed if a CCCMOD table exists, otherwise an error message results. The Rate Determination panel set consists of:

- Rate Determination (Elements) Entry panel
- Rate Determination (Qualifiers) Entry panel

## Rate Determination (Elements) Entry Panel

The Rate Determination (Elements) Entry panel acts like a spreadsheet. It provides data entry and data display capabilities for rate information.

On entry to the panel, CA PMA Chargeback displays rates generated from forecasting. These rates can be overridden with values you specify. If you enter C (calculate) in the C (command) column, CA PMA Chargeback uses any entry you make to recompute all displayed values for the charge element and any subordinate qualifiers.

- CA PMA Chargeback uses the Cost column exclusively for entry purposes (see D. on the next panel). This column works with the C (command) column to recompute the values displayed based on any entries you specify.
- The Ord and Elements columns list the names of the ORD Types and Charge Elements for which CA PMA Chargeback displays rate information (see A. on the next panel)
- The M column indicates whether or not the application applied a modifier to an element (see B. on the next panel)
- CA PMA Chargeback uses the Units column and Totals for Units field for display purposes. These fields can only be set by the Forecasting function (see C. and E. on the next panel)
- All numeric display/entry fields, except %Of-Tot can be in units (U), thousands (K), millions (M), billions (B) or in trillions (T). The factor used for each display/entry field is shown next to the field.

A sample Rate Determination (Elements) Entry panel follows.

```

USERID          CA PMA Chargeback          MM/DD/YY HH:MM:SS
__  Acctdefs  Cbdefs  Query  Data  Period  Options  Exit  Help
+-- CBORTEEE ----- Rate Determination Entry -----+
  Panel  Exit  Help
+-----+
Enter rate determination data. Then select an action or Enter.

  Period : 005          More: < - + > ____ Row 0001 of 0001
    A.          B.  C.          D.
C Ord Elements          M Units    Avg-Rate  Proj-Chg  %Of-Tot  Cost    S
|  MBJ CPU-CHARGE          6.99999 U 4.16666 U 28.3333 U 100.000  _____ -
|  _____              _____ -
|  _____              _____ -
|  _____              _____ -
|
| E. Totals          6.99999 U          28.3333 U
|
| Enter  F5=<Per  F6=>Per  F7=Bkwd  F8=Fwd  F11=Generate
+-----+

Command ==>
F1=Help  F3=Exit  F4=Prompt  F9=Command  F10=Action Bar  F12=Cancel
    
```



**C: (Calculate)** Calculate any changes you specify for the column entries. CA PMA Chargeback prorates changes across all subordinate qualifiers for the period.

**Q: (Qualifiers)** Displays any qualifiers associated with a given charge element.

#### **Cost**

An entry field used to specify the charge to be recovered. The system automatically adjusts the rates to recover this amount.

#### **S**

A scale which indicates whether the cost for each charge element is in thousands (K), units (U), millions (M), billions (B), or in trillions (T).

#### **Pathways**

##### **Enter**

By entering a C(Calculate), or a Q(Qualifiers) in the C command column next to an element and pressing **Enter** you can perform the function specified.

##### **F11**

**(Generate)** Replaces the existing rates in the development set of the RATETAF and ELEMATF tables to the ones generated on the Rate Determination panels.

##### **Note:**

- If the records in the CCCMOD table do not match therecords in the rate tables, rate generation fails.
- When you select **F11** to automatically generate rates, you **must** commit the new rates before you use them.
- You can enter Rates on the rate table automatically using **F11** or manually using the Cbdefs option. If you use **F11** CA PMA Chargeback deletes any rates you enter manually. You should therefore use this option with caution.

## Rate Determination (Qualifiers) Entry Panel

The Rate Determination (Qualifiers) Entry panel works the same way as the Rate Determination (Elements) Entry panel (section Rate Determination (Elements) Entry Panel). The panel allows you to override existing rate information with your own values. It recalculates the values of the display/entry fields based on the changes you specify.

The panel below is a sample Rate Determination (Qualifiers) Entry Panel.

### Note:

- The Qualifiers column lists the name of the qualifiers for which CA PMA Chargeback displays rate information (see A. on the next panel)
- The Mod column indicates whether CA PMA Chargeback applied a modifier to the qualifier record or not (see B. on the next panel)
- The application uses the Units column and Totals for Units fields for display purposes. These fields can only be set by using the Forecasting function (see C. and D. on the next panel)
- All numeric display/entry fields, except %Of-Tot can be in units (U), thousands (K), millions (M), billions (B), or in trillions (T). The factor used for each display field is shown next to the field.

```

USERID                CA PMA Chargeback                MM/DD/YY HH:MM:SS
__  Acctdefs  Cbdefs  Query  Data  Period  Options  Exit  Help
+-- CBORTEQ ----- Rate Determination Entry -----+
| Panel  Exit  Help
|-----|
| Enter rate determination data for MBJ CPU-CHARGE .
|
|   Period : 005                More: < - + > ____ Row 0001 of 0002
|   A.                B.  C.
| C  Qualifiers      Mod Units      Rate  Proj-Chg  %Of-Tot  Cost  S
|   @DEFAULT          3.00000 U 4.99999 U 14.9999 U 52.941  _____ -
|   @SHIFT1           3.99999 U 3.33333 U 13.3333 U 47.058  _____ -
|   -                 -             -             -             -             -
|   -                 -             -             -             -             -
|   -                 -             -             -             -             -
|
| D. Totals                6.99999 U                28.3333 U
|
| Enter  F5=<Per  F6=>Per  F7=Bkwd  F8=Fwd
+-----+

Command ==> _____
F1=Help  F3=Exit  F4=Prompt  F9=Command  F10=Action Bar  F12=Cancel

```

A description of the Rate Determination (Qualifiers) Entry panel follows.

### Access

The Rate Determination (Qualifiers) Entry panel appears when you enter **Q** for Qualifiers in the C column next to an element on the Rate Determination (Elements) Entry panel.

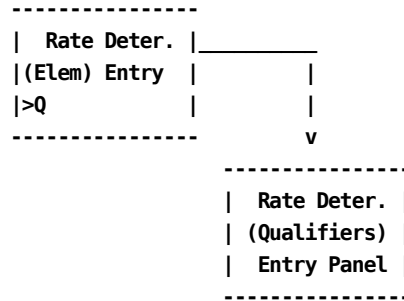

**Scrolling**

F7 and F8 let you scroll backward and forward through the Rate Determination Entry panel. You can also use the scroll bar, as explained on page Sample List Panel, to move through the panel.

You can also scroll left and right, by period number, through the Rate Determination Entry panel using F5 and F6 or by placing the cursor on the < or > symbol on the scroll bar and pressing Enter.

**Input**

The following Rate Determination Entry panel fields are available for input:

**Period**

A three-digit numeric field used to specify the period for which CA PMA Chargeback displays rates. If you want rate information for another period, specify the new period in place of the one displayed and press **Enter**.

**C**

**(Command column)** used to calculate **C** any changes you specify for the column entries. Changes made to qualifier values affect the value of the associated charge element for the given period.

**Cost**

Field used to specify the charge to be recovered. The system automatically adjusts rates to recover this amount.

**S**

**(Scale)** Field used to indicate whether the cost for each qualifier is in thousands (K), units (U), millions (M), billions (B), or in trillions (T).

**Pathway**

**Enter**

By entering a C. in the command column next to a qualifier, and pressing **Enter** CA PMA Chargeback recalculates the values for all numeric fields using any entries you specify.

### Example 1: Recovering Charges for Element CPU-CHARGE

The following example shows how to specify charges to be recovered on the Rate Determination (Elements) Entry panel. CA PMA Chargeback computes the rates needed to achieve this result, and prorates any subordinate qualifiers for a charge element according to the value you specify in the Cost column.

Once CA PMA Chargeback performs all calculations, it resets the panel with new values. Due to rounding factors, the new charge value may be slightly different than the value you specify in the Cost column.

To recover charges:

- Enter 35 in the Cost column and U in the S column for element CPU-CHARGE (see A. and B. on the next panel)
- Enter C (calculate) in the C command column next to the element (see C. on the next panel)

```

USERID          CA PMA Chargeback          MM/DD/YY HH:MM:SS
  Acctdefs  Cbdefs  Query  Data  Period  Options  Exit  Help
+--- CBORTEE ----- Rate Determination Entry -----+
  Panel  Exit  Help
-----+-----
Enter rate determination data. Then select an action or Enter.

  Period : 005                      More: < - + > ____ Row 0001 of 0001
C Ord Elements          M Units    Avg-Rate  Proj-Chg  %Of-Tot Cost  S
C. C MBJ CPU-CHARGE    6.99999 U  4.16666 U  28.3333 U  100.000 35A. __ U B.
-
-
-
-
Totals                6.99999 U          28.3333 U
Enter  F5=<Per  F6=>Per  F7=Bkwd  F8=Fwd  F11=Generate
-----+-----
Command ==>
F1=Help  F3=Exit  F4=Prompt  F9=Command  F10=Action Bar  F12=Cancel
    
```

The next panel shows the **new** rates generated for the Rate Determination (Elements) Entry panel when you press **Enter**. Note that the Proj-Chg field displays a close approximation of the value you entered in the Cost column (see A. below).

#### New Rates for CPU-CHARGE

```

USERID          CA PMA Chargeback          MM/DD/YY HH:MM:SS
__ Acctdefs Cbdefs Query Data Period Options Exit Help
+-- CBORTEQ ----- Rate Determination Entry -----+
| Panel Exit Help |
|-----|
| Enter rate determination data. Then select an action or Enter. |
| Period : 005                      More: < - + > ____ Row 0001 of 0001 |
| C Ord Elements                    M Units   Avg-Rate Proj-Chg %Of-Tot Cost  S |
|   _ MBJ CPU-CHARGE                6.99999 U 5.14705 U 34.9999 U 100.000 _____ |

```

The next panel shows the **new** prorated values of the subordinate qualifiers for element CPU-CHARGE for period 5. Compare this panel to the one shown in Rate Determination (Qualifiers) Entry Panel.

**Prorated Values for Subordinate Qualifiers**

```

USERID          CA PMA Chargeback          MM/DD/YY HH:MM:SS
__ Acctdefs Cbdefs Query Data Period Options Exit Help
+-- CBORTEQ ----- Rate Determination Entry -----+
| Panel Exit Help |
|-----|
| Enter rate determination data for MBJ CPU-CHARGE . |
| Period : 005                      More: < - + > ____ Row 0001 of 0002 |
| C Qualifiers                      Mod Units   Rate   Proj-Chg %Of-Tot Cost  S |
| _ @DEFAULT                        3.00000 U 6.17646 U 18.5294 U 52.941 _____ |
| _ @SHIFT1                         3.99999 U 4.11764 U 16.4705 U 47.058 _____ |
| _                                     _____ |
| _                                     _____ |
| _                                     _____ |
| Totals                            6.99999 U          34.9999 U |
| Enter F5=Left F6=Right F7=Bkwd F8=Fwd |
+-----+
Command ==>
F1=Help F3=Exit F4=Prompt F9=Command F10=Action Bar F12=Cancel

```

## Copy MOD -> TAB

The Copy MOD to TAB panel allows you to copy the contents of the CCCMOD table to the CCCTAB table. This function should only be used if you used **copy** to create the CCCMOD table. The following confirmation panel appears. You **must** select either YES or NO.

**Caution** Selecting YES on the panel above **deletes** the information on the *live* CCCTAB table. Therefore, it should be used carefully.

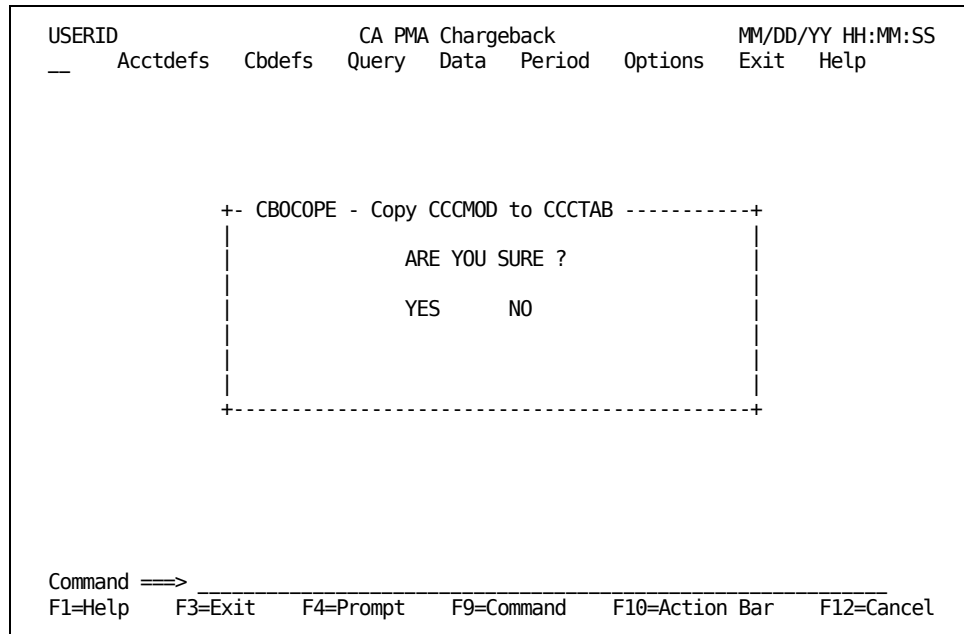

A description of the Copy CCCMOD to CCCTAB panel follows.

### Access

The Copy CCCMOD to CCCTAB panel appears when one of these events occurs:

- You choose Copy MOD -> TAB on the Period Functions pull-down.
- You type **PC** in the fast path area of the Primary Panel's action bar.

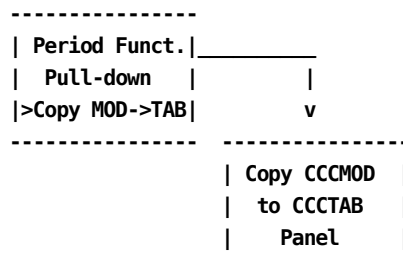





# Chapter 9: Setting CA PMA Chargeback Options

---

## Overview

The CA PMA Chargeback Options are executed when you select **Options** from the action bar on the Primary Panel. The following Options pull-down appears. You perform further selections by placing the cursor next to the function you want to perform and pressing Enter, or entering the mnemonic in the pull-down's entry field.

USERID	CA PMA Chargeback				MM/DD/YY HH:MM:SS			
__	Acctdefs	Cbdefs	Query	Data	Period	Options	Exit	Help
						Options		
						_ 1. User Settings		
						2. Versions		
						F12=Cancel		

Command ==> \_\_\_\_\_  
F1=Help F3=Exit F4=Prompt F9=Command F10=Action Bar F12=Cancel PA1=Susp

Next is a description of these choices.

**1. User Settings**

Used to assign the options you want in effect for your userid.

**2. Versions**

Used to specify the table version you want your input validated against.

**Note:** You indicate your selection by entering the number or mnemonic for the desired selection in the pull-down entry area and pressing Enter. You can also tab to action you want to perform and press Enter.

**1**

Takes you to the User Options panel in the next section.

**2**

Takes you to the Versions panel shown in Section Versions.

**Enter**

Takes you to the function where the cursor is placed.

## User Options Panel

This panel gives individual users the ability to change the default settings (for their userid) for the options listed.

```

USERID          CA PMA Chargeback          MM/DD/YY HH:MM:SS
__  Acctdefs  Cbdefs  Query  Data  Period  Options  Exit  Help
+-- CB0PTNS ----- User Options -----+
|                                     |
|      Panel  Exit  Help              |
|-----+-----+-----+-----+-----+
|                                     |
| Update options. Then Save.         |
|                                     |
| Warning Msgs . . . . YES           | Mnemonics . . . . YES
| Info Msgs   . . . . YES           | Action Bar . . . . NOREV
|                                     |
| Save/Delete Prompt . BOTH         | DataBase Depth . . 00500
| PF13-24 = PF1-12 . . YES         |
|                                     |
|      F5=Save                        |
+-----+-----+-----+-----+

Command ==> _____
F1=Help  F3=Exit  F4=Prompt  F9=Command  F10=Action Bar  F12=Cancel  PA1=Susp

```

A description of the Options panel follows.

### Access

The User Options panel appears when:

- You type OV in the fast path area of the Primary Panel's action bar.
- You select User Settings on the Options pull-down.

### Input

The User Options panel displays default values (specified in your profile). This panel lets you change them for your userid. Because you have the ability to change the information by typing over the displayed values, the following fields are considered input areas:

#### Warning Msgs

Default: YES. This entry field specifies whether or not *warning* messages display.

#### Mnemonics

Default: YES. This option allows you to remove the fast path entry fields by specifying Mnemonics. . . NO; thus, **removing** the fast path underscore display characters from the CA PMA Chargeback Primary Panel and action bar pull-downs. Therefore, all selections from the Primary Panel and pull-downs are performed by tabbing the cursor to the appropriate selection and pressing Enter.

USERID	CA PMA Chargeback						MM/DD/YY HH:MM:SS	
Acctdefs	Cbdefs	Query	Data	Period	Options	Exit	Help	
CB Definitions								
1. Charge Elements								

**Info Msgs**

Default: YES. This entry field specifies whether or not *informational* messages appear.

**Action Bar**

Default: NOREV. Use this option to indicate whether or not the Action Bar displays in reverse video (REV or NOREV).

**Save/Delete Prompt**

Default (BOTH). A four position entry field indicating whether or not the Save and Delete prompts display. Options include:

- SAVE Only the SAVE prompt is displayed
- DEL Only the DElete prompt is displayed
- BOTH Both the SAVE and DElete prompts are displayed
- OFF Suppresses save and delete messages.

**DataBase Depth**

Default: 500. A five position entry field defining the maximum number of records returned for a database access (used for online Query). A minimum of 10 rows is required.

**PF13-24 = PF1-12**

Default: Yes. This option allows you to assign function key settings 13-24 to be equivalent to settings 1-12.

**Action**

**F5**

**(Save)** Saves these options.

## The Are You Sure? Window

The SAVE/DELETE prompt on the User Options panel lets you tell the CA PMA Chargeback system whether or not you want the Save and Delete windows to appear during your online session.

The list below explains every valid value for the Save/Delete Prompt field. The default is BOTH. The value you specify determines whether or not the Delete prompt (also known as the **Are You Sure ?** window) displays.

### **SAVE**

Only the SAVE prompt is displayed.

### **DEL**

Only the DELeTe prompt is displayed.

### **BOTH**

Both the SAVE and DELeTe prompts are displayed.

### **OFF**

Suppresses save and delete messages.

To view **Are You Sure ?** windows during this session, select DEL or BOTH. Let's assume you kept the default value, BOTH. Whenever you attempt to delete fields or records, CA PMA Chargeback displays this window so you can cancel the delete if it was a mistake. To cancel a delete, tab to NO and press Enter. To authorize a delete, just press Enter.

**Note:** By default, the cursor is positioned at **Yes**.

## Versions

Throughout this guide, we have stressed the definition and the importance of the term **version**. It is critical when creating data that CA PMA Chargeback validates its definitions against the correct version of DataManager tables. The same holds true for performing queries.

The information displayed on this panel is obtained from the DataManager database table OPTTAB.

**Note:** You **cannot** change a version if other dialogs or panels are active.

```

USERID          CA PMA Chargeback          MM/DD/YY HH:MM:SS
--  Acctdefs  Cbdefs  Query  Data  Period  Options  Exit  Help
+-- CBOPTVE -- Versions -----+
|   Panel  Exit  Help              |
|-----|
|   Update options. Then Save.     |
|   DM / CB Version . . TEST ____ |
|   F5=Save                        |
+-----+

Command ==> _____
F1=Help  F3=Exit  F4=Prompt  F9=Command  F10=Action Bar  F12=Cancel  PA1=Susp
    
```

A description of the Options panel follows.

### Access

The Versions panel appears when:

- You type OV in the fast path area of the Primary Panel's action bar.
- You select Versions on the Options pull-down.

### Input

The Versions panel displays default values that you can change for your userid. Because you have the ability to change the information by typing over the displayed values, the following fields are considered input areas:

#### DM / CB Version

This field consists of two, four-character entry areas. The first area, **DM**, relates to the committed DataManager version used in validating CA PMA Chargeback entries. This entry **must** be either PROD or TEST.

The second four positions (5-8), **CB** define the CA PMA Chargeback version to be used when displaying data.

**Note:** When defining new entries, this value **must** be blank.

To view committed DataManager definitions, specify the four-character CA PMA Chargeback version used during commit processing. This gives you the full eight-character version.

**Action**

**F5**

**(Save)** Saves these options for your userid.

## Examples

### Example 1: Using the Versions Panel to Create a Construct

The following panel shows you how to enter Version options so that you can create CA PMA Chargeback constructs using the Accounting Structure, Accounting Sources, Accounting Sources Lookup, and Accounting Periods panels. These panels use only a four-character version. This version is equivalent to the DataManager version they are committed to.

```

USERID          CA PMA Chargeback          MM/DD/YY HH:MM:SS
--            +--- CBOPTVE -- Versions -----+
              Panel Exit Help
              -----+
              Update options. Then Save.
              DM / CB Version . . PROD ____
              F5=Save
              -----+

Command ==>
F1=Help  F3=Exit  F4=Prompt  F9=Command  F10=Action Bar  F12=Cancel  PA1=Susp
    
```

## Example 2: Using the Versions Panel to View Committed ChargeBack Definitions

The following panel specifies we want to view CA PMA Chargeback definitions for the CA PMA Chargeback PRODPROD version.

We specified:

- PROD as the committed DM version we want to use since PROD was the DM used when these definitions were committed.
- PROD for the CB version since this was the CB (CA PMA Chargeback version) used during commit processing.

```

USERID          CA PMA Chargeback          MM/DD/YY HH:MM:SS
--  Acctdefs  Cbdefs  Query  Data  Period  Options  Exit  Help
+-- CB0PTVE -- Versions -----+
|   Panel  Exit  Help              |
|-----|
| Update options. Then Save.      |
| DM / CB Version . . PROD PROD  |
| F5=Save                          |
+-----+

Command ==>
F1=Help  F3=Exit  F4=Prompt  F9=Command  F10=Action Bar  F12=Cancel  PA1 Susp
    
```

### Example 3: Using the Versions Panel to View/Update (Development) CA PMA Chargeback Definitions

The following panel shows how to specify you want to view CA PMA Chargeback **Development** (in process) definitions. Development definitions can be viewed and updated. Committed versions **cannot** be updated.

Using the sample panel below, specify:

- TEST as the committed DM version we want to use since TEST was the DM used when these definitions were committed.
- Leave the CB Version blank. Blanks indicate the Development version.

```

USERID          CA PMA Chargeback          MM/DD/YY HH:MM:SS
--  Acctdefs  Cbdefs  Query  Data  Period  Options  Exit  Help
+-- CBOPTVE -- Versions -----+
|   Panel  Exit  Help  |
|-----|
| Update options. Then Save. |
| DM / CB Version . . . TEST ____ |
|   F5=Save  |
+-----+

Command ==>
F1=Help  F3=Exit  F4=Prompt  F9=Command  F10=Action Bar  F12=Cancel  PA1=Susp
    
```



# Chapter 10: Using Help

---

All CA PMA applications provide you with an extensive Help facility that is available to you from the moment you log on to an application. This chapter:

- explains how to request help
- describes the About window
- summarizes what these help panels have in common
- describes the different types of help that are available
- tells you how to leave Help

## Requesting Help

You can request Help in the following ways:

To Get	Do This
Panel Help	Press F1 when a panel appears; make sure the cursor is <b>not</b> positioned on a field.
Field Help	Tab the cursor to the field you want specific information for and press F1.
Help pull-down	Select the Help option from an action bar.

To request Help from an action bar, tab the cursor to the **Help** keyword and press Enter. The following Help pull-down appears:

```
USERID                CA PMA Chargeback                MM/DD/YY HH:MM:SS
_  Acctdefs  Cbdefs  Query  Data  Period  Options  Exit  Help

A 1-character field that allows
you to make a selection using a
mnemonic that can be either a
number or the first letter of an
action.

You can also make your selection
by tabbing the cursor to the
action you want to perform and
pressing Enter.

Help
_ 1. Index
  2. Table of Contents
  3. Help for Help
  4. About
-----
F12=Cancel

Command ==> _____
F1=Help  F3=End  F4=Prompt  F9=Command  F10=Action Bar  F12=Cancel  PA1=Susp
```

An overview of Help pull-down choices is provided next.

**1. Index**

Displays a list of items, in alphabetical order, for which Help is available.

**2. Table of Contents**

Displays a list of topics for which Help is available.

**3. Help for Help**

Gives you information on how to use the Help system.

**4. About**

Displays a pop-up window telling you the **genlevel** of the CA PMA product you are using.

## The About Window

To verify the **genlevel** of the CA PMA product you are using, you must select the Help keyword from the **Primary Panel's** action bar and then select **About**. A pop-up window appears telling you the genlevel of your product.

The About window appears when you choose Help from an action bar. Then select **4. About** from the Help pull-down.

Press F3 to return to the last product panel that CA PMA Chargeback displayed.

# Help Panel Areas

## Overview

The following sample panel is the Help panel for the Input pull-down. The top line of the panel provides you with the following information:

**panelid:**

Displays the Help panelid. The panelid closely resembles the product panelid and always ends with the letter H.

**panel name:**

Tells you either the topic or the panel that is being discussed.

**HELP:**

Identifies the panel as a Help panel.

The bottom of the panel tells you the function key settings that are valid for the panel. A description of these settings is provided in the next section.

```
USERID                      CA PMA Chargeback                      MM/DD/YY HH:MM:SS
+-- CBONLNEH _ ----- PERIOD FUNCTIONS -----HELP +
|
| The Period Functions pull-down menu (CBONLNE) presents three
| items for your selection:
|
|   __ 1. Forecasting
|   __ 2. Rate Determination
|   __ 3. Copy MOD --> TAB
|
| Tab to the function you want and press ENTER.
| You will be taken to the first panel of the function you select.
|
|
| F1=Help  F2=Topic  F3=End  F5=Cont  F7=Prev  F8=Next  F9=Index|
+-----+
```

## Help Function Key Settings

Function key settings let you move efficiently through CA PMA Help facilities.

F1=Help	F2=Topic	F3=End	F5=Cont	F7=Prev	F8=Next	F9=Index
---------	----------	--------	---------	---------	---------	----------

### **F1=Help**

Displays the Help for Help panel.

### **F2=Topic**

Takes you to the Table of Contents.

### **F3=End**

Returns you to the resident product panel from which you called Help.

### **F5=Cont**

Takes you to the next logical panel (Field Help takes you to the Index; Topic Help takes you to the Table of Contents).

### **F7=Prev**

Takes you to the previously viewed panel.

### **F8=Next**

Takes you to the next *topic* discussed.

### **F9=Index**

Provides you with a list of entries for which Help is available.

## Moving Through Help

The following diagram gives you an overview of how you can access and move through the CA PMA Help facility, when you request Help from a product panel.

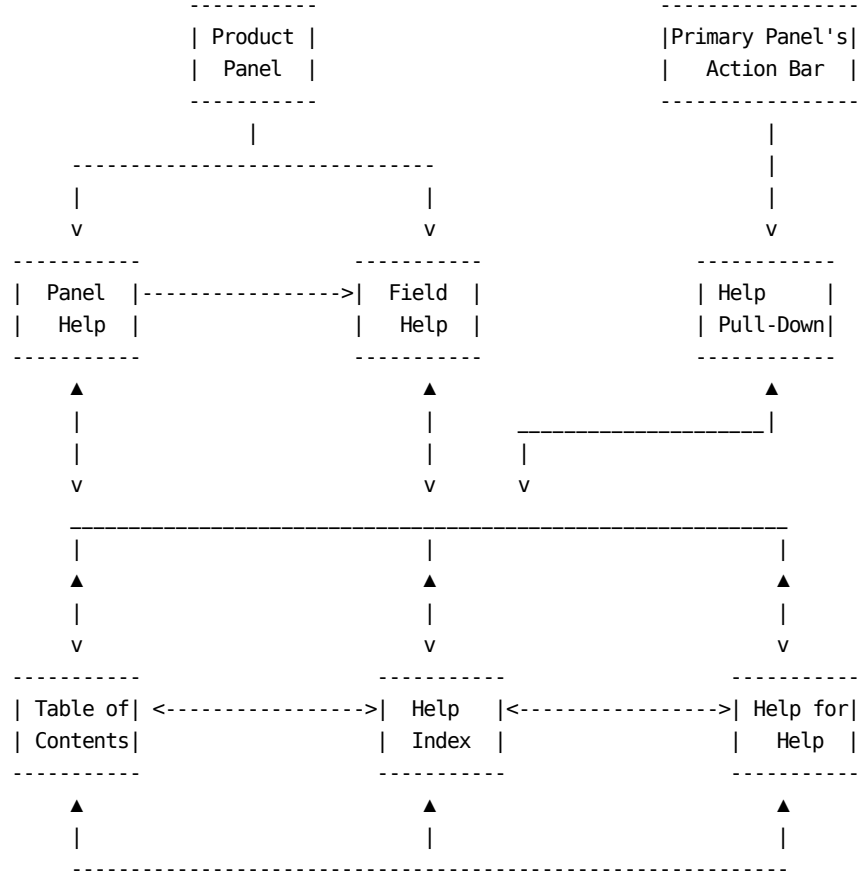

## Exiting Help

To exit the CA PMA Help facility, simply press F3.

# Help Panels

## Panel Help

Panel Help is available for every product panel. These Help panels also list fields from the product panel for which there is Help.

```

USERID                CA PMA Chargeback                MM/DD/YY HH:MM:SS
+-- CBOFACT0H _ ----- OVERALL FORECAST RESULTS ----- HELP -----+
|
| The Overall Forecast Results panel (CBOFACT0) graphically presents a
| view of the total charges for all elements for both forecasted and
| existing periods. Thus, records from the CCCMOD table and the CCCTAB
| table are joined in the Overall Forecast Results panel.
|
| The first value of the scale represents the smallest charge. The
| last value of the scale represents the largest charge plus ten
| percent.
|
| To view information on any of the panel items, select one of the
| following:
|
|   __ Charge          __ Prd          __ Amount          __ S (Scale)
|   __ Bkwd           __ Fwd          __ Elements
|
| F1=Help  F2=Topic  F3=End  F5=Cont  F7=Prev  F8=Next  F9=Index
+-----+

```

Panel Help appears when you press **F1** and the cursor is not positioned on a field.

These actions are available on all Help panels:

### **F1=Help**

Displays an explanation on how to use the Help facility.

### **F2=Topic**

Displays the Help Table of Contents.

### **F3=End**

Returns you to the resident product panel from which you called Help.

### **F5=Cont**

Takes you to the next logical panel.

### **F7=Prev**

Takes you to the previously viewed panel.

### **F8=Next**

Takes you to the next topic discussed.

**F9=Index**

Displays the Help Index.

## Field Help

Field Help contains information about a specific field on a product panel. It appears when you tab to a product panel's field you want Help with and press F1. You can also get Help with a field when it is listed as a selection on a Panel Help.

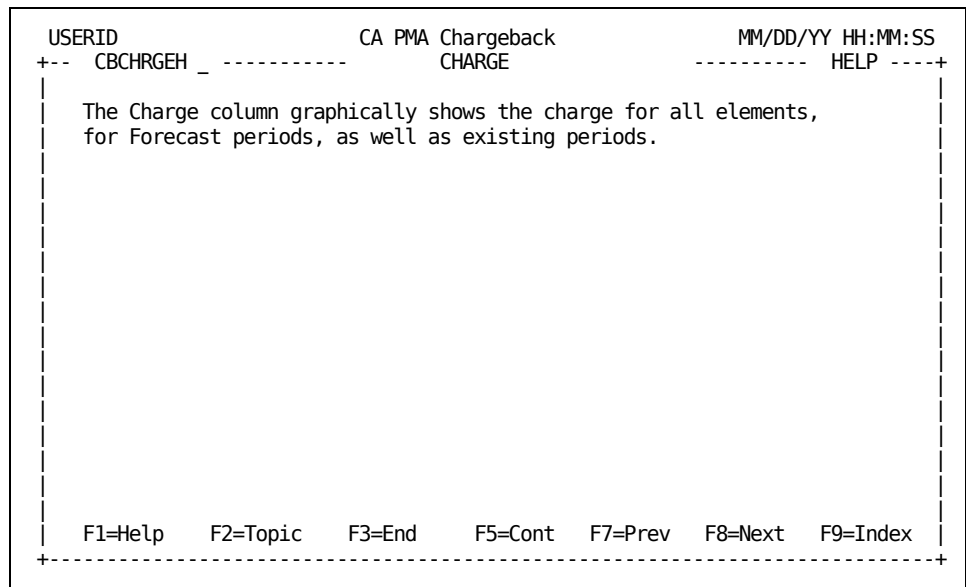

Field Help appears when one of the following events occurs:

- You press *F1* and the cursor is positioned on a field.
- You select a field listed on a panel help.

## The Table of Contents Panel

This panel displays a list of topics for which Help is available. Simply tab to the topic you are interested in viewing and press Enter. Topic panels, in turn, allow you to make further selections.

USERID	CA PMA Chargeback	MM/DD/YY HH:MM:SS
+-- CBTOPICH _ -----	TABLE OF CONTENTS (TOPICS) -----	HELP -----+
__ Account Definition (ACCTDEFS)		__ DATA
__ Accounting Structure		__ Budget
__ Accounting Sources		__ Debit/Credit
__ Period Tables		__ PERIOD
__ CBDEFS		__ Forecasting
__ Charge Elements		__ Rate Determination
__ Charge Units		__ Copy MOD --> TAB
__ Qualifiers		__ OPTIONS
__ Normalizers		__ User Settings
__ Modifiers		__ Versions
__ Split Job Charges		__ EXIT
__ Cost Recovery		__ HELP With HELP
__ Overhead Distribution		__ INDEX
__ QUERY		
__ Charge Query Selection		
__ Budget Query Selection		
__ DB/CR Query Specifications		
+-----+		
F1=Help	F2=Topic	F3=End
F5=Cont	F7=Prev	F8=Next
F9=Index		

Topic Help panels appear when one of the following events occurs:

- You select **2. Table of Contents** from the Help pull-down.
- You press the Topic function key on any Help panel.

## Topic Help Panel

A Topic panel appears when you make a selection on the Table of Contents panel. It provides you with an overview of the function you requested help for and with selections that take you to other panels containing more detailed information. The Next and Prev function keys take you to the next topic or previous Help panel.

```
USERID                CA PMA Chargeback                MM/DD/YY HH:MM:SS
+--- CBFCS TEH _ ----- Forecast Selection ----- HELP -----+
|
| The Forecast function allows you to view and optionally modify the
| contents of the CCCMOD table. The CCCMOD table is generated during
| batch forecasting. If no CCCMOD table exists, you will not be able
| to perform the online Forecast function until one is created.
|
| CA PMA Chargeback also verifies that the version specified in the
| CCCMOD table matches the version specified in the Primary panel's
| option function. Until the two versions match, you will not be
| able to perform the online Forecast function.
|
| For more information on any of the Forecasting function panels,
| select one of the following.
|
|   __ Overall Forecast Results       __ Forecast Elements List
|   __ Forecast Element               __ Forecast Qualifiers List
|   __ Forecast Qualifier             __ Forecast Primary
|   __ Period Specifications
|
| F1=Help  F2=Topic  F3=End  F5=Cont  F7=Prev  F8=Next  F9=Index
+-----+-----+-----+-----+-----+-----+-----+
```

Topic Help appears when one of the following events occurs:

- You press the **F8** Next function key on any Help panel.
- You press the **F2** Topic function key and select a topic from the Table of Contents panel.

## Index Help Panels

Index panels provide you with an alphabetical list of items for which Help is available. To make a selection, tab to the item you want information for and press Enter. This takes you to the Help panel that contains pertinent information.

USERID	CA PMA Chargeback	MM/DD/YY HH:MM:SS
+-- CBINDEXH -----	INDEX	HELP -----+
Tab to the item below and press ENTER or press CONTinue		
__ Account Definitions	__ Command	__ Lookup
__ Accounting Periods	__ Constant	__ Lop
__ Accounting Sources	__ Cost	__ Modifiers
__ Accounting Structure	__ Count	__ Max-Min Charge
__ Amount	__ Create	__ Normalizer
__ Arithmetic Operators	__ Credit Amount	__ Normalizer Entry
__ Average Rate	__ Debit Amount	__ Norm
__ Backward	__ Debit/Credit	__ Options
__ Break	__ Delete	__ ORD Type
__ Browse	__ Exit	__ Overhead
__ Budget	__ Expand	__ Panel
__ Budget Amount	__ Field Constant	__ Period
__ Budget Query	__ Forecasting	__ Qualifier
__ CBCDEFS	__ Forward	__ Rate
__ Charge	__ Function Keys	__ Record Count
__ Charge Element	__ Field Qualifier	__ Rop
__ Charge Unit	__ HELP with HELP	__ Save
+-----+		
F1=Help	F2=Topic	F3=Exit
F5=Cont	F7=Prev	F8=Next
F9=Index		

The Index Help panel appears when you press the Index function key on any Help panel.



# Chapter 11: Batch Processing & Reporting

---

## Overview

This chapter discusses DataManager and CA PMA Chargeback utilities, batch processing, and batch reporting with CA Earl.

The first part of the chapter describes the batch jobs (utilities) you must submit to:

- Copy a CA PMA Chargeback version
- Commit a live CA PMA Chargeback version
- Archive (Backup) tables
- Restore tables

The second part of this chapter discusses CA PMA Chargeback:

- Daily Processing
- Summary Processing
- Period Processing

The third part of the chapter describes CA PMA Chargeback reporting using CA Earl.

The following table summarizes the programs and program options used for batch processing, as well as associated PROCs and parameter files.

---

Program Name	What Does	C A I K S P A R	C A I K R P A R	PROC Name	SAMPJCL Member Name
CAKSARCH	Archives existing CA PMA Chargeback tables (BACKUP option)	X		CAKSARES	CAKRARCH
	Restores the backed up version of CA PMA Chargeback tables (RESTORE option)		X	CAKSARES	CAKREST
	Commits finalized CA PMA Chargeback definitions (COMMIT option)	X		CAKSARES	CAKRCOMT
	Copies CA PMA Chargeback production version of records into the DEVELOPMENT version for editing (COPY option)	X		CAKSARES	CAKRCPY

---

CAKRLOAD	Processes CA PMA Chargeback input data using committed definitions	X	X	None	CAKRLOAD
CAKRPCLS	Closes a CA PMA Chargeback period (PeriodB)	X	X	None	CAKRPCLS
CAKRPOPEN	Opens a CA PMA Chargeback previously closed period	X	X	None	CAKRPOPEN
CAKRBREC	Recovers and distributes charges to all nonmodified CCCTAB records for the requested periods		X	None	CAKRSUM
Earl	Creates CA PMA Chargeback Reconciliation reports	X		CAKSEARL	CAKRECON
	Creates CA PMA Chargeback Invoices	X		CAKSEARL	CAKRINVC
CAKRFCST	CA PMA Chargeback Forecasting	X		None	CAKRFCST

**Note:** The CAJRJCL library contains the SAMPJCL members referenced above and the CAJRPROC library contains the PROC members.

To run a SAMPJCL member that uses a PROC, customize the PROC and either add the PROC to the USER.PROCLIB or copy the PROC instream.

The online component and each of these batch jobs references a file called CAIKSPAR. This parameter file is discussed on the next page.

**Caution** It is recommended that **before** you make any changes to DataManager or CA PMA Chargeback tables using the online component, you make a backup using the Archive/Backup function of the Archive/Restore PROC.

## The Parameter Files

The CA PMA system requires two parameter files or sequential data sets to define information required for DataManager and CA PMA Chargeback online and batch processing. The CAIKSPAR file is used by DataManager and CA PMA Chargeback applications while the CAIKRPAR file is used only by the CA PMA Chargeback application. The parameter files are accessed via the online dialogs and batch processes by the following ddnames: CAIKSPAR and CAIKRPAR.

**Note:** Both of these files are allocated and customized during installation.

## CAIKSPAR Parameter File

The CAIKSPAR file provides DataManager and CA PMA Chargeback with specific information about the database system your installation uses, as well as defining the Company Name that appears on your reports.

This file also defines specific information required by DataManager for batch processing and DataManager processing, as well as specific keywords used by DataManager

**Note:** The order in which you specify CAIKSPAR parameters is **unimportant**. You can abbreviate each keyword using the fewest characters that make it unique.

## Database-Related Keywords

The following four parameters are used to specify the database product your installation uses. CA PMA Chargeback supports CA Datacom and IBM's DATABASE2. Note that DATABASE\_NAME is defined during installation and that the following values are defaults. Use the table below as a guide in specifying the following parameters:

Parameter	DATABASE2	CA Datacom
DATABASE_NAME =	PMACB	CBASEPMA
PLAN_ID =	_____	N/A
SQL_TYPE =	DB2	Datacom
SUBSYSTEM_ID =	DB23	executing userid

### DATABASE\_NAME =

This parameter tells CA PMA Chargeback which database to use **for documentation purposes only**. Up to eight characters are permitted.

### PLAN\_ID =

This is a DB2 1-8 character parameter which is site dependent.

- If you are using DB2 and require the PLAN\_ID, **uncomment** the PLAN\_ID and enter the 1-8 character PLAN\_ID.
- If you are using DB2, but do not use the PLAN\_ID, the PLAN\_ID **must** remain as a comment.
- If you are using Datacom, the PLAN\_ID **must** remain as a comment.

### SQL\_TYPE =

This parameter tells CA PMA Chargeback the type of SQL statements that will be used.

### SUBSYSTEM\_ID =

This 1-4 character SSID or driver is used when DB2 links to data. For CA Datacom, the SUBSYSTEM\_ID should be any executing userid.

## Keywords Used by DataManager and CA PMA Chargeback

The following keywords are used for DataManager batch processing and CA PMA Chargeback online functions (options).

### **CUSTOMER\_NAME =**

The company name (up to 25 characters) you want to appear on your invoices and reports.

### **BASE\_VERSION = (required)**

This four character required field must be either TEST or PROD. It specifies the DataManager version that CA PMA Chargeback validates its online data against. For example: BASE\_VERSION = TEST

## CA PMA Chargeback Related Keywords

The following three parameters control CA PMA Chargeback decimal precision. Precision affects calculations, as well as the populating of the database. Therefore, its effect is system wide.

With the exception of Budget, Debit/Credit, and Query calculations and value display which are **fixed** at five decimal places, you can define up to 15 (significant digits and decimals). CA PMA Chargeback's default is 9999999999V99999 (10 digits followed by five decimal places).

### **CHARGE\_PREC =**

Specifies the precision: the number of decimal places used in the calculation and display of charges. Default: five decimal places.

### **RATE\_PREC =**

Specifies the precision: the number of decimal places used in the calculation and display of rates. Default: five decimal places.

### **UNIT\_PREC =**

Specifies the precision: the number of decimal places used in the calculation and display of units. Default: five decimal places.

**Note:** We do **not** recommend using more than five decimal places. Using more than five decimal places can result in data overflow with significant digits being lost.

## CAIKSPAR Usage Considerations

### Using more than one CAIKSPAR file

You may want to have two CAIKSPAR files. One for production and a second file that you can change as required.

Caution: Precision definitions should be defined only **once** -- during implementation. They should then remain **static**.

### Precision:

Do **not** change precision values after CA PMA Chargeback is installed. **You will invalidate all CA PMA Chargeback data and definitions.** If you do change precision values, you have to clear the CA PMA Chargeback data tables.

The following are the recommended precisions for the previously discussed parameters:

```
CHARGE_PREC = 5
RATE_PREC = 5
UNIT = 5
```

## CAIKRPAR Parameter File

The CA PMA Chargeback parameter file (CAIKRPAR) defines the specific control information required for batch processing. Some of its keywords are used by all batch job streams while others are only specific to the load process (CAKRLoad). This data set is allocated and customized during installation.

**Note:** You can abbreviate each keyword using the fewest characters that make it unique.

## CAIKRPAR Keywords Used by All CA PMA Chargeback Batch Processes

### BASE\_VERSION:

This parameter defines the **first four characters** of the CA PMA Chargeback version tables that will be used (either PROD or TEST) for processing.

### CBLOAD\_VERSION =

This parameter specifies the **second four characters** of the CA PMA Chargeback version used for processing. CBLOAD version names are user-defined, the following list is provided as an example:

```
CBLOAD_VERSION = TEST CBLOAD_VERSION = PROD CBLOAD_VERSION = WXYZ
```

### Usage Considerations:

Only **committed** versions can be specified.

## Daily CA PMA Chargeback Processing (CAKRLOAD) Keywords

### RECONCILIATION\_FILE =

This parameter is used to create an **optional** reconciliation file composed of variable length records. This file can consume a significant amount of disk space. The Reconciliation file shows in **detail** all charges for every ORD. RECON = N is the default.

The records in this file are formatted as follows:

```
|DESCRIPT |ORD|Segment|Segment|Segment|...|Segment|
|_____|_|_____|_____|_____|_____|_____|
```

#### Usage Considerations:

- If RECON = Y, you **must** provide a DD name of CAIKRREC in the CAKRLOAD JCL.
- RECON = is considered the equivalent of NO. Make sure you remove or comment out the CAIKRREC DD statement in the CAKRLOAD JCL.
- If RECON = N, make sure you **remove** or comment out the CAKIRREC DD statement in the CAKRLOAD JCL.

### PERIOD\_VERSION =

This **optional** parameter allows you to specify a CBLOAD Version that is associated with a period. (If you use the PERIOD\_VERSION = parameter you must have at least one period defined. You can use up to four characters to specify a period.) The following example shows you how to specify period 2 for CBLOAD version TEST:

```

Start
Period
| End
| Period
| | CBLOAD
| | Version
| | |
v v v
PERIOD_VERSION = 2 2 TEST
```

#### Usage Considerations:

- You can omit leading zeros when specifying period versions.
- You can have multiple period versions, as shown below. However, periods **cannot** overlap.

```

PERIOD_VERSION = 101 120 PROD
PERIOD_VERSION = 121 130 TEST
PERIOD_VERSION = 141 150 WXYZ
```

- It is strongly recommended that once a period is closed, you delete the specification in order to save memory usage in the batch run.

- If you do not specify the PERIOD\_VERSION parameter, the four-character CB\_VERSION is used as the PERIOD\_VERSION. In this case, the application version prints on the CAKRLOAD Summary Report, shown on page CAKRLOAD Processing Summary Report as CB\_VERSION (default). When this is the case, both starting and ending periods are reported as 0. Therefore, it is recommended you use the PERIOD\_VERSION parameter.

## Examples

- In the following example, we have overlapping periods (1-5 and 5-10).

```
BASE = PROD
RECON = N
CBLOAD = ABCD
PERIOD_VER = 1 5 EFGH      } This will give you an error
PERIOD_VER = 5 10 IJKL     } message and program will
PERIOD_VER = 11 20 WXYZ      halt
```

- In the following example, we did not specify a PERIOD-VERSION, and CA PMA Chargeback defaults to the CBLOAD version. In this case ABCD:

**Note:** If you do not specify a CBLOAD version, records are not billed.

```
BASE = PROD
RECON = N
CBLOAD = ABCD
```

- If you do not specify a CBLOAD = parameter, using the following example, CA PMA Chargeback does not calculate charges for periods greater than 20.

```
BASE = PROD
RECON = N
PERIOD_VER = 1 5 EFGH
PERIOD_VER = 6 10 IJKL
PERIOD_VER = 11 20 WXYZ
```

- In this example we want to bill for period 21. However, version defaults to PRODABCD.

```
BASE = PROD
RECON = N
CBLOAD = ABCD
PERIOD_VER = 1 5 EFGH
PERIOD_VER = 6 10 IJKL
PERIOD_VER = 11 20 WXYZ
```

## The Archive/Restore Program (CAKSARCH)

The CAKSARCH program is a multi-purpose program that performs specific CA PMA table maintenance functions, depending on the program option specified. The options include:

- Archiving or backing up definition and/or data tables (BACKUP option)
- Restoring definition and/or data tables (RESTORE option)
- Committing the Development version of CA PMA definition tables so that these definitions can be used in processing (COMMIT option)
- Copying committed definition tables to the Development version so that modifications can be made via the online facility (COPY option)

**Note:** All maintenance functions can be performed within a **single** execution of the program. When multiple options are executed in this manner, table maintenance control statements are executed in the order they are specified.

The Archive/Restore program's sole purpose is to archive specific tables used in CA PMA processing. It is **not** intended to replace full database backups or restores.

The next page contains a sample of the CAKSARES PROC, followed by a discussion of each program option.

If you use the CAKSARES PROC, you **must** customize it and either copy it to your system or user PROCLIB, or use it instream within each of the JCL members. Refer to the table on page Overview for a listing of JCL members.

## CAKSARES Procedure

```

//*****
//* CAKSARES ARCHIVE/RESTORE PROC
//*
//* THIS PROC IS USED DURING:
//*
//* 1. ARCHIVING (BACKUP) OF TABLES
//* 2. RESTORING OF ARCHIVED TABLES
//* 3. COMMIT PROCESSING
//* 4. COPY PROCESSING
//*
//* REFER TO FOLLOWING SAMPJCL MEMBERS FOR DETAILS:
//*
//* 1. CAKSARCH - DM ARCHIVE
//* 2. CAKSREST - DM RESTORE
//* 3. CAKSCOMT - DM COMMIT
//* 4. CAKSCPY - DM COPY TABLES
//* 5. CAKRARCH - CA PMA Chargeback ARCHIVE
//* 6. CAKREST - CA PMA Chargeback RESTORE
//* 7. CAKRCOMT - CA PMA Chargeback COMMIT
//* 8. CAKRCPY - CA PMA Chargeback COPY TABLES
//*
//* ** IF YOUR DATABASE IS DB2, REMOVE THE Datacom LIBRARIES AND **
//* ** THE DCIND SYMBOLIC, AND UNCOMMENT THE DB2 LIBRARY. **
//*
//*****
//CAKSARES PROC INDEX='CAI', /* DATA SET HIGH LEVEL QUALIFIER
//          DCIND='CAI', /* Datacom HIGH LEVEL QUALIFIER
//          SYSOUT='*' /* SYSOUT CLASS
//*
//STEP010 EXEC PGM=CAKSARCH
//STEPLIB DD DSN=&INDEX..CAJRLOAD,DISP=SHR
//          DD DSN=&INDEX..CAICICS,DISP=SHR
//          DD DSN=&DCIND..USERLOAD,DISP=SHR <-- Datacom LIBRARY
//          DD DSN=&DCIND..INFOCAI.LOAD,DISP=SHR <-- Datacom LIBRARY
//          DD DSN=&DCIND..LOAD,DISP=SHR <-- Datacom LIBRARY
//*          DD DSN=SYS2.DSNLOAD,DISP=SHR <-- DB2 LIBRARY
//CAIKSPAR DD DSN=&INDEX..CAIKSPAR,DISP=SHR
//CAIKRPAR DD DSN=&INDEX..CAIKRPAR,DISP=SHR
//SYSPRINT DD SYSOUT=&SYSOUT.
//SYSUDUMP DD SYSOUT=&SYSOUT.
//SYSIN DD DDNAME=SYSIN

```

## The BACKUP Option

Archiving/Backup of CA PMA Chargeback tables is performed using the BACKUP option of the CAKSARCH program described below.

**BACKUP TBL=tableid,DD=ddname[,where\_clause;]**

**where:**

**TBL=**

The name of the table to be backed up. For example, CAI.PERTAB, or PMA.QUALTAB. All versions stored in each table are backed up.

**DD=**

References the JCL ddname that is used. This must be unique for each table BACKUP statement. A corresponding DD statement must also be defined.

**where\_clause (optional)**

It is recommended that you always backup an entire table, which means you would not use a WHERE clause. However, if used, the WHERE clause **must** end with a semicolon (;). WHERE clauses can be continued using spaces and commas.

- If a where\_clause is used, CA PMA Chargeback backs up the records that meet the where\_clause's selection criteria.
- If a where\_clause is omitted, CA PMA Chargeback backs up **all** records stored in the specified table.

## Rules

- Never use a where\_clause to backup data tables. If you use a where\_clause, not all the data in that table will be backed up.
- Never archive tables by their synonym name. **Always** specify the fully qualified table name or you will not be able to properly restore the tables.

## Examples

To backup the ACCSTTAB (Accounting Structures table), code the BACKUP control statement as shown below:

```
BACKUP TBL=CAI.ACCSTTAB,DD=BACKTAB1
```

where CAI is the table owner.

## BACKUP Option JCL (CAKRARCH)

```
//CAKRARCH JOB (ACCTINFO), 'PMGR', CLASS=A, REGION=4M, MSGCLASS=X
//*****
//* USE THIS JCL TO ARCHIVE CA PMA Chargeback TABLES
//*
//* INSTRUCTIONS:
//* 1. THIS JCL USES THE CAKSARES PROC
//*    PROVIDED IN THE SAMPJCL. EITHER COPY
//*    THE PROC TO THIS JCL OR ADD TO YOUR
//*    SYSTEM USER PROCLIB.
//* 2. MODIFY THE JOB CARD ACCORDING TO
//*    YOUR INSTALLATION STANDARDS.
//* 3. CHANGE THE HIGH LEVEL QUALIFIERS TO
//*    REFLECT THE CORRECT VALUES.
//* 4. MODIFY THE STEP010.SYSIN CONTROL
//*    STATEMENTS TO REFLECT THE TABLE(S)
//*    WHICH ARE TO BE ARCHIVED OR BACKED
//*    UP. BE SURE THAT A UNIQUE DD NAME IS
//*    INDICATED ON EACH STATEMENT.
//* 5. FOR EACH DD NAME THAT HAD BEEN
//*    DEFINED FOR STEP010.SYSIN, BE SURE
//*    THAT COMPARABLE DD STATEMENTS ARE
//*    DEFINED.
//*****
//*
//BACKUP EXEC PROC=CAKSARES,
//          INDEX='CAI',
//          DCIND='CAI',
//          SYSOUT='*'
//*
//*****
//* THE CONTROL STATEMENTS ARE PASSED TO THE
//* CAKSARES PROC BY THE STEP010.SYSIN DD.
//* MODIFY AS OUTLINED IN STEP 5.
//*****
//*
//STEP010.SYSIN DD *
  BACKUP TBL=CAI.ACSTTAB,DD=BACKTAB1
  BACKUP TBL=CAI.ACSTRTAB,DD=BACKTAB2
  BACKUP TBL=CAI.ACCTLOOK,DD=BACKTAB3
  BACKUP TBL=CAI.PERTAB,DD=BACKTAB4
  BACKUP TBL=CAI.CHOPTAB,DD=BACKTAB5
  BACKUP TBL=CAI.ELEMTAB,DD=BACKTAB6
  BACKUP TBL=CAI.NORMTAB,DD=BACKTAB7
  BACKUP TBL=CAI.QUALTAB,DD=BACKTAB8
  BACKUP TBL=CAI.RATETAB,DD=BACKTAB9
  BACKUP TBL=CAI.SPLITTAB,DD=BACKTAB10
  BACKUP TBL=CAI.SUMTAB,DD=BACKTAB11
  BACKUP TBL=CAI.UNITTAB,DD=BACKTAB12
```

```
//*  
  
//*****  
//* ADD THE APPROPRIATE NUMBER OF DD STATEMENTS  
//*****  
//*  
//BACKTAB1 DD DSN=&INDEX . .ACCSSTAB .ARCH,DISP=(NEW,CATLG,DELETE),  
//          DCB=(DSORG=PS,RECFM=VB,LRECL=4096,BLKSIZE=9192),  
//          UNIT=DISK,SPACE=(TRK,(10,)),VOL=SER=DSKVOL  
//BACKTAB2 DD DSN=&INDEX . .ACCSRTAB .ARCH,DISP=(NEW,CATLG,DELETE),  
//          DCB=(DSORG=PS,RECFM=VB,LRECL=4096,BLKSIZE=9192),  
//          UNIT=DISK,SPACE=(TRK,(10,)),VOL=SER=DSKVOL  
//BACKTAB3 DD DSN=&INDEX . .ACCTLOOK .ARCH,DISP=(NEW,CATLG,DELETE),  
//          DCB=(DSORG=PS,RECFM=VB,LRECL=4096,BLKSIZE=9192),  
//          UNIT=DISK,SPACE=(TRK,(10,)),VOL=SER=DSKVOL  
//BACKTAB4 DD DSN=&INDEX . .PERTAB .ARCH,DISP=(NEW,CATLG,DELETE),  
//          DCB=(DSORG=PS,RECFM=VB,LRECL=4096,BLKSIZE=9192),  
//          UNIT=DISK,SPACE=(TRK,(10,)),VOL=SER=DSKVOL  
//BACKTAB5 DD DSN=&INDEX . .CHOPTAB .ARCH,DISP=(NEW,CATLG,DELETE),  
//          DCB=(DSORG=PS,RECFM=VB,LRECL=4096,BLKSIZE=9192),  
//          UNIT=DISK,SPACE=(TRK,(10,)),VOL=SER=DSKVOL  
//BACKTAB6 DD DSN=&INDEX . .ELEMENTAB .ARCH,DISP=(NEW,CATLG,DELETE),  
//          DCB=(DSORG=PS,RECFM=VB,LRECL=4096,BLKSIZE=9192),  
//          UNIT=DISK,SPACE=(TRK,(10,)),VOL=SER=DSKVOL  
//BACKTAB7 DD DSN=&INDEX . .NORMTAB .ARCH,DISP=(NEW,CATLG,DELETE),  
//          DCB=(DSORG=PS,RECFM=VB,LRECL=4096,BLKSIZE=9192),  
//          UNIT=DISK,SPACE=(TRK,(10,)),VOL=SER=DSKVOL  
//BACKTAB8 DD DSN=&INDEX . .QUALTAB .ARCH,DISP=(NEW,CATLG,DELETE),  
//          DCB=(DSORG=PS,RECFM=VB,LRECL=4096,BLKSIZE=9192),  
//          UNIT=DISK,SPACE=(TRK,(10,)),VOL=SER=DSKVOL  
//BACKTAB9 DD DSN=&INDEX . .RATETAB .ARCH,DISP=(NEW,CATLG,DELETE),  
//          DCB=(DSORG=PS,RECFM=VB,LRECL=4096,BLKSIZE=9192),  
//          UNIT=DISK,SPACE=(TRK,(10,)),VOL=SER=DSKVOL  
//BACKTABA DD DSN=&INDEX . .SPLITAB .ARCH,DISP=(NEW,CATLG,DELETE),  
//          DCB=(DSORG=PS,RECFM=VB,LRECL=4096,BLKSIZE=9192),  
//          UNIT=DISK,SPACE=(TRK,(10,)),VOL=SER=DSKVOL  
//BACKTABB DD DSN=&INDEX . .SUMTAB .ARCH,DISP=(NEW,CATLG,DELETE),  
//          DCB=(DSORG=PS,RECFM=VB,LRECL=4096,BLKSIZE=9192),  
//          UNIT=DISK,SPACE=(TRK,(10,)),VOL=SER=DSKVOL  
//BACKTABC DD DSN=&INDEX . .UNITTAB .ARCH,DISP=(NEW,CATLG,DELETE),  
//          DCB=(DSORG=PS,RECFM=VB,LRECL=4096,BLKSIZE=9192),  
//          UNIT=DISK,SPACE=(TRK,(10,)),VOL=SER=DSKVOL
```

## BACKUP Option Output

Upon completion of the CAKSARCH program, you receive printed output that looks like this:

```
CA                - Q  ARCHIVE/RESTORE PROGRAM                PAGE  1
CA PMA/DM 1.0 9010KS100          REPORT          FRI JAN 25 16:32:27 1991
                USING: DATABASE=, SUBSYS=DB23, WHATSQL=DB2

                A.                B.

INPUT:
BACKUP TBL=QAHRDN1.ACCSTTAB,DD=BACKTAB1

SQL: SELECT * FROM QAHRDN1.ACCSTTAB
CAKS639I - NUMBER OF ROWS PROCESSED=2
CAKS607I - BACKUP PROCESSING COMPLETED SUCCESSFULLY
```

**A.**

SUBSYS=DB23:

This parameter is defined in the CA PMA Chargeback CAIKSPAR parameter file and provides your database's SUBSYSTEM\_ID. This example uses DATABASE2 - DB23.

**B.**

WHATSQL=DB2:

This parameter is defined in the CA PMA Chargeback CAIKSPAR parameter file and identifies the type of SQL you are using: either DB2 or CA Datacom. This example uses DB2.

## The RESTORE Option

**Caution** If you run backups using a `where_clause`, be extremely careful when restoring tables. The contents of the designated table are deleted before processing, and only archived records are restored.

Restoration of CA PMA Chargeback tables is performed using the RESTORE option of the CAKSARCH program described below.

```
RESTORE [TBL=qualifier.tablename,] DD=ddname, [,INS]
```

**where:**

**TBL= (optional)**

Tells CA PMA Chargeback which table to restore. If omitted, the table named in the BACKUP statement (from the run that created the backup) is used.

**DD=**

Specifies the ddname of the backup dataset. The information from this dataset is copied into the TBL file specified in the RESTORE control statement.

**INS (optional)**

If specified, CAKREST output lists the INSERT statements processed during this run. Omit INS to suppress this printed output.

## Rules

You should **not** restore a table that has been backed up by its synonym name.

## Examples

The following example shows you how code a control statement for the ELEM TAB table.

```
RESTORE TBL=userid.ELEMTAB,DD=BACKTAB
```

Remember, you **must** have a statement for each table that is to be restored.

## RESTORE Option JCL (CAKREST)

```
//CAKREST JOB (ACCTINFO), 'PMGR', CLASS=B, MSGCLASS=X, REGION=4M
//*****
//* PURPOSE: RESTORE CA PMA Chargeback TABLES.
//*
//* MODIFICATIONS:
//*
//* 1. THIS JCL USES THE CAKSARES PROC PROVIDED IN THE SAMPJCL.
//* EITHER COPY THE PROC TO THIS JCL OR ADD TO YOUR SYSTEM
//* USER.PROCLIB.
//* 2. MODIFY THE JOB CARD ACCORDING TO YOUR INSTALLATION STANDARDS.
//* 3. CHANGE THE LAST PARAMETER OF THE PARM STATEMENT ON THE EXEC
//* STATEMENT TO REFLECT THE APPROPRIATE DATABASE TO BE RESTORED
//* TO. IF NOT DEFINED, THE JOB DEFAULTS TO THE CURRENT DATABASE.
//* 4. CHANGE THE HIGH LEVEL QUALIFIERS TO REFLECT THE CORRECT
//* VALUES.
//* 5. MODIFY THE STEP010.SYSIN DD STATEMENT TO REFLECT THE TABLE(S)
//* THAT YOU WANT TO RESTORE.
//* 6. FOR EACH DD NAME THAT IS DEFINED TO THE STEP010.SYSIN, BE
//* SURE THAT COMPARABLE DD STATEMENT(S) HAVE ALSO BEEN DEFINED.
//*****
//*
//*****
//* IF THE TABLE IS TO BE RESTORED TO ANOTHER DATABASE, BE SURE TO
//* CHANGE THE PARM NAME ON THE EXECUTE STATEMENT.
//*****
//*
//RESTORE EXEC PROC=CAKSARES, PARM='AUTOCOMMIT,,PMA490', <-- CUSTOMIZE PARM
//          INDEX='CAI', <-- CUSTOMIZE
//          DCIND='CAI', <-- CUSTOMIZE
//          SYSOUT='*' <-- CUSTOMIZE
//*
//*****
//* A RESTORE STATEMENT MUST BE PRESENT FOR
//* EACH TABLE TO RESTORED.
//*****
//*
//STEP010.SYSIN DD *
RESTORE TBL=USERID.ELEMTAB, DD=BACKTAB
//*
//*****
//* ADD THE APPROPRIATE NUMBER OF DD STATEMENTS
//*****
//*
//BACKTAB DD DSN=&INDEX..ELEMTAB.ARCH, DISP=SHR <-- CUSTOMIZE
```

## RESTORE Option Output

When the Archive/Restore program successfully restores your tables, you receive printed output that looks like this:

```

CA                - Q  ARCHIVE/RESTORE PROGRAM                PAGE  1
CA PMA/DM 1.0 9010KS100          REPORT          FRI JAN 25 16:58:41 1991
                USING: DATABASE=DSNDB04, SUBSYS=DB23, WHATSQL=DB2

                A.                B.                C.

INPUT:
RESTORE TBL=QAHRDN1.ELEMTAB,DD=BACKTAB

FILE HEADER LINE=** TABLE=QAHRDN1.ELEMTAB COLS=9 on 1/18/1991 4:33:49 PM

SQL:
CREATE TABLE QAHRDN1.SHIRL
(VERSION CHAR(8),
ORDID CHAR(3),
ELEMENT CHAR(16),
UNIT CHAR(16),
NORMAL CHAR(16),
DEFRATE DECIMAL(15,0),
MINCHG DECIMAL(15,0),
MAXCHG DECIMAL(15,0),
COST DECIMAL(15,0)) IN DATABASE DSNDB04

CAKS632I - TOTAL NUMBER OF ROWS PROCESSED=8
CAKS611I - RESTORE PROCESSING COMPLETED SUCCESSFULLY

```

### A.

DATABASE=DSNDB04:

This parameter is defined in CA PMA Chargeback CAIKSPAR parameter file and identifies the database you want information restored to. In this example, the database is DSNDB04.

### B.

SUBSYS=DB23:

This parameter is defined in CA PMA Chargeback CAIKSPAR parameter file and provides your database's SUBSYSTEM\_ID. This example uses DATABASE2 - DB23.

### C.

WHATSQL=DB2:

This parameter is defined in CA PMA Chargeback CAIKSPAR parameter file and identifies the type of SQL you are using: either DB2 or Datacom. This example uses DB2.

## The COMMIT Option

Committing of CA PMA Chargeback tables is completed by executing the Archive/Restore program (CAKSARCH) using the COMMIT control statement described on the next page.

Modification of CA PMA Chargeback definitions is accomplished by editing the Development version of the definition tables via its Online facility. The Development version of definition tables are **not available** for processing until they are committed or frozen.

The commit process performs the following functions:

- Freezes all of the associated CA PMA products (product code, *pc*) development version definition tables.
- Deletes any existing CA PMA committed tables for the specified CA PMA Chargeback product and version. (Defined as the four-character *fromver* **plus** the four-character *tover* on the COMMIT control statement.)
- Changes the version of the CA PMA Chargeback development definitions, specified in the COMMIT control statement **plus** four blanks to an eight-character CA PMA Chargeback version (the four-character *fromver* plus *tover* specified in the COMMIT control statement).

For more information about *version*, see Section CA PMA Chargeback Terms & Related Concepts.

## The COMMIT Control Statement

The following control statement is used to commit a CA PMA Chargeback version whose first four characters must be TEST or PROD to a user-defined version.

```
          -->DM version
          |
COMMIT pc fromver tover
          |
          -- CB version
```

**where:**

**PC**

The two-character identifier of the CA PMA product for which commit will be performed. Use **CB** for CA PMA Chargeback.

**fromver**

The four-character identifier of the CA PMA Chargeback Development version that will be committed. This value is either TEST or PROD.

**tover**

A four-character identifier defining the second four characters of the CA PMA Chargeback version. The first four characters are taken from the value specified in the *fromver*.

## Examples

The following example shows you how to commit a CA PMA Chargeback Development definition currently existing as TEST to TESTWXYZ.

```

        ---> TARGET (tover)
        | (second four characters
        | of CA PMA Chargeback version)
        | The value indicated on the
        | fromver is assumed
        |
        FROM <-- |
        (fromver)| |
        COMMIT CB TEST WXYZ
        |
        -->PMA product code CB for CA PMA Chargeback
    
```

The diagram on the next page shows you how different CA PMA Chargeback definition tables are referenced before and after Commit processing.

The following diagram shows you how different CA PMA Chargeback definition tables are referenced before and after Commit processing.

	Before Commit	After Commit
<b>Table</b>	<b>Version</b>	<b>Version</b>
ACCSRTAB	bbbb	TEST
ACCSSTAB	bbbb	TEST
ACCTLOOK	bbbb	TEST
PERTAB	bbbb	TEST

	Before Commit	After Commit
<b>Table</b>	<b>Version</b>	<b>Version</b>
CHOPTAB	TESTbbbb	TESTWXYZ
ELEMTAB	TESTbbbb	TESTWXYZ
MODTAB	TESTbbbb	TESTWXYZ
NORMTAB	TESTbbbb	TESTWXYZ
QUALTAB	TESTbbbb	TESTWXYZ

QUERYTAB	TESTbbbb	TESTWXYZ
RATETAB	TESTbbbb	TESTWXYZ
SPLITTAB	TESTbbbb	TESTWXYZ
SUMTAB	TESTbbbb	TESTWXYZ
UNITTAB	TESTbbbb	TESTWXYZ

## Processing Considerations

- The corresponding DataManager version must be committed **prior** to processing the CA PMA Chargeback commit.
- Commit processing requires that there be a Development (FROMVER) version available. The correct sequence is::
  - Copy to the Development version
  - Make changes
  - Commit the Development version.

**Note:** Existing CA PMA Chargeback tables for the specified version will always be deleted during the commit process. If there is no Development version available, after commit processing, there will be no committed version: the old committed version is deleted.

## COMMIT Option JCL (CAKRCOMT)

```
//CAKRCOMT JOB (ACCTINFO), 'PMGR', CLASS=B, REGION=4M, MSGCLASS=X
//*****
//* USE THIS JCL TO COMMIT
//* CA PMA Chargeback TABLES
//*
//* INSTRUCTIONS:
//* 1. THIS JCL USES THE CAKSARES PROC
//*    PROVIDED IN THE SAMPJCL. EITHER COPY
//*    THE PROC TO THIS JCL OR ADD TO YOUR
//*    SYSTEM USER PROCLIB.
//* 2. MODIFY THE JOB CARD ACCORDING TO
//*    YOUR INSTALLATION'S STANDARDS.
//* 3. CHANGE THE HIGH LEVEL QUALIFIERS TO
//*    REFLECT THE CORRECT VALUES.
//* 4. MODIFY THE STEP010.SYSIN CONTROL
//*    STATEMENTS TO REFLECT THE APPROPRIATE
//*    PARAMETERS FOR PROCESSING.
//*****
//COMMIT EXEC CAKSARES,
//      INDEX='CAI',
//      DCIND='CAI',
//      SYSOUT='*'
//*****
//* BE SURE TO CHANGE THE COMMIT STATEMENT TO
//* REFLECT THE APPROPRIATE VERSION TO BE
//* COMMITTED.
//*****
//*
//STEP010.SYSIN DD *
COMMIT CB TEST XXXX
```

## COMMIT Option Output

When the Archive/Restore program successfully commits your tables, you receive printed output that looks like this:

```

CA                - Q  ARCHIVE/RESTORE PROGRAM                PAGE  1
CA PMA/DM 1.0 9010KS100          REPORT          FRI JAN 25 17:12:08 1991
                USING: DATABASE=, SUBSYS=DB23, WHATSQL=DB2

                A.                B.

INPUT:
COMMIT CB TEST XXXX

                CHARGEBACK COMMIT                PAGE  1_<_
                CONTROL REPORT                FRI JAN 18 17:12:09 1991

CA PMA/DM 1.0 9010KS100

CAKS689I - COMMIT TYPE: CB
CAKS689I - FROM VERSION: TEST
CAKS689I - TO VERSION: TESTXXXX
CAKS668I - CHARGEBACK CHECKING COMPLETE.
CAKS690I - DATABASE COMMIT BEING PERFORMED.
CAKS613I - COMMIT PROCESSING COMPLETED SUCCESSFULLY

```

### A.

SUBSYS=DB23:

This parameter is defined in CA PMA Chargeback CAIKSPAR parameter file and provides your database's SUBSYSTEM\_ID. This example uses DATABASE2 - DB23.

### B.

WHATSQL=DB2:

This parameter is defined in CA PMA Chargeback CAIKSPAR parameter file and identifies the type of SQL you are using: either DB2 or Datacom. This example uses DB2.

## The COPY Option

During Commit processing, the version of **all** existing definitions contained within the specified Development version are changed. In order to modify **any** definitions contained within the committed version, add new record definitions, delete any record definitions, it is necessary to **copy** the committed record definitions to one of the Development versions.

Copying of definitions is accomplished by executing the COPY option of the Archive/Restore program.

```
COPY CB fromver tover { REFRESH }
```

**where:**

**fromver**

The CA PMA Chargeback eight-character version to be copied from. The first four characters refer to the DataManager version and must be PROD or TEST and up to four characters that complete the CA PMA Chargeback version identifier.

**tover**

The four-character field which must be PROD or TEST (identifies the DataManager version).

**REFRESH**

Deletes all Development definitions currently contained in the *tover* prior to copying the requested committed version's definitions to the specified Development version.

## Example

To copy CA PMA Chargeback committed definitions TESTABC to the Development TESTxxxx version, use the following control statement:

```
COPY CB TESTABC TEST REFRESH
```

The following diagram shows you how different CA PMA Chargeback definition tables are referenced before and after use of the COPY option.

Table	Before Copy	After Copy	
	Version	New Dev. Develop.	Existing Committed
ACCSRTAB	TEST		TEST
ACCSTTAB	TEST		TEST
ACCTLOOK	TEST		TEST
PERTAB	TEST		TEST

Table	Before Copy	After Copy	
	Version	New Dev. Develop.	Existing Committed
CHOPTAB	TESTABC	TEST	TESTABC
ELEMTAB	TESTABC	TEST	TESTABC
MODTAB	TESTABC	TEST	TESTABC
NORMTAB	TESTABC	TEST	TESTABC
QUALTAB	TESTABC	TEST	TESTABC
QUERYTAB	TESTABC	TEST	TESTABC
RATETAB	TESTABC	TEST	TESTABC
SPLITTAB	TESTABC	TEST	TESTABC
SUMTAB	TESTABC	TEST	TESTABC

UNITTAB	TESTABC	TEST	TESTABC
	_____	_____	_____

## COPY Option JCL (CAKRCPY)

```
//CAKRCPY JOB (ACCTINFO), 'PMGR', CLASS=B, REGION=4M, MSGCLASS=X
//*****
/* PURPOSE: THIS JOB COPIES A COMMITTED VERSION OF THE
/*          CA PMA Chargeback TABLES TO A DEVELOPMENT VERSION
/*
/* INSTRUCTIONS:
/* 1. THIS JCL USES THE CAKSARES PROC PROVIDED IN THE SAMPJCL.
/*    EITHER COPY THE PROC TO THIS JCL OR ADD TO YOUR SYSTEM USER
/*    PROCLIB.
/* 2. MODIFY THE JOB CARD ACCORDING TO YOUR INSTALLATION STANDARDS.
/* 3. CHANGE THE HIGH LEVEL QUALIFIERS TO REFLECT THE CORRECT VALUES.
/* 4. MODIFY THE STEP010.SYSIN CONTROL STATEMENTS TO REFLECT THE
/*    APPROPRIATE PARAMETERS FOR PROCESSING.
//*****
//COPY EXEC PROC=CAKSARES,
//      INDEX='CAI',           <--- CUSTOMIZE
//      DCIND='CAI',          <--- CUSTOMIZE
//      SYSOUT='*'            <--- CUSTOMIZE
//*****
/* THE CONTROL STATEMENTS ARE PASSED TO THE *
/* CAKSARCH PROC BY THE STEP010.SYSIN DD.  *
/* MODIFY AS OUTLINED IN STEP 4           *
//*****
/*
//STEP010.SYSIN DD *
COPY CB TESTTEST TEST REFRESH
```

## Copy Option Output

When the Archive/Restore program successfully copies your tables, you receive printed output that looks like this:

```

CA                - Q  ARCHIVE/RESTORE PROGRAM                PAGE  1
CA PMA/DM 1.0 9010KS100          REPORT          FRI JAN 18 17:07:02 1991
                USING: DATABASE=, SUBSYS=DB23, WHATSQL=DB2

                A.          B.

INPUT:
COPY CB TESTTEST TEST REFRESH
CAKS563I Processing Table: PERTAB
CAKS564I Processing Complete for: PERTAB
CAKS563I Processing Table: ACCSRTAB
CAKS564I Processing Complete for: ACCSRTAB
CAKS563I Processing Table: ACCSTTAB
CAKS564I Processing Complete for: ACCSTTAB
CAKS563I Processing Table: ACCTLOOK
CAKS564I Processing Complete for: ACCTLOOK
CAKS563I Processing Table: ELEMENTAB
CAKS564I Processing Complete for: ELEMENTAB
CAKS563I Processing Table: RATETAB
CAKS564I Processing Complete for: RATETAB
CAKS563I Processing Table: UNITTAB
CAKS564I Processing Complete for: UNITTAB
CAKS563I Processing Table: QUALTAB
CAKS564I Processing Complete for: QUALTAB
CAKS563I Processing Table: NORMTAB
CAKS564I Processing Complete for: NORMTAB
CAKS563I Processing Table: MODTAB
CAKS564I Processing Complete for: MODTAB
CAKS563I Processing Table: SPLITTAB
CAKS564I Processing Complete for: SPLITTAB
CAKS563I Processing Table: CHOPTAB
CAKS564I Processing Complete for: CHOPTAB
CAKS563I Processing Table: SUMTAB
CAKS564I Processing Complete for: SUMTAB
CAKS575I END OF PROCESSING (0)
CAKS615I - COPY PROCESSING COMPLETED SUCCESSFULLY

```

### A.

SUBSYS=DB23:

This parameter is defined in CA PMA Chargeback CAIKSPAR parameter file and provides your database's SUBSYSTEM\_ID. This example uses DATABASE2 - DB23.

### B.

WHATSQL=DB2:

This parameter is defined in CA PMA Chargeback CAIKSPAR parameter file and identifies the type of SQL you are using: either DB2 or Datacom. This example uses DB2.

## CA PMA Chargeback Processing

### CA PMA Chargeback Daily Processing

The CA PMA Chargeback program, CAKRLOAD, reads the ORD Data file and uses the committed version of the definitions to apply charges to the CCCTAB (Consolidated Calculated Charges data table) and, if specified, create a Reconciliation file. This process uses two interdependent parameter files to process the ORD file:

- CAIKSPAR parameter provides global parameters for processing
- CAIKRPAR parameter provides specific control parameters for CA PMA Chargeback batch processing

The CAKRLOAD process also uses the Base Version (four-characters) specified in the CAIKSPAR parameter file during generation of the ORD Data file. To process this data using CAKRLOAD, the CAIKRPAR's BASE\_VERSION = parameter must refer to the same BASE\_VERSION = specified in the CAIKSPAR parameter file. That is, the first four characters of the eight-character CAIKRPAR BASE\_VERSION must be the same.

In other words, the selection of records for batch processing in CA PMA Chargeback is controlled via the CAIKRPAR BASE\_VERSION = parameter. Therefore, the records generated by DataManager must match the records requested by CA PMA Chargeback.

CAKRLOAD can optionally produce a Reconciliation file. This file can consume a very significant amount of disk space.

An optional user exit point is also provided for your convenience. Refer to The User Exit for CAKRLOAD for a detailed discussion of this feature.

**Caution** Daily processing does not perform checking for duplicate input.

#### CA PMA Chargeback Record Processing Overview

**Record processing is performed in the following order:**

- If a Shift Chop has been defined, any record meeting the defined criteria is **chopped** into the appropriate number of shifts.
- Charge unit calculations are performed.
- If normalizers have been defined, those records meeting the specified criteria have their charge units adjusted to reflect the appropriate normalization factor.
- Rate selection is performed. This includes determining whether qualified rates, or maximum or minimum rates should be applied.
- Charges are calculated (rate \* units).
- Split Charges are applied to the calculated charges.

- Modifiers are applied to the calculated charges.
- User exit is called if specified.

```

-----
| Shift Chop |
-----
  |
  v
-----
|   Unit   | Base Unit
-----|----- Calculated
  |
  v
-----
| Normalizers| Normalizers applied
-----|----- applied to unit
  |         | calculation
  v
-----
|Rate Select.| Qualifiers
-----|----- checked
  |
  v
-----
|Charges    |
| Calculated|
-----
  |
  v
-----
|Splits     |
| Applied   |
-----
  |
  v
-----
|Modifiers   |
| Applied   |
-----
  |
  v
-----
| User      |
| Exit     |
-----

```

## Control Parameters

The following control parameters used in the CAKRLOAD process are defined in the CAIKRPAR parameter file:

- BASE\_VERSION=
- CBLOAD\_VERSION=
- RECONCILIATION\_FILE=
- PERIOD\_FILE=

## Memory Requirements

Provide as much storage as possible for the CAKRLOAD process. If you find too much overhead is consumed, sort the ORD file by ORDID type (characters 1-3 of each record). This will reduce overhead.

## Temporary Work Area

The amount of temporary work area needed on DASD units varies depending on the volume of data to be processed and the type of DASD units used.

## Permanent Disk Space

The amount of permanent disk space needed for the reconciliation data file also varies depending on the volume of data to be processed and the type of DASD units used.

## Processing Recommendations

- If you plan to use the Reconciliation data file, establish Generation Data Groups to define its data set names. This allows you to avoid continual JCL modifications to CAKRLOAD.

For example:

```
//RECON DD DSN=PMA.RECON.DATA.FILE(+1)
```

This JCL outputs a new Reconciliation file each time CAKRLOAD is processed.

- Optional processing can be achieved by sorting the ORD Data File prior to input processing.

## Setup Checklist

It is recommended that you perform the following steps to ensure that correct DataManager and CA PMA Chargeback versions are specified for processing:

- Check the contents of the data set used by CAIKSPAR to verify that the BASE\_VER parameter is set to the correct version.
- Check the contents of the data set used by CAIKRPAR to verify that:
  - BASE\_VER and CB\_LOAD parameters are set to the correct eight-character CA PMA Chargeback version.
  - Any special processing you want is defined.
    - If you want to retain detail charge segments, specify RECON = Y.
    - PERIOD\_VERION is defined.
  - Review the CAKRLOAD JCL. If RECON = Y was specified in the CAIKRPAR data set:
    - A CAIKRREC DD statement is required in the CAKRLOAD JCL
    - The following DCB attributes are required:

```
REC= V  
LRECL= 32000  
BLKSIZE=32004  
DSORG=PS
```

## Daily Processing JCL (CAKRLoad)

```
//CAKRLoad JOB (ACCTINFO), 'PMGR', CLASS=B, REGION=4M, MSGCLASS=X
//*****
//* PURPOSE: THIS JOB STREAM READS the INSTALLED ORD DATA
//*          FILE AND USER THE COMMITTED VERSION OF THE
//*          CA PMA CHARGEBACK DEFINITIONS TO
//*          APPLY CHARGES TO THE CCCTAB.

//* INSTRUCTIONS:
//* 1. CUSTOMIZE THE INSTREAM PROC SYMBOLICS.
//* 2. IF YOUR DATABASE IS DB2, REMOVE THE DATACOM
//*    LIBRARIES AND UNCOMMENT THE DB2 LIBRARY AND
//*    REMOVE DCIND
//* 3. CUSTOMIZE THE DATA SET NAME OF THE CAIKSORD DD
//*    STATEMENT TO REFLECT THE DATA SET NAME OF THE
//*    FILE CREATED FROM CAKSLOAD.
//* 4. IF THE CAIKRPAR DATA SET CONTAINS RECON=NO, THEN
//*    COMMENT OUT OR REMOVE THE CAIKRREC DD STATEMENT.
//* 5. IF THE CAIKRPAR DATA SET CONTAINS RECON=YES, THEN
//*    CUSTOMIZE THE DATA SET NAME OF THE CAIKRREC DD
//*    STATEMENT.
//* 6. CUSTOMIZE THE JOB CARD ACCORDING TO YOUR
//*    INSTALLATION'S STANDARDS.
//* 7. SUBMIT THE JOB FOR PROCESSING.
//*****
//CBLOAD PROC SYSOUT='*',          /* SYSOUT CLASS
//          INDEX='CAI',          /* HIGH LEVEL INDEX OF CAILIB
//          DCIND='CAI',          /* HIGH LEVEL INDEX OF DATACOM
//          SIND='CAI',          /* HIGH LEVEL INDEX OF SORTLIB
//          DVOL='XXXXXX',        /* DISK VOL TO CREATE RECON FILE
//          PERMDA=DISK,          /* TEMPORARY GENERIC DASD UNIT
//STEP1 EXEC PGM=CAKRLoad
//STEPLIB DD DSN=&INDEX..CAJRLoad,DISP=SHR
//          DD DSN=&INDEX..CAICICS,DISP=SHR
//          DD DSN=&DCIND..USERLOAD,DISP=SHR      <-- DATACOM LIBRARY
//          DD DSN=&DCIND..INFOCAI.LOAD,DISP=SHR  <-- Datacom LIBRARY
//          DD DSN=&DCIND..LOAD,DISP=SHR         <-- Datacom LIBRARY
//          DD DSN=SYS2.DSNLOAD,DISP=SHR        <-- DB2
//SYSPRINT DD SYSOUT=TERM
//SYSOUT DD SYSOUT=TERM
//SORTMSG DD SYSOUT=TERM
//SORTLIB DD DSN=&SIND..SORTLIB,DISP=SHR
//SORTWK01 DD UNIT=&WORK.,SPACE=(CYL,(20,5),RLSE)
//SORTWK02 DD UNIT=&WORK.,SPACE=(CYL,(20,5),RLSE)
//SORTWK03 DD UNIT=&WORK.,SPACE=(CYL,(20,5),RLSE)
//SORTWK04 DD UNIT=&WORK.,SPACE=(CYL,(20,5),RLSE)
//SORTWK05 DD UNIT=&WORK.,SPACE=(CYL,(20,5),RLSE)
//SORTWK06 DD UNIT=&WORK.,SPACE=(CYL,(20,5),RLSE)
//SYSUDUMP DD SYSOUT=TERM
```

```
//SYSOUT DD SYSOUT=TERM

//*****
//* CAIKSPAR DD - DEFINES GLOBAL PMA PARMS
//* THIS STATEMENT IS REQUIRED.
//*
//*****
//*
//* CAIKSPAR DD DSN=&INDEX..CAIKSPAR,DISP=SHR
//*
//*****
//* CAIKRPAR DD - USED TO DEFINE CB/CHARGEBACK
//* PROCESSING OPTIONS
//* THIS STATEMENT IS REQUIRED.
//*
//*****
//*
//CAIKRPAR DD DSN=&INDEX..CAIKRPAR, DISP=SHR
//*
//*****
//* CAIKSORD DD DEFINES THE INPUT TO BE PROCESSED.
//* (ORD DATA FROM CAKSLOAD)
//*****
//*
//CAIKSORD DD DSN=&INDEX..DM.ORD.DATA.FILE(0),DISP=SHR <-- CUSTOMIZE
//*
//*****
//* CAIKRREC DD STATEMENT DEFINES GENERATION OF
//* THE RECONCILIATION FILE.
//* THIS STATEMENT IS REQUIRED IF THE CAIKRPAR CONTAINS
//* RECON=YES.
//*
//*****
//*
//CAIKRREC DD DSN=&INDEX..CB.OUTPUT.RECONC, <-- CUSTOMIZE
// UNIT=&PERMDA.,DISP=(NEW,CATLG,DELETE),
// SPACE=(CYL,(1,1)),VOL=SER=&DVOL.,
// DCB=(RECFM=VB,LRECL=32000,BLKSIZE=32004,DSORG=PS)
// PEND
//*
//STEP10 EXEC CBLOAD
//*
```

## The User Exit for CAKRLOAD

The following information describes the detail linkage conventions for interfacing to CA PMA Chargeback's user exit.

To accommodate installation accounting and reporting requirements not supported by CA PMA Chargeback standard features, a user exit routine is provided to augment or modify the actions normally taken. This user exit should be written in Assembler Language, although any language with standard IBM linkage is acceptable, such as COBOL.

The exit routine must reside in a LNKLST library or in the library in which CA PMA Chargeback resides, as indicated by the STEPLIB DD statement, or in a library concatenated to the STEPLIB DD statement.

It is not necessary to link edit an exit routine with any part of CA PMA Chargeback. The exit routines are compiled and linked independently of CA PMA Chargeback. CA PMA Chargeback uses a *late binding* technique of exit name specification.

The user exits use standard IBM linkage conventions. Upon entry from CA PMA Chargeback, the registers are as follows:

Register	Description
15	Address of exit routine's entry point
14	Return address
13	Address of register save area
1	Address of parameter list as defined on the next page

- Each call to any exit point by CA PMA Chargeback is identical, except the case of EOF on input. That is, there is no *first time* flag or signal to the exit.
- Please note that these exits do not have to be reentrant (RENT) nor reusable (REUS).
- The name of the exit's load module is up to you. The name you choose is specified in the CAKRLOAD\_EXIT parameter in the CAIKSPAR file.
- A dummy load module with the default name of CA\$KRLD is supplied in the CAJRLOAD library. If no name is specified in the CAKRLOAD\_EXIT parameter, this dummy module will be called.
- A default CA\$KRLD exit source module is provided, but we recommend that this source be used only as a sample in the creation of your own exit, and that you provide your own unique source and load module name.

This sample user exit is provided as member name CA\$KRLD in the CAJRSAMP library.

```

CA$KRLD  CSECT
*
*****
*
*      CA$KRLD - DUMMY EXIT ROUTINE FOR CAKRLD
*
* THIS ROUTINE SHOULD BE REPLACED BY THE USER IF AN EXIT ROUTINE IS
* NEEDED. IT MUST FOLLOW STANDARD IBM LINKAGE CONVENTIONS. THIS
* ROUTINE TAKES ONE PARAMETER WHICH IS A POINTER TO THE E15 PROCESS
* DATA BUFFER.
*
* THIS DUMMY ROUTINE RETURNS WITH A RETURN CODE OF ZERO.
*
* THE USER WRITTEN ROUTINE SHOULD:
*
*      RETURN ZERO MEANING WRITE, DO NOT CALL AGAIN
*      FOUR      WRITE, CALL AGAIN
*      EIGHT     DO NOT WRITE, DONE WITH EXIT PROCESSING
*
*      ANY OTHER RETURN CODE WILL CAUSE CAKRLD TO TERMINATE
*
*      FIELD          LENGTH  PARMAMETER  TYPE
*                   LIST +
*
*  VERSION           8        0        CHARACTER
*  ORDID             3        8        CHARACTER
*  STRUCTURE 1       16       11       CHARACTER
*  STRUCTURE 2       16       27       CHARACTER
*  STRUCTURE 3       16       43       CHARACTER
*  STRUCTURE 4       16       59       CHARACTER
*  STRUCTURE 5       16       75       CHARACTER
*  PERIOD NUMBER     4        91       BINARY
*  ELEMENT           16       95       CHARACTER
*  QUALIFIER         16       111      CHARACTER
*  MODIFIER          16       127      CHARACTER
*  RATE              8        143     PACKED
*  SPLIT FLAG        1        151     CHARACTER
*  MODIFIED FLAG     1        152     CHARACTER
*
*
*                   END OF THE SORT KEY
*
*  COUNT             4        153     BINARY
*  PERIODBILLED      4        157     BINARY
*  UNITS             8        161     PACKED
*  CHARGE            8        169     PACKED
*
*
*

```

```
*****
*
R1      EQU  1
R2      EQU  2
R3      EQU  3
R4      EQU  4
R5      EQU  5
R6      EQU  6
R7      EQU  7
R8      EQU  8
R9      EQU  9
R10     EQU 10
R11     EQU 11
R12     EQU 12
R13     EQU 13
R14     EQU 14
R15     EQU 15
*
          USING *,R15          ESTABLISH BASE REGISTER
          L      2,0(1)        LOAD REG WITH CALLER'S PARM LIST
*
*****
*
*      EXIT CODE GOES HERE
*
*****
*
          SLR   R15,R15          RETURN CODE ZERO FOR THIS STUB
          BR    R14
          LTORG
          END
```

## CAKRLoad Processing Summary Report

When CA PMA Chargeback successfully loads your tables, you receive printed output that looks like this:

CA RESTON QA		CHARGEBACK LOAD PROCESSING		PAGE 1
CA JARS/CB 1.0 9010KR100		SUMMARY REPORT		SAT JAN 13 17:08:57 1991
RECORDS READ:			397	
SPLIT RECORDS CREATED:			0	
ORIGINAL RECORDS CREATED:	C.		1985	
MODIFIED RECORDS CREATED:			0	
TOTAL NUMBER OF RECORDS CREATED:		-----	1985	
RECORDS INSERTED INTO CCCTAB:	F.		15	
RECORDS UPDATED IN CCCTAB:			5	
DATA MANAGER VERSION: PROD				
APPLICATION	STARTING	ENDING	RECORDS	
VERSION	PERIOD	PERIOD	READ IN	
ABCD (default)	0	0	397	
UNIT PRECISION:	3			
RATE PRECISION:	8			
CHARGE PRECISION:	4			

**Records Read:**

The number of records read from the ORD Data file.

**Split Records Created:**

If record is split according to SPLITTAF.

**Original Records Created:**

Records to which Shift Chop or Modifiers have been applied.

**Modified Records Created:**

If modifiers are applied to any ORD data records, this field reflects the number of modified records created.

**Total Number of Records Created:**

This is the total of B + C + D. The total number of charge elements.

**Records Inserted into CCCTAB:**

New, uniquely keyed records that have been added to the CCCTAB.

**Records Updated in CCCTAB:**

Existing records with matching keys. Updates count, units and charge.

**DataManager Version:**

The DataManager BASE\_VERSION contained in the CAIKRPAR during processing.

**APPLICATION VERSION**

All PERIOD\_FILE parameters are listed. However, the record count of the number of records read in pertains only to the version to which the data applies.

**ABCD**

The PERIOD\_VERSION specified in the CAIKRPAR file did **not** specify a CBLOAD\_VERSION. Therefore, the period processed defaulted to CB\_VERSION specified. In this case, ABCD.

**UNIT\_PREC:**

Displays the value specified in the CAIKSPAR parameter file.

**RATE\_PREC:**

Displays the value specified in the CAIKSPAR parameter file.

**CHARGE\_PREC:**

Displays the value specified in the CAIKSPAR parameter file.

## Batch Forecasting (CAKRFCB)

Future unit and charge consumption values can be projected or forecasted via the CAKRFCB program (member name CAKRFCST). The process uses the contents of the CCCTAB table to generate a CCCMOD table. The CCCMOD table is comprised of:

- data extracted from the CCCTAB
- forecast data based on the contents of the CCCTAB

You specify the forecast selection criteria and information needed to generate the CCCMOD table through the use of control statements.

**Note:** Each time you submit control statements for the batch forecast process, CA PMA Chargeback replaces the contents of the existing CCCMOD table with new forecasted data.

Once the CCCMOD table is generated, you can view detail unit and charge consumption values using the online Period functions facility. Do the following:

- Select **Options**, make sure that the Base and CB Version are equal to the version used in creating the CCCMOD table.
- Select **Period**
- Select **Forecasting**

The following defines CA PMA Chargeback forecast control statements. There are two types of control statements. These provide the forecast selection criteria and the information needed to create a CCCMOD table.

## CAKRFCST Control Statements

You enter the batch statements via the SYSIN DD statement of the CAKRFCST SAMPJCL.

The following keywords define CA PMA Chargeback Forecast control statements. The format is: **keyword** = value. If no value is specified for the control statement, all records from the CCCTAB table are applicable.

**ORD\_TYPE =**

Records from the CCCTAB table are selected based on this three-character output record identifier name.

**ELEMENT =**

Records from the CCCTAB table are selected based on this charge element (up to 16 alphanumeric characters).

**START\_PERIOD =**

The start of the range of records which are selected from the CCCTAB table. Selections for this control statement should be three-character numerics.

**END\_PERIOD =**

The end of the range of records which are selected from the CCCTAB table. Selections for this control statement should be three-character numerics.

**Note:** It is recommended that forecasting be performed only on closed periods. This ensures that the data used for forecasting is accurate. Refer to the period closing process for details.

**QUALIFIER =**

Records from the CCCTAB table are selected based on this conditional test. You can specify up to 16 alphanumeric characters.

**STRUCT1 =**

Specify the name of the defined accounting level for which records are selected.

**STRUCT2 =**

Specify the name of the defined accounting level for which records are selected.

**STRUCT3 =**

Specify the name of the defined accounting level for which records are selected.

**STRUCT4 =**

Specify the name of the defined accounting level for which records are selected.

**STRUCT5 =**

Specify the name of the defined accounting level for which records are selected.

The following control statements determine how the CCCMOD table is generated, and the form in which its contents are stored.

**AVERAGE =**

Determines if the projected periods that result from forecasting are stored individually or as one average projected period in the CCCMOD table. Valid entries are Y or N.

**ALGORITHM =**

The forecast method or copy function to be performed. Valid entries for this field are:

**COPY**

Records from the CCCTAB table are copied to the CCCMOD table based on the periods specified for the START\_PERIOD and END\_PERIOD control statements and any selection criteria.

**LINE**

The periods specified for the START\_PERIOD and END\_PERIOD control statements are used by the Line algorithm to compute the weighted moving average. The weighted moving average forecasts the number of periods specified for the NUMBER\_TO\_FORECAST control statement.

**SMOOTH**

The Smooth algorithm is an exponential method of forecasting. It is especially useful when recent consumption and charge values predict future values better than those of the more remote past. User-defined control statements Alpha and Delta are used as smoothing constants when Smooth is specified.

**ALPHA =**

This control statement is applicable only when SMOOTH is specified as the ALGORITHM. Alpha is used to modify or lessen the effects of short term or random changes. There is no default: up to four decimal values are permitted. Values can be between 0 and 1.

**DELTA =**

Is applicable only when SMOOTH is selected as the ALGORITHM. Delta is used to determine the level of smoothing and the speed of reaction to differences between forecasts and actual usage. Acceptable values are between 0 and 1.

**MODIFIER =**

A five-character control statement that determines how modifier records are used during the forecast process. Not applicable to the COPY algorithm. Valid entries include:

**YES**

Modifier records are treated as separate records for the forecast process. A forecast generated using this option depicts a true financial forecast.

**NO**

Modifier records are not considered during the forecast process. This option is used when you are concerned with unit utilization.

**MERGE**

If a given record has a modifier record(s) associated with it, the modifier record(s) is combined with the original record to form one record.

**NUMBER\_TO\_FORECAST =**

This control statement specifies the number of periods projected into the future. Acceptable values are three-character numerics. Not applicable to the COPY algorithm. Note:

- You can forecast up to half the number of completed periods selected from the CCCTAB table.
- No more than six periods can be forecasted.

**KEEP\_STRUCTURE =**

This control statement indicates the accounting levels maintained on the CCCMOD table. You can specify any number between 1 and 5, or 0. Not applicable to the COPY algorithm.

Records are grouped and summarized by the accounting level(s) selected. For example, entering a 1 indicates that the highest accounting level will be maintained. Records with **similar** highest accounting level are grouped and summarized on the CCCMOD table. Entering a 5 indicates that all accounting levels are maintained and no summarization is to take place.

**VERSION =**

Specifies the full eight-character CA PMA Chargeback version name used in the forecast. You can specify multiple versions by using the SQL wildcard character, along with any combination of alphanumeric characters. The VERSION control statement is used for both selection criteria and forecast generation.

**Note:** Before using the online Period functions to view the CCCMOD table, ensure that the version used in the Options function. is the same as the one specified for this control statement.

If you specify the SQL wildcard for this control statement, the CCCMOD table retains only the last version. This is the version that **MUST** be used in the Options function.

## Forecast Methods Summary

CA PMA Chargeback allows for three types of forecast methods: Manual, LINE and SMOOTH. All of these methods extract actual data from the CCCTAB table and either copies the data, or uses it to forecast data to the CCCMOD table. Once a CCCMOD table is created, the Period functions online facility can be used to perform **what if analysis** on the charge and unit consumption values.

### Manual

To perform a manual forecast, specify COPY for the ALGORITHM control statement. Once a copy of the selected records is made, you can adjust the values displayed on the various online forecasting panels.

### LINE

The Line algorithm computes the weighted moving average for the periods requested based upon historical data. It computes an average of the range of periods specified by the START\_PERIOD and END\_PERIOD control statements, giving each period a weight. The more recent the period, the greater the weight it is given. The average computed is then used as a forecast period.

If the value specified for the NUMBER\_TO\_FORECAST control statement is greater than one, each period forecasted is used to generate subsequent forecast periods. You can forecast up to six periods.

### SMOOTH

The Smooth algorithm is an exponential method of forecasting with trending. This method bases its forecast on recent consumption values rather than on remote ones. Two smoothing constants, ALPHA and DELTA are used to compute the forecast.

**ALPHA** is used to keep up with the changes in demand. It can be any value between 0 and 1. If the charge and unit consumption of the records of the CCCTAB vary slightly from one period to the next, a small value of alpha (<.4) should be used. If the values in the CCCTAB are increasing or decreasing quickly, a larger value of alpha (>.5) should be used.

Often over a period of time, the exponential forecast slightly differs from that of the actual occurrence. This is due to the upward or downward shifts in data. **DELTA**, a smoothing constant is part of a trend adjustment used to counter the affects of these shifts. It can be any value between 0 and 1.

**Note:** Forecast algorithms use only actual data from the CCCTAB to perform the forecast. Minimum and maximum charge values are **not** applied.

## Control Statement Summary

The following table shows which control statements are required (Req) or Optional (Optl) for processing each of the Forecast Algorithms.

FORECAST Control Statements	FORECAST Methods		
	Smooth	Line	Copy
ORD_TYPE	Optl	Optl	Optl
ELEMENT	Optl	Optl	Optl
QUALIFIER	Optl	Optl	Optl
STRUCT# (1 - 5)	Optl	Optl	Optl
START_PERIOD	Req	Req	Req
END_PERIOD	Req	Req	Req
NUMBER_TO_FORECAST	Req	Req	N/A
AVERAGE	Req	Req	Req
ALGORITHM	Req	Req	Req
MODIFIER	Req	Req	N/A
KEEP_STRUCTURE	Req	Req	N/A
ALPHA	Req	N/A	N/A
DELTA	Req	N/A	N/A
VERSION	Req	Req:	Req

Once information needed to generate the CCCMOD table is specified, the periods requested from the CCCTAB are used by the SMOOTH and LINE algorithms to project future periods. The first projected period is the period following the period specified for the END\_PERIOD control statement. Subsequent periods follow. For example, if 001 is specified for the START\_PERIOD, 004 is specified for the END\_PERIOD, and 002 is specified for the NUMBER\_TO\_FORECAST control statement, the periods forecasted are periods 5 and 6.

## Forecasting JCL (CAKRFCST)

```

//CAKRFCST JOB (ACCTINFO), 'PMGR', CLASS=A, REGION=4M, MSGCLASS=X
//*****
//* SAMPJCL TO EXECUTE CA PMA CB BATCH FORECASTING.
//*****
//* NOTE: THIS JOB WILL CREATE A NEW CCCMOD TABLE
//* NOTE: IF A CCCMOD CURRENTLY EXISTS, IT WILL BE DELETED
//* DURING THIS PROCESS.
//*****
//* THE FOLLOWING MODIFICATIONS WILL NEED TO BE MADE:
//*
//* 1. CHANGE THE HIGH LEVEL QUALIFIER OF THE STEPLIB DD
//* STATEMENTS TO REFLECT THE CORRECT HIGH LEVEL QUALIFIER.
//*
//* 2. IF YOUR DATABASE IS DB2, REMOVE THE Datacom LIBRARIES
//* FROM THE STEPLIB CONCATENATION AND ENSURE THAT THE
//* APPROPRIATE DB2 DATASET NAME IS INCLUDED IN THE STEPLIB.
//*
//* 3. BATCH FORECASTING CONTROL STATEMENTS ARE PROVIDED VIA THE
//* CAIKRFCS DD STATEMENT. REFER TO THE CA PMA Chargeback
//* USER GUIDE FOR DETAILS OF ALL FORECAST CONTROL STATEMENTS
//*
//*****
//*
//*
//STEP001 EXEC PGM=CAKRFCSB
//STEPLIB DD DSN=CAI.CAIJRLOAD,DISP=SHR <--- CUSTOMIZE
// DD DSN=CAI.CAICICS,DISP=SHR <--- CUSTOMIZE
// DD DSN=CAI.USERLOAD,DISP=SHR <--- Datacom LIBRARY
// DD DSN=CAI.INFOCAI.LOAD,DISP=SHR <--- Datacom LIBRARY
// DD DSN=CAI.LOAD,DISP=SHR <--- Datacom LIBRARY
//* DD DSN=SYS2.DSNLOAD,DISP=SHR <--- DB2 LIBRARY
//SYSPRINT DD SYSOUT=*
//*
//CAIKSPAR DD DSN=CAI.PMAPARM,DISP=SHR <--- CUSTOMIZE
//*****
//* DEFINE THE FORECAST CONTROL STATEMENTS AFTER THE*
//* CAIKRFCS DD STATEMENT. *
//*****
//CAIKRFCS DD *
START_PERIOD = 1 <--- CUSTOMIZE
END_PERIOD = 2 <--- CUSTOMIZE
ALGORITHM= LINE <--- CUSTOMIZE
VERSION = TESTTEST <--- CUSTOMIZE
MODIFIE = NO <--- CUSTOMIZE
NUMBER_TO_FORECAST = 1 <--- CUSTOMIZE
AVERAGE = YES <--- CUSTOMIZE

```

## Forecasting Control Reports

The following is a sample control report showing the **successful** generation of a CCCMOD table. The report shows the control statements that were used to create the CCCMOD table.

```
CA RESTON QA                                CHARGEBACK BATCH FORECASTING                PAGE 1
CA PMA CB 1.0 9010KR100                    CONTROL REPORT                               WED JAN 23 14:05:22 1991

CAKR834I PARAMETER LIST IS:
      ALPHA           =>  --
      AVERAGE        =>  --
      BETA            =>  --
      ELEMENT         =>  --
      END_PERIOD      =>  2
      ALGORITHM_TYPE  =>  LINE
      KEEP_STRUCTURE  =>  0
      MODIFIER        =>  N
      NUMBER_TO_FORECAST =>  1
      ORCID           =>  MBI
      QUALIFIER       =>  --
      START_PERIOD    =>  1
      STRUCT1         =>  --
      STRUCT2         =>  --
      STRUCT3         =>  --
      STRUCT4         =>  --
      STRUCT5         =>  --
      VERSION         =>  PRODABCD

CAKR835I SUCCESSFUL EXECUTION
```

**Note:** All available control statements are displayed on the report, even if they were not specified.

The following is a control report for a Forecasting job that did not complete successfully.

```
CA RESTON QA                                CHARGEBACK BATCH FORECASTING                PAGE 1
CA PMA CB 1.0 9010KR100                    CONTROL REPORT                               WED JAN 23 14:13:28 1991

CAKR818E - AVERAGE control statement must be YES or NO. MAYBE was specified
```

## Summary Processing (CAKRBREC)

The CAKRBREC summary processing program (member name CAKRSUM) should be run **once** per period, **after** all CAKRLOAD processing has been performed.

The Summary job uses the specified committed version's Cost Recovery and Overhead Distribution definitions to recover and/or distribute charges to all nonmodified CCCTAB records for the requested period. Modified records are *excluded* from CAKRBREC processing (for example, records in the CCCTAB with a value in the modifier field). This job uses the CAIKSPAR file. The period and version used in this process is defined via the PARM statement contained on the EXEC statement. The format for these values is shown below:

Summary processing does **not** change the original values contained within CCCTAB records. Instead, **additional** records are written to the CCCTAB, as is the case for modifier and split charge application during daily processing.

### Control Parameters

The control parameter value is specified on the EXEC statement.

```
PARM='Version Period'  
      |      |  
      |      -- 4-character period to be processed  
      |  
      -- 8-character version
```

### Summary Processing JCL (CAKRSUM)

```
//CAKRSUM JOB (ACCTINFO), 'PMGR', CLASS=B, REGION=4M, MSGCLASS=X
//*****
//* THIS SAMPJCL WILL BE USED BY CA PMA CB TO APPLY OVERHEAD
//* DISTRIBUTION AND COST RECOVERY ADJUSTMENTS.
//*
//* INSTRUCTIONS:
//* 1. USE THIS JOB AFTER ALL DATA FOR THE PERIOD HAS BEEN
//* PROCESSED (CAKRLoad).
//* 2. CHANGE THE PARM VALUES CONTAINED ON THE EXECUTE STATEMENT
//* TO REFLECT THE CORRECT CB VERSION AND THE PERIOD FOR
//* WHICH ADJUSTMENTS ARE TO BE PROCESSED.
//* 3. IF YOUR DATABASE IS DB2, REMOVE THE Datacom LIBRARIES AND
//* UNCOMMENT THE DB2 LIBRARY.
//* 4. CHANGE THE HIGH LEVEL INDEX OF THE STEPLIB DD STATEMENTS
//* TO REFLECT THE CORRECT VALUES.
//* 5. CHANGE THE CAIKSPAR DD STATEMENT TO REFLECT THE CORRECT
//* CAIKSPAR DATA SET NAME.
//* 6. CHANGE THE JOB CARD TO REFLECT YOUR INSTALLATION'S
//* STANDARDS.
//* 7. RUN THE JOB.
//*****
//STEP1 EXEC PGM=CAKRBREC, PARM='TESTXXX 0' <-- CUSTOMIZE PARM
//STEPLIB DD DSN=CAI.CAJRLOAD, DISP=SHR <-- CUSTOMIZE DSN
// DD DSN=CAI.CAICICS, DISP=SHR <-- CUSTOMIZE DSN
// DD DSN=CAI.USERLOAD, DISP=SHR <-- Datacom LIBRARY
// DD DSN=CAI.INFOCAI, DISP=SHR <-- Datacom LIBRARY
// DD DSN=CAI.LOAD, DISP=SHR <-- Datacom LIBRARY
//* DD DSN=SYS2.DSNLOAD, DISP=SHR <-- DB2 LIBRARY
//SYSPRINT DD SYSOUT=*
//CAIKSPAR DD DSN=&INDEX.CAIKSPAR, DISP=SHR <-- CUSTOMIZE DSN
```

### Summary Processing Report with Cost Recovery Rule

The following report shows information for one rule. Each rule generates its *own* section of this report.

```
CA RESTON QA                                CHARGEBACK LOAD PROCESSING
CA PMA Chargeback 1.0 9010KR100            OVERHEAD ALLOCATION AND COST RECOVERY REPORT
-----
CAKR887I FOR THE FOLLOWING RULE
RULE NAME: CPU-ADJUSTMENT                   A.
      C.          D.          E.
B.ERSION: PRODABCD  ORCID: MBJ  ELEMENT: CPU_CHARGE  QUALIFIER: NONE SPECIFIED  PERIOD: 2
STRUCTURES:
G.IVISION          NONE SPECIFIED DEPARTMENT  NONE SPECIFIED GROUP  NONE SPECIFIED
H.
SOURCE AMOUNT: 1000.0000                    I.
      529.4732 WAS ALLOCATED.                    J.
CAKR888I          999.9927 CURRENT DATABASE VALUE.
-----
CAKR893I END OF PROCESSING
```

- A.**  
RULE NAME:  
The Recovery name defined on the Cost Recovery primary panel.
- B.**  
VERSION:  
The committed CA PMA Chargeback version name that contains the definition or the version to which it should be applied.
- C.**  
ORDID:  
The output record identifier associated with the charge element whose result you want adjusted.
- D.**  
ELEMENT:  
The charge element whose result you want adjusted to ensure the recovery of the specified amount.
- E.**  
QUALIFIER:  
The name of a qualifier, if any, used in record selection.
- F.**  
PERIOD:  
The period for which the rule applies. In other words, the period from which the recovery amount should be captured.
- G.**  
STRUCTURES:  
Displays the names of the structures used in the recovery.
- H.**  
SOURCE AMOUNT:  
The amount defined for the rule. This amount is entered on the Cost Recovery Entry panel as Recovery Amount.
- I.**  
WAS ALLOCATED:  
Shows the *additional* charge amount generated that meets the cost recovery amount specified on the Cost Recovery Entry panel.
- J.**  
CURRENT DATABASE VALUE:

Displays the value *after* application of the rule.

## Period Processing Programs

### Period Close Processing (CAKRPCLS)

After the completion of period processing final invoice generation, it is recommended that the period be closed. CCCTAB records contain a field, PERIODB (period billed) that is updated during Period Close processing.

Period Close processing freezes the **current** summarized CCCTAB entries for the period just invoiced or closed. Period Close processing provides auditability of the invoice by preventing this period's summarized CCCTAB entries from being updated by any incoming ORD data.

### Control Parameters

The following control statement is input via the CAIKRINP DD statement:

```
VERSION=PRODXXXX,PERIOD=9999,PERIODB=9999
|           |           |
|           - period number -
-- 8-character
   committed version
   name
```

**where:**

#### **VERSION**

The name of the eight-character **committed** version.

#### **PERIOD**

The four-character period number defining the period for which the PERIODB value is applied (i.e., the period to close).

#### **PERIODB**

The four-character period number defining the value with which the PERIODB field is updated (i.e., the period billed).

**Note:** PERIODB should be the period in which this run was made (PERIODBilled).

## Setup Checklist

It is recommended that you perform the following steps to ensure that correct DataManager and CA PMA Chargeback versions are specified for processing:

- Check the contents of the data set used by CAIKSPAR to verify that the BASE\_VER parameter is set to the correct version.
- Check the contents of the data set used by CAIKRPAR to verify that:  
BASE\_VER and CB\_LOAD parameters are set to the correct eight-character CA PMA Chargeback version.
- PERIOD\_VERSION is defined.

## CAKRPCLS JCL

```
//CAKRPCLS JOB (ACCTINFO), 'PMGR', CLASS=A, MSGCLASS=X
//*****
/* THIS SAMPJCL IS USED TO CLOSE A PERIOD. ALL CCCTAB
/* RECORDS FOR THE SPECIFIED PERIOD WILL BE CLOSED BY UPDATING
/* THE VALUE IN THE PERIODB FIELD.
/*
/* INSTRUCTIONS:
/*
/* 1. IF YOUR DATABASE IS DB2, REMOVE THE Datacom LIBRARIES AND
/* UNCOMMENT THE DB2 LIBRARY.
/* 2. CHANGE THE INDEX OF THE STEPLIBS TO REFLECT THE CORRECT
/* HIGH LEVEL QUALIFIER.
/* 3. CHANGE THE CAIKSPAR AND CAIKRPAR DD STATEMENTS TO REFLECT
/* THE CORRECT HIGH LEVEL QUALIFIER.
/* 4. CHANGE THE VERSION CONTROL STATEMENT TO REFLECT THE
/* CORRECT, CB VERSION, PERIOD TO BE CLOSED AND THE PERIODB
/* VALUE.
/* 5. CHANGE THE JOB CARD TO REFLECT YOUR INSTALLATION'S
/* STANDARDS.
/* 6. RUN THE JOB.
//*****
//STEP1 EXEC PGM=CAKRPCLS
//STEPLIB DD DSN=CAI.CAJRLOAD, DISP=SHR <-- CUSTOMIZE
// DD DSN=CAI.CAICICS, DISP=SHR <-- CUSTOMIZE
// DD DSN=CAI.USERLOAD, DISP=SHR <-- Datacom LIBRARY
// DD DSN=CAI.INFOCAI.LOAD, DISP=SHR <-- Datacom LIBRARY
// DD DSN=CAI.LOAD, DISP=SHR <-- Datacom LIBRARY
//* DD DSN=SYS2.DSNLOAD, DISP=SHR <-- DB2 LIBRARY
//CAIKSPAR DD DSN=CAI.CAIKSPAR, DISP=SHR
//CAIKRPAR DD DSN=CAI.CAIKRPAR, DISP=SHR <-- CUSTOMIZE
//SYSPRINT DD SYSOUT=*
//*****
/* MODIFY THE VERSION CONTROL STATEMENT TO REFLECT THE DESIRED
/* CB VERSION, PERIOD AND PERIODB VALUES.
//*****
//CAIKRINP DD *
VERSION=TESTTEST, PERIOD=0001, PERIODB=0002
```

## Period Close Summary Report

CA RESTON QA	CHARGEBACK PERIOD CLOSE PROCESSING	PAGE 1
CA PMA Chargeback 1.0 CAKR9010KR100	SUMMARY REPORT	FRIDAY 1/18/1991
Options in effect		
Version = PRODABCD		
Period = 0001		
PeriodB = 0002		
DataBase = 3		
SSID = DB23		
CAKR957I - Processing completed		

## Period Open Processing (CAKRPOPJ)

The CAKRPOPJ job stream is provided so a closed period can be reopened or backed out.



## Period Open JCL (CAKRPOPJ)

```

//CAKRPOPJ JOB (ACCTINFO), 'PMGR', CLASS=A, MSGCLASS=X
//*****
//* THIS SAMPJCL WILL BE USED TO OPEN A CLOSED PERIOD. ALL CCCTAB
//* RECORDS FOR THE SPECIFIED PERIOD WILL BE OPEN BY UPDATING
//* THE VALUE IN THE SPECIFIED PERIODB FIELD TO BLANKS.
//*
//* INSTRUCTIONS:
//*
//* 1. IF YOUR DATABASE IS DB2, REMOVE THE Datacom LIBRARIES AND
//*    UNCOMMENT THE DB2 LIBRARY.
//* 2. CHANGE THE INDEX OF THE STEPLIBS TO REFLECT THE CORRECT
//*    HIGH LEVEL QUALIFIER.
//* 3. CHANGE THE CAIKSPAR AND CAIKRPAR DD STATEMENTS TO REFLECT
//*    THE CORRECT HIGH LEVEL QUALIFIER.
//* 4. CHANGE THE VERSION STATEMENT TO REFLECT THE CORRECT
//*    CB VERSION, PERIOD AND PERIODB VALUES.
//* 5. CHANGE THE JOB CARD TO REFLECT YOUR INSTALLATION'S
//*    STANDARDS.
//* 6. RUN THE JOB.
//*****
//STEP1   EXEC PGM=CAKRPOPJ
//STEPLIB DD DSN=CAI.CAJRLOAD,DISP=SHR          <-- CUSTOMIZE
//         DD DSN=CAI.CAICICS,DISP=SHR          <-- CUSTOMIZE
//         DD DSN=CAI.USERLOAD,DISP=SHR         <-- Datacom LIBRARY
//         DD DSN=CAI.INFOCAI.LOAD,DISP=SHR     <-- Datacom LIBRARY
//         DD DSN=CAI.LOAD,DISP=SHR             <-- Datacom LIBRARY
//*       DD DSN=SYS2.DSNLOAD,DISP=SHR
//CAIKSPAR DD DSN=CAI.CAIKSPAR,DISP=SHR        <-- CUSTOMIZE
//CAIKRPAR DD DSN=CAI.CAIKPAR,DISP=SHR         <-- CUSTOMIZE
//SYSPRINT DD SYSOUT=*
//*****
//* MODIFY THE VERSION STATEMENT THAT FOLLOWS THE CAIKRINP DD
//* STATEMENT.
//*****
//CAIKRINP DD *
VERSION=TESTTEST,PERIOD=0001,PERIODB=0002

```

## Period Open Processing Summary

CA RESTON QA	CHARGEBACK PERIOD OPEN PROCESSING	PAGE 1
CA PMA Chargeback 1.0 CAKR9010KR100	SUMMARY REPORT	FRIDAY 1/18/1991
Options in effect		
Version = PRODABCD		
Period = 0001		
PeriodB = 0002		
DataBase = 3		
SSID = DB23		
CAKR967I - Processing completed		

## Reporting with CA Earl

The CA Earl program is used in generation of **all** reports. Refer to the CA Earl documentation for information on how to customize reports and invoices.

### The CAKSEARL Procedure

The CAKSEARL procedure uses CA Earl to:

- Print ORD Data File for CA PMA Chargeback
- Generate the following CA PMA Chargeback reports:
  - Reconciliation reports
  - Invoices

### Report Control Statements

The CAJRJCL library contains different JCL members which execute the CAKSEARL PROC to generate various sample reports. Each of the sample JCL members use specific CAJREARL library members containing CA Earl report control statements. If you want to customize the CA Earl Report statements, create new CAJREARL members.

You **must** customize the CAKSEARL PROC (contained in the CAJRPROC library) and **must** either copy it to your system or user PROCLIB, or use it instream within each of the JCL members. Be sure to change the SSID to reflect the correct name of the database subsystem identifier.

On the next page you will find a sample of the CAKSEARL PROC.

## CAKSEARL Procedure

```

//*****
/* PROCEDURE CAKSEARL
/* USE FOR PRINTING CA PMA Chargeback ORD DATA FILE AND
/* RECONCILIATION FILE, AND GENERATING OF INVOICES
/*
/* MODIFICATIONS:
/* 1. UPDATE THE INSTREAM PROCEDURE PER THE INSTALLATION WORKSHEET.
/* 2. IF YOUR DATABASE IS DB2, REMOVE THE Datacom LIBRARIES AND
/* UNCOMMENT THE DB2 LIBRARY AND REMOVE DCIND
/* 3. BE SURE TO CUSTOMIZE THE PARM='SSID=' TO REFLECT THE OWNER'S
/* ID FOR Datacom, OR DB23 FOR DB2.
/*
/* NOTE: YOU MAY MOVE THIS PROCEDURE TO A PROCLIB, OR USE IT
/* INSTREAM.
/*
//*****
//CAKSEARL PROC INDEX='CAI', /* DATA SET HIGH LEVEL QUALIFIER
// DCIND='CAI', /* Datacom HIGH LEVEL QUALIFIER
// SYSOUT='*', /* SYSOUT CLASS
// WORK='SYSDA' /* UNIT NAME FOR TEMP DATA SETS
//EARL EXEC PGM=EarL,PARM='SSID=DB23',TIME=1440
//STEPLIB DD DISP=SHR,DSN=&INDEX..CAJRLOAD
// DD DISP=SHR,DSN=&INDEX..CAICICS
// DD DISP=SHR,DSN=&DCIND..USERLOAD <-- Datacom LIBRARY
// DD DISP=SHR,DSN=&DCIND..INFOCAI.LOAD <-- Datacom LIBRARY
// DD DISP=SHR,DSN=&DCIND..LOAD <-- Datacom LIBRARY
/* DD DISP=SHR,DSN=SYS2.DSNLOAD <-- DB2 LIBRARY REL. 1.3
//EARLLIB DD DISP=SHR,DSN=&INDEX..CAJREARL
/*
//CAIKSPAR DD DISP=SHR,DSN=&INDEX..CAIKSPAR
//SYSPRINT DD SYSOUT=&SYSOUT.
//SYSOUT DD SYSOUT=&SYSOUT.
//SYSUDUMP DD SYSOUT=&SYSOUT.
//SORTMSG DD SYSOUT=&SYSOUT.
//SYSEARL DD SYSOUT=&SYSOUT.
//EARLOBJ DD UNIT=&WORK.,SPACE=(CYL,(10,5))
//WORK1 DD UNIT=&WORK.,SPACE=(CYL,(1,1))
//SYSUT1 DD UNIT=&WORK.,SPACE=(CYL,(1,1))
//SYSUT2 DD UNIT=&WORK.,SPACE=(CYL,(1,1))
//SYSUT3 DD UNIT=&WORK.,SPACE=(CYL,(1,1))
//SYSUT4 DD UNIT=&WORK.,SPACE=(CYL,(9,1))
//SYSUT5 DD UNIT=&WORK.,SPACE=(CYL,(9,1))
//SYSUT6 DD UNIT=&WORK.,SPACE=(CYL,(9,1))
//SORTIN DD DSN=&.&TMPFL1.,UNIT=SYSSQ,DISP=(NEW,DELETE),
// SPACE=(CYL,(10,1))
//SORTOUT DD DSN=&.&TMPFL2.,UNIT=SYSSQ,DISP=(NEW,DELETE),
// SPACE=(CYL,(10,1))
//SORTWK01 DD UNIT=SYSSQ,SPACE=(TRK,(100))

```

```
//SORTWK02 DD UNIT=SYSSQ,SPACE=(TRK,(100))  
//SORTWK03 DD UNIT=SYSSQ,SPACE=(TRK,(100))
```

## Reconciliation Reports

The CAKRECON member in the CAJRJCL library executes the CAKSEARL procedure in order to produce the following Reconciliation reports:

- Detail Reconciliation Report, shown on page Detailed Charges by STRUCT3, Period, Jobstep & Element (CAKRECN1), uses CAJREARL member CAKRECN1
- Summary Reconciliation Report, shown on page Charges by STRUCT3, Period, Jobstep, Summed by Element (CAKRECN2), uses CAJREARL member CAKRECN2

Reconciliation Reports allow you to view input data **after** performing a CAKRLOAD. These reports are useful for audit purposes, especially if questions arise concerning charges. The reconciliation reports provide the detail information that is used in creating the CCCTAB.

**Note:** In order to produce reconciliation reports, you must create the Reconciliation file in CAKRLOAD.

The Reconciliation report allows you to view the detail of all charges in segments for every ORD contained on the ORD data file. The sample reports shown on the following pages reflect the detail charge segment of an ORD data file.

## CAKRECON JCL

```
//CAKRECON JOB (ACCTINFO), 'PMGR', CLASS=A, MSGCLASS=X
//*****
//* THIS SAMPJCL WILL BE USED TO PRINT THE CA PMA Chargeback RECON FILE.
//*
//* INSTRUCTIONS:
//* 1. THE CAKSEARL PROCEDURE INVOKED IN THIS JCL MEMBER MAY BE
//*    RUN INSTREAM OR FROM A SYSTEM OR USER PROCEDURE LIBRARY.
//* 2. CHANGE THE CAIKREC DD STATEMENT TO REFLECT THE CORRECT
//*    DATASET NAME.
//* 3. SELECT THE TYPE OF RECON REPORT DESIRED. UNCOMMENT THE
//*    SYSIN DD STATEMENT AND COMMENT THE REMAINING SYSIN DD
//*    STATEMENTS.
//*    CAJREARL(CAKRECN1) WILL PRODUCE A DETAIL RECON REPORT.
//*    CAJREARL(CAKRECN2) WILL PRODUCE A SUMMARIZED RECON REPORT.
//* 4. MAKE SURE THE HIGH LEVEL QUALIFIERS HAVE BEEN CUSTOMIZED
//*    IN THE PROC.
//* 5. CHANGE THE JOB CARD TO REFLECT YOUR INSTALLATION STANDARDS
//* 6. RUN THE JOB.
//*****
//*
//EARL      EXEC CAKSEARL
//SYSEARL   DD SYSOUT=*
//CAIKREC   DD DISP=SHR, DSN=&INDEX. .CB.OUTPUT.RECONC    <--- CUSTOMIZE
//SYSIN     DD DSN=&INDEX. .CAJREARL(CAKRECN1), DISP=SHR
//*SYSIN    DD DSN=&INDEX. .CAJREARL(CAKRECN2), DISP=SHR
/*
```

### Sample CAJREARL Member: CAKREC1

```
OPTION PRINTER = 132 NODUMP
!
! THIS JOB ILLUSTRATES THE USE OF CA Earl TO PRINT RECORDS
! FROM THE RECON FILE USING THE CAKRERL1 GET ROUTINE.
! THIS EXAMPLE PRINTS EACH DETAILED CHARGE RECORD, FOR EACH
! ELEMENT, FOR EACH PERIOD, FOR EACH STRUCT3
!
USER 'CA PMA Chargeback RECON EXAMPLE 1'
RECON: FILE CAKRERL1 RECORD=1500
COPY CBDEF1
!
REPORT 'DETAILED CHARGES BY GROUP BY PERIOD, JOBNAME, ELEMENT'
TITLE 'GROUP = ' STRUCT3
TITLE 'PERIOD =' PERIOD
CONTROL
    (STRUCT3 ) SKIP
    (PERIOD ) SKIP
    (JOBNAME )
    ELEMENT
PRINT
    JOBNAME
    STARTSTAMP
    ELEMENT
    QUAL
    MODIFIER
    UNITS
    RATE
    (CHARGE)
END
```

All of the Reconciliation reports have similar headings as described below.

26/09/90	A. CA PMA Chargeback RELEASE 1.0 RECON EXAMPLE 1	PAGE	2
B.	C. DETAILED CHARGES BY STRUCT3 BY PERIOD, JOBSTEP, ELEMENT	D.	
	LOCATION = DALLAS		
	PERIOD = 2		
	-----E.-----		
	F.		

**A.**

Displays the name of the report.

**B.**

Displays the date the report was printed.

**C.**

Displays the report title.

**D.**

Displays the page number.

**E.**

Displays the Accounting Structure and the entity within the structure to which the information on page refers. In this case, the entity is a structure named location for an entity named Dallas. Accounting structure information is defined using CA PMA Chargeback's online Cbdefs facility. The structure and entity names are derived from the Accounting Structure, Accounting Sources and Accounting Sources Lookup tables.

**Note:** Information for each entity within the structure prints on a separate page.

**F.**

Tells you the **period** for which the information is valid. This period number was defined using CA PMA Chargeback's online Cbdefs facility.

### Detailed Charges by STRUCT3, Period, Jobstep & Element (CAKREC�1)

This job illustrates the use of CA Earl to print records from the RECON file using the CAKRERL1 GET routine. This example prints each detailed charge record, for each Charge Element, for each period, for each STRUCT3.

26/09/90		CA PMA Chargeback RELEASE 1.0 RECON EXAMPLE 1					PAGE 2	
DETAILED CHARGES BY STRUCT3 BY PERIOD, JOBSTEP, ELEMENT								
LOCATION = DALLAS								
PERIOD = 2								
A.	B.							
JOBNAME	STARTSTAMP	ELEMENT	QUAL	MODIFIER	UNITS	RATE	CHARGE	
	C.	D.	E.	F.	G.			
ACCUCHK	198505281338260000	CPU_CHARGE	DEFAULT		31.464	0.27777000	8.7398	
ACCUCHK	198505281338260000	DISK_CHARGE	DEFAULT		0.525	9.00000000	4.7250	
ACCUCHK	198505281338260000	PRINT_CHARGE	DEFAULT		0.000	2.00000000	0.0000	
ACCUCHK	198505281338260000	TAPE_CHARGE	DEFAULT		0.000	5.00000000	0.0000	
ACCUCHK							13.46481	
ALLOCATE	198505281323250000	CPU_CHARGE	DEFAULT		0.072	0.27777000	0.0200	
ALLOCATE	198505281323250000	DISK_CHARGE	DEFAULT		0.000	9.00000000	0.0000	
ALLOCATE	198505281323250000	PRINT_CHARGE	DEFAULT		0.000	2.00000000	0.0000	
ALLOCATE	198505281323250000	TAPE_CHARGE	DEFAULT		0.000	5.00000000	0.0000	
ALLOCATE							0.0200	
ALLOCD5	198505281050210000	CPU_CHARGE	DEFAULT		0.036	0.27777000	0.0100	
ALLOCD5	198505281050210000	DISK_CHARGE	DEFAULT		0.000	9.00000000	0.0000	
ALLOCD5	198505281050210000	PRINT_CHARGE	DEFAULT		0.000	2.00000000	0.0000	
ALLOCD5	198505281050210000	TAPE_CHARGE	DEFAULT		0.000	5.00000000	0.0000	
ALLOCD5							0.0100	
BALCONV	198505281103350000	CPU_CHARGE	DEFAULT		3.168	0.27777000	0.8800	
BALCONV	198505281103350000	DISK_CHARGE	DEFAULT		0.104	9.00000000	0.9360	
BALCONV	198505281103350000	PRINT_CHARGE	DEFAULT		0.000	2.00000000	0.0000	
BALCONV	198505281103350000	TAPE_CHARGE	DEFAULT		0.000	5.00000000	0.0000	
BALCONV							1.8160	
BLOC4	198505281154320000	CPU_CHARGE	DEFAULT		4.428	0.27777000	1.2300	
BLOC4	198505281329520000	CPU_CHARGE	DEFAULT		0.864	0.27777000	0.2400	
BLOC4	198505281329520000	DISK_CHARGE	DEFAULT		0.061	9.00000000	0.5490	
BLOC4	198505281154320000	DISK_CHARGE	DEFAULT		1.181	9.00000000	10.6290	
BLOC4	198505281154320000	PRINT_CHARGE	DEFAULT		0.000	2.00000000	0.0000	
BLOC4	198505281329520000	PRINT_CHARGE	DEFAULT		0.000	2.00000000	0.0000	
BLOC4	198505281329520000	TAPE_CHARGE	DEFAULT		0.000	5.00000000	0.0000	
BLOC4	198505281154320000	TAPE_CHARGE	DEFAULT		0.000	5.00000000	0.0000	
BLOC4							12.6480	
BSRCH	198505281328040000	CPU_CHARGE	DEFAULT		0.828	0.27777000	0.2300	
BSRCH	198505281328040000	DISK_CHARGE	DEFAULT		0.007	9.00000000	0.0630	
BSRCH	198505281328040000	PRINT_CHARGE	DEFAULT		0.000	2.00000000	0.0000	
BSRCH	198505281328040000	TAPE_CHARGE	DEFAULT		0.000	5.00000000	0.0000	
BSRCH							0.2930	

- A.**  
JOBNAME is obtained from the CA JARS history file used as input to DataManager.
- B.**  
STARTSTAMP is obtained from DataManager via its ORD Header Record.
- C.**  
ELEMENT is the CA PMA Chargeback Charge Element name defined using the CA PMA Chargeback's online Cbdefs facility.
- D.**  
QUAL indicates if a qualified rate as defined using CA PMA Chargeback's online Cbdefs facility is being applied in the charge calculation. In this case, the DEFAULT is used. The default rate is also defined using Cbdefs.
- E.**  
MODIFIER indicates if a modifier as defined using CA PMA Chargeback's online Cbdefs facility is to be applied to the calculated charge. In this case, no modifier is being applied as indicated by the blank.
- F.**  
UNITS displays the calculated charge units (defined using Cbdefs) for each charge element.
- G.**  
RATE displays the charge rate (defined using Cbdefs) being applied in the charge calculation.
- H.**  
CHARGE displays the calculated charge for the charge element.
- I.**  
Displays the total calculated charge for the Jobname: ACCUCHEK.

### Charges by STRUCT3, Period, Jobstep, Summed by Element (CAKREC2)

This job illustrates the use of CA Earl to print records from the RECON file using the CAKRERL1 GET routine. This example sums all charges for each element, for each job step, for each period, for each STRUCT3.

19/02/91		CA PMA Chargeback RECON EXAMPLE 2		PAGE 30
		SUMMARY CHARGES BY GROUP BY PERIOD, JOBNAME, ELEMENT		
		GROUP = E DENVER		
		PERIOD = 2		
-----		-----		
A.	JOBNAME	ELEMENT	CHARGE	
-----		B.	C.	
-----		-----		
	UNLOAD	PRINT - CHARGE	0.0000	
	UNLOAD	SPEC - CHARGE	694.8000	
	UNLOAD	TAPE - CHARGE	5.5250	
	UNLOAD		-----	
			701.4356	D.
	VLTABLE	CPU - CHARGE	0.1008	
	VLTABLE	DISK - CHARGE	0.0630	
	VLTABLE	PRINT - CHARGE	0.0000	
	VLTABLE	SPEC - CHARGE	147.6000	
	VLTABLE	TAPE - CHARGE	0.0000	
	VLTABLE		-----	
			147.7638	D.
	WENDYM	CPU - CHARGE	10.3320	
	WENDYM	DISK - CHARGE	424.4490	
	WENDYM	PRINT - CHARGE	0.0000	
	WENDYM	SPEC - CHARGE	37324.8000	
	WENDYM	TAPE - CHARGE	0.0000	
	WENDYM		-----	
			37759.5810	D.
	ZAP73	CPU - CHARGE	0.0288	
	ZAP73	DISK - CHARGE	0.1530	
	ZAP73	PRINT - CHARGE	0.0000	
	ZAP73	SPEC - CHARGE	39.6000	D.
	ZAP73	TAPE - CHARGE	0.0000	
	ZAP73		-----	
			39.7818	D.
			-----	
			97945.0812	E.
			-----	
GRAND TOTAL			97945.0812	F.
			-----	

- A. JOBNAME is obtained from the CA JARS history file used as input to DataManager.
- B. ELEMENT is the CA PMA Chargeback Charge Element name defined using the CA PMA Chargeback's online Cbdefs facility.
- C. **CHARGE** displays the calculated charge for each charge element.
- D. Displays the total calculated charge for the Jobname.
- E. Displays the total charges for period 2.
- F. Displays the grand total of charges.

## Generating CA PMA Chargeback Invoices

CAJRJCL member CAKRINVC executes the CAKSEARL procedure in order to produce the following invoices:

- Example 1, uses CAJREARL member CAKRINV1 to generate a invoice using **only** data from the CCCTAB.
- Example 2, uses CAJREARL member CAKRINV2 to generate a summary invoice using data from the CCCTAB, BUDTAB and DBCRTAB.
- Example 3, uses CAJREARL member CAKRINV3 to generate an invoice using data from the CCCTAB, BUDTAB and DBCRTAB.

The CA Earl source statements required for the generation of these reports reside in the CAJREARL library downloaded during installation.

**Note:** You **must** customize the sample invoices to reflect your accounting structure and create new CAJREARL members for each report.

You should execute this job stream **after** all data from the period has been processed (CAKRLOAD) and **after** completion of summary processing (CAKRSUM). When you have completed generating the invoice, you may want to close this periods' processing. Refer to CAKRPLS for details.

## CAKRINVC JCL

```
//CAKRINVC JOB (ACTINFO),'PMGR',CLASS=A,MSGCLASS=X
//*
//*****
//* SAMPJCL TO PRINT CA PMA Chargeback INVOICES.
//* INSTRUCTIONS:
//* 1. THIS JCL USES THE CAKSEARL PROC PROVIDED IN
//*    THE SAMPJCL. EITHER COPY THE PROC TO THIS JCL OR
//*    ADD TO YOUR USER PROCLIB. CUSTOMIZE THE PROC TO
//*    REFLECT THE CORRECT HIGH LEVEL QUALIFERS.
//* 2. MODIFY THE JOB CARD ACCORDING TO YOUR INSTALLATION
//*    STANDARDS.
//* 3. ENSURE THAT THE SYSIN DD STATEMENT IS CHANGED TO
//*    REFLECT THE CORRECT HIGH LEVEL QUALIFIER.
//* 4. TO PROCESS EXAMPLE 1 - USE THE SYSIN DD WITH CAJREARL
//*    (CAKRINV1).
//* 5. TO PROCESS EXAMPLE 2 - USE THE SYSIN DD WITH CAJREARL
//*    (CAKRINV2).
//* 6. TO PROCESS EXAMPLE 3 - USE THE SYSIN DD WITH CAJREARL
//*    (CAKRINV3).
//* 7. IF CUSTOMIZATION IS REQUIRED, COPY THE PROVIDED
//*    CAJREARL MEMBERS TO NEW MEMBER(S). THEN CUSTOMIZE
//*    THE NEW MACLIB MEMBER(S).
//*****
//*
//Earl    EXEC CAKSEARL
//SYSEarl DD SYSOUT=*
//SYSIN   DD DSN=&INDEX..CAJREARL(CAKRINV1),DISP=SHR <-- CUSTOMIZE
//*SYSIN  DD DSN=&INDEX..CAJREARL(CAKRINV2),DISP=SHR <-- CUSTOMIZE
//*SYSIN  DD DSN=&INDEX..CAJREARL(CAKRINV3),DISP=SHR <-- CUSTOMIZE
/*
```

## Sample CAJREARL (CAKRINV1) Member for Invoice Example 1

This example uses CAJREARL member CAKRINV1 to generate a detail invoice using **only** data from the CCCTAB.

```

!
!   INVOICE EXAMPLE #1
!
! THIS JOB ILLUSTRATES THE USE OF EarL TO PRINT RECORDS FROM
! THE CHARGEBACK CCCTAB, DATABASE TO CREATE
! INVOICES USING THE CAKRERL2 GET ROUTINE.
!
! THIS IS A DETAIL INVOICE, SHOWING COUNT, UNITS, RATE AND CHARGE
! FOR EACH ORDID/ELEMENT/QUALIFIER/MODIFIER, FOR EACH STRUCT3.
!
! SORT ORDER IS VERSION, PERIOD, STRUCT1-STRUCT3, ORDID,
! ELEMENT, QUALIFIER, MODIFIER.
!
! PAGE BREAK IS BY STRUCT3, LINE BREAK IS BY ORD AND ELEMENT,
! AND EACH LINE IS AN ORDID/ELEMENT/QUALIFIER/MODIFIER COMBINATION.
!
USER 'CA PMA Chargeback INVOICE EXAMPLE 1'
!
OPTION PRINTER = 132    NODUMP
!
  CBREC:   FILE CAKRERL2 RECORD=2000
  COPY CBDEF2
!
COPY CBGSA
!
COPY CBSET
!
REPORT 'DETAIL BY ORD/ELEMENT/QUALIFER/MODIFIER, PAGE BY GROUP'
TITLE 'VERSION='   PVERSION
TITLE 'PERIOD='    PPERIOD
TITLE 'DIVISION='  PSTRUCT1
TITLE 'DEPARTMENT=' PSTRUCT2
TITLE 'GROUP='    PSTRUCT3
NOTE
NOTE   SELECT ONLY TYPE 1 RECORDS AS THIS REPORT DOES NOT
NOTE   LIST BUDGETS OR DEBITS/CREDITS
NOTE
SELECT PTYPE = 1
CONTROL SKIP
      (PVERSION)
      (PPERIOD)
      (PSTRUCT1 )
      (PSTRUCT2 )
      (PSTRUCT3 ) SKIP
      (PORDID)

```

```

(PLEMENT ) BREAK
PQUAL
PMODIFIER
PRATE
PFLAGS
PTYPE
SET(D) PCNT= TCNT
SET(D) PUNITS=TUNITS
SET(D) PCHARGE = TCHARGE

NOTE
NOTE SUPPRESS PRINTING CNT AND UNITS TOTALS ABOVE ELEMENT
NOTE LEVEL AS THEY WOULD BE MEANINGLESS
NOTE
IF(T) &CTRLBREAK. = 1
    SET(T) PCNT = TCNT
    SET(T) PUNITS = TUNITS
ELSE
    SET(T) PCNT = 0
    SET(T) PUNITS = 0
ENDIF
NOTE
NOTE SUPPRESS PRINTING TOTALS ABOVE PAGE LEVEL
NOTE
IF(T) &CTRLBREAK. <= 3 THEN SET(T) PCHARGE = TCHARGE
ELSE SET(T) PCHARGE = 0 ENDIF
!
PRINT          PORDID
                PELEMENT
                PQUAL
                PMODIFIER
                (PCNT)
                (PUNITS)
                PRATE
                (PCHARGE)

END
    
```

All invoices have similar headings as described below.

22/01/91	A.	CA PMA Chargeback INVOICE EXAMPLE 1	PAGE	1
B.	C.	DETAIL BY ORD/ELEMENT/QUALIFER/MODIFIER, PAGE BY GROUP	D.	
		VERSION= TESTCHAR		
		PERIOD= 1		
	E. }	DIVISION= C MICRO		
		DEPARTMENT= F.E ORDERING	G.	
		GROUP= A DALLAS		
-----				

- A.**  
Displays the invoice name.
- B.**  
Displays the date the invoice was printed.
- C.**  
Displays the invoice title.
- D.**  
Displays the page number.
- E.**  
Tells you the CA PMA Chargeback **version** used to generate the invoice.
- F.**  
Tells you the **period** that the invoice covers.
- G.**  
Displays the accounting structure and entity within the structure to which the invoice applies. In this case, it is for the A Dallas Group within the E Ordering Department, that is part of the C Micro Division. Accounting structure information is defined using CA PMA Chargeback's online Cbdefs facility. The structure and entity names are derived from the Accounting Structure, Accounting Sources and Accounting Sources Lookup tables.  
**Note:** Information for each entity within the structure prints on a separate page.

### Invoice Example 1: Detail by ORD/Element/Qualifier/Modifier (Paged by Group)

This example uses CAJREARL member CAKRINV1 to generate a invoice using **only** data from the CCCTAB.

22/01/91		CA PMA Chargeback INVOICE EXAMPLE 1 DETAIL BY ORD/ELEMENT/QUALIFIER/MODIFIER, PAGE BY GROUP						PAGE 1
		VERSION= TESTCHAR		PERIOD= 1		DIVISION= C MICRO		
		DEPARTMENT= E ORDERING		GROUP= A DALLAS				
A. RDID	B. ELEMENT	C. QUALIFIER	D. MODIFIER	E. COUNT	F. UNITS	G. RATE	CHAR	
MBJ	@SPEC - CHARGE	@SHIFT1	---	3	654.16	\$100.00	\$65,415.60	
MBJ	@SPEC - CHARGE			3	654.16		\$65,415.60	
		DEFAULT	---	3	498.96	\$0.28	\$138.60	
MBJ	CPU - CHARGE			3	498.96		\$138.60	
		DEFAULT	---	3	9.38	\$9.00	\$84.43	
MBJ	DISK - CHARGE			3	9.38		\$84.43	
		DEFAULT	---	3		\$2.00		
MBJ	PRINT - CHARGE			3				
		DEFAULT	---	3		\$5.00		
MBJ	TAPE - CHARGE			3				
MBJ							I. \$65,638.63	
							\$65,638.63	

**A.**

ORDID:

The ORD type for which charges are calculated.

**B.**

ELEMENT:

The charge element used to calculate the charge.

**C.**

QUALIFIER:

Tells you whether the default rate was used or if a rate qualifier was applied during the calculation of the charge element.

**D.**

MODIFIER:

Tells you whether a modifier was applied to the charge element.

**E.**

COUNT:

Displays the number of records that met the conditions in order to calculate the charge.

**F.**

UNITS:

Displays the unit value used in the calculation.

**G.**

RATE:

Displays the rate used to calculate the charge.

**H.**

CHARGE:

Displays the calculated charge for the ORD type and charge element listed in columns A and B.

**I.**

Total:

Displays the total charges. Charge element listed in columns A and B.

## Invoice Example 2: Summary Charges by Group

This example uses CAJREARL member CAKRINV2 to generate a summary invoice using data from the CCCTAB, BUDTAB and DBCRTAB.

22/01/91		CA PMA Chargeback INVOICE EXAMPLE 2					PAGE 1	
		SUMMARY CHARGES BY GROUP						
		VERSION= TESTCHAR						
		PERIOD= 1						
		DIVISION= C MICRO						
		DEPARTMENT= E ORDERING						
		GROUP= A DALLAS						
-----		-----		-----		-----		
COUNT	CHARGE	CREDIT	DEBIT	ADJUSTED	BUDGET	PERCENT		
A.	B.	C.	D.	E. CHARGE	F.			
-----		-----		-----		-----		
5	\$1,164.60			\$1,164.60		*****		
5	\$1,164.60			\$1,164.60		*****		
5	\$1,164.60			\$1,164.60		*****		

**A.**

COUNT:

Displays the number of records used in the calculation.

**B.**

CHARGE:

Displays the charges for the accounting structures printed at the top of the invoice.

**C.**

CREDIT:

When applicable, displays an amount that adjusts the final charge.

**D.**

DEBIT:

When applicable, displays an amount that adjusts the final charge.

**E.**

ADJUSTED CHARGE:

Displays the final charge after all debits and credits have been applied.

**F.**

BUDGET:

Displays the allocated budget amount for the structures and period printed at the top of the invoice.

**G.**

PERCENT BUDGET:

Displays the percentage of the entity's budget that has been spent.

### Invoice Example 3: Charges by Group and Person (Paged by Structure 2)

This example uses CAJREARL member CAKRINV3 to generate an invoice using data from the CCCTAB, BUDTAB, and DBCRTAB. Note that this invoice lists all structure3 entities (see **A** below) for the specified version that fall within Structure1 (Division) and Structure2 (Department) with the Invoice paged by Department. There is also a summary line for each structure3 entity.

CA PMA Chargeback INVOICE EXAMPLE 3											
22/01/91		CHARGE INVOICE BY GROUP, BY PERIOD, PAGE BY DEPARTMENT								PAGE 1	
VERSION= TESTCHAR											
DIVISION= B SPD											
DEPARTMENT= B PROGRAMMING											
STRUCT3	B.	PERIOD	COUNT	CHARGE	CREDIT	DEBIT	ADJUSTED	BUDGET	PERCE		
A.			C.	D.	E.	F.	G. CHARGE				
C MIAMI		2	5	\$3,975.95			\$3,975.95				*****
C MIAMI			5	\$3,975.95			\$3,975.95				*****
E DENVER		2	25	\$7,297.51			\$7,297.51				*****
E DENVER			25	\$7,297.51			\$7,297.51				*****
			30	\$11,273.46		J.	\$11,273.46				*****

**A.**

**STRUCT3:**

Displays the entities within the specified accounting level and their associated charges covered by the invoice.

**B.**

**PERIOD:**

Shows the period in which the charges were accrued.

**C.**

**COUNT:**

Displays the number of records used in the calculation.

**D.**

**CHARGE:**

Displays the charges for the accounting structures printed at the top of the invoice.

**E.**

**CREDIT:**

When applicable, displays an amount that adjusts the final charge.

**F.**

**DEBIT:**

When applicable, displays an amount that adjusts the final charge.

**G.**

**ADJUSTED CHARGE:**

Displays the final charge after all debits and credits have been taken into consideration.

**H.**

**BUDGET:**

Displays the budget value for the entity and period printed in columns A and B.

**I.**

**PERCENT BUDGET:**

Displays the percentage of the entity's budget used, after adjustments are applied.

**J.**

**Total**

Displays the totals for each column containing numeric information.

## Generating the General Ledger Interface File

Member CAKRGLIC in the CAJRJCL library executes the CAKSEAR2 procedure in order to produce the General Ledger interface file from the CCCTAB Table.

The CA Earl source statements and copy members required for the generation of the General Ledger file reside in the CAJREARL library downloaded during installation. The CAKRGLI program generates a file for input into the Masterpiece General Ledger system that can be easily modified to create records for other General Ledger systems.

**Note:** You must customize the CAKRGLI program to reflect your accounting structure and to decode CA PMA Chargeback accounting structures to General Ledger format account codes.

You should execute this jobstream **after** all data from a period has been processed (CAKRLOAD) and **after** completion of summary processing (CAKRSUM).

### CAKRGLIC JCL

```
//CAKRGLIC JOB (ACTINFO), 'PMGR', CLASS=A, MSGCLASS=X,
//*
//*****
//* SAMPJCL TO CREATE CA PMA Chargeback GENERAL LEDGER
//* INTERFACE FILE.
//* INSTRUCTIONS:
//* 1. THIS JCL USES THE CAKSEAR2 PROC PROVIDED IN
//*   THE SAMPJCL. EITHER COPY THE PROC TO THIS JCL OR
//*   ADD TO YOUR USER PROCLIB. CUSTOMIZE THE PROC TO
//*   REFLECT THE CORRECT HIGH LEVEL QUALIFERS.
//* 2. MODIFY THE JOB CARD ACCORDING TO YOUR INSTALLATION
//*   STANDARDS.
//* 3. ENSURE THAT THE SYSIN DD STATEMENT IS CHANGED TO
//*   REFLECT THE CORRECT HIGH LEVEL QUALIFIER.
//* 4. TO PROCESS EXAMPLE 1 - USE THE SYSIN DD WITH CAJREARL
//*   (CAKRGLI).
//* 7. IF CUSTOMIZATION IS REQUIRED, COPY THE PROVIDED
//*   CAJREARL MEMBERS TO NEW MEMBER(S). THEN CUSTOMIZE
//*   THE NEW MACLIB MEMBER(S).
//*****
//*
//Earl      EXEC CAKSEAR2
//SYSEarl   DD SYSOUT=*
//SYSIN     DD DSN=&INDEX. .CAJREARL(CAKRGLI), DISP=SHR
//*
```

## The CAKSEAR2 Procedure

This example uses CAJRJCL member CAKRGLIC to generate a detail invoice using **only** data from the CCCTAB.

```

/*****
/*
/* PROCEDURE CAKSEAR2
/* USE FOR CREATING THE GENERAL LEDGER INTERFACE FILE.
/*
/* MODIFICATIONS:
/* 1. UPDATE THE INSTREAM PROCEDURE PER THE INSTALLATION WORKSHEET.
/* 2. IF YOUR DATABASE IS DB2, REMOVE THE Datacom LIBRARIES AND
/*    UNCOMMENT THE DB2 LIBRARY.
/* 3. BE SURE TO CUSTOMIZE THE PARM STATEMENT AS FOLLOWS
/*
/*     PARM='SSID=DB23      ,
/*           PMA/CB,
/*           001,
/*           01,
/*           050191'
/*
/*     WHERE SSID   = DB23 FOR DB2 USERS OR THE OWNERS ID FOR Datacom
/*           PMA/CB = THE 6 CHARACTER JOURNAL ENTRY NAME
/*           001    = THE PERIOD FROM THE PMA DATABASE TO PROCESS
/*           01     = THE PERIOD TO BE ASSIGNED TO JOURNAL ENTRIES
/*           050191 = THE DATE TO BE ASSIGNED TO JOURNAL ENTRIES
/*
/* NOTE: YOU MAY MOVE THIS PROCEDURE TO A PROCLIB, OR USE IT
/*       INSTREAM.
/*
/*****
//CAKSEAR2 PROC INDEX='CAI',          /* DATA SET HIGH LEVEL QUALIFIER
//      DCIND 'CAI',                /* DATACOM HIGH LEVEL QUALIFIER
//      SYSOUT='*',                 /* SYSOUT CLASS
//      DVOL='XXXXXX',              /* OUTPUT FILE VOLUME
//      WORK='SYSDA'                 /* UNIT NAME FOR TEMP DATA SETS
//EarL  EXEC PGM=EarL,PARM='SSID=DB23      ,PMA/CB,001,01,050191'
//STEPLIB DD DISP=SHR,DSN=&INDEX..CAJRLOAD
//        DD DISP=SHR,DSN=&INDEX..CAICICS
//        DD DISP=SHR,DSN=&DCIND..USERLOAD      <--- Datacom LIBRARY
//        DD DISP=SHR,DSN=&DCIND..INFOCAI.LOAD  <--- Datacom LIBRARY
//        DD DISP=SHR,DSN=&DCIND..LOAD          <--- Datacom LIBRARY
/*      DD DISP=SHR,DSN=SYS2.DSNLOAD          <--- DB2 LIBRARY
//EarLLIB DD DISP=SHR,DSN=&INDEX..CAJREARL
/*
//CAIKRGL1 DD DSN=&INDEX..GENERAL.LEDGER,
//          UNIT=&WORK.,DISP=(NEW,CATLG,KEEP),
//          SPACE=(CYL,(1,1)),VOL=SER=&DVOL.,
//          DCB=(RECFM=FB,LRECL=100,BLKSIZE=4000)

```

```
//CAIKSPAR DD DISP=SHR,DSN=&INDEX..CAIKSPAR
//SYSPRINT DD SYSOUT=&SYSOUT.
//SYSOUT DD SYSOUT=&SYSOUT.
//SYSUDUMP DD SYSOUT=&SYSOUT.
//SORTMSG DD SYSOUT=&SYSOUT.
//SYSEarL DD SYSOUT=&SYSOUT.
//EarLOBJ DD UNIT=&WORK.,SPACE=(CYL,(10,5))
//WORK1 DD UNIT=&WORK.,SPACE=(CYL,(1,1))
//SYSUT1 DD UNIT=&WORK.,SPACE=(CYL,(1,1))
//SYSUT2 DD UNIT=&WORK.,SPACE=(CYL,(1,1))
//SYSUT3 DD UNIT=&WORK.,SPACE=(CYL,(1,1))
//SYSUT4 DD UNIT=&WORK.,SPACE=(CYL,(9,1))
//SYSUT5 DD UNIT=&WORK.,SPACE=(CYL,(9,1))

//SYSUT6 DD UNIT=&WORK.,SPACE=(CYL,(9,1))
//SORTIN DD DSN=&.&TMPFL1.,UNIT=SYSSQ,DISP=(NEW,DELETE),
// SPACE=(CYL,(10,1))
//SORTOUT DD DSN=&.&TMPFL2.,UNIT=SYSSQ,DISP=(NEW,DELETE),
// SPACE=(CYL,(10,1))
//SORTWK01 DD UNIT=SYSSQ,SPACE=(TRK,(100))
//SORTWK02 DD UNIT=SYSSQ,SPACE=(TRK,(100))
//SORTWK03 DD UNIT=SYSSQ,SPACE=(TRK,(100))
```

## Using CAKRINST as a Utility Program

The CAKRINST program is more than an installation vehicle for CA PMA Chargeback and DataManager. It is a general purpose SQL execution program. This program gives experienced SQL users a way to modify PMA tables very quickly. However, this program bypasses CA PMA Chargeback and DataManager's normal verification and validation processes.

## Setting Up Security Views on CCCTAB

One example of CAKRINST usage is for the establishing of user security. The online query system can be used to access information from the CCCTAB and CCCMOD tables. These tables contain *live* charge information. It is likely that certain users will be required to have access to certain charges, perhaps based on the contents of an accounting structure. Such access can be implemented very easily using the CAKRINST program.

The original SQL statement used to give a user access to the CCCTAB table is:

```
CREATE SYNONYM CCCTAF FOR OWNER.CCCTAB
```

The online system accesses the table using the synonym CCCTAF. To implement a security rule allowing access to **only** the RESTON records we would use CAKRINST to execute the following:

```
DELETE SYNONYM CCCTAF;  
CREATE VIEW CCCTAF AS SELECT * FROM OWNER.CCCTAB  
WHERE STRUCT1 = 'RESTON';
```

Thus, when the online system accesses the table via the name CCCTAB, only RESTON records are made available.

**Caution** Great care should be taken when using CAKRINST in this way, since **no** validation/verification of the statements is made.



# Chapter 12: CA PMA Chargeback Security and Audit

---

## Introduction

Security for DataManager relies upon CA Top Secret, CA ACF2, or IBM's RACF external security package. Security for all DataManager components must be defined with one of the above packages.

The security administrator is responsible for defining and implementing all security in DataManager. Users cannot implement security from DataManager.

This chapter provides system administrators with information for setting up security for CA Top Secret, CA ACF2, or RACF. Refer to the section that applies to the security used by your installation.

## CA Top Secret Security

Classes used by DataManager must be defined to CA Top Secret. This allows CA Top Secret to process security calls from DataManager.

New classes are defined to CA Top Secret by adding them to the Resource Definition Table (RDT) via the TSS command. Once added, they are immediately accessible. No restart, reinitialization, or IPL is required.

The new classes and their associated access levels for DataManager are:

<b>DataManager Component</b>	<b>Security Class</b>	<b>Access Levels</b>
Dialog	ACDIALOG	READ and WRITE
Panel	ACPANEL	READ and WRITE
SQL	ACSQL	READ and WRITE

**Note:** Tables, views, indexes, etc., are controlled by the database security. If you *do* have a security package that controls database objects, you must set up security according to the rules of the security package.

You can list your current RDT via the TSS LIST(RDT) command to verify that these classes are not already defined. If they are defined, you may proceed with protecting and permitting these new resources.

To add these classes, you must select eight unused resource codes. These codes must be in the hexadecimal range from 01 to 3F.

The following sample commands show the exact TSS command syntax for defining these new classes. In these examples, the resource codes of 38 through 3F have been selected.

To add resource class:

```

ACDIALOG    TSS ADDTO(RDT) RESCLASS(ACDIALOG) RESCODE(3A) -
              ATTR(LONG) DEFACC(READ=20)
ACPANEL     TSS ADDTO(RDT) RESCLASS(ACPANEL) RESCODE(3D) -
              ACLST(READ=20,WRITE=40,ALL,NONE) -
              ATTR(LONG) DEFACC(READ=20)
ACSQ        TSS ADDTO(RDT) RESCLASS(ACSQ) RESCODE(3F) -
              ACLST(READ=20,WRITE=40,ALL,NONE, ) -
              ATTR(LONG) DEFACC(READ=20)
    
```

## CA ACF2 Security

Resource types used by DataManager must be defined to CA ACF2. This allows CA ACF2 to process security calls from DataManager.

The new resources and their associated DataManager components are:

DataManager Component	Resource
Dialog	ACD
Panel	ACP
SQL	ACS

**Note:** Tables, views, indexes, etc., are controlled by the database security. If you *do* have a security package that controls database objects, you must set up security according to the rules of the security package.

## RACF Security

Classes used by DataManager must be defined to RACF. This allows RACF to process security calls from DataManager.

New classes are defined to RACF by adding them to the RACF resource list.

The new classes and their associated access levels for DataManager are:

<b>DataManager Component</b>	<b>Security Class</b>	<b>Access Levels</b>
Dialog	ACDIALOG	READ and WRITE
Panel	ACPANEL	READ and WRITE
SQL	ACSQL	READ and WRITE

**Note:** Tables, views, indexes, etc., are controlled by the database security. If you *do* have a security package that controls database objects, you must set up security according to the rules of the security package.

## Implementing Security for the CA PMA Chargeback Query System

Some users may wish to limit access to the CCCTAB table to specific records. The following discussion tells you how to perform the implementation for this feature.

Access to the CCCTAB table is handled via a synonym called CCCTAF. This synonym is created during the process of granting a user access to the tables. To implement specific record security this synonym must be replaced with a view. The CAKRINST program may be used for this purpose.

For example, you want user ABCD01 to have access only to records where DEPARTMENT is WEST. The DEPARTMENT is defined as the first level in the accounting structure.

We would change member CAKR84 from:

```
CREATE SYNONYM CCCTAF FOR OWNER.CCCTAB
          TO
CREATE VIEW CCCTAF AS SELECT * FROM OWNER.CCCTAB
WHERE STRUCT1 = 'WEST'
```

Then, user ABCD01 should run member CAKR84 which included input member CAKR84.

This ensures when user ABCD01 accesses the CCCTAB table, only records for WEST are made available due to the view.

**Note:** If the synonym has already been created, then the statement "DROP SYNONYM CCCTAF;" must be executed before the creation of the view.

To use the CAKRINST program, simply add a PDS member with the required SQL statements and point the CAKRINST program to this PDS member as input.

# Appendix A: CA PMA Chargeback Tables

---

The following table descriptions are presented in alphabetical order. Each table description consists of:

- the field names that make up the table
- the data type for each field name
- the length of each field name

An asterisk is displayed preceding the field-names which together make up the key of the table. (The key uniquely identifies each record in the table.)

## ACCSRTAB (Accounting Sources Table)

The ACCSRTAB table contains the information required to define sources for each accounting structure level. For each type of record used by the CA PMA Chargeback application, there exists an ACCSRTAB record, detailing the sources of each entry in the ACCSTTAB record and optional lookup table names.

Key	Field-Name	Type	Length
*	VERSION	CHAR	4
*	ORDID	CHAR	3
*	XSTRUCT	CHAR	16
	STRUCTL	CHAR	2
	SOURCE1	CHAR	16
	BEGIN1	CHAR	2
	LENGTH1	CHAR	2
	SOURCE2	CHAR	16
	BEGIN2	CHAR	2
	LENGTH2	CHAR	2
	SOURCE3	CHAR	16
	BEGIN3	CHAR	2
	LENGTH3	CHAR	2
	LOOKUP	CHAR	8

## ACCSTTAB (Accounting Structure Table)

This table defines the organizational hierarchy to be maintained on the CA PMA Chargeback database. This table along with the ACCSR TAB, ACCTLOOK, and PERTAB definition tables are used to create the CA PMA Chargeback construct.

Another purpose is to allow the CA PMA Chargeback application to report in *user* terms. The table simply contains the names, types, and lengths of up to 5 accounting levels such as DIVISION, DEPARTMENT, and GROUP-ID.

Key	Field-Name	Type	Length
*	VERSION	CHAR	4
	STRUCT1	CHAR	16
	STRUCT1L	CHAR	2
	STRUCT2	CHAR	16
	STRUCT2L	CHAR	2
	STRUCT3	CHAR	16
	STRUCT3L	CHAR	2
	STRUCT4	CHAR	16
	STRUCT4L	CHAR	2
	STRUCT5	CHAR	16
	STRUCT5L	CHAR	2

## ACCTLOOK (Lookup Table)

This table associates raw accounting entity values with meaningful organizational names.

Key	Field-Name	Type	Length
	VERSION	CHAR	4
	LOOKNAME	CHAR	8
	SEQNUM	INT	4
	ACCTFROM	CHAR	25
	ACCTTO	CHAR	25
	ACCTRET	CHAR	16

## BUDTAB (Budget Table)

This table is used in conjunction with the CCCTAB table. It contains budget information that is entered online via the Budgets facility and is immediately available via the Query facility. This information is also used for invoice generation.

Key	Field-Name	Type	Length
*	VERSION	CHAR	8
*	ORDID	CHAR	3
*	PERIOD	INT	4
*	PERIODB	INT	4
	ELEMENT	CHAR	16
	QUAL	CHAR	16
	AMOUNT	DEC	15 (scale 5)
	FLAGS	CHAR	2
*	DESCRIPT	CHAR	20
*	STRUCT1	CHAR	16
*	STRUCT2	CHAR	16
*	STRUCT3	CHAR	16
*	STRUCT4	CHAR	16
*	STRUCT5	CHAR	16

## CCCMOD (The 'Scratchpad' Table)

This table mirrors the CCCTAB table in format. It is used by the Period functions to generate forecasts and to determinate rates and the Query function for displaying data. It exists so that these calculations are not applied directly to the *live* CCCTAB table. Thus, the integrity of the CCCTAB table is preserved. This table can be generated online through Period Processing or by the batch Forecast job stream.

## CCCTAB (Consolidated Calculated Charges Table)

This table contains the information used by **all** CA PMA Chargeback functions. It is created and maintained by the **Detail** (batch) functions and is a summary table of the output records' processed data. Each item kept in the CCCTAB table is a line item on an invoice. The table is maintained with a unique key comprised of the Accounting Structure, Period, Charge Element, and Qualifier. Information includes:

- Number of units
- Rate
- Charge
- Number of ORD records that constitute each CCCTAB record

The CCCTAB table is the **principal** CA PMA Chargeback information database.

Key	Field-Name	Type	Length
*	VERSION	CHAR	8
*	ORDID	CHAR	3
*	PERIOD	INT	4
*	PERIODB	INT	4
*	ELEMENT	CHAR	16
*	QUAL	CHAR	16
*	MODIFIER	CHAR	16
	CNT	INT	4
	UNITS	DEC	15 (scale 0)
*	RATE	DEC	15 (scale 0)
	CHARGE	DEC	15 (scale 0)
+	FLAGS	CHAR	2
*	STRUCT1	CHAR	16
*	STRUCT2	CHAR	16
*	STRUCT3	CHAR	16
*	STRUCT4	CHAR	16
*	STRUCT5	CHAR	16

+ Split or Mod

## CHOPTAB (Shift Chopper Definition Table)

This table defines the times at which records associated with long running tasks are to be chopped and prorated. For example, when using algorithms to associate a rate with a charge unit for a charge element, it is quite normal to use a time in the qualification. When an ORD record spans a qualifying time, a condition arises that can lead to unfair allocation of charges. For example, if a job starts in PRIME shift (the most expensive) but spends most of its time in NON PRIME (cheaper) and is charged PRIME--this could be considered unfair. The purpose of a Shift Chop is to, in the above case, create two prorated records: the first completely in PRIME, the second completely in NON PRIME. This, provides equitable charge generation.

Key	Field-Name	Type	Length
*	VERSION	CHAR	8
	SPLIT1	CHAR	4
	SPLIT2	CHAR	4
	SPLIT3	CHAR	4
	SPLIT4	CHAR	4

## DBCRTAB (Credit and Debit Table)

This table is used in conjunction with the CCCTAB table. It contains credit and debit manual adjustments that are entered online via the Data Entry facility and are immediately available via the Query facility. This information is also used for invoice generation.

Key	Field-Name	Type	Length
*	VERSION	CHAR	8
*	ORDID	CHAR	3
*	PERIOD	INT	4
*	PERIODB	INT	4
	ELEMENT	CHAR	16
	QUAL	CHAR	16
	CRAMOUNT	DEC	15 (scale 5)
	DBAMOUNT	DEC	15 (scale 5)
	FLAGS	CHAR	2
*	DESCRIPT	CHAR	20
*	STRUCT1	CHAR	16
*	STRUCT2	CHAR	16
*	STRUCT3	CHAR	16
*	STRUCT4	CHAR	16
*	STRUCT5	CHAR	16

## ELEMTAB (Charge Element Definition Table)

this table defines the elements used to calculate default charge element values. For example a batch job ORD may have CPUCHARGE, DISKCHARGE, and TAPECHARGE charge elements. The **default charge** calculation for each element is defined in this table. However, special handling routines, or **algorithms**, are defined elsewhere. A charge element may also have an associated *complex unit*, as well as a set of algorithms. If a charge element is defined, then a specific record is created during the Detail Function process. Conversely, if no definition exists, then no record is generated and the item is never created.

Key	Field-Name	Type	Length
*	VERSION	CHAR	8
*	ORDID	CHAR	3
*	ELEMENT	CHAR	16
	UNIT	CHAR	16
	NORMAL	CHAR	16
	DEFRATE	DEC	15 (scale 0)
	MINCHG	DEC	15 (scale 0)
	MAXCHG	DEC	15 (scale 0)
	COST: (See note)	DEC	15 (scale 0)

**Note:** For Future Use

## MODTAB (Charge Modifier Table)

This table defines conditions that modify the calculated charges for reasons such as vacation discounts, priority weighting, class weighting and so forth.

A condition is specified, as well as a *modifier*. This takes the form of either an amount, or a percentage. If the condition is found to be true, then the modifier is applied to the calculated charge. This table contains modifier definitions.

Key	Field-Name	Type	Length
*	VERSION	CHAR	8
*	ORDID	CHAR	3
*	MODIFIER	CHAR	16
	ELEMCRIT	CHAR	16
	QUALCRIT	CHAR	16
	ST1CRIT	CHAR	16
	ST2CRIT	CHAR	16
	ST3CRIT	CHAR	16
	ST4CRIT	CHAR	16
	ST5CRIT	CHAR	16
	MODAMT	DEC	15 (scale 0)
	MODFLAG	CHAR	1
	MODEOT	CHAR	1
	MODQUAL	CHAR	16
	SEQNO	INT	4

## NORMTAB (Unit Normalization Table)

This table Defines a normalization or weighting factors to be applied when calculating charge unit values. It may be the case, in a multiprocessing environment, that you require the ability to normalize certain data such as CPU timings. The NORMTAB is linked to the charge element, even though the Normalization Factor is applied to the calculated unit. You specify a field name to be tested, a condition to be checked, and a factor to be applied to the calculated charge unit.

Key	Field-Name	Type	Length
*	VERSION	CHAR	8
*	ORDID	CHAR	3
*	NORMAL	CHAR	16
*	NORMQUAL	CHAR	16
	FACTOR	DEC	15 (scale 0)
	NORMFLAG	CHAR	1
	SEQNO	INT	4

## OPTTAB (Option Settings Definition Table)

This table defines user options, by userid, so that each user's settings can be saved individually.

Key	Field-Name	Type	Length
*	USERID	CHAR	8
	MONIC	CHAR	3
	ACTBAR	CHAR	5
	MSGWRN	CHAR	3
	MSGINF	CHAR	3
	SOD	CHAR	4
	ALTPF	CHAR	3
	DBROWS	CHAR	6
	BASEVER	CHAR	4
	CBVER	CHAR	4

## PERTAB (Period Definition Table)

Chargeback is, as a task, performed continuously. However, actual invoicing is normally done on a fixed period basis. There is a requirement to maintain the charges on a periodic basis across the whole system. The purpose of the PERTAB is to define these fixed periods.

Key	Field-Name	Type	Length
*	VERSION	CHAR	4
*	PERIOD	INT	4
	END_DATE	CHAR	8
	END_TIME	CHAR	6

## QUALTAB (Algorithm Qualifier Definition Table)

This table defines Qualifier definitions that associate a qualifier to an algorithm.

**Note:** Algorithms are *owned* by charge elements, qualifiers are *owned* by no one.

Qualifiers are normally associated with an ORD record. A qualifier is simply a logical test to establish truth or falsehood.

Key	Field-Name	Type	Length
	VERSION	CHAR	8
	ORDID	CHAR	3
	QUAL	CHAR	16
	QLINK	CHAR	3
	QFIELD	CHAR	16
	QOPER	CHAR	2
	QCONS	CHAR	16
	SEQNO	INT	4

## QUERYTAB (Saved Query Definition Table)

This table defines queries which are stored by name, for later retrieval and use. This provides a way for nontechnicians to execute queries against the CCCTAB, CCCMOD, BUDTAB, and DBCRTAB tables for *on demand* reporting purposes.

Key	Field-Name	Type	Length
*	VERSION	CHAR	8
*	QNAME	CHAR	8
	SUMFLAG	CHAR	1
	BRFLAG	CHAR	1
	BDFLAG	CHAR	1
	ORDID	CHAR	3
	ORDID_B	CHAR	1
	ORDID_0	CHAR	1
	CNT	CHAR	16
	CNT_OP	CHAR	1
	CNT_S	CHAR	3
	ELEM	CHAR	16
	ELEM_B	CHAR	1
	ELEM_0	CHAR	1
	RATE	CHAR	16
	RATE_OP	CHAR	1
	RATE_S	CHAR	3
	QUAL	CHAR	16
	QUAL_B	CHAR	1
	QUAL_0	CHAR	1
	UNITS	CHAR	16
	UNITS_OP	CHAR	1
	UNITS_S	CHAR	3
	PER_FR	CHAR	4
	PER_TO	CHAR	4
	PER_B	CHAR	1
	PER_0	CHAR	1
	BUDAM	CHAR	16
	BUDAM_OP	CHAR	1
	BUDAM_S	CHAR	3
	ST1	CHAR	16
	ST1_B	CHAR	1
	ST1_0	CHAR	1
	BUDPC	CHAR	16
	BUDPC_OP	CHAR	1
	BUDPC_S	CHAR	3
	ST2	CHAR	16
	ST2_B	CHAR	1
	ST2_0	CHAR	1
	CHG	CHAR	16
	CHG_OP	CHAR	1

	CHG_S	CHAR	3
	ST3	CHAR	16
	ST3_B	CHAR	1
	ST3_0	CHAR	1
	DBAM	CHAR	16
	DBAM_OP	CHAR	1
	DBAM_S	CHAR	3
	ST4	CHAR	16
	ST4_B	CHAR	1
Key	Field-Name	Type	Length
	ST4_0	CHAR	1
	CRAM	CHAR	16
	CRAM_OP	CHAR	1
	CRAM_S	CHAR	3
	ST5	CHAR	16
	ST5_B	CHAR	1
	ST5_0	CHAR	1
	TOT	CHAR	16
	TOT_OP	CHAR	1
	TOT_S	CHAR	3
	DESC	CHAR	20
	DESCRIPT	CHAR	20

## RATETAB (Charge Algorithm Definition Table)

An algorithm is a formula that associates a rate with a qualifier. This table contains the **qualified** (conditional) rates.

Key	Field-Name	Type	Length
*	VERSION	CHAR	8
*	ORDID	CHAR	3
*	ELEMENT	CHAR	16
	SEQNO	INT	4
*	QUALNAME	CHAR	16
	RATE	DEC	15 (scale 0)
	COST: (See note)	DEC	15 (scale 0)

**Note:** For Future Use

## SPLITTAB (Split Resource Definition Table)

This table defines the conditions under which a charge associated with a given job or task executed on behalf of several users is split. The normal method is to allocate a fixed percentage of the charge to each user; the combined percentages total 100. This table maintains this information, and is used by the Detail functions to perform the split.

Key	Field-Name	Type	Length
*	VERSION	CHAR	8
*	ORDID	CHAR	3
*	SPLIT	CHAR	16
*	ST1CRIT	CHAR	16
*	ST2CRIT	CHAR	16
*	ST3CRIT	CHAR	16
*	ST4CRIT	CHAR	16
*	ST5CRIT	CHAR	16
	PERCENT	DEC	15 (scale 0)

## SUMTAB (Summary Function Definition Table)

this table defines what records are to be selected at the end of a period. Summary functions are concerned with calculations that can only be made at the end of a period. These fall into two categories: Cost Recovery and Overhead Allocation. In each case, a given set of records (which may be ALL records) from the CCCTAB file are selected. New records are added to the CCCTAB file detailing the modified charges, in both cases.

Key	Field-Name	Type	Length
*	VERSION	CHAR	8
*	RULENAME	CHAR	16
*	ORDID	CHAR	3
	STRUCT1	CHAR	16
	STRUCT2	CHAR	16
	STRUCT3	CHAR	16
	STRUCT4	CHAR	16
	STRUCT5	CHAR	16
	ELEMENT	CHAR	16
	QUAL	CHAR	16
*	PERIOD	INT	4
	SRC_ORDID	CHAR	3
	SRC_ELEMENT	CHAR	16
	SRC_AMOUNT	DEC	15

## UNITTAB (Charge Unit Definition Table)

This table defines the formula to be used when calculating charge unit values. A *charge unit* can be calculated via any mathematical formula based on the contents of an ORD element or a combination of two or more existing ORD elements.

Key	Field-Name	Type	Length
	VERSION	CHAR	8
	ORDID	CHAR	3
	UNIT	CHAR	16
	ULINK	CHAR	1
	UFIELD	CHAR	16
	UOPER	CHAR	1
	UCONS	CHAR	16
	SEQNO	INT	4

**Note:** For information on how to get a hard copy of these tables, see your Database Administrator.



# Appendix B: CA PMA Chargeback Panel Displays: Monochrome vs. Color

---

The following table summarizes the colors and intensities, by panel element, used by CA PMA Chargeback when displaying panels on non-programmable color and monochrome terminals.

## Action Bar and Pull-Down

Panel Element	ColorTerminal	Monochrome Terminal
Background	Black	Black
Choices	White	White
Mnemonics	Underscore	Underscore

## Panel Body

Panel Element	ColorTerminal	Monochrome Terminal
Background	Black	Black
Protected Information		
Panel Titles	Yellow	High intensity
Panel ID	Blue	Normal intensity
Instructions	Turquoise	Normal intensity
Field Prompts	Turquoise	Normal intensity
Brackets	Turquoise	Normal intensity
Column Headings	Turquoise	High intensity
Group Headings	Turquoise	Normal intensity
Normal Text	Turquoise	Normal intensity
Emphasized Text	Yellow	High intensity
Entry Field Underscore		
Normal Input	Green	Normal intensity
Emphasized Input	Yellow	High intensity
Panel Element	ColorTerminal	Monochrome Terminal
Choices	White	Normal intensity
Unavailable Choices	Blue	Asterisk (*)
Mnemonics	Underscore	Underscore
Entry Field Content		
Normal Input	Green	Normal intensity
Emphasized Input	Yellow	High intensity
Scrolling Information	Blue	Normal intensity
Separator Line	Turquoise	Normal intensity
Pop-up Window Border	Turquoise	Normal intensity

**Function Key Area**

<b>Panel Element</b>	<b>ColorTerminal</b>	<b>Monochrome Terminal</b>
Background	Black	Black
Choices	Blue	Normal

**Selection Emphasis**

<b>Panel Element</b>	<b>ColorTerminal</b>	<b>Monochrome Terminal</b>
Selection Cursor		
Choices	Text cursor	Text cursor
Entry Field	Text cursor	Text cursor in field
Selected Emphasis	Yellow	Reverse color
Selected/Cursored	Yellow/Text cursor	Reverse color

**Error Emphasis**

<b>Panel Element</b>	<b>ColorTerminal</b>	<b>Monochrome Terminal</b>
Error Emphasis	Red	Reverse

**Messages**

<b>Panel Element</b>	<b>ColorTerminal</b>	<b>Monochrome Terminal</b>
<b>Notification</b>		
Background	Black	Black
Foreground	White	High intensity
<b>Warning</b>		
Background	Black	Black
Foreground	Yellow	High intensity
<b>Critical</b>		
Background	Black	Reverse/Highlight
Foreground	Red	Reverse/Highlight

# Glossary

---

## **action bar**

Appears at the top of a panel; it gives you access to a group of actions that CA PMA Chargeback supports. The action bar contains a list of keyword choices.

Press F10 to activate the action bar. Then tab to the keyword of your choice and press Enter. When you make a selection, a pull-down menu appears that lists available options.

## **action bar pull-down**

An extension of the action bar that displays a list of options available for the selected action bar choice. The pull-down appears after you make an action bar selection. Additional pop-up windows may appear from pull-down choices to further extend the actions available to you.

## **action codes**

Numbers and mnemonics assigned to actions in a **list** panel.

## **algorithm**

A series of steps that yield a result (usually a repetitive process). In this case, the formula for calculating charges for resource usage using CA PMA Chargeback.

## **application**

A collection of software components that you purchase and install to perform specific types of work on a computer. In other words, the reason programs are written. For example, a payroll application or a chargeback application.

## **audit facility**

An operating system service which reviews and examines the activities of the system. Its purpose is to test data security and data integrity procedures.

## **batch processing**

A method of processing large amounts of data at one time for jobs too large to execute immediately online. Such jobs do not involve user interaction.

## **CA EARL**

Easy Access Report Language. An optional facility which can be used to generate reports.

## **cancel**

An action that removes the current panel without processing it and returns you to the previous panel.

---

**catalog**

A file the computer system maintains as a directory index to the system's files, similar to the card catalog of a standard library.

**centralized database**

A systemized collection of data for access by a variety of applications that is centrally located.

**charge element**

A user-defined element that holds the **result** of a chargeback algorithm (the charge).

**charge unit**

Defines a chargeable resource. A charge unit can be either:

- **Simple:** A numeric field from the incoming ORD record that is used in the chargeback algorithm. Any numeric field in the incoming ORD record can be designated as a charge unit, and thus charged for.
- **Complex:** a user-defined name calculated from two or more existing ORD fields or other complex units.

**chargeback**

The process of measuring, recording, charging for, and reporting resource usage by cost center.

**column**

A vertical list of values in a table that correspond to one field. Not a *row*.

**command input area**

Preceded by the **screens** ==> indicator on an online data entry panel. Used to enter commands, link, transfers, prompts.

**commit**

An indication in an application program that a section of work is done and that the data it has modified or created is consistent and complete.

**conditional execution**

Only some of the steps in a procedure are executed depending on the conditions at the time of the execution.

**conditional expansion**

Only some of the steps in a procedure are retrieved and expanded depending on the conditions at the time of the expansion.

**construct**

An identifier that is added by an application.

**control field**

A portion of records you designate, which are used by the program to sort or merge records into a specific sequence.

---

**control parameters**

Parameters which are generally governed by their installation defaults and will only need to be specified in special cases.

**control statement**

A list of keywords that determine what a batch job will do. Defaults are usually defined during installation.

**cost recovery**

A method for recovering a specified dollar amount for a designated resource from the accounting entities that used the resource.

**data definition table**

See definition tables.

**data dictionary**

A definition of the database files and fields and their attributes.

**data normalization**

The process of removing any potential problems from the design of a relational database.

**data reduction**

The transformation of raw data into a more useful and compressed form.

**data set**

A group of logically related records stored together and given a unique name.

**data table**

Database tables that contain data used or produced by an application.

**database**

(See also **relational database** )

A systemized collection of data stored for immediate access.

A set of data consisting of at least one file, sufficient for a given purpose or for a given data processing system.

**Database Administrator (DBA)**

A person who is responsible for a database system, particularly for the rules by which data is accessed and stored. The DBA is usually responsible also for database integrity, security, performance, and recovery.

**database archival**

Periodic backups of the database as protection against media failure or for future reference.

---

**database load**

Transferring data to the database for processing.

**definition tables**

Tables that contain primarily user-defined input which defines the actual CA PMA Chargeback processing environment and controls the logic of the system.

**development version**

The version you can edit. See **commit processing**.

**diagnostic message**

A message displayed and/or printed by CA PMA Chargeback when it detects an error during execution.

**display keys**

A common dialog action that lets you choose the way function key area will be displayed. Options include: long form, short form, or not at all.

**element**

The space reserved for a data value on a panel. Where CA PMA Chargeback displays data or accepts input. Also see **charge element**.

**enter**

A user action that:

- Submits panel information to the computer for processing
- Tells the computer to perform selected actions on specific objects
- Implies selection of an item

**entry panel**

A specific panel type containing one or more entry fields (and optionally selection fields and protected information such as headings, prompts, and explanatory text).

**exit**

An action that terminates the current panel and returns you to a higher level panel. Repeated exit requests return to the highest level in the panel hierarchy.

**fast path**

An interaction technique that is faster than the usual interaction for moving through panels. This can include typing the number of a choice or using mnemonics.

**field**

What input and output record layouts consist of. The definition of data values aligned in a column within a table.

**function key**

A key that causes a specified sequence of operations to be performed when it is pressed. Function keys are usually labeled Fn.

---

**generic selection**

Allows you to display, list or analyze a group of records, tables, or jobs whose names begin with the same characters by coding the common characters with a special character (usually the percent sign).

**global parameters**

A variable that can be set to an arithmetic, binary, or character value and used as a predecessor condition.

## Appendix C: Glossary

---

**action bar**

Appears at the top of a panel; it gives you access to a group of actions that CA PMA Chargeback supports. The action bar contains a list of keyword choices.

Press F10 to activate the action bar. Then tab to the keyword of your choice and press Enter. When you make a selection, a pull-down menu appears that lists available options.

**action bar pull-down**

An extension of the action bar that displays a list of options available for the selected action bar choice. The pull-down appears after you make an action bar selection. Additional pop-up windows may appear from pull-down choices to further extend the actions available to you.

**action codes**

Numbers and mnemonics assigned to actions in a **list** panel.

**algorithm**

A series of steps that yield a result (usually a repetitive process). In this case, the formula for calculating charges for resource usage using CA PMA Chargeback.

**application**

A collection of software components that you purchase and install to perform specific types of work on a computer. In other words, the reason programs are written. For example, a payroll application or a chargeback application.

**audit facility**

An operating system service which reviews and examines the activities of the system. Its purpose is to test data security and data integrity procedures.

**batch processing**

A method of processing large amounts of data at one time for jobs too large to execute immediately online. Such jobs do not involve user interaction.

---

**CA EARL**

Easy Access Report Language. An optional facility which can be used to generate reports.

**cancel**

An action that removes the current panel without processing it and returns you to the previous panel.

**catalog**

A file the computer system maintains as a directory index to the system's files, similar to the card catalog of a standard library.

**centralized database**

A systemized collection of data for access by a variety of applications that is centrally located.

**chargeback**

The process of measuring, recording, charging for, and reporting resource usage by cost center.

**charge element**

A user-defined element that holds the **result** of a chargeback algorithm (the charge).

**charge unit**

Defines a chargeable resource. A charge unit can be either:

- **Simple:** A numeric field from the incoming ORD record that is used in the chargeback algorithm. Any numeric field in the incoming ORD record can be designated as a charge unit, and thus charged for.
- **Complex:** a user-defined name calculated from two or more existing ORD fields or other complex units.

**column**

A vertical list of values in a table that correspond to one field. Not a *row*.

**command input area**

Preceded by the **screens** ==> indicator on an online data entry panel. Used to enter commands, link, transfers, prompts.

**commit**

An indication in an application program that a section of work is done and that the data it has modified or created is consistent and complete.

**conditional execution**

Only some of the steps in a procedure are executed depending on the conditions at the time of the execution.

---

**conditional expansion**

Only some of the steps in a procedure are retrieved and expanded depending on the conditions at the time of the expansion.

**construct**

An identifier that is added by an application.

**control field**

A portion of records you designate, which are used by the program to sort or merge records into a specific sequence.

**control parameters**

Parameters which are generally governed by their installation defaults and will only need to be specified in special cases.

**control statement**

A list of keywords that determine what a batch job will do. Defaults are usually defined during installation.

**cost recovery**

A method for recovering a specified dollar amount for a designated resource from the accounting entities that used the resource.

**database**

(See also **relational database** )

A systemized collection of data stored for immediate access.

A set of data consisting of at least one file, sufficient for a given purpose or for a given data processing system.

**Database Administrator (DBA)**

A person who is responsible for a database system, particularly for the rules by which data is accessed and stored. The DBA is usually responsible also for database integrity, security, performance, and recovery.

**database archival**

Periodic backups of the database as protection against media failure or for future reference.

**database load**

Transferring data to the database for processing.

**data definition table**

See definition tables.

**data dictionary**

A definition of the database files and fields and their attributes.

---

**data normalization**

The process of removing any potential problems from the design of a relational database.

**data reduction**

The transformation of raw data into a more useful and compressed form.

**data set**

A group of logically related records stored together and given a unique name.

**data table**

Database tables that contain data used or produced by an application.

**definition tables**

Tables that contain primarily user-defined input which defines the actual CA PMA Chargeback processing environment and controls the logic of the system.

**development version**

The version you can edit. See **commit processing**.

**diagnostic message**

A message displayed and/or printed by CA PMA Chargeback when it detects an error during execution.

**display keys**

A common dialog action that lets you choose the way function key area will be displayed. Options include: long form, short form, or not at all.

**element**

The space reserved for a data value on a panel. Where CA PMA Chargeback displays data or accepts input. Also see **charge element**.

**enter**

A user action that:

- Submits panel information to the computer for processing
- Tells the computer to perform selected actions on specific objects
- Implies selection of an item

**entry panel**

A specific panel type containing one or more entry fields (and optionally selection fields and protected information such as headings, prompts, and explanatory text).

**exit**

An action that terminates the current panel and returns you to a higher level panel. Repeated exit requests return to the highest level in the panel hierarchy.

---

**fast path**

An interaction technique that is faster than the usual interaction for moving through panels. This can include typing the number of a choice or using mnemonics.

**field**

What input and output record layouts consist of. The definition of data values aligned in a column within a table.

**function key**

A key that causes a specified sequence of operations to be performed when it is pressed. Function keys are usually labeled Fn.

**generic selection**

Allows you to display, list or analyze a group of records, tables, or jobs whose names begin with the same characters by coding the common characters with a special character (usually the percent sign).

**global parameters**

A variable that can be set to an arithmetic, binary, or character value and used as a predecessor condition.

**input ID**

The unique code that occurs in the same place on all records of the same type.

**inquiry/update program**

A system application used to interrogate and update one or more tables the system maintains at the same time.

**installation option**

A value specified on the installation macro when the product is installed.

**IRD**

An acronym for Input Record Definition.

**key**

A data item that identifies a data record. For example, product key or customer key.

**keyword**

Choices within the action bar. Tab to a keyword and press Enter to perform that particular action.

**list panel**

A panel that displays a list of items from which you can select one or more items (choices) and then specify one or more actions to work on those choices.

**lookup table**

A CA PMA Chargeback option used to identify the specific entities within an accounting structure. The lookup name is stored within the database in a lookup table and is available for display when you do queries and print invoices and reports.

---

**maximum charge**

The maximum charge that can be assessed for a **charge element**. If the computed charge is greater than or equal to the maximum charge, the maximum charge will be applied.

**minimum charge**

The minimum charge that can be assessed for a **charge element**. If the computed charge is less than or equal to the minimum charge, the minimum charge will be applied.

**modifier**

A modifier is used to make special changes to a charge, such as discounts and so forth. A modifier takes the form of either an amount or a percentage. When a conditional test is applied and found to be true, the modifier is applied to the calculated charge (the charge element).

**normalizer**

Normalizers give you the ability to **weight** the value of a charge unit. Normalizer are numeric and frequently have qualifiers associated with them.

**offset**

Where the first character in a element is located within the record (the nth character position).

**online**

An interactive computer session run from a computer terminal. As opposed to *batch* and *offline*.

**ORD**

An acronym for Output Record Definition.

**panel ID**

A set of numbers and letters that identify an online product panel.

**period number**

Each database record is associated with a different time frame. Period number is the identifier used for each of these time frames.

**output record header**

Since DataManager outputs records for Performance Management and Accounting applications, duration of services is of primary importance. For this reason, every output record definition includes a header that specifies the ORD, a start stamp, stop stamp and duration.

**PMA**

An acronym meaning Performance, Measurement and Accounting.

**overhead allocation**

Distribution of charges for a shared or common resource.

---

**pop-up window**

A portion of a screen in which a small panel is displayed.

**Note:** You must finish interacting with a set of related pop-up windows before continuing with the base panel.

**precision**

The number of digits to the right of the decimal point.

**primary panel**

The first panel that appears when you run CA PMA Chargeback.

**production (PROD) version**

The data used to produce real invoices. As opposed to *test version* or *development version*.

**pull-down**

See **action bar pull-down**.

**qualified rate**

The rate that is selected for application to a unit based on a user-defined test (qualifier). A true or false condition based on the contents or range of a field.

**qualifier**

The name of a user-defined conditional test that is used in rate selection, as well as with normalizers and modifiers.

**reduction**

See **data reduction**.

**relational database**

A database that is organized and accessed according to relationships between data items. These relationships are expressed by means of tables of records and columns. Interdependencies among these tables are expressed by data values (rather than by pointers). Data items are accessed by matching values and not by following predefined paths-- the paths are established at the time of access. This allows a high degree of data independence.

**row**

A horizontal line of values in a table that correspond to one data record. Not a *column*.

**screen ID**

See panel ID.

**shift chop**

A CA PMA Chargeback option that allows equitable allocation and calculation of charges to ORD records that *span* shifts. This function creates multiple records from a single input. The interval chop routines are performed **before** creation of the CCC detail record, at ORD reception.

---

**scroll bar**

A line on some CA PMA Chargeback panels which gives you several ways to scroll records. For an explanation of how the scroll bar works, see Sample List Panel.

**SMF**

The acronym for IBM's System Management Facilities. You can adapt CA PMA Chargeback to process SMF data using customization.

**source record**

The record of origin.

**split charge**

CA PMA Chargeback enables you to split charges calculated for a specific accounting level across its entities. Split processing occurs **after** charges are calculated for a given Consolidated Calculated Charge (CCC). If the record is associated with a split, then the charge is prorated and new records are created.

**start and stop stamps**

The date and time fields stored on the ORD. This information specifies when the process described by this record began and ended.

**structure**

See **accounting structure**.

**suspend**

Stops processing a panel but leaves it on the terminal screen for easy reference. Then resumes running the preceding panel.

**table maintenance functions**

Acctdefs or Cbdefs options that allow you to update/modify definition tables.

**TEST version**

Allows you to experiment with CA PMA Chargeback without impacting your daily production processing.

**input ID**

The unique code that occurs in the same place on all records of the same type.

**inquiry/update program**

A system application used to interrogate and update one or more tables the system maintains at the same time.

**installation option**

A value specified on the installation macro when the product is installed.

**IRD**

An acronym for Input Record Definition.

---

<b>key</b>	A data item that identifies a data record. For example, product key or customer key.
<b>keyword</b>	Choices within the action bar. Tab to a keyword and press Enter to perform that particular action.
<b>list panel</b>	A panel that displays a list of items from which you can select one or more items (choices) and then specify one or more actions to work on those choices.
<b>lookup table</b>	A CA PMA Chargeback option used to identify the specific entities within an accounting structure. The lookup name is stored within the database in a lookup table and is available for display when you do queries and print invoices and reports.
<b>maximum charge</b>	The maximum charge that can be assessed for a <b>charge element</b> . If the computed charge is greater than or equal to the maximum charge, the maximum charge will be applied.
<b>minimum charge</b>	The minimum charge that can be assessed for a <b>charge element</b> . If the computed charge is less than or equal to the minimum charge, the minimum charge will be applied.
<b>modifier</b>	A modifier is used to make special changes to a charge, such as discounts and so forth. A modifier takes the form of either an amount or a percentage. When a conditional test is applied and found to be true, the modifier is applied to the calculated charge (the charge element).
<b>normalizer</b>	Normalizers give you the ability to <b>weight</b> the value of a charge unit. Normalizer are numeric and frequently have qualifiers associated with them.
<b>offset</b>	Where the first character in a element is located within the record (the nth character position).
<b>online</b>	An interactive computer session run from a computer terminal. As opposed to <i>batch</i> and <i>offline</i> .
<b>ORD</b>	An acronym for Output Record Definition.

---

**output record header**

Since DataManager outputs records for Performance Management and Accounting applications, duration of services is of primary importance. For this reason, every output record definition includes a header that specifies the ORD, a start stamp, stop stamp and duration.

**overhead allocation**

Distribution of charges for a shared or common resource.

**panel ID**

A set of numbers and letters that identify an online product panel.

**period number**

Each database record is associated with a different time frame. Period number is the identifier used for each of these time frames.

**PMA**

An acronym meaning Performance, Measurement and Accounting.

**pop-up window**

A portion of a screen in which a small panel is displayed.

**Note:** You must finish interacting with a set of related pop-up windows before continuing with the base panel.

**precision**

The number of digits to the right of the decimal point.

**primary panel**

The first panel that appears when you run CA PMA Chargeback.

**production (PROD) version**

The data used to produce real invoices. As opposed to *test version* or *development version*.

**pull-down**

See **action bar pull-down**.

**qualified rate**

The rate that is selected for application to a unit based on a user-defined test (qualifier). A true or false condition based on the contents or range of a field.

**qualifier**

The name of a user-defined conditional test that is used in rate selection, as well as with normalizers and modifiers.

**reduction**

See **data reduction**.

---

**relational database**

A database that is organized and accessed according to relationships between data items. These relationships are expressed by means of tables of records and columns. Interdependencies among these tables are expressed by data values (rather than by pointers). Data items are accessed by matching values and not by following predefined paths-- the paths are established at the time of access. This allows a high degree of data independence.

**row**

A horizontal line of values in a table that correspond to one data record. Not a *column*.

**screen ID**

See panel ID.

**scroll bar**

A line on some CA PMA Chargeback panels which gives you several ways to scroll records. For an explanation of how the scroll bar works, see Sample List Panel.

**shift chop**

A CA PMA Chargeback option that allows equitable allocation and calculation of charges to ORD records that *span* shifts. This function creates multiple records from a single input. The interval chop routines are performed **before** creation of the CCC detail record, at ORD reception.

**SMF**

The acronym for IBM's System Management Facilities. You can adapt CA PMA Chargeback to process SMF data using customization.

**source record**

The record of origin.

**split charge**

CA PMA Chargeback enables you to split charges calculated for a specific accounting level across its entities. Split processing occurs **after** charges are calculated for a given Consolidated Calculated Charge (CCC). If the record is associated with a split, then the charge is prorated and new records are created.

**start and stop stamps**

The date and time fields stored on the ORD. This information specifies when the process described by this record began and ended.

**structure**

See **accounting structure**.

**suspend**

Stops processing a panel but leaves it on the terminal screen for easy reference. Then resumes running the preceding panel.

---

**table maintenance functions**

Acctdefs or Cbdefs options that allow you to update/modify definition tables.

**TEST version**

Allows you to experiment with CA PMA Chargeback without impacting your daily production processing.

# Index

---

## %

%, wildcard search character • 29, 185

## \*

\*ONE\* usage, flat rate and surcharges • 140

## ?

? command • 31

## =

= command • 31

## A

About window (displays genlevel) • 31, 39, 379  
Accounting periods definition entry panel (CBAPER)  
• 89  
Accounting sources  
    creating a lookup table • 86, 87  
    defining • 81, 82  
with a Lookup Table • 82  
without a Lookup table • 81  
    examples • 81, 82, 86, 87  
defining a structure without a Lookup table • 81  
defining with a Lookup Table • 82  
lookup table • 86, 87  
    lookup insert panel (CBASRCI) • 83  
    lookup panel (CBASRCU) • 83  
    panels • 73, 75, 77, 78, 83  
Entry list (CBASRCE) • 78  
Expanded list (CBASRCX) • 77  
List (CBASRCL) • 75  
Lookup insert pop-up (CBASRCI) • 83  
Lookup panel (CBASRCU) • 83  
Primary (CBASRCP) • 73  
    table (ACCSRTAB) • 58, 473  
detail • 473  
overview • 58  
Accounting structure  
    defining • 67  
    panel (CBASTRE) • 69  
    table (ACCSTTAB) • 58, 474  
detail • 474  
overview • 58

ACCSRTAB (Accounting sources table)  
    detail • 473  
    overview • 58  
ACCSTTAB (Accounting structure table)  
    detail • 474  
    overview • 58  
Acctdefs • 18  
ACCTLOOK (Lookup table)  
    detail • 474  
    overview • 58  
Action bar  
    function key (F10) • 31, 55  
    function key (PA1) • 55  
    overview • 31  
    pull-downs • 35, 36, 37, 38  
Exit pull-down • 37  
Help pull-down • 38  
overview • 35  
Panel pull-down • 36  
Adjustments • 204  
Algorithm qualifier definition table (QUALTAB)  
    detail • 481  
    overview • 58  
Algorithms  
    calculating • 95  
    cost recovery • 203  
    examples • 106, 107, 114, 115, 121, 122, 128,  
        130, 133, 139, 140, 141, 182, 183, 184, 185,  
        203, 210, 211, 212  
cost recovery • 203, 210, 211  
defining a complex unit with a constant • 115  
defining a complex unit without a constant • 114  
defining a conditional rate • 121, 122  
defining a modifier • 182, 183, 184, 185  
defining a normalizer • 133, 139  
defining a qualifier • 128, 130  
defining flat rates • 140  
normalization of charge units • 107  
overhead distribution • 212  
preexisting charges • 141  
simple charge format • 106  
    logic used in calculations • 95  
    overview • 21, 94  
ALL as an ORD type • 29, 30  
Application construct definition • 67

---

Archive/Restore procedure (CAKSARES) • 397, 398  
Archive/Restore program (CAKSARCH) • 397  
Archiving tables • 399  
Are you sure? window • 371

## B

BACKUP control statement • 399  
BACKUP option • 399  
Batch Forecasting  
    CAKRFCST control statements • 428  
    control report • 434  
Batch functions, overview • 19  
Batch processing  
    invoicing • 453, 464  
    overview • 389  
    period close • 438  
    period open • 441  
    reconciliation reports • 446  
    summary functions • 435  
Batch reporting  
    Forecasting control report • 434  
    invoices • 453, 455, 458, 460, 462  
example 1 • 458  
example 2 • 460  
example 3 • 462  
headings • 455  
overview • 453  
    overview • 444  
    Reconciliation reports • 446  
    using CA Earl • 444  
Break option • 225, 238, 257, 262, 268, 272  
Browsing BUDTAB table • 257  
Browsing CCCMOD table • 232  
Browsing CCCTAB table • 232  
Browsing DBCRTAB table • 268  
Bud/DBCR option • 225, 238  
Budget browse criteria  
    examples • 286, 287  
browsing by qualifier • 287  
specifying ORD type & period • 286  
    panel (CBDBGTB) • 283  
Budget entry panel (CBDBGTE) • 292  
Budget expanded list panel (CBDBGTX) • 289  
Budget list  
    examples • 290, 291  
    panel (CBDBGTL) • 288  
Budget panels  
    browse criteria (CBDBGTB) • 283

    entry (CBDBGTE) • 292  
    expanded list (CBDBGTX) • 289  
    list (CBDBGTL) • 288  
    primary (CBDBGTP) • 281  
    results (CBQGBTB) • 262  
    results (CBQBGTD) • 262  
Budget query detail report (NN) • 262  
Budget query entry field options  
    selecting fields • 266  
    selecting tables • 266  
    specifying selection criteria • 266  
Budget query summary report • 262  
Budget table (BUDTAB)  
    detail • 475  
    overview • 60  
Budgets, examples  
    Budget list • 290, 291  
    defining a budget • 296, 297  
    deleting a record • 301  
    updating a record • 298  
BUDTAB (Budget table)  
    detail • 475  
    overview • 60

## C

CA ACF2 • 470  
CA Earl  
    batch reporting • 444, 446, 453, 464  
CAJREARL members • 446, 453, 464  
General Ledger interface file • 464  
invoices • 453  
Reconciliation reports • 446  
report control statements • 444  
    CAJREARL members • 448, 455, 465  
CAKRECN1 • 448  
CAKRLIC • 465  
CAKRINV1 • 455  
    program • 444  
CA Top Secret • 469  
CA\$KRLD exit • 422  
CAIKRINP DD statement • 442  
CAIKRPAR parameter file  
    detail • 394  
    overview • 28  
CAIKSPAR parameter file  
    detail • 391  
    overview • 26  
CAJREARL library

---

General Ledger CAKRGLIC • 464  
     invoice members • 453  
 CAKRINV1 • 453  
 CAKRINV2 • 453  
 CAKRINV3 • 453  
     Reconciliation report members • 446  
 CAKRECN1 • 446  
 CAKRECN2 • 446  
 CAJREARL member • 455  
 CAKRARCH  
     member • 399  
     output • 402  
     SAMPJCL • 400  
 CAKRBREC summary processing program • 435  
 CAKRCOMT option  
     control statement • 407  
     output • 411  
     SAMPJCL • 410  
 CAKRCPY option  
     control statement • 412  
     copy table procedure • 412  
     output • 415  
     SAMPJCL • 414  
 CAKRECN1 detail reconciliation report • 450  
 CAKRECN2 detail reconciliation report • 452  
 CAKRECON  
     JCL • 447  
     member for executing CAKSEARL • 446  
 CAKREST option  
     member • 403  
     output • 405  
     SAMPJCL • 404  
 CAKRFCB batch forecasting program • 427  
 CAKRFCST  
     forecast JCL • 433  
     SAMPJCL • 433  
 CAKRGLIC member • 464  
 CAKRINST program • 466  
 CAKRINV1, invoice example 1 • 458  
 CAKRINV2, invoice example 2 • 460  
 CAKRINV3, invoice example 3 • 462  
 CAKRINVC member for executing invoices • 453  
 CAKRLOAD job stream  
     JCL • 420  
     overview • 416  
     processing recommendations • 418  
     processing requirements • 418  
     processing summary report • 425  
 CAKRLOAD user exit • 416, 422  
 CAKRPLS, period close program  
     control parameters • 438  
     JCL • 440  
     overview • 438  
     setup checklist • 439  
 CAKRPOPN, period open program  
     control parameters • 442  
     JCL • 443  
     overview • 441  
 CAKRSUM job stream  
     control parameters • 435  
     JCL • 436  
     overview • 435  
     reports • 436  
 CAKSARCH archive/restore program  
     BACKUP option • 399  
     COMMIT option • 406  
     COPY option • 412  
     RESTORE option • 403  
 CAKSEARL  
     batch reporting • 444  
     PROC • 444  
     procedure • 444  
 Calculation logic • 95  
 CBAPER, Accounting period definition entry panel • 89  
 CBASRCE, Accounting sources entry panel • 78  
 CBASRCI, Accounting sources lookup insert panel • 83  
 CBASRCL, Accounting sources list panel • 75  
 CBASRCP, Accounting sources primary panel • 73  
 CBASRCU, Accounting sources lookup panel • 83  
 CBASRCX, Accounting sources expanded list panel • 77  
 CBASTRE, Accounting structure panel • 69  
 CBCCHPE, Shift chop entry panel • 197  
 CBCELME, Charge elements entry panel • 102  
 CBCELMI, Qualifier insert window, overview • 123  
 CBCELML, Charge elements list panel • 100  
 CBCELMN, Normalizer entry panel • 134  
 CBCELMO, Expanded normalizer entry panel • 137  
 CBCELMP, Charge elements primary panel • 98  
 CBCELMQ, Qualifier entry panel • 123  
 CBCELMR, Qualified rates entry panel • 116  
 CBCELMS, Expanded qualified rates entry panel • 119  
 CBCELMT, Qualifier expanded entry panel • 126  
 CBCELMU, Charge units entry panel • 109  
 CBCELMV, Expanded charge units entry panel • 112

---

---

CBCELMX, Charge elements expanded list panel • 101  
 CBCELNI, Normalizer insert panel via charge elements • 134  
 CBCMODE, Modifier entry panel • 174  
 CBCMODL, Modifier list panel • 172  
 CBCMODP, Modifiers primary panel • 170  
 CBCMODX, Modifier expanded list panel • 173  
 CBCNRME, Normalizer entry panel • 157  
 CBCNRMI, Normalizer insert panel • 157  
 CBCNRML, Normalizer list panel • 155  
 CBCNRMP, Normalizers primary panel • 153  
 CBCNRMV, Expanded normalizer entry panel • 160  
 CBCNRMX, Normalizer expanded list panel • 156  
 CBCOVHE, Overhead distribution entry panel • 218  
 CBCOVHL, Overhead distribution list panel • 215  
 CBCOVHP, Overhead Distribution primary panel • 213  
 CBCOVHX, Overhead distribution expanded list panel • 217  
 CBCQALE, Qualifier entry panel • 165  
 CBCQALI, Qualifier insert panel • 165  
 CBCQALL, Qualifier list panel • 163  
 CBCQALP, Qualifiers primary panel • 161  
 CBCQALV, Qualifier expanded entry panel • 168  
 CBCQALX, Qualifier expanded list panel • 164  
 CBCQLRI, Qualified rate insert panel • 116  
 CBCRECE, Cost recovery entry panel • 208  
 CBCRECL, Cost recovery list panel • 206  
 CBCRECP, Cost recovery primary panel • 204  
 CBCRECX, Cost recovery primary panel • 207  
 CBCSPLE, Split charges entry panel • 191  
 CBCSPLL, Split charges list panel • 189  
 CBCSPLP, Split charges primary panel • 187  
 CBCSPLX, Split charges expanded list panel • 190  
 CBCUNIE, Charge units entry panel • 148  
 CBCUNII, Unit insert panel • 109, 148  
 CBCUNIL, Charge units list panel • 146  
 CBCUNIP, Charge units primary panel • 144  
 CBCUNIV, Expanded charge units entry panel • 112, 151  
 CBCUNIX, Charge unit expanded list panel • 147  
 CBDBGTB, Budget browse criteria panel • 283  
 CBDBGTE, Budget entry panel • 292  
 CBDBGTL, Budget list panel • 288  
 CBDBGTP, Budget primary panel • 281  
 CBDBGTX, Budget expanded list panel • 289  
 CBDCRDB, DB/CR browse criteria • 307  
 CBDCRDE, Debits/Credits entry panel • 316  
 CBDCRDL, Debits/Credits list panel • 311  
 CBDCRDP, Debits/Credits primary panel • 305  
 CBDCRDY, Debits/Credits expanded list panel • 313  
 Cbdefs  
     overview • 18  
 CBOCOPE, copy mod -> tab • 364  
 CBOFCTD, Forecast element panel • 347  
 CBOFCTE, Forecast elements list panel • 344  
 CBOFCTG, Forecast qualifier panel • 352  
 CBOFCTO, Forecast overall results panel • 338  
 CBOFCTP, Forecast primary panel • 336  
 CBOFCTQ, Forecast qualifiers list panel • 349  
 CBOFCTS, Period specifications panel • 336  
 CBOPTNS, User options panel • 369  
 CBOPTVE, Versions panel • 372  
 CBORTEE, Rate Determination elements entry • 356  
 CBORTEQ, Rate Determination qualifiers entry • 359  
 CBQGBTB, Budget query results panel • 262  
 CBQGBTD, Budget query results panel • 262  
 CBQGBTS, Budget query specifications panel • 257  
 CBQCRDB, DB/CR query results panel • 272  
 CBQCRDD, DB/CR query results panel • 272  
 CBQCRDS, DB/CR query specifications panel • 268  
 CBQQRYB, Charge query results panel • 238  
 CBQQRYD, Charge query results panel • 238  
 CBQQRYL, Charge query list panel • 229  
 CBQQRYP, Charge query primary panel • 227  
 CBQQRYS, Charge query specifications panel • 232  
 CBQQRYX, Charge query expanded list panel • 231  
 CBQQRYZ, Charge query results panel • 238  
 CCCMOD (Scratchpad table)  
     detail • 475  
     overview • 60  
 CCCTAB (Consolidated calculated charges table)  
     detail • 476  
     overview • 60  
 CCCTAF synonym • 472  
 Charge algorithm definition table (RATETAB)  
     detail • 483  
     overview • 58  
 Charge element definition table (ELEMENTAB)  
     detail • 478  
     overview • 58  
 Charge elements  
     defining • 106, 107, 114, 115, 121, 122, 128, 130, 139, 140, 141, 182, 183, 184, 185  
     a complex unit with a constant • 115  
     a complex unit without a constant • 114  
     conditional rates • 121, 122

---

---

- flat rate • 140
- modifiers • 182, 183, 184, 185
- normalized complex unit with conditional rate • 107
- normalizers • 139
- preexisting charges • 141
- qualifiers • 128, 130
- simple charge format • 106
- surcharge • 140
  - qualifying normalizers • 133
- Charge elements panels
  - entry (CBCELME) • 102
  - expanded list (CBCELMX) • 101
  - list (CBCELML) • 100
  - primary (CBCELMP) • 98
- Charge modifier table (MODTAB)
  - detail • 479
  - overview • 59
- Charge precision • 102
- Charge query
  - detail report (NN) • 238
  - panels • 227, 229, 231, 232, 238
- expanded list (CBQQRX) • 231
- list (CBQQRYL) • 229
- primary (CBQQRYP) • 227
- results (CBQQRYP) • 238
- results (CBQQRYP) • 238
- results (CBQQRYP) • 238
- specifications (CBQQRYS) • 232
  - summary report (YN) • 238
  - summary with breaks report (YY) • 238
- Charge query,
  - entry field options • 248, 250, 255
- selecting fields • 248
- selecting tables • 250
- specifying order • 255
- specifying selection criteria • 250
- Charge unit definition table (UNITTAB)
  - detail • 485
  - overview • 58
- Charge unit insert panel (CBCUNII) • 148
- Charge units
  - defining a modifier • 182, 183, 184, 185
  - defining a normalizer • 139
  - defining a qualifier • 128, 130
  - defining directly • 142
  - entry panel (CBCELMU) via charge elements • 109
  - insert window (CBCUNII) via charge elements • 109
  - normalizers • 133
  - defining • 133
  - qualifying • 133
    - panels • 109, 144, 146, 147, 148
  - entry panel (UNIE) • 148
  - entry via charge elements • 109
  - expanded list (CBCUNIX) • 147
  - insert panel (CBCUNII) • 148
  - insert window (CBCUNII) via charge elements • 109
  - list panel (CBCUNIL) • 146
  - primary (CBCUNIP) • 144
  - Charge units entry panel (UNIE) • 148
  - Charge units expanded list panel (CBCUNIX) • 147
  - Charge units list panel (CBCUNIL) • 146
  - Charge units panels
    - entry panel (UNIE) • 148
    - expanded list (CBCUNIX) • 147
    - insert panel (CBCUNII) • 148
    - list (CBCUNIL) • 146
    - primary (CBCUNIP) • 144
  - Chargeback algorithms, examples
    - defining a complex unit with a constant • 115
    - defining a complex unit without a constant • 114
    - defining conditional rates • 121, 122
    - defining flat rates • 140
    - defining modifiers • 182, 183, 184, 185
    - defining normalizers • 139
    - defining qualifiers • 128, 130
    - defining qualifiers for normalizers • 133
    - normalized complex unit with conditional rate • 107
    - simple charge format • 106
- Chargeback tables
  - ACCSRTAB (Accounting sources) • 58, 473
  - detail • 473
  - overview • 58
  - ACCSRTAB (Accounting structure) • 58, 474
  - detail • 474
  - overview • 58
  - ACCTLOOK (Lookup) • 58, 474
  - detail • 474
  - overview • 58
  - BUDTAB (Budget) • 60, 475
  - detail • 475
  - overview • 60
  - CCCMOD (Scratchpad) • 60, 475
  - detail • 475
  - overview • 60

---

- 
- CCCTAB (Consolidated calculated charges) • 60, 476
    - detail • 476
    - overview • 60
  - CHOPTAB (Shift chopper definition) • 59, 477
    - detail • 477
    - overview • 59
  - Consolidated calculated charges table (CCCTAB) • 60, 476
    - detail • 476
    - overview • 60
  - DBCRTAB (Debit and credit) • 60, 477
    - detail • 477
    - overview • 60
  - ELEMTAB (Charge element definition) • 58, 478
    - detail • 478
    - overview • 58
  - MODTAB (Charge modifier) • 59, 479
    - detail • 479
    - overview • 59
  - NORMTAB (Unit normalization) • 58, 479
    - detail • 479
    - overview • 58
  - OPTTAB (Option settings definition table) • 480
    - detail • 480
  - OPTTAB (Option settings definition) • 59
    - overview • 59
  - PERTAB (Period definition) • 58, 480
    - detail • 480
    - overview • 58
  - QUALTAB (Algorithm qualifier definition) • 58, 481
    - detail • 481
    - overview • 58
  - QUERYTAB (Saved query definition) • 59, 482
    - detail • 482
    - overview • 59
  - RATETAB (Charge algorithm definition) • 58, 483
    - detail • 483
    - overview • 58
  - SPLITTAB (Split resource definition) • 59, 484
    - detail • 484
    - overview • 59
  - SUMTAB (Summary function definition) • 59, 484
    - detail • 484
    - overview • 59
  - UNITTAB (Charge unit definition) • 58, 485
    - detail • 485
    - overview • 58
  - Choices for prompts, displaying • 40
  - CHOPTAB (Shift chopper definition table)
    - detail • 477
    - overview • 59
  - Color terminal display
    - action bar and pull-down • 485
    - error emphasis • 485
    - function key area • 485
    - messages • 485
    - panel body • 485
    - selection emphasis • 485
  - Command function key (F9) • 31, 55
  - COMMIT control statement • 407
  - Commit processing
    - detail • 406
    - overview • 65
  - Committing tables, CAKRCOMT • 407
  - concepts • 24
  - Conditional rates, defining • 121, 122
  - Consolidated calculated charges table (CCCTAB)
    - detail • 476
    - overview • 60
  - construct version
    - creating constructs • 373
    - viewing committed versions • 374
  - Construct, defining • 67
  - Control parameters
    - CAKRINP DD statement • 442
    - CAKRPLS job stream • 438
    - CAKRPOPN job stream • 442
  - Control statements
    - BACKUP • 399
    - CA Earl batch reporting • 444
    - CAKRCPY • 412
    - CAKRFCST (forecasting) • 428
    - COMMIT • 407
    - RESTORE • 403
  - Conventions
    - entering data • 97
    - entering qualifiers • 30, 97
    - entry fields • 29
    - naming (reserved characters) • 29
    - numeric fields • 30
    - protected fields • 29
    - specifying search strings • 29, 185
  - Copy mod -> tab panel (CBOCOPE) • 364
  - Copy table procedure, CAKRCPY • 412
  - Cost recovery
    - algorithm • 203
-

---

- overview • 203
- Cost recovery panels
  - entry (CBCRECE) • 208
  - expanded list (CBCRECX) • 207
  - list (CBCRECL) • 206
  - primary (CBCRECP) • 204
- D**
- daily processing
  - CAKRLOAD job stream • 416
  - JCL • 420
  - processing recommendations • 418
  - processing requirements • 418
- Data entry conventions • 97
- Data functions
  - Budget • 283, 289, 292
- browse criteria panel (CBDBGTB) • 283
- entry panel (CBDBGTE) • 292
- expanded list panel (CBDBGTX) • 289
  - Budget panels • 281, 283, 289, 292
- browse criteria (CBDBGTB) • 283
- entry (CBDBGTE) • 292
- expanded list (CBDBGTX) • 289
- primary (CBDBGTP) • 281
  - Debits/Credits panels • 305, 307, 311, 313, 316
- DB/CR browse criteria (CBDCRDB) • 307
- entry (CBDCRDE) • 316
- expanded list (CBDCRDX) • 313
- list (CBDCRDL) • 311
- primary (CBDCRDP) • 305
  - Examples • 286, 287, 290, 291, 296, 297, 298, 301, 309, 310, 314, 315, 321, 323, 325, 328, 331
- Budget list, selecting an entry • 290
- Budgets list, selecting an item • 291
- Budgets, browsing by qualifier • 287
- Budgets, defining a budget • 296, 297
- Budgets, deleting a record • 301
- Budgets, specifying ORD type & period • 286
- Budgets, updating a record • 298
- Debits Credits, updating a credit • 325
- Debits/Credits list, selecting an entry • 314
- Debits/Credits list, selecting an item • 315
- Debits/credits, browsing by qualifier • 310
- Debits/Credits, changing a debit to a credit • 328
- Debits/Credits, creating a credit • 321
- Debits/Credits, creating a debit • 323
- Debits/Credits, deleting an entry • 331

- Debits/Credits, specifying by ORD type & period • 309
  - Panels • 281, 283, 288, 289, 292, 305, 307, 311, 313, 316
- CBDBGTB, Budget browse criteria • 283
- CBDBGTE, Budget entry • 292
- CBDBGTL, Budget list • 288
- CBDBGTP, Budgets primary • 281
- CBDBGTX, Budget expanded list • 289
- CBDCRDB, DB/CR browse criteria • 307
- CBDCRDE, Debits/Credits entry • 316
- CBDCRDL, Debits/Credits list • 311
- CBDCRDP, Debits/Credits primary • 305
- CBDCRDX, Debits/Credits expanded list • 313
- DB/CR browse criteria (CBDCRDB) • 307
- Debits/Credits primary (CBDCRDP) • 305
- Data not saved window • 41
- Data tables, overview • 60
- Database related keywords • 392
- DB/CR browse criteria
  - examples • 309, 310
- browsing by qualifier • 310
- specifying ORD type & period • 309
  - panel (CBDCRDB) • 307
- DB/CR query
  - detail report (NN) • 272
  - entry field options • 276
- selecting fields • 276
- selecting tables • 276
- specifying selection criteria • 276
  - panels • 272
- results (CBQCRDB) • 272
- results (CBQCRDD) • 272
  - summary report (YN) • 272
  - summary with breaks report (YY) • 272
- DBCRTAB (Debit and credit table)
  - detail • 477
  - overview • 60
- Debit and credit table (DBCRTAB)
  - detail • 477
  - overview • 60
- Debits/Credits
  - examples • 314, 315, 321, 323, 325, 328, 331
- changing a debit to a credit • 328
- creating a credit • 321
- creating a debit • 323
- Debits/Credits list, selecting an entry • 314
- Debits/Credits list, selecting an item • 315
- deleting an entry • 331

---

updating a credit • 325  
updating a debit • 328  
    panels • 305, 311, 313, 316  
entry (CBDCRDE) • 316  
expanded list (CBDCRDY) • 313  
list (CBDCRDL) • 311  
primary (CBDCRDP) • 305  
Defining  
    a complex unit with a constant • 115  
    a complex unit without a constant • 114  
    accounting sources • 81, 82, 86, 87  
    accounting structures • 67  
    adjustments, overview • 201  
    charge elements • 93, 106, 107, 114, 115, 121, 122  
a complex unit with a constant • 115  
a complex unit without a constant • 114  
conditional rates • 121, 122  
flowchart • 93  
normalized complex unit with conditional rate • 107  
simple charge format • 106  
    charge units, normalizers and qualifiers directly • 142  
    charges, overview • 91  
    conditional rates • 121, 122  
    flat rates • 140  
    modifiers • 182, 183, 184, 185  
    normalized complex unit with conditional rate • 107  
    normalizers • 133, 139  
    preexisting charges • 141  
    qualifiers • 128, 130, 133  
    shift chop • 199  
    split resources • 186  
Definition tables, overview • 58, 59  
Development version • 24  
Display fields, identifying • 29  
Displaying  
    choices for prompts • 40  
    genlevel • 379  
    product genlevel • 39, 379  
    prompts • 40

## E

ELEMTAB (Charge element definition table)  
    detail • 478  
    overview • 58  
Entry fields, display conventions • 29

Entry insert panel • 52  
Entry panel function key settings • 49  
Entry panel insert pop-up windows • 41  
Examples  
    Accounting sources • 81, 82, 86, 87  
    creating a lookup table • 86, 87  
    defining a structure without a Lookup Table • 81  
    defining sources for a structure with Lookup Table • 82  
        Batch processing • 396, 399, 403, 408  
BACKUP control statement • 399  
CAKREST control statement • 403  
Committing a Development version • 408  
daily processing • 396  
    Budget Query, specifying selection criteria within the ORD type field • 267  
    Budgets • 286, 287, 290, 291, 296, 297, 298, 301  
    browsing by qualifier • 287  
    budget list • 290, 291  
    defining a budget • 296, 297  
    deleting a record • 301  
    specifying by ORD type & period • 286  
    updating a record • 298  
        Charge elements • 106, 107, 114, 115, 121, 122, 128, 130, 131, 132, 133, 139, 140, 141, 182, 183, 184, 185  
\*ONE\* usage • 140  
bringing in preexisting charges • 141  
charging a flat rate • 140  
conditional rates, defining • 122  
defining a complex unit with a constant • 115  
defining a complex unit without a constant • 114  
defining conditional rates • 121  
modifiers, defining • 182, 183, 184, 185  
normalized complex unit with conditional rate • 107  
normalizers, defining • 139  
normalizers, defining qualifiers • 133  
preexisting charges, bringing in • 141  
qualifiers, defining • 128, 130, 131, 132, 133  
simple charge format • 106  
    Charge Query • 249, 251, 252, 254, 256  
entering multiple selection criteria • 254  
entering selection criteria within the Charge element field • 251  
entering selection criteria within the Period number field • 252  
grouping CCCTAB or CCCMOD fields • 249  
using the Srt option • 256  
    committing a Development version • 407

---

- Cost recovery • 210, 211
- Creating a lookup table • 86, 87
- DB/CR Query, specifying selection criteria within the charge element field • 277
- Debits/Credits • 309, 310, 314, 315, 321, 323, 325, 328, 331
- browsing by qualifier • 310
- changing a debit to a credit • 328
- creating a credit • 321
- creating a debit • 323
- Debits/Credits list, selecting an entry • 314
- Debits/Credits list, selecting an item • 315
- deleting an entry • 331
- specifying by ORD type & period • 309
- updating a credit • 325
  - Forecast • 341, 342, 354
- adjusting qualifier amounts • 354
- forecasting using the line algorithm • 341
- forecasting using the smooth algorithm • 342
  - Lookup table • 82, 86, 87
- creating entities • 86, 87
- defining sources for a structure with Lookup Table • 82
  - Modifiers, defining • 182, 183, 184, 185
  - Normalizers • 133
- defining • 133
- qualifying • 133
  - Overhead distribution • 221, 222
  - Period, performing a manual adjustment • 340
  - Qualifiers, defining • 128, 130, 131, 132
  - Rate determination, recovering charges • 362
  - Split charge • 194, 195
  - Versions via Versions panel • 373, 374, 375
- Exit
  - function key (F3) • 31
  - pull-down • 37
  - user • 416, 422
- Exiting Help • 382
- Expanded
  - charge units entry panel • 112, 151
  - normalizer entry panel • 137, 160
  - qualified rates entry panel • 119
- Extended charging • 96

## F

- F1=Help function key • 31, 55
- F10=Action Bar function key • 55
- F3=Exit function key • 31, 55

- F4=Prompt function key • 31, 55
- F9=Command function key • 31, 55
- Features, overview • 14
- Field Help • 384
- Fields, identifying protected areas • 29
- Flat rate, charging • 140
- Flowcharts
  - CA PMA Chargeback record processing • 416
  - Defining charge elements • 93
- Forecast
  - control statement • 431
  - methods • 431
  - panels • 336, 338, 344, 347, 349, 352
- element (CBOFCTD) • 347
- elements list (CBOFCTE) • 344
- overall results (CBOFCTO) • 338
- primary (CBOFCTP) • 336
- qualifier (CBOFCTG) • 352
- qualifiers list (CBOFCTQ) • 349
- Forecasting control report • 434
- Forecasting, batch
  - CAKRFCSB program • 427
  - CAKRFCSB • 428
  - control report • 434
  - reporting • 434
- Function key availability when windowing • 39
- Function key settings
  - entry panels • 49
  - for Help • 381
  - global • 55
  - global settings • 31
  - list panels • 46
  - Local settings • 55
  - primary panel • 43
- Function keys, summary • 54, 55

## G

- General Ledger interface file • 464
- Genlevel, displaying • 31, 39, 379
- Global function key settings • 31, 55
- Glossary • 485

## H

- Headings, invoices • 455
- Help
  - function key (F1) • 31
  - panels, overview • 42
  - pull-down • 38

---

## Help facility

- displaying genlevel • 379
- exiting Help • 382
- field help • 384
- for action bar choices • 377
- function key settings • 381
- help for help • 388
- Index • 387
- overview • 377
- panel help • 383
- table of contents panel • 385
- topic • 386

## Help for Help panel • 388

## How information is displayed

- entry fields • 29
- genlevel • 379
- numerics • 30
- protected fields • 29

## How windows work • 39

## I

### Identifying

- input fields • 29
- protected fields • 29

### Index Help panel • 387

### Input fields, identifying • 29

### Insert pop-up windows

- Accounting sources lookup insert, CBASRCI • 83
- Normalizer (CBCELNI) via charge elements • 134
- Normalizer (CBCNRMII) • 157
- Qualified rate insert, CBCQLRI • 116
- Qualifier (CBCQALI) • 123, 165
- Unit insert, CBCUNII • 109
- Units (CBCUNII) • 148

### Internal tables • 61

### Interrelationship between CA PMA Chargeback

#### versions

- COMMIT • 65
- overview • 63

### invoice processing • 453

### invoice reports

- example 1 (CAKRINV1) • 458
- example 2 (CAKRINV2) • 460
- example 3 (CAKRINV3) • 462
- headings • 455
- overview • 453

## J

### JCL

- CA\$KRLD exit • 422
- CAJREARL members • 448, 455, 465
- CAKRECN1 • 448
- CAKRGLIC • 465
- CAKRINV1 • 455
  - CAKARES PROC • 389
  - CAKRARCH member • 399, 400
  - CAKRCOMT member • 410
  - CAKRCPY member • 414
  - CAKRECON member • 446, 447
  - CAKREST member • 403, 404
  - CAKRFCST member • 433
  - CAKRGLIC MACLIB member • 464
  - CAKRINV1, invoice example 1 • 458
  - CAKRINV2, invoice example 2 • 460
  - CAKRINV3, invoice example 3 • 462
  - CAKRINVC MACLIB member • 454
  - CAKRLOAD member • 416
  - CAKRPLCS • 438, 440

### job stream • 440

### member • 438

- CAKRPOPN • 441, 443

### job stream • 443

### member • 441

- CAKRSUM member • 436
- CAKSARES PROC • 398
- CAKSEARL PROC • 445, 446, 453

### invoice, CAJREARL members • 453

### Reconciliation report, CAJREARL members • 446

- Period close, CAKRPLCS job stream • 440
- PROCs • 398, 445, 446, 453, 465

### CAKSARES • 398

### CAKSEAR2 • 465

### CAKSEARL • 445, 446, 453

- summary processing, CAKRSUM job stream • 436

## K

### Keywords

- CA PMA Chargeback related • 393
- CAIKRPAR used by all CA PMA Chargeback batch processes • 394
- CAIWFPAR used by CAKRLOAD • 395
- database related • 392
- DataManager related • 393
- reporting related • 393

---

## L

- List panel function key settings • 46
- Lookup table (ACCTLOOK)
  - creating • 83
  - detail • 474
  - examples • 82, 86, 87
  - overview • 58

## M

- Managing CA PMA Chargeback tables
  - archiving • 399
  - COMMIT processing • 406
  - commit processing overview • 65
  - restoring • 403
- Masterpiece, CA GENERAL LEDGER • 464
- Maximum charge • 102
- Memory requirements, daily processing • 418
- Minimum charge • 102
- Modifier definition • 169
- Modifier panels
  - entry (CBCMODE) • 174
  - expanded list (CBCMODX) • 173
  - list (CBCMODL) • 172
  - primary (CBCMODP) • 170
- Modifiers
  - defining • 182, 183, 184, 185
  - examples • 182, 183, 184, 185
  - expanded list panel (CBCMODX) • 173
- MODTAB (Charge modifier table)
  - detail • 479
  - overview • 59
- Monochrome terminal display
  - action bar and pull-down • 485
  - error emphasis • 485
  - function key area • 485
  - messages • 485
  - panel body • 485
  - selection emphasis • 485
- Move option, for CA PMA Chargeback panels • 36

## N

- Naming conventions, reserved characters • 29
- Normalization of charge units • 107, 114
- Normalizer
  - panels • 134, 153, 155, 156, 157
- entry (CBCNRME) • 157
- entry via charge elements (CBCELMN) • 134

- expanded list (CBCNRMX) • 156
- factor decimal precision • 134, 157
- insert (CBCELNI) via charge elements • 134
- insert panel (CBCNRMI) • 157
- list (CBCNRML) • 155
- primary (CBCNRMP) • 153
- Normalizers
  - defining • 133, 142
  - examples • 138, 139
  - qualifying • 133
- NORMTAB (Unit normalization table)
  - detail • 479
  - overview • 58
- Numeric precision • 30

## O

- Online functions • 18
- OPTION settings definition table (OPTTAB)
  - detail • 480
  - overview • 59
- Options
  - panels • 369, 372
- User options, CBOPTNS • 369
- Versions, CBOPTVE • 372
  - pull-down • 367
  - setting • 367
- OPTTAB (Option settings definition table)
  - detail • 480
  - overview • 59
- ORD type
  - ALL • 29, 30
- Overhead allocation & cost recovery (CAKRSUM)
  - report • 436
- Overhead distribution
  - algorithm • 212
  - examples • 221, 222
  - panels • 213, 215, 217, 218, 221
- Overhead distribution panels
  - entry (CBCOVHE) • 218
  - expanded list (CBCOVHX) • 217
  - list (CBCOVHL) • 215
  - primary (CBCOVHP) • 213

## P

- PA1=Susp function key • 31, 55
- Panel action • 36
- Panel displays
  - color terminals • 485

---

action bar and pull-down • 485  
 error emphasis • 485  
 function key area • 485  
 messages • 485  
 panel body • 485  
 selection emphasis • 485  
     monochrome terminals • 485  
 action bar and pull-down • 485  
 error emphasis • 485  
 function key area • 485  
 messages • 485  
 panel body • 485  
 selection emphasis • 485  
 Panel pull-down • 36  
 Panels  
     Accounting periods entry (CBAPER) • 89  
     Accounting sources • 73, 75, 77, 78, 83  
 entry (CBASRCE) • 78  
 expanded list (CBASRCX) • 77  
 list (CBASRCL) • 75  
 lookup (CBASRCU) • 83  
 primary (CBASRCP) • 73  
     Accounting sources lookup • 83  
 insert pop-up window • 83  
     Accounting structure (CBASTRE) • 69  
     Budget • 281, 283, 288, 289, 292  
 browse criteria (CBDBGTB) • 283  
 entry (CBDBGTE) • 292  
 expanded list (CBDBGTX) • 289  
 list (CBDBGTL) • 288  
 query specifications (CBDBGTP) • 281  
     Budget query • 257, 262  
 results (CBQBGTB) • 262  
 results (CBQBGTD) • 262  
 Specifications (CBQBGTS) • 257  
     CBAPER, Accounting periods entry • 89  
     CBASRCE, Accounting sources • 78  
 entry • 78  
     CBASRCI, Accounting sources lookup insert • 83  
     CBASRCL, Accounting sources list • 75  
     CBASRCP, Accounting sources primary • 73  
     CBASRCU, Accounting sources lookup • 83  
     CBASRCX, Accounting sources expanded list • 77  
     CBASTRE, Accounting structure • 69  
     CBCCHPE, Shift chop entry • 197  
     CBCELME, Charge elements entry • 102  
     CBCELML, Charge elements list • 100  
     CBCELMN, Normalizer entry • 134  
     CBCELMO, Expanded normalizer entry • 137  
     CBCELMP, Charge elements primary • 98  
     CBCELMQ, Qualifier entry • 123  
     CBCELMR, Qualified rates entry • 116  
     CBCELMS, Expanded qualified rates entry • 119  
     CBCELMT, Qualifier expanded entry via Charge  
         elements • 126  
     CBCELMU, Charge units entry • 109  
     CBCELMV, Expanded charge units entry • 112  
     CBCELMX, Charge elements expanded list • 101  
     CBCELNI Normalizer insert via charge elements •  
         134  
     CBCMODE, Modifier entry • 174  
     CBCMODL, Modifier list • 172  
     CBCMODP, Modifiers primary • 170  
     CBCMODX, Modifier expanded list • 173  
     CBCNRME, Normalizer entry • 157  
     CBCNRMI, Normalizer insert • 157  
     CBCNRML, Normalizer list • 155  
     CBCNRMP, Normalizers primary • 153  
     CBCNRMV, Expanded normalizer entry • 160  
     CBCNRMX, Normalizer expanded list • 156  
     CBCOVHE, Overhead distribution entry • 218  
     CBCOVHL, Overhead distribution list • 215  
     CBCOVHP, Overhead distribution primary • 213  
     CBCOVHX, Overhead distribution expanded list •  
         217  
     CBCQALE, Qualifier entry • 165  
     CBCQALI, Qualifier insert • 165  
     CBCQALL, Qualifier list • 147, 163, 164  
     CBCQALP, Qualifiers primary • 161  
     CBCQALV, Qualifier expanded entry • 168  
     CBCQLRI, Qualified rate insert • 116  
     CBCRECE, Cost recovery entry • 208  
     CBCRECL, Cost recovery list • 206  
     CBCRECP, Cost recovery primary • 204  
     CBCRECX, Cost recovery expanded list • 207  
     CBCSPLE, Split charges entry • 191  
     CBCSPLL, Split charges list • 189  
     CBCSPLP, Split charges primary • 187  
     CBCSPLX Split charges expanded list • 190  
     CBCUNIE, Charge units entry • 148  
     CBCUNII, Units insert • 148  
     CBCUNIL, Charge units list • 146  
     CBCUNIP, Charge units primary • 144  
     CBCUNIV, Expanded charge units entry • 112,  
         151  
     CBDBGTB, Budget browse criteria • 283  
     CBDBGTE, Budget entry • 292  
     CBDBGTL, Budget list • 288

---

---

CBDBGTP, Budgets primary • 281  
 CBDBGTX, Budget expanded list • 289  
 CBDCRDB, DB/CR browse criteria • 307  
 CBDCRDE, Debits/Credits entry • 316  
 CBDCRDL, Debits/Credits list • 311  
 CBDCRDP, Debits/Credits primary • 305  
 CBDCRDX, Debits/Credits expanded list • 313  
 CBOCOPE, Copy mod -> tab copy • 364  
 CBOFCTD, Forecast qualifier • 347, 352  
 CBOFCTE, Forecast elements list • 344  
 CBOFCTO, Forecast overall results • 338  
 CBOFCTP, Forecast primary • 336  
 CBOFCTQ, Forecast qualifiers list • 349  
 CBOFCTS, Period specifications • 336  
 CBOPTNS, User options • 369  
 CBOPTVE, Versions • 372  
 CBORTEE, Rate Determination elements entry • 356  
 CBORTEQ, Rate Determination qualifiers entry • 359  
 CBQBGTB, Budget query results • 262  
 CBQBGTD, Budget query results • 262  
 CBQBGTS, Budget query specifications • 257  
 CBQCRDB, DB/CR query results • 272  
 CBQCRDD, DB/CR query results • 272  
 CBQCRDS, DB/CR query specifications • 268  
 CBQCRYB, Charge query results • 238  
 CBQCRYD, Charge query results • 238  
 CBQCRYL, Charge query list • 229  
 CBQCRYP, Charge query primary • 227  
 CBQCRYX, Charge query specifications • 232  
 CBQCRYX, Charge query expanded list • 231  
 CBQCRYZ, Charge query results • 238  
 Charge elements • 98, 100, 101, 102  
 entry (CBCELME) • 102  
 expanded list (CBCELMX) • 101  
 list (CBCEMLM) • 100  
 primary (CBCELMP) • 98  
     Charge query • 227, 229, 231, 232, 238  
 expanded list (CBQCRYX) • 231  
 list (CBQCRYL) • 229  
 primary (CBQCRYP) • 227  
 results (CBQCRYB) • 238  
 results (CBQCRYD) • 238  
 results (CBQCRYZ) • 238  
 specifications (CBQCRYX) • 232  
     Charge units • 109, 144, 146, 147, 148  
 entry • 148  
 entry via charge elements • 109  
 expanded list (CBCUNIX) • 147  
 list (CBCUNIL) • 146  
 primary (CBCUNIP) • 144  
     Copy mod -> tab (CBOCOPE) • 364  
     Cost recovery • 204, 206, 207, 208  
 entry (CBCRECE) • 208  
 expanded list (CBCRECX) • 207  
 list (CBCRECL) • 206  
 primary (CBCRECP) • 204  
     Data entry • 281, 283, 288, 289, 292, 305, 307, 311, 313, 316  
 Budget browse criteria (CBDBGTB) • 283  
 Budget expanded list (CBDBGTX) • 289  
 Budget list (CBDBGTL) • 288  
 Budgets entry (CBDBGTE) • 292  
 Budgets primary (CBDBGTP) • 281  
 DB/CR browse criteria (CBDCRDB) • 307  
 Debits/Credits entry (CBDCRDE) • 316  
 Debits/Credits expanded list (CBDCRDX) • 313  
 Debits/Credits list (CBDCRDL) • 311  
 Debits/Credits primary (CBDCRDP) • 305  
     DB/CR query • 268, 272  
     results (CBQCRDB) • 272  
     results (CBQCRDD) • 272  
     Specifications (CBQCRDS) • 268  
         Debits/Credits • 305, 307, 311, 313, 316  
 DB/CR browse criteria (CBDCRDB) • 307  
 entry (CBDCRDE) • 316  
 expanded list (CBDCRDX) • 313  
 list (CBDCRDL) • 311  
 primary (CBDCRDP) • 305  
     Expanded charge units entry • 112, 151  
     Expanded normalizer entry • 137, 160  
     Expanded qualified rates entry • 119  
     Forecast • 336, 338, 344, 347, 349, 352  
 element (CBOFCTD) • 347  
 elements list (CBOFCTE) • 344  
 overall results (CBOFCTO) • 338  
 primary (CBOFCTP) • 336  
 qualifiers (CBOFCTG) • 352  
 qualifiers list (CBOFCTQ) • 349  
     Help • 42, 383, 384, 385, 386, 387, 388  
 Help for help • 388  
 Help with a field • 384  
 Help with a panel • 383  
 Index • 387  
 overview • 42  
 Table of contents • 385  
 topic panel • 386

---

---

Insert windows • 83, 116, 123, 134, 148, 157, 165  
Accounting sources lookup insert, CBASRCI • 83  
Normalizer (CBCELNI) via charge elements • 134  
Normalizer (CBCNRMI) • 157  
Qualified rate insert, CBCQLRI • 116  
Qualifier (CBCQALI) • 123, 165  
Units (CBCUNII) • 148  
    Modifiers • 170, 172, 173, 174  
entry (CBCMODE) • 174  
expanded list (CBCMODX) • 173  
list (CBCMODL) • 172  
primary (CBCMODP) • 170  
    Normalizer • 134, 153, 155, 156, 157  
entry (CBCNRME) • 157  
entry via charge elements (CBCELMN) • 134  
expanded list (CBCNRMX) • 156  
insert (CBCELNI) via charge elements • 134  
list (CBCNRML) • 155  
primary (CBCNRMP) • 153  
    Normalizer insert (CBCELNI) via charge elements  
    • 134  
    Normalizer insert (CBCNRMI) • 157  
    Options • 369, 372  
User options, (CBOPTNS) • 369  
Versions, (CBOPTVE) • 372  
    Overhead distribution • 213, 215, 217, 218  
entry (CBCOVHE) • 218  
expanded list (CBCOVHX) • 217  
list (CBCOVHL) • 215  
primary (CBCOVHP) • 213  
    Period specifications (CBOFCTS) • 336  
    Qualified rate insert • 116  
    Qualified rates entry (CBCELMR) • 116  
    Qualifiers • 126, 161, 163, 164, 165, 168  
entry (CBCQALE) • 165  
expanded entry (CBCELMT) via Charge elements •  
126  
expanded entry (CBCQALV) • 168  
expanded list (CBCQALX) • 164  
insert (CBCQALI) • 165  
list (CBCQALL) • 163  
primary (CBCQALP) • 161  
    Rate Determination • 356, 359  
elements entry (CBORTEEE) • 356  
qualifiers entry (CBORTEEQ) • 359  
    Sample • 43, 46, 48, 49, 51, 52  
entry • 49  
entry insert • 52  
expanded entry • 51

expanded list • 48  
list • 46  
primary • 43  
    Shift chop entry (CBCCHPE) • 197  
    Split charges • 187, 189, 190, 191  
entry (CBCSPLE) • 191  
expanded list (CBCSPLX) • 190  
list (CBCSPLL) • 189  
primary (CBCSPLP) • 187  
    Unit insert window via charge elements • 109  
    Units insert (CBCUNII) • 148  
    User settings, (CBOPTNS) • 369  
    Versions, (CBOPTVE) • 372  
Parameter files  
    CAIKRPAR • 394  
detail • 394  
    CAIKRPAR overview • 28  
    CAIKSPAR • 26, 391  
detail • 391  
overview • 26  
Period close  
    CAKRPCLS job stream • 438, 439, 440  
control parameters • 438  
JCL • 440  
setup • 439  
    processing summary report • 441  
Period definition table (PERTAB)  
    detail • 480  
    overview • 58  
Period functions  
    examples • 340, 341, 342, 354, 362  
forecast, adjusting qualifier amounts • 354  
forecast, performing a manual adjustment • 340  
forecast, using smooth algorithm • 342  
forecast, using the line algorithm • 341  
rate determination, recovering charges • 362  
    overview • 335  
Period open  
    CAKRPOPJ job stream • 441, 442  
control parameters • 442  
overview • 441  
    CAKRPOPJ program • 441  
    processing summary report • 444  
Period specifications panel (CBOFCTS) • 336  
Permanent disk space • 418  
PERTAB (Period definition table)  
    detail • 89, 480  
    overview • 58  
Precision

---

- Normalizer factor • 134, 157
  - numeric • 30, 102
- Preexisting charges, bringing in • 141
- Printing
  - CA Earl reconciliation file reports • 446
  - CA PMA Chargeback tables • 485
  - invoices • 453
- Processing
  - Options • 225, 238
- Break • 225, 238
- Bud/DBCR • 225, 238
- Summarize • 225, 238
  - period close • 438
  - period open • 441
  - requirements • 418
- CA PMA Chargeback memory • 418
- temporary work area • 418
  - summary • 435
  - summary report (CAKRLOAD) • 425
- Processing Options
  - Break • 257, 262, 268, 272
  - Summarize • 257, 262, 268, 272
- PROCs
  - CAKSARES (archive/restore) • 397, 398
  - CAKSEAR2, CA GENERAL LEDGER interface file • 465
  - CAKSEARL, CA Earl batch reporting • 444, 445
  - summary table • 389
- Product genlevel • 39
- Programs
  - CA Earl • 444
  - CAKRBREC summary processing • 435
  - CAKRFCSB batch forecasting • 427
  - CAKRINST • 466
- overview • 466
  - CAKRPCLS, period close • 438
  - CAKRPOPEN, period open • 441
  - CAKSARCH, archive/restore • 397, 399, 403, 406, 412
- BACKUP option • 399
- COMMIT option • 406
- COPY option • 412
- overview • 397
- RESTORE option • 403
  - SQUL execution (CAKRINST) • 466
  - summary table • 389
- Prompt function key (F4) • 31
- Prompt pop-up window • 40
- Prompts, displaying • 40

- Protected fields, identifying • 29
- Pull-downs
  - Help • 377

## Q

- Qualified rate insert pop-up window, CBCELMQ • 116
- Qualifier entry
  - conventions • 30, 97
  - panels • 116, 123, 165
- (CBCQALE) • 165
- rates (CBCELMR) • 116
- via Charge elements (CBCELMQ) • 123
- Qualifier expanded
  - entry panels • 126, 168
- (CBCELMT) via Charge elements • 126
- (CBCQALV) • 168
  - list panel (CBCQALX) • 164
- Qualifier insert
  - panels (CBCQALI) • 165
  - pop-up window • 123
- Qualifier list panel (CBCQALL) • 163
- Qualifier rate insert panel (CBCQLRI) • 116
- Qualifiers
  - defining • 128, 130, 133
  - defining directly • 142
  - panels • 126
- expanded entry (CBCELMT) via Charge elements • 126
- Qualifiers panels
  - entry (CBCELMQ) via charge elements • 123
  - entry (CBCQALE) • 165
  - expanded entry (CBCQALV) • 168
  - expanded list (CBCQALX) • 164
  - insert window (CBCQALI) • 165
  - list (CBCQALL) • 163
  - primary (CBCQALP) • 161
- QUALTAB (Algorithm qualifier definition table)
  - detail • 481
  - overview • 58
- Query functions
  - Budget query specifications panel (CBQBGTS) • 257
  - Charge query list panel (CBQQRYL) • 229
  - Charge query primary panel (CBQQRYP) • 227
  - Charge query primary panel (CBQQRYS) • 232
  - DB/CR query specifications panel (CBQCRDS) • 268
  - Examples • 249, 251, 252, 254, 256, 267, 277

---

Budget, specifying the selection criteria within the ORD type field • 267  
charge • 249, 251, 252, 254, 256  
DB/CR, specifying the selection criteria within the Charge element field • 277  
    overview • 223  
Query system security • 467, 472  
Query, selecting budget, debit and credit information • 238  
QUERYTAB (Saved query definition table)  
    detail • 482  
    overview • 59

## R

RACF • 471  
Rate Determination panels  
    elements entry (CBORTEE) • 356  
    qualifiers entry (CBORTEQ) • 359  
Rate precision • 102  
RATETAB (Charge algorithm definition table)  
    detail • 483  
    overview • 58  
Reconciliation reports  
    Detail report (CAKRECN1) • 450  
    Detail report (CAKRECN2) • 452  
    overview • 446  
Record processing, description • 416  
Recovery charge algorithm • 203  
Register conventions • 422  
Reporting  
    batch • 434, 446, 450, 452, 453, 455, 458, 460, 462  
Forecasting • 434  
invoices • 455, 458, 460, 462  
    example 1 (CAKRINV1) • 458  
    example 2 (CAKRINV2) • 460  
    example 3 (CAKRINV3) • 462  
    headings • 455  
invoices, overview • 453  
reconciliation • 446, 450  
reconciliation (CAKRECN2) • 452  
    CA Earl • 444, 446, 453  
batch processing overview • 444  
invoices • 453  
Reconciliation reports • 446  
    General Ledger interface file • 464  
Reports  
    CAKRARCH output • 402

CAKRCOMT output • 411  
CAKRCPY output • 415  
CAKREST output • 405  
CAKRLOAD processing summary • 425  
Forecasting, control • 434  
invoice example 1, CAKRINV1 • 455, 458  
invoice example 2, CAKRINV2 • 460  
invoice example 3, CAKRINV3 • 462  
Overhead allocation & cost recovery • 436  
Period close processing summary • 441  
Period open processing summary • 444  
Reconciliation • 446, 450, 452  
Detail report (CAKRECN1) • 450  
Detail report (CAKRECN2) • 452  
overview • 446  
RESTORE option • 403  
Restore procedure, CAKSARES • 389  
Restoring tables • 403  
Rules  
    for archiving/backing up tables • 399  
    for restoring tables • 403  
    how information is displayed • 29  
    naming conventions • 29  
    specifying search strings • 29

## S

SAMPJCL  
    CA\$KRLD exit • 422  
    CAJREARL members • 448, 455, 465  
CAKRECN1 • 448  
CAKRGLIC • 465  
CAKRINV1 • 455  
    CAKRARCH member • 400  
    CAKRCOMT member • 410  
    CAKRCPY member • 414  
    CAKRECON member • 447  
    CAKREST member • 404  
    CAKRFCST member • 428, 433  
    CAKRINV1, invoice example 1 • 458  
    CAKRINV2, invoice example 2 • 460  
    CAKRINV3, invoice example 3 • 462  
    CAKRINVC MACLIB member • 454, 464  
    CAKRLOAD member • 416  
    CAKRPLS member • 438  
    CAKRPOPN member • 441, 443  
    CAKRSUM member • 436  
CAKSARES PROC • 398  
CAKSEAR2 PROC • 464

---

- CAKSEARL PROC • 445, 446, 453
- Invoicing, CAJREARL members • 453
- overview • 445
- Reconciliation file, CAJREARL members • 446
  - membername summary • 389
  - PROCs • 398, 445
- CAKSARES • 398
- CAKSEARL • 445
- Sample product panels
  - entry • 49
  - entry insert • 52
  - expanded entry • 51
  - expanded list • 48
  - list • 46
  - primary • 43
- Sample reports
  - Forecasting control • 434
  - invoices • 455, 458, 460, 462
- CAKRINV1 (example 1) • 458
- CAKRINV2 (example 2) • 460
- CAKRINV3 (example 3) • 462
- headings • 455
  - Reconciliation • 450, 452
- CAKRECN1 • 450
- CAKRECN2 • 452
- Saved query definition table (QUERYTAB)
  - detail • 482
  - overview • 59
- Scratchpad table (CCCMOD)
  - detail • 475
  - overview • 60
- Scroll bar
  - list panel • 46
- Search strings, specifying • 29, 185
- Security
  - CA ACF2 • 470
  - CA PMA Chargeback query system • 472
  - CA Top Secret • 469
  - overview • 469
  - RACF • 471
  - rule • 467
- setting options • 367
- Setup checklists • 439
- Shift chop entry panel (CBCCHPE) • 197
- Shift chop, defining • 199
- Shift chopper definition table (CHOPTAB)
  - detail • 477
  - overview • 59
- Specifying search strings • 29, 185

- Specifying versions via Versions panel
  - examples • 373, 374, 375
  - overview • 372
- Split charge
  - examples • 194, 195
  - splitting a charge among four levels • 195
  - splitting a charge between two levels • 194
    - panels • 187, 189, 190, 191
  - entry (CBCSPLE) • 191
  - expanded list (CBCSPLX) • 190
  - list (CBCSPLL) • 189
  - primary (CBCSPLP) • 187
- Split percentages, overview • 59
- Split resource definition • 186
- Split resource definition table (SPLITTAB)
  - detail • 484
  - overview • 59
- SPLITTAB (Split resource definition table)
  - detail • 484
  - overview • 59
- SQL wildcard character • 29, 185
- Starting CA PMA Chargeback • 31
- Summarize option • 225, 238, 257, 262, 268, 272
- Summary
  - control statement • 431
  - forecast methods • 431
  - function definition table (SUMTAB) • 59, 484
- detail • 484
- overview • 59
- processing (CAKRSUM) • 435, 436
- control parameters • 435
- JCL • 436
- overview • 435
  - processing program (CAKRBREC) • 435

SUMTAB (Summary function definition table)

- detail • 484
- overview • 59

Surcharge, defining • 140

Susp function key (PA1) • 31

Suspending panels • 36, 39

## T

- Table maintenance functions
  - defining adjustments • 201
  - defining charges • 91
- Table of Contents Help panel • 385
- Temporary work area • 418
- Terms, CA PMA Chargeback overview • 21

---

Topic Help panel • 386

## U

Unit insert panels (CBCUNII) • 109

Unit normalization table (NORMTAB)  
detail • 479

overview • 58

Unit precision • 102

Units insert panels (CBCUNII) • 148

UNITTAB (Charge unit definition table)  
detail • 485

overview • 58

user exit for CAKRLOAD • 422

User settings for CA PMA Chargeback • 369

## V

version

development • 24

interrelationships • 64

overview • 63

panel (CBOPTVE) • 372

## W

Wildcard character • 29, 185

Windowing • 39

Windows

About (displays genlevel) • 39, 379

Are you sure? • 371

Data not saved • 41

Entry panel insert pop-up • 41

Panel pull-down • 36

Prompt pop-up • 40