

CA PMA Chargeback™

DataManager User Guide

r12.5



This documentation and any related computer software help programs (hereinafter referred to as the "Documentation") are for your informational purposes only and are subject to change or withdrawal by CA at any time.

This Documentation may not be copied, transferred, reproduced, disclosed, modified or duplicated, in whole or in part, without the prior written consent of CA. This Documentation is confidential and proprietary information of CA and may not be used or disclosed by you except as may be permitted in a separate confidentiality agreement between you and CA.

Notwithstanding the foregoing, if you are a licensed user of the software product(s) addressed in the Documentation, you may print a reasonable number of copies of the Documentation for internal use by you and your employees in connection with that software, provided that all CA copyright notices and legends are affixed to each reproduced copy.

The right to print copies of the Documentation is limited to the period during which the applicable license for such software remains in full force and effect. Should the license terminate for any reason, it is your responsibility to certify in writing to CA that all copies and partial copies of the Documentation have been returned to CA or destroyed.

TO THE EXTENT PERMITTED BY APPLICABLE LAW, CA PROVIDES THIS DOCUMENTATION "AS IS" WITHOUT WARRANTY OF ANY KIND, INCLUDING WITHOUT LIMITATION, ANY IMPLIED WARRANTIES OF MERCHANTABILITY, FITNESS FOR A PARTICULAR PURPOSE, OR NONINFRINGEMENT. IN NO EVENT WILL CA BE LIABLE TO THE END USER OR ANY THIRD PARTY FOR ANY LOSS OR DAMAGE, DIRECT OR INDIRECT, FROM THE USE OF THIS DOCUMENTATION, INCLUDING WITHOUT LIMITATION, LOST PROFITS, LOST INVESTMENT, BUSINESS INTERRUPTION, GOODWILL, OR LOST DATA, EVEN IF CA IS EXPRESSLY ADVISED IN ADVANCE OF THE POSSIBILITY OF SUCH LOSS OR DAMAGE.

The use of any software product referenced in the Documentation is governed by the applicable license agreement and is not modified in any way by the terms of this notice.

The manufacturer of this Documentation is CA.

Provided with "Restricted Rights." Use, duplication or disclosure by the United States Government is subject to the restrictions set forth in FAR Sections 12.212, 52.227-14, and 52.227-19(c)(1) - (2) and DFARS Section 252.227-7014(b)(3), as applicable, or their successors.

Copyright © 2010 CA. All rights reserved. All trademarks, trade names, service marks, and logos referenced herein belong to their respective companies.

Contact CA

Contact Technical Support

For your convenience, CA provides one site where you can access the information you need for your Home Office, Small Business, and Enterprise CA products. At <http://ca.com/support>, you can access the following:

- Online and telephone contact information for technical assistance and customer services
- Information about user communities and forums
- Product and documentation downloads
- CA Support policies and guidelines
- Other helpful resources appropriate for your product

Provide Feedback

If you have comments or questions about CA product documentation, you can send a message to techpubs@ca.com.

If you would like to provide feedback about CA product documentation, complete our short [customer survey](#), which is also available on the CA Support website, found at <http://ca.com/docs>.

Contents

Chapter 1: Introduction	9
Features	9
CA Common Services for z/OS Overview	9
What is ViewPoint?	10
What is the CA EARL Service?	10
What is CA LMP?	11
What is CAIRIM?	11
What is the CA SRAM Service?	12
What is CAISSF?	12
What is CAIVPE?	13
How DataManager Works	14
DataManager Input Sources	14
Online Functions	16
Batch Functions	17
DataManager Output	17
DataManager Concepts and Terms	17
DataManager Terminology	19
System Flow	23
DataManager Rules and Cautions	25
Panels You'll See When Using DataManager	26
The DataManager Primary Panel	27
Action Bar Pull-Downs	30
Scrolling Lists	33
Windowing	34
How Panels Are Connected	39
Function Key Summary	39
Reading Syntax Diagrams	41
Chapter 2: Handling Input Records	47
Input Pull-Down	49
Editing Input Records	51
Input Record Description Panels	51
Input Descriptions List	56
Input Record Definition Panel	58
Browsing Committed Input Records	61
Browse Committed IRDs Panel	62
Commit Input Record Definitions Panel	64

Example 1: Defining Your Own Input Record	65
Example 2: Changing a Record's Length or Description	71
Example 3: Editing Fields in an Existing Input Record	73
Example 4: Deleting Input That PMA Doesn't Use	75

Chapter 3: Handling Output Records **77**

Output Pull-Down	79
Editing Output Records	81
Output Record Description Panel	82
Output Descriptions List	83
Output Record Definition Panel	86
Output Record Header	92
Browsing Committed Output Records	95
Browse Committed ORDs Panel	96
Output Commit Definition Panel	98
Example 1: Defining Your Own Output Record	99
Example 2: Changing an Output Record's Description	104
Example 3: Editing Fields in an Existing Output Record	106
Example 4: Deleting Output That PMA Doesn't Use	108

Chapter 4: Options **111**

Chapter 5: Using Help **115**

Requesting Help	115
The About Window	117
Help Panel Areas	118
Overview	118
Help Function Key Settings	119
Moving Through Help	120
Exiting Help	120
Help Panels	121
Panel Helps	121
Field Helps	123
The Table of Contents Panel	125
Topic Help Panel	127
Index Help Panels	129
The Help for Help Panel	131

Chapter 6: DataManager Batch Processing and Reporting **133**

The Parameter Files	134
---------------------------	-----

CAIKSPAR Parameter File	134
CAIKSPAR Usage Considerations	136
The Archive/Restore Program (CAKSARCH)	136
JCL for Running the CAKSARCH Program	137
The BACKUP Option	138
The RESTORE Option	142
The COMMIT Option	146
The COPY Option	151
How COPY and COMMIT Impact Tables	153
The CA Netman Data Convertor (CAKSNET8 and CAKSNET9)	155
Designating a Date and Time	155
DDNAMEs Required by This Step	155
The JCL for Running CAKSNET8	156
Output From CAKSNET8	156
DataManager Daily Processing (CAKSLOAD)	157
Daily Processing Options	157
Processing Requirements	163
Processing Recommendations	163
Preparation Overview	164
JCL for Running Daily Processing	165
The CA\$KREX User Exit for CAKSLOAD	169
Daily Processing Output	171
The CA Earl Print Job	173
JCL for Running CA Earl Reports	174
CA Earl Output	175

Chapter 7: DataManager Security and Audit **177**

CA Top Secret Security	177
CA ACF2 Security	178
RACF Security	179

Appendix A: DataManager Panel Displays **181**

Appendix B: Predefined CA JARS History Records **185**

Appendix C: DataManager Tables **189**

IRDDDESC Table	189
IRDTAB Table	189
OPTTAB Table	190
ORDDESC Table	190
ORDTAB Table	190

Appendix D: Relationship Between IRD and ORD Formats	193
B Format Input Record Definition	195
C, F, and H Formats Input Record Definition	196
N Format Input Record Definition	197
P and X Formats Input Record Definition	197
Glossary	199
Index	207

Chapter 1: Introduction

CA PMA Chargeback DataManager is a powerful system that prepares input data for use by CA Performance Management and Accounting (PMA) applications. DataManager maps data from a variety of sources into a format that can be used as input to PMA applications.

This guide provides a detailed explanation of DataManager features and functions.

Before using this manual, be sure that:

- DataManager and CA PMA Chargeback have been installed
- You have performed the basic procedures described in the CA PMA Chargeback Installation Guide

Once DataManager is installed, run it to prepare the data used by CA PMA Chargeback.

This section contains the following topics:

[Features](#) (see page 9)

[CA Common Services for z/OS Overview](#) (see page 9)

[How DataManager Works](#) (see page 14)

[DataManager Concepts and Terms](#) (see page 17)

[DataManager Rules and Cautions](#) (see page 25)

[Panels You'll See When Using DataManager](#) (see page 26)

[Reading Syntax Diagrams](#) (see page 41)

Features

DataManager:

- Accepts input from CA JARS®, interfaces, CA JASPER, CA Netman®, and CA VSCHARGE
- Accepts user-defined, fixed-format files as input, providing online facilities to define and store the format of the input file
- Creates an output data set that can be used by any CA PMA application

CA Common Services for z/OS Overview

This section describes the CA Common Services for z/OS.

What is ViewPoint?

ViewPoint is a windowed execution environment for z/OS. CA PMA Chargeback uses some of the ViewPoint components to provide a user interface that uses SAA/CUA standards and offers a **common look and feel** with other CA solutions. This implementation is consistent with the CA Common Services for z/OS guiding principles to endorse and enhance established industry architectures and standards.

ViewPoint facilitates a CA PMA Chargeback user interface that features these interactive techniques:

- pull-down menu access to functions
- direct navigation to multiple, open windows
- prompting facilities that display pop-up windows to assist users entering data

These features are available in monochrome, color or extended attribute color formats. ViewPoint automatically adjusts to the terminal attributes and maximizes the capabilities of the device.

CA PMA Chargeback does not require installation of ViewPoint in its entirety. The CA PMA Chargeback installation procedures include only the ViewPoint components that are needed for CA PMA Chargeback.

What is the CA EARL Service?

The CA EARL (Easy Access Report Language) Service is a user-friendly report definition facility with the power of a comprehensive programming system. CA EARL allows you to modify and print the contents and layout of predefined CA PMA Chargeback reports using English-like statements. The routines which provide this service are grouped under the CA z/OS CA EARL Service code XE60. CA EARL Service features include:

- page, user and field headings
- automatic subtotalling and totaling capabilities
- automatic data editing
- full arithmetic computational facilities
- high-level capabilities
- enhanced printed output control

What is CA LMP?

The CA License Management Program provides a standardized and automated approach to the tracking of licensed software. It uses common realtime enforcement software to validate the user's configuration. CA LMP reports on activities related to the license, usage and financials of CA products. The routines which accomplish this are integrated into the CA z/OS dynamic service code, S910 (the CAIRIM service). CA LMP features include:

- common Key Data Set can be shared among many CPUs
- "check digits" are used to detect errors in transcribing key information
- Execution Keys can be entered without affecting any CA software solution already running
- no special maintenance requirements

What is CAIRIM?

CAIRIM, CAI Resource Initialization Manager, is the common driver for a collection of dynamic initialization routines that eliminate the need for user SVCs, SMF exits, subsystems, and other installation requirements commonly encountered when installing systems software. These routines are grouped under the CA z/OS dynamic service code S910. CAIRIM's features include:

- obtaining SMF data
- verification of proper software installation
- installation of z/OS interfaces
- automatic startup of CA and other vendor products
- proper timing and order of initialization

What is the CA SRAM Service?

The CA SRAM (Sort Reentrant Access Method) Service is a complete replacement for conventional methods of invoking a sort system from high-level languages. CA SRAM allows the activation of several sorts concurrently, thereby simplifying the data and logic flow. The incoming data to the sort can be manipulated as desired by the user program in a high-level language without the need for special exit routines. The service routines which accomplish this are grouped under the CA z/OS service code SR66. CA SRAM's features include:

- all loaded modules are coded to be completely reentrant
- sorts in ascending or descending sequence
- accepts fixed and variable length records
- allows key definitions to spread out over the record
- low overhead
- operating system independence

What is CAISSF?

CAISSF, CAI Standard Security Facility, allows CA PMA Chargeback to offer standardized security interfaces without regard for the particular needs of underlying access control software. CAISSF offers user authentication and resource access validation facilities, and can interface with CA security solutions (CA ACF2 or CA TOP SECRET) or compatible non-CA security products. CAISSF is a subservice contained within the CA z/OS service code S910 (CAIRIM). For CA security products, CAISSF's features include:

- a single security mechanism
- isolation of CA enterprise solutions from CA or vendor mechanisms

For non-CA security products, CAISSF's features include:

- resource class translation
- access level translation
- selective logging of requests
- request type control
- message support for failed access

What is CAIVPE?

CAIVPE (Virtual Processing Environment) is an interproduct service used by CA solutions running under CA ROSCOE, TSO or CICS. It contains monitor-specific code and allows CA solutions to run independently of the environment. The routines which accomplish this are grouped under the CA z/OS service code, WU40. CAIVPE's features include:

- making environment inquiries
- making terminal inquiries
- reading/writing directly from/to sequential files
- performing upper/lower case translation
- issuing messages to both terminal and console
- checking runaway tasks
- dumping application-specific storage before giving control to the operating system

How DataManager Works

DataManager Input Sources

DataManager can be adapted to process your own data or data produced by:

- CA JARS-related products and interface output files including the following:
 - Advantage™ for ADABAS
 - Advantage™ CA Datacom®/DB
 - BrightStor™ CA Dynam®/TLMS
 - Advantage™ CA IDMS®/DB
 - CA JARS DSA
 - CA MAZDAMON
 - CA Roscoe®
 - CA 1®
 - CICS
 - DB2
 - IMS
 - MVS - Batch
 - NETVIEW
 - VAX
 - VM
- CA JASPER: JSPSMF Glossary File
- CA Netman R318, R319
- CA VSCHARGE: VGENJOB output file
- ROLM

For your convenience, DataManager provides input and output definitions for all these record types. You can also supplement them with records you create using DataManager's online component. This record creation capability allows you to process input from flat files with fixed-format records. As a result, DataManager has the flexibility to handle data from numerous sources, so your PMA applications can be as comprehensive in scope as you require. A given product and/or interface may have multiple input/output definitions associated with it. Refer to Appendix B, "Predefined Input and Output Records," for details.

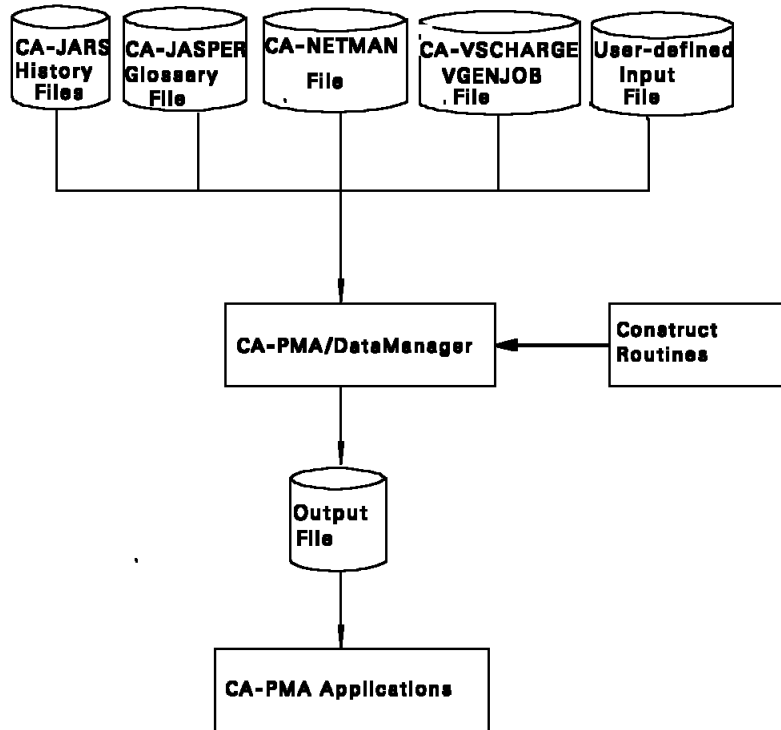

DataManager prepares data from many sources for use by PMA applications

Online Functions

DataManager allows you to perform several types of functions at your terminal:

Input Functions

Enables you to define the format of all input records read by DataManager.

Output Functions

Let you define the format of output records generated by DataManager. Every output data field is derived from some input field. Each output definition also includes a construct which identifies the PMA application this record pertains to.

Options

Specify the options that you want in effect during the current online session. This includes whether or not you want to use mnemonics, or have warning messages and Save/Delete windows displayed.

The online facilities of DataManager streamline the data management process by:

- defining new input and output records
- validating the correspondence between input and output records
- tailoring existing records
- supporting dual environments: production and test

To help you get the job done faster, these panels provide state-of-the-art features such as:

- action bars
- pull-downs
- fast paths
- windowing

Batch Functions

DataManager also has a batch component which performs the following tasks:

Commit Processing

Takes input and output definitions you've been editing, cross-checks them, and makes them available for production.

Load Processing

Reads input from a variety of sources and creates an output file containing usage information. The contents of that file depends on the output record definitions stored in the DataManager database. This output file becomes input for all PMA applications.

Print Processing

Lists the data records created by the last CAKSLOAD job that ran.

Archive, Copy, or Restore Processing

Handles database maintenance.

DataManager Output

DataManager output falls into the following categories:

- Printed output from batch jobs
- An output file which becomes input to other PMA applications
- A listing of newly created DataManager output records
- A file of Advantage™ CA Earl® statements
- A database containing all your input and output definitions

DataManager Concepts and Terms

DataManager builds a *relational database* that consists of definition *tables* which are two-dimensional arrays of rows and columns. Each row stores a separate record. Each column has a name (like City, State or Zipcode) and stores similar data values (numeric or character, for example). Columns are often referred to as *fields*.

Here is a sample table:

	CITY	STATE	ZIPCODE
Row 1	Boston	MA	02120
Row 2	New York	NY	10016
Row 3	Dallas	TX	75217
Row 4	Phoenix	AZ	85012

Definition Tables contain records that describe DataManager's input and output.

Table Name

Description

IRDESC

(Input Record Description Table): Specifies the description, record length, and record name for every defined input record.

IRDTAB

(Input Record Definitions Table): Specifies the definition for each field within an input record.

ORDESC

(Output Record Description Table): Specifies the description of each output record, including the name of the input record from which it is derived.

ORDTAB

(Output Record Definitions Table): Specifies the definition for each field within an output record.

DataManager's online component consists of panels for defining and maintaining the records in these tables. Once you've set up these tables, they require minimal maintenance.

DataManager Terminology

IRD and ORD

DataManager focuses on maintaining tables that contain input and output record definitions, abbreviated as **IRDs** and **ORDs**. These definitions describe every data item or **field** within each record.

IRD Name or ORD Name

Each record definition has a unique identifier called its **name**. Therefore, you refer to a specific record by specifying its IRD Name or ORD Name.

Input ID

When an input file contains more than one kind of input record, DataManager needs to know how to differentiate them. That's the purpose of **Input IDs**. They tell DataManager how to recognize each type of record. For example, if an input data set contains three record types, all three IRD descriptions should include unique Input IDs. Each record description stores the unique value shared by all records of the same type and its location within the record.

Output Record Header

Since DataManager outputs records for Performance Management and Accounting applications, duration of services is of primary importance. For this reason, every output record definition includes a header that specifies an ORD name, start stamp, stop stamp and duration.

Start and Stop Stamps

Consist of date and time fields stored on the IRD. This information specifies when the process described by this record began and ended.

Duration

The name of an IRD field that specifies how long this process ran.

Construct

Some PMA applications require all their input records to have a unique identifier which is called a construct. One construct identifies all the input records for a single application. DataManager appends the construct to its output records.

Note: Only one construct is associated with each application, but output records can contain more than one construct. Therefore, an output record can be input to more than one PMA application.

Commit Processing

The commit process takes the definitions you've been editing and makes them available for production runs. You only run the commit job when you want to "freeze" definitions you've been editing.

Versions

Input and output records you edit belong to the DEVELOPMENT version. When you commit records, their version changes:

- Committed input records belong to the REAL version.
- Committed output records belong to the TEST or PROD version.

Having two versions of committed output definitions allows you to work in two different environments: test and production. The PROD version allows you to keep running daily production jobs while the TEST version lets you test out changes you've made to the production version.

Input Tables

Output Tables

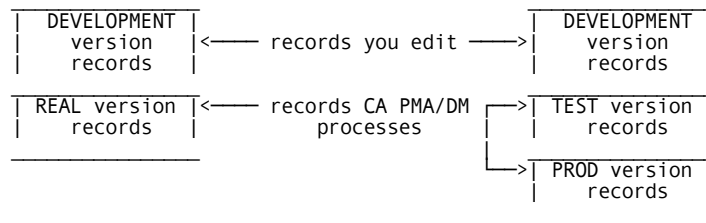

CAIKSPAR Parameter File

The CAIKSPAR file contains information about the database system you use, along with specific DataManager and CA PMA Chargeback parameters. Both products use the CAIKSPAR file for batch processing and online sessions. DataManager accesses CAIKSPAR for all types of processing:

- online definition facility
- COMMIT processing
- DataManager processing

CA-PMA/DataManager System Flow

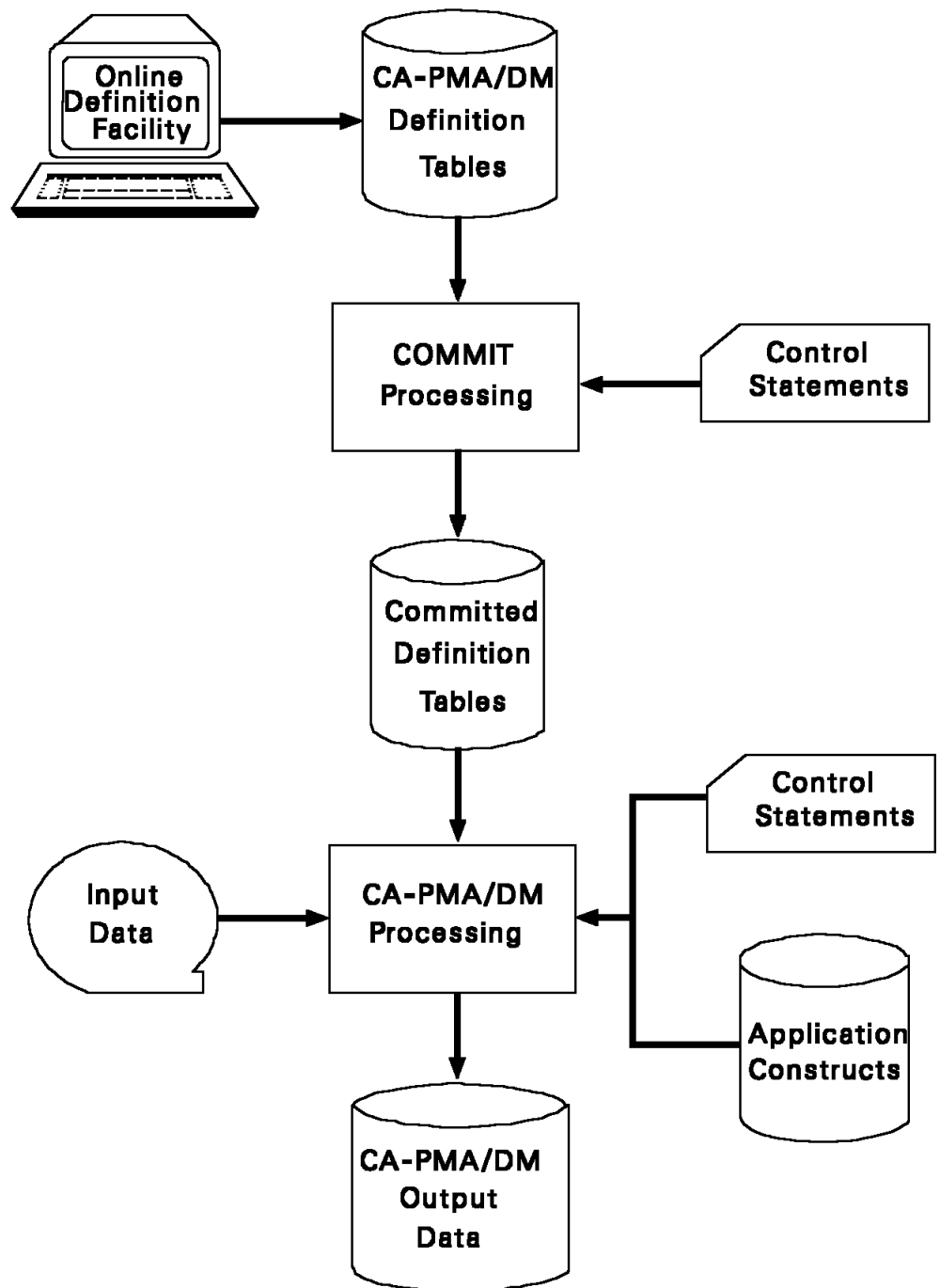

Once input data is processed by DataManager, it is ready for use by PMA applications.

System Flow

The DataManager online facility builds tables that store descriptions and definitions of input and output records. DataManager checks to be sure it knows where to find all the values you've defined as output. DataManager reads an ORD, checks its IRD and verifies that corresponding input fields exist. Every data field on an output record must match up with an input field. This checking is done automatically by the online facility.

When you've finished defining records, you save this version so it can be used by daily production runs. This saving step is the commit process.

DataManager processing consolidates the performance and accounting data collected at your site. The committed IRD and ORD definitions specify what data you want collected. However, because DataManager is a table-driven system, input data **must** be in an acceptable format. Therefore, all input data must be:

- in the form of fixed-format records
- without multiple segments

When DataManager processes this data, it executes a construct program defined by each application. The final output is data ready for further processing by PMA applications.

The commit step is the boundary between two different DataManager environments:

- the workspace that stores the version of definitions that you edit
- the production environment that processes the definitions that you've committed

DataManager lets you work simultaneously in both of these environments. For example, you may decide to include some other data in your chargeback system. To do this, you copy the definitions you're currently using for production and then update them. Meanwhile, production keeps running using the committed definitions. When you're ready to update the production version, run the COMMIT process. DataManager then changes the content of its tables based on the values each record stores in its Version field. For example, committing a new TEST version:

- erases all existing definitions with REAL or TEST Versions
- changes blank Versions (signifying DEVELOPMENT) to
 - REAL in input tables
 - TEST in output tables
- leaves you with no records in the DEVELOPMENT version

Therefore, DataManager allows you to continue development work while daily production jobs continue preparing data for PMA applications.

DataManager Rules and Cautions

How Information is Displayed on CA PMA Chargeback Panels Protected display field areas are preceded by a colon (:). Underscores show the number of allowable characters in an entry field.

Specifying Search Strings

When specifying character strings for searches, use the SQL wildcard % to represent one or more characters. You can specify it anywhere within the search string. For example, to list all ORD (Output Record Definition) names starting with MB, specify MB%. This will yield MBJ, MBP, MBS, and so forth.

System Rules

- When more than one type of input record occurs within a file, define an Input ID in each record's description.
- Remember to check each application's construct requirements.
- Committed definitions cannot be edited, only browsed.

ORDs Require IRDs

- IRDs must be defined before ORDs.
- You must delete ORD fields before deleting the corresponding input fields.
- Always delete output records before input records because DataManager insists that all ORDs have defined IRDs.

When to Scroll

You **must save** your input using F5 before scrolling a panel. If you do not, the data you have entered will be cleared from the panel.

Naming Conventions

- These characters are reserved. Don't use them in IRD or ORD names:
 - % (percent)
 - _ (underscore)
 - ' (single quote)
- IRD names cannot start with a special character.
- ORD names cannot start with a special character or the letter A.
- The ORD field name of CB-CONS is reserved for CA PMA Chargeback's construct definition.
- The ORD field names used in the output record header are also reserved (STARTSTAMP, START-HHMM, STOPSTAMP, STOP-HHMM, DURATION, ORDID).

Panels You'll See When Using DataManager

This section discusses the main entry to DataManager and some general points that are common through the system.

Lets you select values for user options. These values remain in effect until you change them again.

Exit

Ends this DataManager session. Exit pull-down options are:

- Save and exit
- Exit without saving
- Resume

Help

Lets you access different types of Help. Help pull-down options are:

- Index
- Table of Contents
- Help for Help
- About (genlevel)



Fast path entry area: This two-character entry field allows experienced users to specify the *fast path* (no intervening pull-downs or panels) to get to the panel or function they wish to perform. This field exists on every DataManager product panel (not on pull-downs, windows or Help panels). Type in two characters when using the fast path. For example, entering **IC** displays a panel listing committed input definitions.

I

The first character in a fast path entry matches the uppercase letter in an action bar keyword on the Primary Panel. In this case, I for Input or O for Output.

C

Most action bar keywords lead to a pull-down. The second character typed in the fast path area is the first letter of a pull-down option (for example, I for Input Definitions or C for Commit Definitions).

By specifying two letters in the fast path area, you make DataManager skip the pull-down and display the panel you selected. These valid combinations display specific panels.

IC

Browse Committed IRDs panel

II

Input Record Description panel

OC

Browse Committed ORDs panel

OO

Output Record Description panel



Global Message Area: Messages are displayed on the line above the command line and may overlay any information on this line of the panel.



Command Line: Press F9 to move the cursor to the command line and prepare it for input. Then type in commands in this area. Press F4 to view a list of valid commands.

Users working at terminals without F keys rely heavily on commands. F key assignments identify the commands valid on each panel. Rather than typing a command, try tabbing to an F key assignment and pressing Enter. F keys, commands and tabbing all yield the same result. However, the command line offers more possibilities than these other techniques do. For example:

?

Displays the last executed command. Press Enter to re-execute it.

=

Executes the last command again.

=action

Displays that action's pull-down. (Valid only with actions on the Primary panel).

Action Bar Pull-Downs

When you start DataManager, the first panel you see is the **Primary Panel**. Its action bar lets you choose one of five keywords: Input, Output, oPtions, Exit or Help. When you select Input or Output, DataManager displays a list of options available for the selected action bar choice. Selecting the Input keyword on the action bar causes DataManager to display the Input pull-down shown below.

Sample Pull-Down

```
userid          CA PMA/DataManager          mm/dd/yy hh:mm:ss
--      Input  Output  oPtions  Exit  Help
A. |-----|
   |          |
B. |  _1. Input Definitions |
   |  _2. Commit Definitions |
   |-----|
C. |          |
   |          |
Command ==>
F1=Help  F3=Exit  F4=Prompt  F9=Command  F10=Action Bar  F12=Cancel  PA1=Susp
```

A.

Pull-Down: When you select a keyword from the Primary Panel's action bar, DataManager highlights that keyword and its *pull-down* appears against the background of the Primary Panel. This is the Input pull-down.

B.

Entry Area: A one-character field where you enter the number of your option choice. In this case, enter 1 to select Input Definitions or 2 to select Commit Definitions. DataManager gives you an alternate way of choosing an option: simply tab to your choice and press Enter.

C.

Local F Keys: Some F key assignments change from panel to panel. These *local* F keys are shown at the bottom of each panel. Typically, local F keys allow you to scroll back and forth through lists of records.

Selecting either item from this pull-down displays a **description list** that lets you choose specific records. They appear on a **selection list** from which you can pick a record. Selecting one record from a list leads to a panel that displays detailed information about that record. This progression illustrates how DataManager works: *Primary Panel* to *pull-down* to *description list* to *selection list* to *details*.

Now let's look at two pull-downs you'll see frequently when running DataManager: the Panel pull-down and the Exit pull-down.

The Panel Pull-Down

All panels that you access from pull-downs contain a keyword called Panel in their action bars. Use this option to control how DataManager displays these panels.

Panel Pull-Down

```

userid                               CA PMA/DataManager                               mm/dd/yy hh:mm:ss
--   Input  Output  oPtions  Exit  Help
+   DMIDESP  _____ Input Record Description _____
|   ❶ Panel  Exit  Help
|   _____
|   Ent      _____ rd Description or Browse IRDs
|   |
|   |   ❷ Panel
|   |
|   |   D
|   |   I   - 1. Move
|   |   F2  - 2. Suspend
|   |
|   +   ❸
+-----+-----+-----+-----+-----+
Command ==>
F1=Help  F3=Exit  F4=Prompt  F9=Command  F10=Action Bar  F12=Cancel

```

❶

Each time you select a keyword from an action bar, DataManager overlays that panel with another panel. Since the new panel's action bar is now active, you can choose Panel, Exit or Help.

❷

Choosing Panel displays a pop-up window that provides you with the following options:

- **Move** gives you instructions on how to reposition panels on the screen.
- **Suspend** allows you to freeze a panel on your screen, making it inactive but visible. The other panels you display will overlay suspended panels. By suspending one panel and then another, you can toggle back and forth between them.

Note: Windows may also extend beyond the screen's edge. However, you cannot enter data into fields that aren't completely contained on the screen.

❸

Message Line: DataManager displays messages on the line below the local F keys on all windows. Messages overwrite the bottom border of the box.

The Exit Pull-Down

The Exit pull-down always appears when you select the Exit keyword from an action bar. It conditionally appears when you press F3 (Exit). If you select this keyword without first saving your changes, DataManager displays an Exit pull-down that looks like this.

Exit Pull-Down

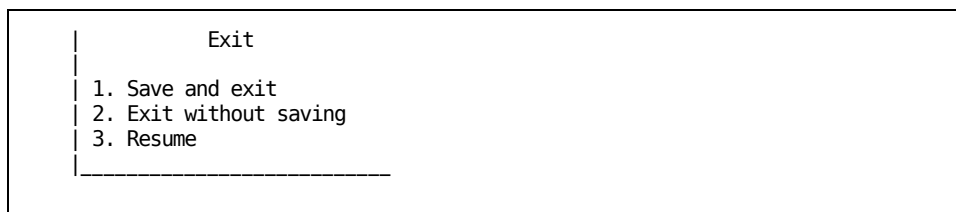

Exit pull-downs provide you with the following choices:

- **Save and exit** lets you back out one panel at a time, saving any changes or entries.
- **Exit without saving** lets you back out one panel at a time without saving any changes or entries.
- **Resume** lets you carry on as though you never selected Exit.

Scrolling Lists

Lists all have a line called the *scroll bar* which serves several purposes:

```
userid          CA PMA/DataManager          mm/dd/yy hh:mm:ss
  Input  Output  oPtions  Exit  Help
+ DMIDESL  Input Descriptions List
  Panel  Exit  Help
-----
Select input description name. Then Enter.

                                More: - + ____ Row 0001 of 0062

  DD Name  IRD      Description      Rec  Hex
           Name
- JASPER   JAV              00088
- JASPER   JAT              00109
- JASPER   JAS              00128
- JASPER   JAR              00251
- JASPER   JAQ              00112

Enter  F7=Bkwd  F8=Fwd  F11=Description
-----
Command ==>
F1=Help  F3=Exit  F4=Prompt  F9=Command  F10=Action Bar  F12=Cancel  PA1=Susp
```

- It tells you your location within a list. In this case, the first item on your panel is at the top of a list that consists of three items.

```
| More: - + ____ Row 0001 of 0003 |
```

- To view a specific row, type its number in the Row entry area and press Enter. That row will appear at the top of the list.

```
| More: - + ____ Row 0050 of 0100 |
```

- To scroll backward and forward a specific number of rows, type the number of rows you want to scroll in the entry area following the - (minus) and + (plus) symbols and press F7 or F8 to indicate the scrolling direction.

```
| More: - + ____ Row nnnn of 0003 |
```

The entry area following the - (minus) and + (plus) symbols also lets you control scrolling increments:

```
| More: - + ____ Row nnnn of 0003 |
```

- a specific *number* of rows you want to scroll

```
| More: - + nnnn Row 0001 of 0003 |
```

- *page* only displays new lines each time you scroll

```
| More: - + page Row 0001 of 0003 |
```

- *data* repeats just the first or last line on the next panel

```
| More: - + data Row 0001 of 0003 |
```

- *csr* (cursor) moves the line containing the cursor to the top or bottom of the list

```
| More: - + csr_ Row 0001 of 0003 |
```

Then move the cursor to + or - (to indicate the direction you want to scroll in) and press Enter.

Windowing

When running the online component of DataManager, you'll encounter several types of pop-up windows. Pop-up windows are different than pull-downs:

- Pull-downs have action bars, but pop-up windows don't.
- Pop-up windows can appear when needed, not only when called.
- Pop-ups cannot be moved.

The following functions can be used when windows are displayed: HELP, EXIT, CANCEL, SUSP. The other functions (PROMPT, COMMAND, ACTION BAR) are inactive while windows are displayed.

This section focuses on several types of prompt windows, the About window, and the Redefine window.

The Are You Sure? Window (The Delete Prompt)

The oPTIONS keyword on the Primary panel's action bar determines whether or not you want Delete prompts displayed.

```
userid          CA PMA/DataManager          mm/dd/yy hh:mm:ss
--            Input Output oPTIONS Exit Help
+-----+-----+-----+-----+-----+
+-----+-----+-----+-----+-----+
| Update options. Then Save.
| Warning Msgs . . . . ___ Mnemonics . . . . ___
| Info Msgs . . . . ___ Action Bar . . . . ___
| Save/Delete Prompt . BOTH Database Depth . . 500
| PF13-24 = PF1-12 . . ___
|
| F5=Save
+-----+-----+-----+-----+
Command ==>
F1=Help F3=Exit F4=Prompt F9=Command F10=Action Bar F12=Cancel PA1=Susp
```

The list below explains every valid value for the Save/Delete Prompt field. The default is BOTH. The value you specify determines whether or not the Delete prompt (also known as the **Are You Sure** window) appears.

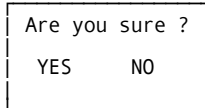

SAVE

Only the SAVE prompt will be displayed.

DEL

Only the DELeTe prompt will be displayed.

BOTH

Both the SAVE and DELeTe prompts will be displayed.

OFF

Suppresses save and delete messages.

To view **Are You Sure** windows, select DEL or BOTH. Let's assume you kept the default value, BOTH. Whenever you attempt to delete fields or records, DataManager displays this window so you can cancel the delete if it was a mistake. To cancel a delete, tab to NO and press Enter. To authorize a delete, just press Enter.

About (Genlevel) Window

To verify the genlevel of the CA PMA product you are using, you must select Help from the Primary Panel's action bar and then select **About**. This causes a window to appear that contains the genlevel of this product.

The Data Has Not Been Saved Window (The Save Prompt)

The oPTIONS action on the Primary Panel controls whether or not the Save prompt appears.

```

userid          CA PMA/DataManager          mm/dd/yy hh:mm:ss
--             +-----+-----+-----+
+   Input  Output  oPTIONS  Exit  Help
+   DMOPTNS _____ User Options _____ +
+   Panel  Exit  Help
+-----+-----+-----+
| Update options. Then Save.
| Warning Msgs . . . . ____ Mnemonics . . . . ____
| Info Msgs . . . . ____ Action Bar . . . . ____
| Save/Delete Prompt . BOTH Database Depth . . 500
| PF13-24 = PF1-12 . . ____
|
| F5=Save
+-----+-----+-----+
Command ==> _____
F1=Help F3=Exit F4=Prompt F9=Command F10=Action Bar F12=Cancel PA1=Susp

```

The list below explains every valid value for the Save/Delete Prompt field. The default is BOTH.

SAVE

Only the SAVE prompt will be displayed.

DEL

Only the DELeTe prompt will be displayed.

BOTH

Both the SAVE and DELeTe prompts will be displayed.

OFF

Suppresses save and delete messages.

```

Data has not been saved
_ 1. Save and exit
_ 2. Exit without saving
_ 3. Resume

```

How Panels Are Connected

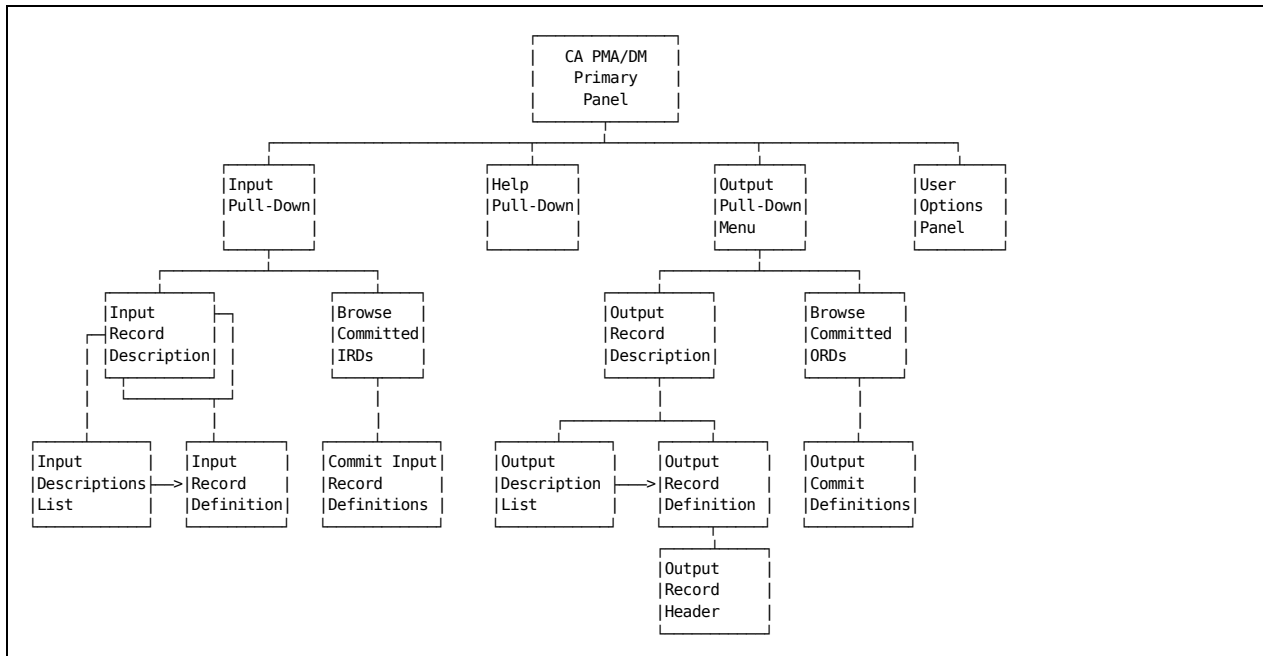

All panels descend from the Primary Panel and its pull-downs. Committed definitions can only be browsed. Most editing occurs on the Input and Output Record Definition panels which are accessed from IRD and ORD Description Lists.

Behind each of these panels is a HELP panel that explains how things work. For example, if you press F1 when you're in the Input Record Definition panel, this HELP panel appears:

```

+__ DMIDESEH _____ INPUT RECORD DEFINITION _____ HELP ___+
@
@ The Input Record Definition panel (BAIDESE) enables you to edit
@ the Input Record Definitions stored in the IRDTAB table.
@
@ With this panel you can define new fields; change existing field
@ definitions; delete individual fields or the entire input record
@ definition.
@
@ When building new input records, define each field the PMA application
@ will use. Remember to SAVE (F5) before scrolling or exiting this panel.
@

```

Function Key Summary

Function keys allow you to navigate through DataManager panels and perform various actions. Some function keys apply to all panels while others are panel-specific.

Global Function Keys

The following global function key assignments appear on the DataManager Primary Panel and apply to every panel, even when they are not displayed.

F1=Help

Displays the Help pull-down (see chapter 5, "Using Help").

F3=Exit

Returns to the preceding panel if the changes you made to this panel have been saved. Pressing F3 on the Primary panel ends this DataManager session.

F4=Prompt

Displays a pop-up window that lists valid choices for the entry field your cursor is currently pointing at. To choose an entry, tab to your selection and press Enter. DataManager then displays this entry in the appropriate field as if you'd typed it there. F12 lets you erase this pop-up window without making a selection.

Note: If you request a prompt when the cursor is **not** on an entry field, nothing happens. All entry fields will either display a choices list or a descriptive message when you press F4.

F9=Command

Positions the cursor at the command line and prepares the command line for input.

F10=Action Bar

Positions your cursor at the action bar and allows you to tab to your selection.

F12=Cancel

Erases the current panel without saving changes made to this panel.

PA1=Susp

Lets you suspend processing for the currently active panel and activate the global action bar.

Local Function Keys

Local function keys only work for the panel that displays them. Each panel description in chapters 2-4 explains how its local function keys work.

Reading Syntax Diagrams

The formats of all statements and some basic language elements are illustrated using syntax diagrams. Read syntax diagrams from left to right and top to bottom.

The following terminology, symbols, and concepts are used in syntax diagrams.

Keywords

Appear in uppercase letters, for example, COMMAND or PARM. These words must be entered exactly as shown.

Variables

Appear in italicized lowercase letters, for example, *variable*.

Required Keywords and Variables

Appear on a main line.

Optional Keywords and Variables

Appear below a main line.

Default Keywords and Variables

Appear above a main line.

Double Arrowheads Pointing to the Right

Indicate the beginning of a statement.

Double Arrowheads Pointing to Each Other

Indicate the end of a statement.

Single Arrowheads Pointing to the Right

Indicate a portion of a statement, or that the statement continues in another diagram.

Punctuation Marks or Arithmetic Symbols

If punctuation marks or arithmetic symbols are shown with a keyword or variable, they must be entered as part of the statement or command. Punctuation marks and arithmetic symbols can include:

, comma	> greater than symbol
. period	< less than symbol
(open parenthesis	= equal sign
) close parenthesis	¬ not sign
+ addition	- subtraction
* multiplication	/ division

The following is an example of a statement without parameters.

Statement Without Parameters

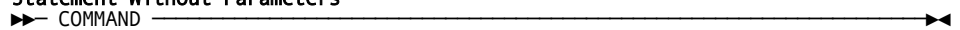

You must write:

COMMAND

Required parameters appear on the same horizontal line (the main path of the diagram) as the command or statement. The parameters must be separated by one or more blanks.

Statement With Required Parameters

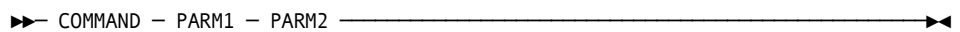

You must write:

COMMAND PARM1 PARM2

Delimiters such as parentheses around parameters or clauses must be included.

Delimiters Around Parameters

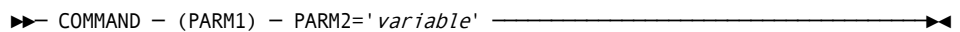

If the word "variable" is a valid entry, you must write:

COMMAND (PARM1) PARM2='variable'

Where you see a vertical list of parameters as shown in the following example, you must choose one of the parameters. This indicates that one entry is required and only one of the displayed parameters is allowed in the statement.

Choice of Required Parameters

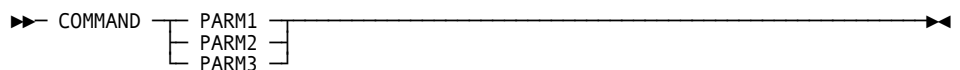

You can choose one of the parameters from the vertical list, such as in the following examples:

```
COMMAND PARM1
COMMAND PARM2
COMMAND PARM3
```

When a required parameter in a syntax diagram has a default value, it indicates the value for the parameter if the command is not specified. If you specify the command, you must code the parameter and specify one of the displayed values.

Default Value for a Required Parameter

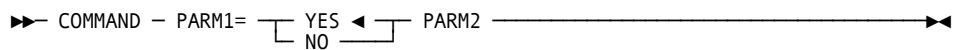

If you specify the command, you must write one of the following:

```
COMMAND PARM1=NO PARM2
COMMAND PARM1=YES PARM2
```

A single optional parameter appears below the horizontal line that marks the main path.

Optional Parameter

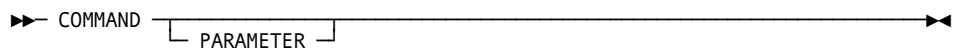

You can choose (or not) to use the optional parameter, as shown in the following examples:

```
COMMAND
COMMAND PARAMETER
```

If you have a choice of more than one optional parameter, the parameters appear in a vertical list below the main path.

Choice of Optional Parameters

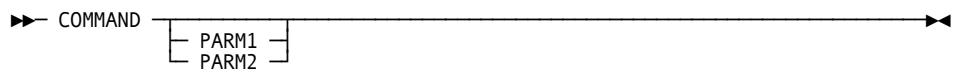

You can choose any of the parameters from the vertical list, or you can write the statement without an optional parameter, such as in the following examples:

```
COMMAND  
COMMAND PARM1  
COMMAND PARM2
```

For some statements, you can specify a single parameter more than once. A repeat symbol (a backward-pointing arrow above the main horizontal line) indicates that you can specify multiple parameters. The following examples include the repeat symbol.

Repeatable Variable Parameter

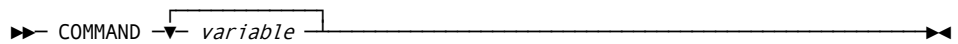

In the above example, the word "variable" is in lowercase italics, indicating that it is a value you supply, but it is also on the main path, which means that you are required to specify at least one entry. The repeat symbol indicates that you can specify a parameter more than once. Assume that you have three values named VALUEX, VALUEY, and VALUEZ for the variable. Some of your choices are:

```
COMMAND VALUEX  
COMMAND VALUEX VALUEY  
COMMAND VALUEX VALUEX VALUEZ
```

If the repeat symbol contains punctuation such as a comma, you must separate multiple parameters with the punctuation. The following example includes the repeat symbol, a comma, and parentheses.

Separator with Repeatable Variable and Delimiter

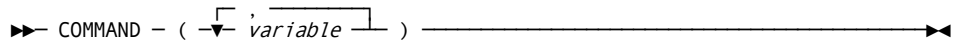

In the above example, the word "variable" is in lowercase italics, indicating that it is a value you supply. It is also on the main path, which means that you must specify at least one entry. The repeat symbol indicates that you can specify more than one variable and that you must separate the entries with commas. The parentheses indicate that the group of entries must be enclosed within parentheses. Assume that you have three values named VALUEA, VALUEB, and VALUEC for the variable. Some of your choices are:

```
COMMAND (VALUEC)
COMMAND (VALUEB,VALUEC)
COMMAND (VALUEB,VALUEA)
COMMAND (VALUEA,VALUEB,VALUEC)
```

The following example shows a list of parameters with the repeat symbol.

Optional Repeatable Parameters

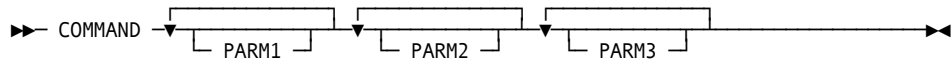

Some choices you can make include:

```
COMMAND PARM1
COMMAND PARM1 PARM2 PARM3
COMMAND PARM1 PARM1 PARM3
```

When a parameter in a syntax diagram is above the line, for example, YES in the following diagram, its special treatment indicates it is the default value for the parameter. If you do not include the parameter when you write the statement, the result is the same as if you had actually specified the parameter with the default value.

Default Value for a Parameter

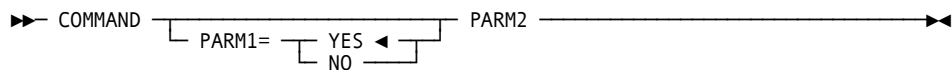

Because YES is the default in the example above, if you write:

COMMAND PARM2

you have written the equivalent of:

COMMAND PARM1=YES PARM2

In some syntax diagrams, a set of several parameters is represented by a single reference, as in this example:

Variables Representing Several Parameters

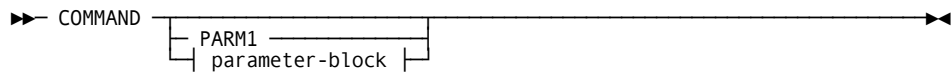

Expansion of parameter-block

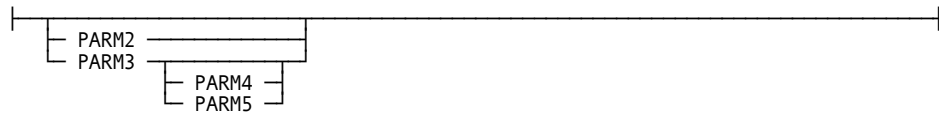

The "parameter-block" can be displayed in a separate syntax diagram.

Choices you can make from this syntax diagram therefore include (but are not limited to) the following:

COMMAND PARM1
COMMAND PARM3
COMMAND PARM3 PARM4

Note: Before you can specify PARM4 or PARM5 in this command, you must specify PARM3.

A note in a syntax diagram is similar to a footnote except that the note appears at the bottom of the diagram box.

Syntax Note

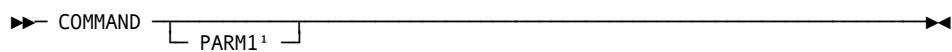

¹ This is a note about the item.

Chapter 2: Handling Input Records

DataManager contains several panels that maintain the information stored in the IRDESC and IRDTAB tables. These tables describe the various types of input that DataManager processes, namely records created by other products like CA JARS, CA JASPER, CA Netman, and CA VSCHARGE. The following panels allow you to maintain input information online:

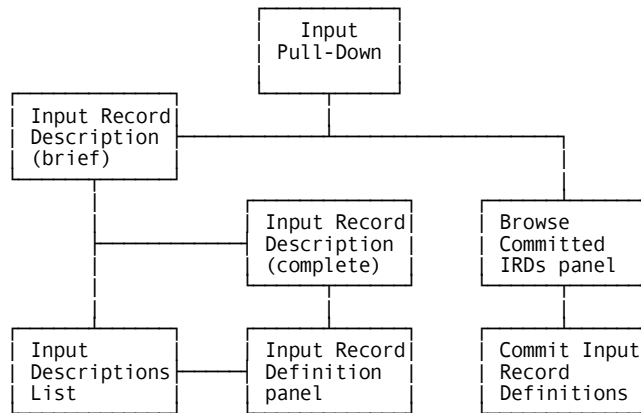

- The **Input** pull-down is the entry panel for accessing input records. This pull-down lets you access two groups of records:
 - those that you can edit (the DEVELOPMENT version)
 - those which have been committed for production use
- The **Input Record Description** panels let you define input of your own, change descriptions of existing records, or list selected records.
- To select a record you want to edit, use the **Input Descriptions List**.
- The **Input Record Definition** panel lets you define new records or edit existing records.

When focusing on committed records, the Input Pull-Down leads to two panels:

- The **Browse Committed IRDs** panel lists committed records you can select for closer examination.
- The **Commit Input Record Definitions** panel displays the content of the committed record you selected.

This chapter provides detailed explanations of these panels followed by examples that show how to:

- define your own input record
- change a record's length or description
- edit fields in an existing input record
- delete input that your PMA applications don't use

Input Pull-Down

This pull-down allows you to access two distinctly different groups of records:

- Option 1 accesses the records you can edit (the DEVELOPMENT version).
- Option 2 lets you look at those input records you've committed (the REAL version).

Committed records can't be edited as is. To make changes to committed records, you must first copy them to the DEVELOPMENT version (see The COPY Option).

Input Pull-Down

```

userid          CA PMA/DataManager          mm/dd/yy hh:mm:ss
--      Input  Output  options  Exit  Help
-----
          Input
          -----
          1. Input Definitions
          2. Commit Definitions
          -----
          F12=Cancel
          -----
Command ==>
F1=Help  F3=Exit  F4=Prompt  F9=Command  F10=Action Bar  F12=Cancel  PA1=Susp

```

Access

The Input pull-down appears when one of these events occurs:

- You type I in the fast path area of the Primary Panel's action bar.
- You choose Input from the Primary Panel's action bar.

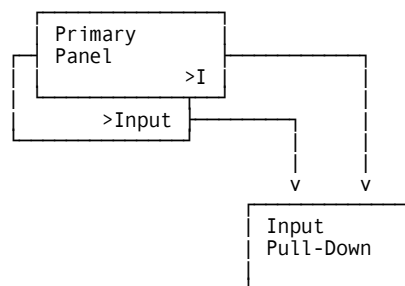

Editing Input Records

This section describes the panels that allow you to edit existing input records and enter new ones. Panels are described in the order you'll see them. Each panel description:

- tells what that panel is used for
- explains how to access that panel
- tells what values to enter into its input fields
- lists the actions this panel can perform
- describes the different exit pathways you can follow

Input Record Description Panels

These panels collect information that DataManager uses to identify the different types of input records. Every input file stores at least one type of input record. Each type of input record requires its own Input Record Description. When an input file contains more than one kind of input record, DataManager needs to know how to differentiate them. That's the purpose of an **Input ID**.

Here is a list of sample input record types:

DD Name	IRD Name	Define Input ID?
JARS	DFB	Yes
JARS	DIB	Yes
JARS	DJR	Yes
JARS	MBJ	Yes
OURDATA	OURSITE	No

Rule:

When an input file contains more than one type of input record, each of those Input Record Descriptions needs to specify an Input ID which identifies a unique code that occurs in a certain place in this type record.

The Brief Form of the Input Record Description Panel

The first Input Record Description panel you see really serves two purposes: it can begin to define a new input record description, or it can request a list of input records that already exist.

Input Record Description Panel (brief)

```

userid          CA PMA/DataManager          mm/dd/yy hh:mm:ss
  Input  Output  oPtions  Exit  Help
+-- DMIDESP -----Input Record Description -----
| Panel  Exit  Help
| -----
| | Enter a New Input Record Description or Browse IRDs
| |
| | DD Name . . . . . OURDATA
| | IRD Name . . . . . OURSITE_
| |
| | F2=Create   F11=Browse
| |
+-----+
Command ==>
F1=Help  F3=Exit  F4=Prompt  F9=Command  F10=Action Bar  F12=Cancel  PA1=Susp
    
```

- Use this panel to select which records you want listed. For example, list all existing input records in the DEVELOPMENT version by typing the SQL wildcard (%) in each of these fields and pressing F11. To display all the records defined for a single data set, specify that ddname and type % for IRD Name. To display all the records that start with the letter J, type % for DD Name, J% for IRD Name and press F11. F11 displays the Input Descriptions List panel.
- To begin defining a new input record, fill in this panel and press F2. This displays the complete Input Record Description panel (see The Complete Input Record Description Panel).

Access

The Input Record Description panel appears when one of these events occurs:

- You choose **1. Input Definitions** from the Input pull-down.
- You type II in the fast path area of the Primary Panel's action bar.
- You return from the Input Descriptions List.

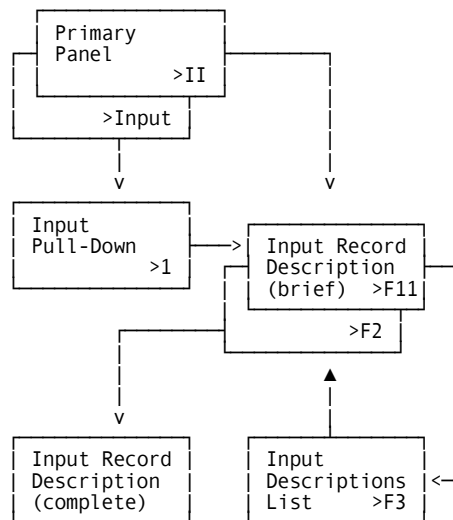

Input

The following fields on the Input Record Description panel are available for input:

DD Name

An internal ddname for the data set where this record is stored.

IRD Name

A name of up to eight alphanumeric characters that you assign to this input record.

Actions

F2

(Create) Displays the complete Input Record Description panel so you can define a new record for the IRDDDESC table.

F11

(Browse) Displays the Input Descriptions List.

The Complete Input Record Description Panel

This is the complete form of the Input Record Description panel. Note that you don't need to define an Input ID for files that contain just one record type.

```

userid          CA PMA/DataManager          mm/dd/yy hh:mm:ss
  Input  Output  oPtions  Exit  Help
+-- DMIDESD -----Input Record Description -----
| Panel  Exit  Help
|-----
| Enter Input Record Description
|
| DD Name . . . . : OURDATA
| IRD Name . . . . : OURSITE
|
| Description . . . OUR PERFORMANCE DATA
| Length of Record . 80
| Input ID
| Starting Position _____
| ID Length . . . . --
| ID Hex Value . . _____
|
| F5=Save  F11=Definition
|-----
Command ==> _____
F1=Help  F3=Exit  F4=Prompt  F9=Command  F10=Action Bar  F12=Cancel  PA1=Susp
  
```

Access

The complete Input Record Description panel appears when one of these events occurs:

- You choose **1. Input Definitions** from the Input pull-down, fill in the panel and press F2.
- You type II in the fast path area of the Primary Panel's action bar, fill in the panel and press F2.
- You point to a description on the Input Descriptions List and press F11.

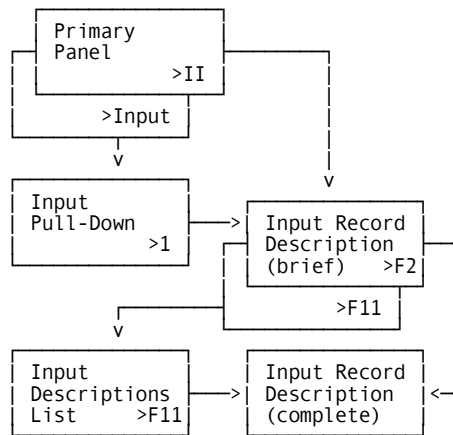

Input

Description

Up to 20 characters describing this input record. (optional)

Length of Record

The total length of the input record.

Starting Position

The column number where this record's input ID begins.

ID Length

The number of characters in the input ID.

ID Hex Value

The unique hex value found in this record's input ID field.

Actions

F5

(Save) Saves your changes and additions to this panel.

F11

(Definition) Displays the Input Record Definition panel.

Input Descriptions List

This panel displays a list of the records in the IRDESC table. Each row describes one type of input record.

Use this panel to:

- scroll through the descriptions list or
- select a particular record for editing

Point the cursor at the record you want to select. Then press F11 to edit that record's description or press Enter to edit that record's field definitions.

```

userid                               CA PMA/DataManager                               mm/dd/yy hh:mm:ss
__  Input Output oPtions Exit Help
+-- DMIDESL --- Input Descriptions List -----+
| Panel Exit Help                               |
|-----|
| Select input description name. Then Enter.    |
|                                         More: - + ____ Row 0001 of 0001 |
|      DD Name  IRD      Description          Rec   Hex  |
|      JARS     MBS     MVS BATCH STEP        608   Val  |
|      -        -        -                    -    -    |
|      -        -        -                    -    -    |
|      -        -        -                    -    -    |
|      -        -        -                    -    -    |
|      -        -        -                    -    -    |
|      Enter   F7=Bkwd  F8=Fwd   F11=Description |
+-----+
Command ==>
F1=Help  F3=Exit  F4=Prompt  F9=Command  F10=Action Bar  F12=Cancel  PA1=Susp
    
```

Access

The Input Descriptions List panel appears when one of these events occurs:

- You choose **1. Input Definitions** from the Input pull-down, type in selection criteria, and then press F11.
- You type II in the fast path area of the Primary Panel's action bar and press Enter.; type in selection criteria; and then press F11.
- You return from the Input Record Definitions panel.

Scrolling

F7 and F8 let you scroll backward and forward through the Input Descriptions List. You can also use the scroll bar, as explained in Scrolling Lists, to move through the list.

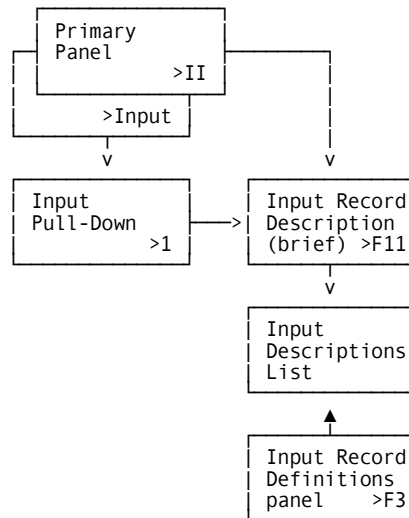

Pathways

F3

(Exit) Returns to the brief Input Record Description panel where you can select another group of records.

Enter

By pointing the cursor at a specific record and pressing **Enter**, you display the Input Record Definition panel. That panel allows you to examine and optionally update the selected record.

F11

(Description) Returns to the complete Input Record Description panel where you can select another group of records.

Input Record Definition Panel

This is the panel where you edit the Input Record Definitions stored in the IRDTAB table. This panel lets you:

- define new fields
- change existing field definitions
- delete individual fields or the entire input record definition

This panel includes protected display fields that carry over from the Input Record Description panel.

When building new input records, define each of the fields your PMA applications will use. This includes the date and time fields DataManager requires as Output Record Header information. DataManager expects these fields to have certain Atr values:

- Dates can use any style date (D, M, Y, J, DC, MC, YC, or JC).
- Times and Durations use Atr values of T, S, N, or H.

Input Record Definition Panel (update mode)

```
userid          CA PMA/DataManager          mm/dd/yy hh:mm:ss
  Input Output oPtions Exit Help
+- DMIDESE ----- Input Record Definition -----
| Panel Exit Help
|-----
| DD Name . . . . : JARS
| IRD Name . . . . : LEVEL7          More: - + ____ Row: 0001 of 0006
| Description . . : LEVEL7 HISTORY REC
| CMD Field Name      Description          Fmt Atr Offset Len Prc
|-----
| -  JOBNAME          JOB NAME             C   1   8   --
| -  STARTDATE       JOB START DATE        N  DC  9   8   --
| -  STARTTIME       JOB START TIME        N   T  17  6   --
| -  STOPDATE        JOB END DATE         N  DC  23  8   --
| -  STOPTHME        JOB END TIME         N   T  31  6   --
| -  ELAPSEDTIME     ELAPSED TIME         N   S  37  8   5
|-----
| F2=Sort  F5=Save  F6=Delete  F7=Bkwd  F8=Fwd
+------
Command ==>
F1=Help  F3=Exit  F4=Prompt  F9=Command  F10=Action Bar  F12=Cancel  PA1=Susp
```

The first time this panel appears, you are in **insert** mode; the Cmd column is blank, the scroll bar doesn't reflect a row count, and the only active function keys are F5, F7 and F8. When you press F5 (Save), a message tells you that the insert was successful. Now you are in **update** mode. The scroll bar provides a row count, the Cmd column is active (lines appear in the column), and **all** function keys are active. Pressing F5 (Save) displays a message that says update was successful.

Access

The Input Record Definition panel appears when one of these events occurs:

- You type II in the fast path area of the Primary Panel; fill in the brief Input Record Description panel; press F2.; fill in the complete Input Record Description panel and press F5.
- You choose Input on the Primary Panel's action bar and select **1. Input Definitions** on the Input pull-down. Then you type in selection criteria, press F11 to browse existing records, tab to a record and press Enter.

Scrolling

F7 and F8 let you scroll backward and forward through the Input Record Definition list. You can also use the scroll bar, as explained in Scrolling Lists, to move through the list.

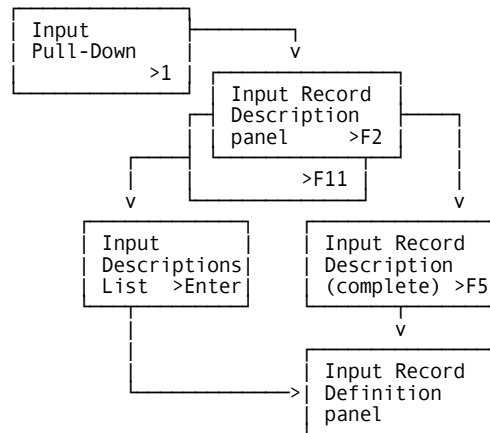

Caution: You **must save** your entries using F5 before scrolling the panel. If you do not, the data you have entered isn't saved and is erased from the panel.

Input

CMD

Delete fields by typing a D in this column and pressing Enter. Then confirm the deletion by responding YES in the confirmation window that appears.

Field Name

The name of an input field. Field names must be unique within each record, but different records can have fields with the same name.

Description

Up to 20 characters that describe this input field. (optional)

Fmt

How data values are stored. Type the following letters to specify the format:

- B binary
- H hexadecimal numeric
- C character
- P packed
- N numeric
- X hexadecimal
- F flag

Atr

The format of date or time fields:

M	mmddy	(American)	H	hhhh	(duration)
D	ddmmy	(European)	N	mmm	(duration)
Y	yymdd	(normalized part)	S	sss	(duration)
J	yyddd	(Julian)	T	hhmmss	
MC	mmddyyy				
DC	ddmmyyy				
YC	yyyymmdd	(normalized full)			
JC	yyyddd				

Valid with Fmt B, N, P, H or C. However, Fmt C does not accept Atr J or JC (see Appendix D).

Offset

The column number where this data field begins in the input record relative to column 1.

Len

The number of columns used to store this data field.

Prec

The number of decimal places to the right of the decimal. (Valid with Fmt B, H, N, or P)

Actions**F2**

(Sort) Rearranges this panel by listing fields in alphabetical order.

F3

(Exit) Returns to Input Descriptions List panel.

F5

(Save) Saves your changes to this panel after you respond YES in the confirmation window (Are you sure? YES or NO).

F6

(Delete) Deletes all the fields in this record from the IRDTAB table and deletes this record's description from the IRDDDESC table.

Browsing Committed Input Records

DataManager provides two panels for viewing committed input records:

- The **Browse Committed IRDs** panel lets you select which record you want to view.
- When you select a committed IRD, DataManager displays its fields on the **Commit Input Record Definitions** panel.

Note: You cannot display the committed IRD Descriptions panel to view fields such as Input ID.

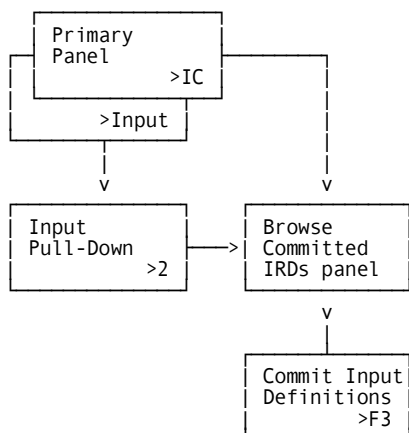

Scrolling

F7 and F8 let you scroll backward and forward through this selection list. You can also use the scroll bar to move through the list.

Actions

Enter

Tab the cursor to the line where an IRD is listed and press Enter to display that record.

Commit Input Record Definitions Panel

This panel lists the fields in the committed IRD you selected from the Browse Committed IRDs panel. Note that committed IRD values cannot be changed on this panel. To add, delete, or update IRDs in this list:

1. Copy all REAL IRDs and one version of committed ORDs (see The COPY Option).
2. Change the DEVELOPMENT version of the Input Record Definitions.
3. Run the Commit job to update the REAL version of IRDs.

Commit Input Record Definitions Panel

```

userid          CA PMA/DataManager          mm/dd/yy hh:mm:ss
__  Input  Output  oPtions  Exit  Help
+-- DMICOME ----- Commit Input Record Definitions -----
|   Panel  Exit  Help
|-----
|   DD Name . . . . : JARS
|   IRD Name . . . . : MBS          More: - + ____   Row: 0001 of 0123
|   Description . . : MVS BATCH STEP
|
|   Field Name      Description          Format Attr Offset  Length  Prec
|-----
|   PAGE_OUT_COUNT          P          00274   07   00
|   PAGE_IN_COUNT          P          00267   07   00
|   STORAGE_INDICATR       C          00266   01   00
|   I/O_INDEX              P          00262   04   00
|   TOTAL_I/O_COUNT        P          00255   07   00
|   OTHER_I/O_COUNT        P          00248   07   00
|
|   F7=Bkwd   F8=Fwd
|-----
Command ==>
F1=Help  F3=Exit  F4=Prompt  F9=Command  F10=Action Bar  F12=Cancel  PA1=Susp

```

Access

The Commit Input Record Definitions panel appears when one of these events occur:

- You type IC in the fast path area of the Primary Panel's action bar, press Enter, tab to one of the records listed on the Browse Committed IRDs panel and press Enter.
- You choose Input on the Primary Panel and **2. Commit Definitions** on the Input pull-down, tab to one of the records listed on the Browse Committed IRDs panel and press Enter.

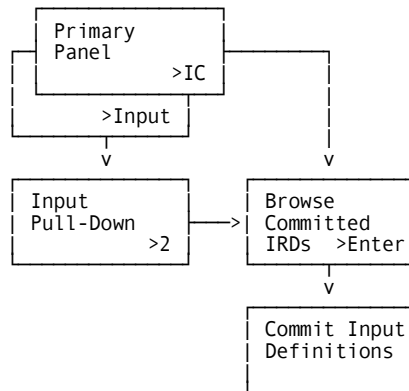

Example 1: Defining Your Own Input Record

DataManager provides many predefined records that your PMA applications can use. However, you may want your PMA application to include other data collected at your site. This example shows how to define the following record for DataManager use.

Using the fast path, you can start building a record by typing II on the Primary Panel and pressing Enter. This displays a blank Input Record Description panel. The first step in defining a new input record is describing the new IRD using this panel.

Field Name	Field Position	Data Format
Jobname	1-8	Character
Start date	9-16	yyyymmdd
Start time	17-22	hhmmss
Stop date	23-30	yyyymmdd
Stop time	31-36	hhmmss
Elapsed time	37-44	sss.sssss
CPU time	45-52	mmm.mmmmm
I/O DBs	53-57	Integer
EXCPS	58-62	Integer

Input Record Description Panel

```

userid                               CA PMA/DataManager                mm/dd/yy hh:mm:ss
---   Input Output oPtions Exit Help
+-- DMIDESP -----Input Record Description -----
|  Panel Exit Help
|  -----
|  | Enter a New Input Record Description or Browse IRDs
|  |
|  | DD Name . . . . . OURDATA
|  | IRD Name . . . . . OURSITE
|  |
|  | > F2=Create  F11=Browse
|  +-----+
Command ==>
F1=Help  F3=Exit  F4=Prompt  F9=Command  F10=Action Bar  F12=Cancel  PA1=Susp
    
```

To describe this new IRD, type over the underscores and fill in values for **DD Name** and **IRD Name**.

- **DD Name** is the internal ddname associated with this data set.
- **IRD Name** is a unique name you assign this type of record.

Then press F2 to create this new input record description. F2 then displays the complete Input Record Description panel.

The values you input on the last panel are displayed in protected fields on the complete Input Record Description panel and the Input Record Definition panel.

Input Record Description Panel (complete)

```

userid                               CA PMA/DataManager                mm/dd/yy hh:mm:ss
---   Input Output oPtions Exit Help
+-- DMIDESD -----Input Record Description -----
|  Panel Exit Help
|  -----
|  | Enter Input Record Description
|  |
|  | DD Name . . . . . OURDATA
|  | IRD Name . . . . . OURSITE
|  |
|  | Description . . . OUR PERFORMANCE DATA
|  | Length of Record . 70
|  | Input ID
|  |   Starting Position _____
|  |   ID Length . . . . . --
|  |   ID Hex Value . . . _____
|  |
|  | F5=Save  F11=Definition
|  +-----+
Command ==>
F1=Help  F3=Exit  F4=Prompt  F9=Command  F10=Action Bar  F12=Cancel  PA1=Susp
    
```

- D**
ddmmyy (European)
- N**
mmmm
- Y**
yymmdd (normalized part)
- S**
s.ss (duration to 1/100 second)
- J**
yyddd (Julian)
- T**
hhmmss
- MC**
mmdyyy
- DC**
ddmmyyyy
- YC**
yyyymmdd (normalized full)
- JC**
yyyddd
- Fmt defines the format of the data.
 - B**
binary
 - H**
hexadecimal numeric
 - C**
character
 - P**
packed
 - N**
character numeric
 - X**
hexadecimal

F

flag byte

- Offset tells what column this field starts in.
- Len tells the number of characters in this field.

If a field has decimal places, specify how many under Prec. The Description field is optional. After you've finished filling in the field's information, press F5 to save that field. DataManager will display a message if it has trouble processing any of your input.

Field Name	Description	Fmt	Atr	Offset	Len	Prec
JOBNAME	JOB NAME	C		1	8	---
STARTDATE	JOB START DATE	N	DC	9	8	---
STARTTIME	JOB START TIME	N	T	17	6	---
STOPDATE	JOB END DATE	N	DC	23	8	---
STOPTIME	JOB END TIME	N	T	31	6	---
ELAPSEDTIME	ELAPSED TIME	N	S	37	8	5

F2=Sort F5=Save F6=Delete F7=Back F8=Fwd

>

Command ==>

F1=Help F3=Exit F4=Prompt F9=Command F10=Action Bar F12=Cancel PA1=Susp

You can wait until you've defined six new fields on the panel before saving.

Caution: You **must save** your entries using F5 before scrolling the panel. If you do not, the data you have entered will be cleared from the panel.

After saving the first six field definitions, you can scroll down and define the rest of the fields in this record.

Field Name	Description	Fmt	Atr	Offset	Len	Prec
CPUTIME	CPU DURATION	N	N	45	8	5
I/O DBS	I/O DBS	N		53	5	---
EXCPS	EXCPS	N		58	5	---
-----	-----	---	---	-----	---	---
-----	-----	---	---	-----	---	---
-----	-----	---	---	-----	---	---

F2=Sort F5=Save F6=Delete F7=Bkwd F8=Fwd

>

Command ==>

F1=Help F3=Exit F4=Prompt F9=Command F10=Action Bar F12=Cancel PA1=Susp

Be sure to press F5 again to save these field definitions, too.

You don't have to add fields in any particular order. However, you can display fields in alphabetic order by pressing F2.

CMD	Field Name	Description	Fmt	Atr	Offset	Len	Prec
-	CPUTIME	CPU DURATION	N	N	45	8	5
-	ELAPSED TIME	ELAPSED TIME	N	S	37	8	5
-	EXCPS	EXCPS	N	-	58	5	---
-	I/O DBS	I/O DBS	N	-	53	5	---
-	JOBNAME	JOB NAME	C	-	1	8	---
-	STARTDATE	JOB START DATE	N	DC	9	8	---

F2=Sort F5=Save F6=Delete F7=Back F8=Fwd

>

Command ==>

F1=Help F3=Exit F4=Prompt F9=Command F10=Action Bar F12=Cancel PA1=Susp

Rule:

Always define input records before output records.

Example 2: Changing a Record's Length or Description

This example shows you how to change information stored in the IRDDESC table. However, DataManager doesn't allow you to change **DD Name** or **IRD Name**.

Begin by typing II in the fast path of the Primary Panel and pressing Enter. Then press F11 to browse the list of existing input records.

Input Descriptions List

```
userid          CA PMA/DataManager          mm/dd/yy hh:mm:ss
  Input  Output  options  Exit  Help
+--- DMIDESL --- Input Descriptions List -----
  Panel  Exit  Help
-----
  Select input description name. Then Enter.

                          More: - + ____  Row 0001 of 0001

      DD Name  IRD      Description      Rec  Hex
      DD Name  Name      Description      Len  Val
-----
  _  OURDATA  OURSITE  OUR PERFORMANCE DATA      70
  -
  -
  -
  -
  Enter  F7=Bkwd  F8=Fwd  F11=Description
+-----+
Command ==>
F1=Help  F3=Exit  F4=Prompt  F9=Command  F10=Action Bar  F12=Cancel  PA1=Susp
```

Then tab to the record whose description needs updating and press F11. In this case, we've selected OURDATA. F11 displays the record you selected on the previous panel.

Input Record Description panel

```
userid          CA PMA/DataManager          mm/dd/yy hh:mm:ss
  Input  Output  oPtions  Exit  Help
+-- DMIDESD -----Input Record Description -----
| Panel Exit Help
|-----
| Enter Input Record Description
|
| DD Name . . . . : OURDATA
| IRD Name . . . . : OURSITE
|
| Description . . . OUR PERFORMANCE DATA
| Length of Record . 70
| Input ID
| Starting Position _____
| ID Length . . . . --
| ID Hex Value . . _____
|
| F5=Save  F11=Definition
+-----
Command ==>
F1=Help  F3=Exit  F4=Prompt  F9=Command  F10=Action Bar  F12=Cancel  PA1=Susp
```

Suppose the actual length of these records is 80, not 70. To make this correction, move the cursor to this field and type 80 over the old value. By typing in new values, you can make changes to all but the first two fields. When you've finished making changes, press F5.

Example 3: Editing Fields in an Existing Input Record

DataManager lets you change any value within a field's definition. Follow these instructions to change field parameters.

Start by selecting the record you want to work on. Using the fast path, you can access these records by typing II and pressing Enter. Press F11 to browse a list of existing input records.

Input Descriptions List

```

userid          CA PMA/DataManager          mm/dd/yy hh:mm:ss
  Input  Output  oPtions  Exit  Help
+--- DMIDESL --- Input Descriptions List -----
| Panel  Exit  Help
|-----
| Select input description name. Then Enter.
|
|                               More: - + ____  Row 0001 of 0001
|
|      IRD
|      DD Name  Name      Description          Rec  Hex
|
|      OURDATA  OURSITE  OUR PERFORMANCE DATA  80
|
|      -
|      -
|      -
|      -
|
|      Enter  F7=Bkwd  F8=Fwd  F11=Description
+-----
Command ==>
F1=Help  F3=Exit  F4=Prompt  F9=Command  F10=Action Bar  F12=Cancel  PA1=Susp

```

Then tab to a specific record and press Enter. This displays the fields within the record you selected on the Input Record Definition panel.

Input Record Definition Panel

```

userid          CA PMA/DataManager          mm/dd/yy hh:mm:ss
  Input  Output  oPtions  Exit  Help
+-- DMIDESE ----- Input Record Definition -----
  Panel  Exit  Help
-----
  DD Name . . . . : OURDATA
  IRD Name . . . . : OURSITE          More: - + ____ Row: 0001 of 0009
  Description . . : OUR PERFORMANCE DATA

  CMD  Field Name      Description          Fmt  Atr  Offset  Len  Prec
  -   -   -   -   -   -   -   -   -   -   -   -   -
  -   JOBNAME          JOB NAME          C    _    00001   8    --
  -   STARTDATE        JOB START DATE    N    DC   00009   8    --
  -   STARTTIME        JOB START TIME    N    T    00017   6    --
  -   STOPDATE         JOB END DATE      N    DC   00023   8    --
  -   STOPTHME         JOB END TIME      N    T    00031   6    --
  -   ELAPSEDTIME      ELAPSED TIME      N    S    00037   8    5

  F2=Sort  F5=Save  F6=Delete  F7=Bkwd  F8=Fwd
-----
Command ==>
  F1=Help  F3=Exit  F4=Prompt  F9=Command  F10=Action Bar  F12=Cancel  PA1=Susp
  
```

Now move your cursor using the arrow keys and make the desired changes. Then press F5 to save your changes before leaving this screen. DataManager responds by displaying the message **Input record has been updated.**

Caution: You **must save** your changes using F5 before scrolling the panel. If you do not, the changes you made will not be saved.

If you try to exit this panel without saving your changes, DataManager prompts you to determine how to handle those changes. A pop-up window gives you the option of canceling any changes you haven't already saved. Select 1 to save your changes. Then you can begin editing another record.

Example 4: Deleting Input That PMA Doesn't Use

This example shows you how to delete individual fields or entire input records (including all fields). Both types of deletions are performed on the same panel. To display this panel, type II in the fast path on the Primary Panel. Then press F11 to browse a list of existing input records. Tab to the record that requires deletion and press Enter.

Input Descriptions List

```
userid          CA PMA/DataManager          mm/dd/yy hh:mm:ss
  Input  Output  options  Exit  Help
+--- DMIDESL --- Input Descriptions List -----
  Panel  Exit  Help
-----
  Select input description name. Then Enter.

                                More: - + ____  Row 0001 of 0001

      DD Name  IRD      Description      Rec  Hex
      DD Name  Name     Description      Len  Val
  _  OURDATA  OURSITE  OUR PERFORMANCE DATA    80
  -
  -
  -
  -
  -
  Enter  F7=Bkwd  F8=Fwd  F11=Description
-----
Command ==>
  F1=Help  F3=Exit  F4=Prompt  F9=Command  F10=Action Bar  F12=Cancel  PA1=Susp
```

This displays the Input Record Definition panel where deletions can happen. This panel currently lists the fields contained in this record. To delete an individual field like **EXCPS**, tab to its row, type a D in the CMD column and press Enter.

Input Record Definition Panel

```

userid          CA PMA/DataManager          mm/dd/yy hh:mm:ss
  Input  Output  oPtions  Exit  Help
+-- DMIDESE ----- Input Record Definition -----
  Panel  Exit  Help
-----
  DD Name . . . . : OURDATA
  IRD Name . . . . : OURSITE          More: - + ____  Row: 0001 of 0005
  Description . . : OUR PERFORMANCE DATA

  CMD  Field Name      Description          Fmt  Atr  Offset  Len  Prec
  --  -
  -   JOBNAME          JOB NAME          C    _   00001   8   --
  -   STARTDATE        JOB START DATE   N    DC  00009   8   --
  D   STARTTIME        JOB START TIME   N    T   00017   6   --
  -   STOPDATE         JOB END DATE     N    DC  00023   8   --
  -   STOPTIME         JOB END TIME     N    T   00031   6   --
  -   ELAPSEDTIME      ELAPSED TIME     N    S   00037   8   5

  F2=Sort  F5=Save  F6=Delete  F7=Bkwd  F8=Fwd
-----
Command ==>
  F1=Help  F3=Exit  F4=Prompt  F9=Command  F10=Action Bar  F12=Cancel  PA1=Susp
  
```

Rule:

You **must** delete ORD fields before deleting the corresponding input fields.

Deleting an **entire** input record and all its fields is even easier: just press F6. Whether or not DataManager prompts you to confirm deletions depends on the value assigned to the Save/Delete Prompt on the User Options panel (see Chapter 4).

Rule:

Always delete output records before input records because DataManager insists that all ORDs have defined IRDs.

Chapter 3: Handling Output Records

DataManager contains panels that maintain the information stored in the ORDESC and ORDTAB tables. These tables describe the output records that DataManager produces. The following panels allow you to maintain output information online:

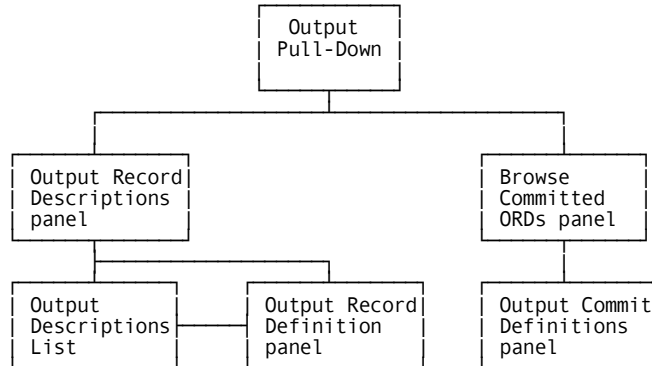

- The **Output pull-down** is the entry panel for accessing these output records. This pull-down lets you access two groups of records:
 - those you can edit (the DEVELOPMENT version)
 - those which have been committed for production use (TEST and PROD versions)
- The **Output Record Descriptions** panel lets you define output of your own or change descriptions of existing records.
- To select a record you want to edit, use the **Output Descriptions List**.
- The **Output Record Definition** panel lets you define new records or edit existing records.

When focusing on committed records, the Output pull-down leads to two panels:

- The **Browse Committed ORDs** panel lists committed records you can select for closer examination.
- The **Output Commit Definitions** panel displays the content of the committed record you selected.

This chapter provides detailed explanations of these panels followed by examples that show how to:

- define your own output record
- change a record's description
- edit fields in an existing output record
- delete output that your PMA applications don't use

Output Pull-Down

This pull-down allows you to access two different groups of records:

- Option 1 accesses the records you can edit (the DEVELOPMENT version).
- Option 2 lets you look at those records you've committed (TEST and PROD versions).

Committed records can't be edited as is. To make changes to committed records, you must first copy them to the DEVELOPMENT version (see The COPY Option).

Output Pull-Down

```

userid          CA PMA/DataManager          mm/dd/yy hh:mm:ss
__  Input  Output  oPtions  Exit  Help

                                     Output
                                     -----
                                     __  1. Output Definitions
                                     __  2. Commit Definitions
                                     -----
                                     | F12=Cancel
                                     -----

Command ==>
F1=Help  F3=Exit  F4=Prompt  F9=Command  F10=Action Bar  F12=Cancel  PA1=Susp

```

Access

The Output pull-down appears when one of these events occurs:

- You type O in the fast path area of the Primary Panel's action bar.
- You choose Output from the Primary Panel's action bar.

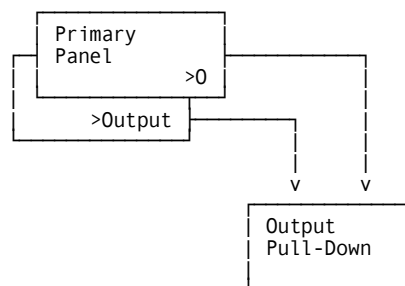

Input

Use one of these methods to select an item from the Output pull-down:

- Tab to an option and press Enter to select that item.
- Type the number of your selection in the input area. For example, type 2 in the input area to select **2. Commit Definitions**.

```
userid          CA PMA/DataManager
__ Input  Output  oPtions  Exit  Help

-----
|          Output
|
| 2  1. Output Definitions
|    2. Commit Definitions
|-----
|
| F12=Cancel
|-----
```

Pathways

1. Output Definitions displays the Output Record Description panel where you can create new or update existing output records.

2. Commit Definitions lists the output records that DataManager has committed.

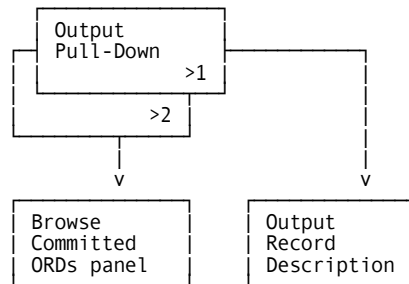

Actions

F12

(Cancel) Removes the Output pull-down and returns to the Primary Panel.

Editing Output Records

This section describes the panels that allow you to edit existing output records and enter new ones. Panels are described in the order you'll see them. Each panel description:

- tells what that panel is used for
- explains how to access that panel
- tells what values to enter into its input fields
- lists the actions this panel can perform
- describes the different exit pathways you can follow

Output Record Description Panel

This panel collects information that DataManager uses to identify the different types of output records it produces. Each type of input record produces at least one output record. These output record descriptions are stored in the ORDESC table.

This panel really serves two purposes: it can define a new output record description, or it can display a list of existing output records.

- Just press F11 to display existing records on the Output Descriptions List.
- To begin defining a new output record, fill in this panel and press F2.

Output Record Description Panel

```
userid          CA PMA/DataManager          mm/dd/yy hh:mm:ss
--            Input Output oPtions Exit Help
+-- DMODESP -----Output Record Description -----
  0 Panel Exit Help
  0 -----
  0 Enter a New Output Record Description or Browse ORDs
  |
  0 ORD Name . . . . . ____
  0 Description . . . . . _____
  0
  0 F2=Create   F11=Browse
+-----
Command ==> _____
F1=Help F3=Exit F4=Prompt F9=Command F10=Action Bar F12=Cancel PA1=Susp
```

Access

The Output Record Description panel appears when one of these events occurs:

- You choose **1. Output Definitions** from the Output pull-down.
- You type OO in the fast path area of the Primary Panel.
- You return from the Output Descriptions List.

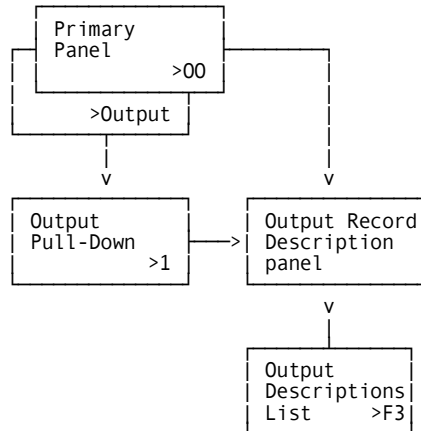

Input

The following fields on the Output Record Description panel are available for input:

ORD Name

A name of up to three characters that you assign to this output record.

Description

A 20-character field describing the output record. (optional)

Actions

F2

(Create) Adds this record to the ORDDDESC table. Then displays this record on the Output Record Definitions panel.

F11

(Browse) Displays the Output Descriptions List.

Output Descriptions List

This panel displays a list of the records in the ORDDDESC table. Each entry describes one type of output record.

Use this panel to:

- scroll through the descriptions list or
- select a particular record for editing

Tab the cursor to the line containing the record you want to select. Then press F3 to edit this record's description or press Enter to edit this record's field definitions.

Output Descriptions List

```

userid          CA PMA/DataManager          mm/dd/yy hh:mm:ss
__  Input  Output  oPtions  Exit  Help

+-- DMODESL -- Output Description List -----+
| Panel  Exit  Help                               |
|-----+-----+                               |
| Select output description name. Then enter.   | wse ORDs | |
| More: - + ____ Row 0001 of 0002              | |       |
| ORD                                           | |       |
| Name  Description          Record            | |       |
|      Length                Length           | |       |
|-----+-----+                               | |       |
|  MBJ  MVS BATCH JOB        00065            | |       |
|  MBP  MVS BATCH PRINT      00063            | |       |
|-----+-----+                               | |       |
|
| Enter  F7=Bkwd  F8=Fwd                       |
+-----+-----+

Command ==> _____
F1=Help  F3=Exit  F4=Prompt  F9=Command  F10=Action Bar  F12=Cancel  PA1=Susp

```

Access

The Output Descriptions List panel appears when one of these events occurs:

- You choose **1. Output Definitions** from the Output pull-down and then press F11.
- You type OO in the fast path area of the Primary Panel, press Enter, and then press F11.
- You return from the Output Record Definitions panel.

Scrolling

F7 and F8 let you scroll backward and forward through the Output Descriptions List. You can also use the scroll bar to move through the list.

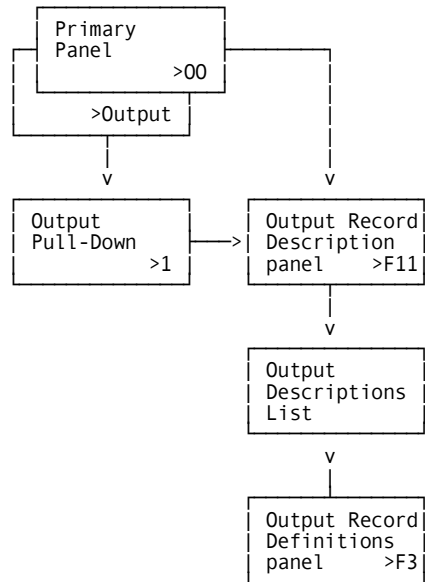

Pathways

Enter

To examine and optionally update a selected record, tab to the line containing this record and press **Enter**. Then DataManager displays this record on the Output Record Definitions panel.

F3

(Exit) Returns to the Output Record Description panel where you can edit the record's description.

Output Record Definition Panel

Edit the Output Record Definitions stored in the ORDTAB table by:

- defining new fields
- changing existing field definitions
- deleting individual fields or the entire output record definition

When building new output records, define each of the fields your PMA applications will use. Output records all require one additional field to prepare them for input to CA PMA Chargeback. That field must be called **CB-CONS** and have Type C. Instead of specifying an IRD Field Name for construct fields, you specify the name of the program DataManager should run to supply values for this field. For CA PMA Chargeback, that program name is CA\$KRCN and it returns values up to 84 characters long.

```

userid          CA PMA/DataManager          mm/dd/yy hh:mm:ss
__  Input  Output  oPtions  Exit  Help
+-- DMODESE ----- Output Record Definition -----
q  Panel  Exit  Help
q -----
q
q  ORD Name . . . : MBJ
q  Description . . : MVS BATCH JOB          More - + ____ Row 0001 of 0001
q  IRD Name . . . : MBJ
q
q  Cmd ORD Field      Type IRD Field Name  Fmt Len Prec  Description
q  _  CB-CONS          C  CA$KRCN          C  84  00  Construct
q  -  -----
q  -  -----
q  -  -----
q  -  -----
q  -  -----
q
q  F5=Save  F6=Delete  F7=Bkwd  F8=Fwd  F11=Header
+-----
Command ==>
F1=Help  F3=Exit  F4=Prompt  F9=Command  F10=Action Bar  F12=Cancel  PA1=Susp
    
```

Access

The Output Record Definitions panel appears when one of these events occurs:

- You type OO in the fast path on the Primary Panel, fill in the Output Record Description panel and press F2.
- You choose Output on the Primary Panel's action bar and select **1. Output Definitions** on the Output pull-down. Then you press F11 to browse existing records, tab to a record and press Enter.

Scrolling

F7 and F8 let you scroll backward and forward through the Output Record Definition list. You can also use the scroll bar to move through the list.

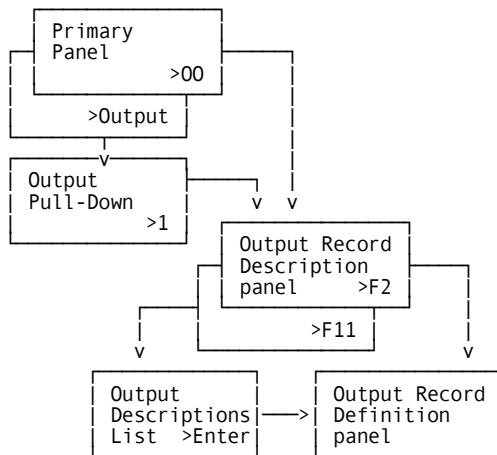

Caution: You **must save** your input using F5 before scrolling the panel. If you do not, the data you have entered will be cleared from the panel.

The first time this panel appears, you are in **insert** mode; no lines appear under the Cmd column, the scroll bar does not reflect a row count, and the only active panel function keys are F5, F7 and F8. When you press F5 (Save), you will receive a message telling you that the insert was successful. At this point, you are in **update** mode. The panel scroll bar provides a row count, the Cmd column is active (lines appear under the column), and **all** panel function keys are active. Pressing F5 (Save) will give you a message telling you that the **update** was successful.

Input

The following fields on the Output Record Definition panel are available for input:

IRD Name

The name given to the input record where these output values can be found. DataManager gets all data values for this output record from just one input record.

Cmd

Delete fields by typing a D in this column and pressing Enter. For redefine fields (Type R), type a U to update the field's offset.

ORD Field

The name you give this field. Together, ORD Name and ORD Field name uniquely identify each output field. When defining CA PMA Chargeback's construct, use the name CB-CONS.

The DataManager COMMIT processing generates CA Earl field definition names based on the field name defined here. If you are using the DataManager COMMIT processing generated field definitions for the ORD data file, or Reconciliation file CA Earl reporting, each field name for a single ORD should be unique within the first 14 positions.

Type

The type of data stored in this field.

C A construct

E A field extracted from an input record.

R A redefine value. For example, redefine MONTH (mm) by breaking down a date in yyyyymmdd format. Specify Type **R** for MONTH and DataManager displays this window to prompt you for the starting position of this redefine field. Specify where this output field begins relative to the input field. For example, the offset for MONTH within yyyyymmdd is 5 (MONTH starts in the date's fifth column). (See Output Record Definition Panel).

```
DMODESF - Redefine
MONTH
defines DATE
with an offset of 5
F5=Save
```

1	2	3	4	5	6	7	8
y	y	y	y	m	m	d	d

IRD Source Field

The name of the input field from which this output field is derived. This input field must occur on the input record specified for **IRD Name**.

When defining the construct for CA PMA Chargeback, specify CA\$KRCN as its IRD Source Field (see sample screen in Output Record Definition Panel).

If you have trouble remembering valid input field names, use the prompt feature. F4 lists all the fields defined for this IRD so you can choose one.

Fmt

The format of this output field:

C Character (use for the CB-CONS construct)

D Date: yyyyymmdd. Always 8 bytes, precision 0, zoned decimal unsigned.

N Numeric: any length, packed decimal

R Duration in seconds. 8 digits, precision=5, packed decimal unsigned.

T Time: hhmmsssttt. (to 1/10,000 of a second) precision 0

Len

The number of columns reserved for this field's data. For the CB-CONS construct, the maximum length is 84.

Prec

The number of decimal places to the right of the decimal. Valid for Fmt R or N.

Description

A description of this output field. (optional)

Actions**F5**

(Save) Saves your changes and additions to this panel.

F6

(Delete) Deletes this entire record.

F11

(Header) Displays existing header information.

U under Cmd

Displays a window containing the redefined field's offset.

Redefine Window

When redefining a value, first create an ORD field (like OUTDATE) for the entire value stored in the IRD field (like STARTDATE).

```

userid          CA PMA/DataManager          mm/dd/yy hh:mm:ss
__  Input  Output  oPtions  Exit  Help

+-- DMODESE ----- Output Record Definition -----
^  Panel  Exit  Help
| -----
|
^  ORD Name . . . : MBJ
^  Description . . : MVS BATCH JOB          More - + ____ Row 0001 of 0001
^  IRD Name . . . : MBJ
^
^  Cmd ORD Field   Type  IRD Field Name  Fmt Len Prec  Description
^
^  _  OUTDATE      E    STARTDATE       N  8   00  Save the entire date
^  _  _____   -    _____      -   -   -   _____
  
```

Then save this field definition before proceeding. To save, just press F5.

Then you can redefine STARTDATE by creating a new field that stores just part of the original value. For example, you would define STARTMONTH this way.

```

userid          CA PMA/DataManager          mm/dd/yy hh:mm:ss
__  Input  Output  oPtions  Exit  Help

+-- DMODESE ----- Output Record Definition -----
^  Panel  Exit  Help
| -----
|
^  ORD Name . . . : MBJ
^  Description . . : MVS BATCH JOB          More - + ____ Row 0001 of 0001
^  IRD Name . . . : MBJ
^
^  Cmd ORD Field   Type  IRD Field Name  Fmt Len Prec  Description
^
^  _  OUTDATE      E    STARTDATE       N  8   00  Save the entire date
^  _  STARTMONTH___ R    OUTDATE_______ N  2   00  Just the month value
  
```

DataManager needs to know which two characters in OUTDATE store the value for STARTMONTH. DataManager prompts you for this information using the Redefine window which appears when you press Enter.

```

userid          CA PMA/DataManager          mm/dd/yy hh:mm:ss
__  Input  Output  oPtions  Exit  Help

+-- DMODESE ----- Output Record Definition -----
| Panel  Exit  Help
| -----+----- DMODESF - Redefine -----+-----
|
| ORD Name . . . : MBJ          STARTMONTH
| Description . . : MVS BATCH| redefines OUTDATE          |001 of 0001
| IRD Name . . . : MBS          with an offset of 5
|
| Cmd ORD Field  Type  IRD F| F5=Save          |option
|
| OUTDATE          E  STARTDATE          N 8  00 Save the entire date
| STARTMONTH      R  OUTDATE              N 2  00 Just the month value
  
```

If OUTDATE has the form yyyymmdd, STARTMONTH has an offset of 5.

If you ever want to change the offset value for a redefine field, just type U in the CMD column on that line. DataManager then displays the Redefine window again so you can change the offset value. Be sure to press F5 to save your input before leaving the Redefine window.

Updating the offset value

```

userid          CA PMA/DataManager          mm/dd/yy hh:mm:ss
__  Input  Output  oPtions  Exit  Help

+-- DMODESE ----- Output Record Definition -----
| Panel  Exit  Help
| -----+----- DMODESF - Redefine -----+-----
|
| ORD Name . . . : MBJ          STARTMONTH
| Description . . : MVS BATCH| redefines OUTDATE          |001 of 0001
| IRD Name . . . : MBS          with an offset of 5
|
| Cmd ORD Field  Type  IRD F| F5=Save          |option
|
| OUTDATE          E  STARTDATE          N 8  00 Save the entire date
| U STARTMONTH      R  OUTDATE              N 2  00 Just the month value
|
|>
|
|-----|-----|-----|-----|
|-----|-----|-----|-----|
|-----|-----|-----|-----|
|-----|-----|-----|-----|
|
| F5=Save  F6=Delete  F7=Bkwd  F8=Fwd  F11=Header
+-----+-----+-----+-----+
Command ==>
F1=Help  F3=Exit  F4=Prompt  F9=Command  F10=Action Bar  F12=Cancel  PA1=Susp
  
```

Output Record Header

DataManager uses the output record header to standardize the format of a crucial part of every PMA output record.

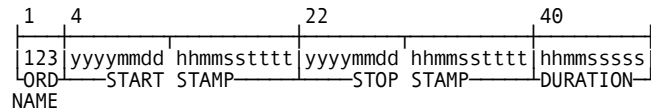

This is where DataManager stores the date, time and duration of services. Not all fields are required. Just fill in one of these combinations on the Output Record Header panel:

- Start Stamp and Stop Stamp
- Start Stamp and Duration
- Stop Stamp and Duration
- Start Stamp, Stop Stamp and Duration

Obviously, DataManager expects you to specify fields that are currently defined dates, times or durations. Then DataManager merges these IRD fields into start and stop stamps.

If you also want these same IRD fields to be unique fields in the output data records, you must use them to define ORD fields on the Output Record Definition panel.

Output Record Header

```

userid          CA PMA/DataManager          mm/dd/yy hh:mm:ss
__  Input  Output  oPtions  Exit  Help

+- DMODESH ----- Output Record Header -----+
| Panel  Exit  Help                               |
|-----|-----|
| Enter the Output Record Header Information      |
| |                                               |
| ORD Name  : MJB                               | 0000 of: 0000
| IRD Name  : MJB                               |
| |                                               |
|          IRD Date          IRD Time          | ription
|          Field            Field            |
| |                                               |
| Start Stamp . _____                     |
| Stop Stamp  . _____                     |
| |                                               |
| Duration Time . . . . . _____           |
| |                                               |
| F5=Save                                         |
+-----+
+-----+
Command ==> _____
F1=Help  F3=Exit  F4=Prompt  F9=Command  F10=Action Bar  F12=Cancel  PA1=Susp

```

ORD Name and IRD Name are protected fields (values preceded by :) whose values are derived from the Output Record Definition panel.

Access

The Output Record Header panel appears when one of these events occurs:

- You type OO in the fast path area of the Primary Panel's action bar, fill in the Output Record Description panel, press F2, fill in the Input Record Definition panel and press F5.
- You choose Output on the Primary Panel's action bar and select **1. Output Definitions** on the Output pull-down. Then you press F11 to browse existing records, tab to a record, press Enter and then press F11.

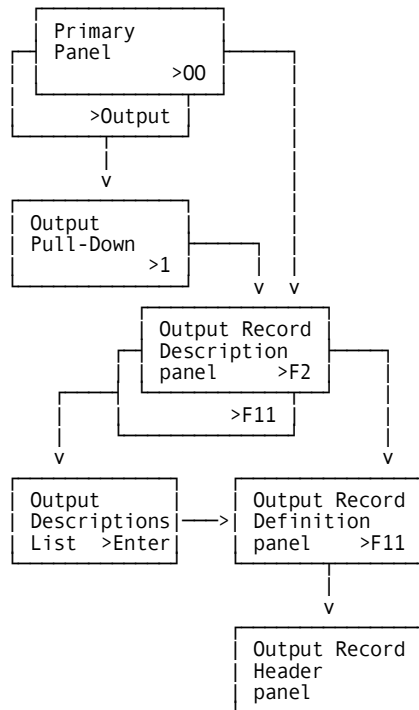

Input

The following fields on the Output Record Header panel are available for input:

IRD Date Field

The names of IRD date fields. These values specify the dates when this service started and ended.

IRD Time Field

The names of IRD time fields. These values specify the times when this service started and ended.

Duration Time

The name of the IRD field that stores the duration of these services.

Actions

F5

(Save) Saves this output header information.

Browsing Committed Output Records

DataManager provides two panels for viewing committed output records:

- The **Browse Committed ORDs** panel lets you select which record you want to view.
- When you select a committed ORD, DataManager displays its fields on the **Output Commit Definition** panel.

Browse Committed ORDs Panel

This panel lists the names and descriptions of those Output Record Definitions that have already been committed in the TEST or PROD versions of the database. Once records have been committed, all you can do is look at them.

- To examine one of these ORDs, tab to that line and press Enter.
- To display the other version of committed output definitions, type TEST or PROD after Version and press Enter.
- To add, delete, or update ORDs in this list:
 - Copy all REAL IRDs and committed TEST or PROD ORDs (see The COPY Option).
 - Change the DEVELOPMENT version of the Output Description List.
 - Run the Commit job to update the PROD or TEST ORDs.

Browse Committed ORDs Panel

```

userid          CA PMA/DataManager          mm/dd/yy hh:mm:ss
__  Input  Output  oPtions  Exit  Help
+ DMOCOMP ----- Browse Committed ORDs -----
|  Panel  Exit  Help
|-----
|
|  Version . . . . . PROD
|
|          More - +          Row 0001  of 0001
|
|          ORD      Description          Length
|  -      MBS      MVS JARS BATCH STEP    00796
|  -
|  -
|  -
|  -
|  -
|
|  Enter  F7=Bkwd  F8=Fwd   F11=Browse
|-----
|  Command ==>
|-----
F1=Help  F3=Exit  F4=Prompt  F9=Command  F10=Action Bar  F12=Cancel  PA1=Susp
    
```

Access

The Browse Committed ORDs panel appears when one of these events occurs:

- You type OC in the fast path area of the action bar.
- You choose Output on the Primary Panel and **2. Commit Definitions** on the Output pull-down.
- You return from the Output Commit Definition panel.

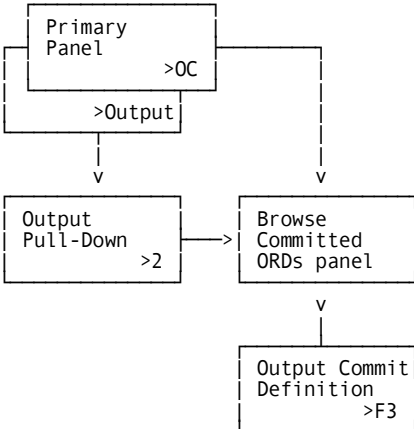

Scrolling

F7 and F8 let you scroll backward and forward through this selection list. You can also use the scroll bar to move through the list.

Input

The following field on the Browse Committed ORDs panel is available for input:

Version

DataManager supports two environments: production and test. Those definitions that your site uses daily are in the PROD database. The TEST database gives you another environment where you can experiment and perfect new output records. Type PROD or TEST here to tell DataManager which output records to list.

Actions

Enter

Select: tab the cursor to the line where an ORD is listed and press Enter to display that record.

Output Commit Definition Panel

This panel lists the data fields in the committed ORD you selected from the Browse Committed ORDs panel. Note that committed ORD definitions cannot be changed on this panel. To add, delete, or update ORDs in this list:

- Copy all REAL IRDs and committed TEST or PROD ORDs (see The COPY Option).
- Change the DEVELOPMENT version of the Output Record Descriptions.
- Run the Commit job to update the PROD or TEST ORDs.

Output Commit Definition Panel

```

userid          CA PMA/DataManager          mm/dd/yy hh:mm:ss
__   Input  Output  oPtions  Exit  Help

+-- DMOCOME ----- Output Commit Definition -----
  0  Panel  Exit  Help
  0  -----
  0
  0  ORD Name . . . . MBS
  0  Description . . . MVS JARS BATCH STEP_ More - + ____ Row 0001 of 0129
  0  IRD Name . . . . MBS
  0
  0  Field Name      Type IRD Field Name  Fmt Len Prec  Description
  0
  0  RDR START TIME  E  RDR START TIME  T  10  04
  0  RDR START DATE  E  RDR START DATE  D  08  00
  0  VERSION          E  VERSION          N  01  00
  0  FILE ID         E  FILE ID         C  01  00
  0  CPU ID          E  CPU ID          C  01  00
  0  STOP HHMM       R  STOPSTAMP       C   4   0  STOP TIME (HHMM)
  0
  0  F7=Bkwd  F8=Fwd
+-----
Command ==> _____
F1=Help  F3=Exit  F4=Prompt  F9=Command  F10=Action Bar  F12=Cancel  PA1=Susp

```

Access

The Output Commit Definition panel appears when one of these events occur:

- You type OC in the fast path area of the Primary Panel's action bar, tab to one of the records listed on the Browse Committed ORDs panel and press Enter.
- You choose Output on the Primary Panel and **2. Commit Definitions** on the Output pull-down, tab to one of the records listed on the Browse Committed ORDs panel and press Enter.

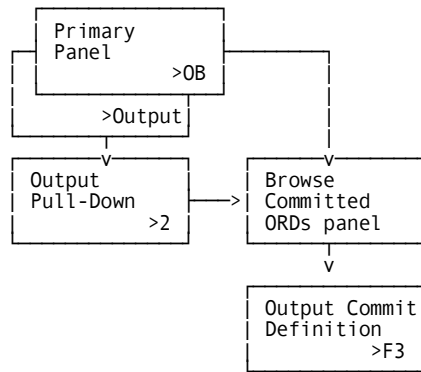

Scrolling

F7 and F8 let you scroll backward and forward through this field list. You can also use the scroll bar to move through the list.

Example 1: Defining Your Own Output Record

DataManager provides many predefined records that your PMA applications can use. However, you may want your PMA application to include other data collected at your site. This example shows how to handle the following input for DataManager use.

Field Name	Description	Fmt	Atr	Offset	Len	Prec
JOBNAME	JOB NAME	C		1	8	
STARTDATE	JOB START DATE	N	DN	9	8	
STARTTIME	JOB START TIME	N	T	17	6	
STOPDATE	JOB END DATE	N	DN	27	8	
STOPTIME	JOB END TIME	N	T	35	6	
ELAPSEDTIME	ELAPSED TIME	N	TD	45	8	
CPUTIME	CPU DURATION	N	TD	53	6	
I/O DBS	I/O DBS	N		61	5	
EXCPS	EXCPS	N		66	5	

Using the fast path, you can start building an output record by typing OO on the Primary Panel and pressing Enter. That displays a blank Output Record Description panel. The first step to follow when defining a new output record is describing the new ORD on this panel.

```

userid          CA PMA/DataManager          mm/dd/yy hh:mm:ss
__   Input  Output  oPtions  Exit  Help

+-- DMODESP -----Output Record Description -----
  0 Panel  Exit  Help
  0 -----
  0 Enter a New Output Record Description or Browse ORDs
  |
  0 ORD Name . . . . . OUR
  0 Description . . . . . OUR PERFORMANCE DATA
  0
  0 F2=Create   F11=Browse
+-----
  
```

To describe this new ORD, type in a unique value for **ORD Name**. Description is optional and Record Length is computed by DataManager.

Then press F2 to save this description and proceed with defining the fields in this ORD on the Output Record Definition panel.

Output Record Definition Panel

```

userid          CA PMA/DataManager          mm/dd/yy hh:mm:ss
__   Input  Output  oPtions  Exit  Help

+-- DMODESE ----- Output Record Definition -----
  0 Panel  Exit  Help
  0 -----
  0
  0 ORD Name . . . : OUR
  0 Description . . : OUR PERFORMANCE DATA More - + ____ Row ____ of 0001
  0 IRD Name . . . .
  0 >
  0
  0 Cmd ORD Field      Type IRD Field Name  Fmt Len Prec  Description
  0 -----
  0 -----
  0 -----
  0 -----
  0 -----
  0 -----
  0 -----
  0
  0 F5=Save  F6=Delete  F7=Bkwd  F8=Fwd  F11=Header
+-----
Command ==>
F1=Help  F3=Exit  F4=Prompt  F9=Command  F10=Action Bar  F12=Cancel  PA1=Susp
  
```

Begin by specifying what IRD is the source for these fields. If you can't remember a specific IRD name, use the prompt feature to view a list of valid IRDs. You must specify an existing IRD here. This is why you must define IRDs before ORDs.

Rule:

Always define input records before output records.

To define each **field**, just type over the underlining and fill in **ORD Field, Type, IRD Field Name, Fmt** and **Len** values:

- No two ORD fields within a record can have the same name.
- The **Type** of data stored in this field:
 - C**
A construct.
 - E**
A data field extracted from an input record.
 - R**
A redefined value. For example, mmddy broken down into mm, dd, yy.
- **IRD Field Name** is the name of the input field from which this output field is derived. This input field must occur on the input record specified for **IRD Name**.
- **Fmt** is the format of this output field:
 - C**
Character
 - D**
Date: yyyyymmdd. Always 8 bytes, precision 0, zoned decimal unsigned.
 - N**
Numeric: any length, packed decimal
 - R**
Duration in seconds. 8 digits, precision=5, packed decimal unsigned.
 - T**
Time: hhmmsssttt. (to 1/10,000 of a second) precision 4
- **Len** tells the number of characters in this field.

Note: The length and precision of formats **D**, **R**, and **T** are fixed as described on the previous page and **cannot** be changed.

```

  ? Cmd ORD Field      Type IRD Field Name  Fmt Len Prec  Description
  ?
  ? _ JOBNAME          E  JOBNAME          C  8_  _
  ? _ CPUTIME          E  CPUTIME          R  6_  _
  ? _ I/O DBS          E  I/O DBS          N  5_  _
  ? _ EXCPS            E  EXCPS            N  5_  _
  ? _ CB-CONS          C  CA$KRCN          C 84  _
  ?
  ? >
  ?
  ? _
  ?
  ? F5=Save  F6=Delete  F7=Bkwd  F8=Fwd  F11=Header
+-----+
Command ==>
F1=Help  F3=Exit  F4=Prompt  F9=Command  F10=Action Bar  F12=Cancel  PA1=Susp

```

Be sure to remember to save the construct field by pressing F5. Then press F11 to define the Output Record Header by filling in IRD field names.

Output Record Header Panel

```

userid                CA PMA/DataManager                mm/dd/yy hh:mm:ss
__   Input  Output  oPtions  Exit  Help

+- DMODESH ----- Output Record Header -----
?  Panel  Exit  Help
? -----
?  Enter the Output Record Header Information
|
?  ORD Name  : OUR                0000 of: 0000
?  IRD Name  : OURSITE
?
?                IRD Date          IRD Time          ription
?                Field            Field
?
?  Start Stamp . STARTDATE_____ STARTTIME_____
?  Stop Stamp  . STOPDATE_____  STOPTIME_____
?
?  Duration Time . . . . . ELAPSEDTIME_____
|
?  F5=Save
+-----+
+-----+
Command ==>
F1=Help  F3=Exit  F4=Prompt  F9=Command  F10=Action Bar  F12=Cancel  PA1=Susp

```

Then press F5 to save this information.

Rule:

Always remember to define an output record header.

Example 2: Changing an Output Record's Description

This example shows you how to change the description stored in the ORDESC table.

Begin by typing OO in the fast path of the Primary Panel and pressing Enter. Then press F11 to browse the list of existing output records.

Output Descriptions List

```
userid          CA PMA/DataManager          mm/dd/yy hh:mm:ss
__  Input  Output  oPtions  Exit  Help
+-- DMODESL -- Output Description List -----
| Panel  Exit  Help
|-----
| Select output description name. Then enter.  wse ORDs
|
| More: - + ____  Row 0001 of 0002
|
| ORD  Description          Length
| -   MBJ  MVS BATCH JOB      00065  -----
| -   MBP  MVS BATCH PRINT     00063
| > -   OUR  OUR PERFORMANCE DATA  00030
| -
| -
| Enter  F7=Bkwd  F8=Fwd
+-----+
Command ==>
F1=Help  F3=Exit  F4=Prompt  F9=Command  F10=Action Bar  F12=Cancel  PA1=Susp
```

To choose which description appears, tab to the record of your choice and press Enter. In this case, we've selected OUR record. The Enter key will display the record you selected on the following panel.

Output Record Definition Panel

```

userid          CA PMA/DataManager          mm/dd/yy hh:mm:ss
__   Input  Output  oPtions  Exit  Help

+-- DMODESE -----Output Record Definition -----
  0 Panel  Exit  Help
  0 -----
  0 ORD Name . . . OUR
  0 Description . . . OUR PERFORMANCE DATA More - + ____ Row ____ of ____
  0 -----
  0 Cmd  ORD Field  Type  IRD Field Name  Fmt  Len  Prec  Description
  0 ---  -----  ---  -----  ---  ---  ---  -----
  0 ---  -----  ---  -----  ---  ---  ---  -----
  0 ---  -----  ---  -----  ---  ---  ---  -----
  0 ---  -----  ---  -----  ---  ---  ---  -----
  0 F5=Save  F6=Delete  F7=Bkwd  F8=Fwd  F11=Header
+-----
Command ==>
F1=Help  F3=Exit  F4=Prompt  F9=Command  F10=Action Bar  F12=Cancel  PA1=Susp

```

Move the cursor to the Description field and type in a new description. Press F5 to save your changes.

Are you sure Pop-up window

```

userid          CA PMA/DataManager          mm/dd/yy hh:mm:ss
__   Input  Output  oPtions  Exit  Help

+-- DMODESE -----Output Record Definition -----
  0 Panel  Exit  Help
  0 -----
  0 ORD Name .....OUR
  0> Description ...NEW PERFORMANCE DATA More - + ____ Row ____ of ____
  0 IRD Name .....OUR
  0 -----
  0 Cmd  ORD Field  Type  | Are you sure ? | Len  Prec  Description
  0 ---  -----  ---  | YES    NO      | ---  ---  -----
  0 ---  -----  ---  |-----+-----| ---  ---  -----
  0 ---  -----  ---  |-----+-----| ---  ---  -----
  0 ---  -----  ---  |-----+-----| ---  ---  -----
  0 F5=Save  F6=Delete  F7=Bkwd  F8=Fwd  F11=Header
+-----
Command ==>
F1=Help  F3=Exit  F4=Prompt  F9=Command  F10=Action Bar  F12=Cancel  PA1=Susp

```

Select option YES and press Enter to save changes.

Example 3: Editing Fields in an Existing Output Record

DataManager lets you change any value within a field's definition. Follow these instructions to change field parameters.

Start by selecting the record you want to work on. Using the fast path, you can access these records by typing OO and pressing Enter. Press F11 to browse a list of existing output records. **Output Descriptions List**

```
userid          CA PMA/DataManager          mm/dd/yy hh:mm:ss
__  Input  Output  oPtions  Exit  Help

+-- DMODESL -- Output Description List -----
| Panel  Exit  Help
|-----
| Select output description name. Then enter.   wse ORDs
|
| More: - + ____ Row 0001 of 0003
|
| ORD      Description          Record
| Name     Description          Length
|-----
| -   MBJ   MVS BATCH JOB       00065
| -   MBP   MVS BATCH PRINT     00063
| -   OUR   OUR PERFORMANCE DATA 00070
|
|
| Enter  F7=Bkwd  F8=Fwd
+-----

Command ==>
F1=Help  F3=Exit  F4=Prompt  F9=Command  F10=Action Bar  F12=Cancel  PA1=Susp
```

Then tab to a specific record and press Enter. That displays the fields within the record you selected on the Output Record Definition panel.

Output Record Definition Panel

```

userid          CA PMA/DataManager          mm/dd/yy hh:mm:ss
__   Input  Output  oPtions  Exit  Help

+-- DMODESE ----- Output Record Definition -----
| Panel  Exit  Help
|
|
| ORD Name . . . . : OUR
| Description . . . : OUR PERFORMANCE DATA More - + ____ Row 0001 of 0005
| IRD Name . . . . : OURSITE
|
| Cmd ORD Field      Type IRD Field Name  Fmt Len Prec  Description
|
|  _ JOBNAME_____  E  JOBNAME_____  C  8_  _  _____
|  _ CPUTIME_____  E  CPUTIME_____  R  6_  _  _____
|  _ I/O DBS_____  E  I/O DBS_____  N  5_  _  _____
|  _ EXCPS_____   E  EXCPS_____   N  5_  _  _____
|  _ CB-CONS_____  C  CA$KRCN_____  C  84  _  _____
|
|
| F5=Save  F6=Delete  F7=Bkwd  F8=Fwd  F11=Header
+-----+
Command ==> _____
F1=Help  F3=Exit  F4=Prompt  F9=Command  F10=Action Bar  F12=Cancel  PA1=Susp

```

Now move your cursor using the arrow keys and make the desired changes. Then press F5 to save those changes before leaving this screen. DataManager responds by displaying the message **Output record has been updated.**

Caution: You **must save** your entries using F5 before scrolling the panel. If you do not, the data you have entered will be cleared from the panel.

If you try to exit this panel without saving your changes, DataManager prompts you to determine how to handle those changes. A pop-up panel gives you the option of cancelling any changes you haven't already saved. Select 1 to save your changes. Then you can begin editing another record.

Example 4: Deleting Output That PMA Doesn't Use

This example shows you how to delete fields as well as output records. Both types of deletions are performed on the same panel. To get there, type OO in the fast path on the Primary Panel. Then press F11 to browse a list of existing output records. Tab to the record that requires deletion and press Enter.

Output Descriptions List

```

userid          CA PMA/DataManager          mm/dd/yy hh:mm:ss
__  Input  Output  oPtions  Exit  Help

+-- DMODESL -- Output Description List -----
| Panel  Exit  Help
| -----
| Select output description name. Then enter.  wse ORDs
|
| More: - + ____  Row 0001 of 0002
|
| ORD          Record
| Name  Description          Length
|-----
| -   MBJ  MVS BATCH JOB          00065
| -   MBP  MVS BATCH PRINT        00063
| -   OUR  OUR PERFORMANCE DATA  00070
|
|
| Enter  F7=Bkwd  F8=Fwd
+-----

Command ==>
F1=Help  F3=Exit  F4=Prompt  F9=Command  F10=Action Bar  F12=Cancel  PA1=Susp

```

That displays the Output Record Definition panel where deletions can happen. That panel currently lists the fields contained in this record. To delete an individual field like **EXCPS**, tab to that line, type a D in the Cmd column and press Enter.

Output Record Definition Panel

```

userid          CA PMA/DataManager          mm/dd/yy hh:mm:ss
__  Input  Output  oPtions  Exit  Help

+-- DMODESE ----- Output Record Definition -----
| Panel  Exit  Help
|
|
| ORD Name . . . . : OUR
| Description . . . : OUR PERFORMANCE DATA More - + ___ Row ___ of 0001
| IRD Name . . . . : OURSITE
|
| Cmd ORD Field      Type IRD Field Name  Fmt Len Prec  Description
|
| _  JOBNAME         E  JOBNAME         C  8_  _  _____
| _  CPUTIME         E  CPUTIME         R  6_  _  _____
| _  I/O DBS         E  I/O DBS         N  5_  _  _____
| D  EXCPS           E  EXCPS           N  5_  _  _____
| _  CB-CONS         C  CA$KRCN         C 84  _  _____
|
|
| F5=Save  F6=Delete  F7=Bkwd  F8=Fwd  F11=Header
+-----+
Command ==> _____
F1=Help  F3=Exit  F4=Prompt  F9=Command  F10=Action Bar  F12=Cancel  PA1=Susp

```

Rule:

You **must** delete ORD fields before deleting the corresponding input fields.

Deleting an **entire** output record and all its fields is even easier: just press F6. Whether or not DataManager prompts you to confirm deletions depends on the value assigned to the Save/Delete Prompt on the User Options panel (see Chapter 4).

Rule:

Always delete output records before input records because DataManager insists that all ORDs have defined IRDs.

Chapter 4: Options

Choosing options from the Primary Panel's action bar displays the User Options panel. This panel gives individual users the ability to change the default settings for the options listed. Each user's settings are stored in the OPTTAB table and changes impact all future sessions.

User Options Panel

```

userid          CA PMA/DataManager          mm/dd/yy hh:mm:ss
--  Input Output oPtions Exit Help
+-- DMOPTNS ----- User Options -----+
|   Panel  Exit  Help
|-----+
| Update options. Then Save.
| Warning Msgs . . . . ___ Mnemonics . . . . ___
| Info Msgs   . . . . ___ Action Bar . . . . ___
| Save/Delete Prompt . ___ Database Depth . . 500
| PF13-24 = PF1-12 . . ___
|
| F5=Save
+-----+
Command ==>
F1=Help F3=Exit F4=Prompt F9=Command F10=Action Bar F12=Cancel PA1=Susp
  
```

Access

The User Options panel appears when one of these events occurs:

- You type P in the fast path area of the Primary Panel's action bar.
- You choose options from the Primary Panel's action bar.

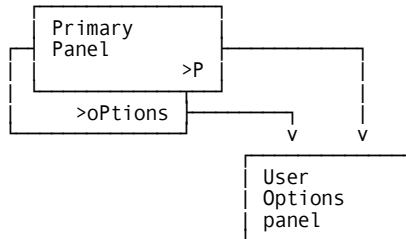

Input

The User Options panel contains the following input fields. Note that these options' defaults are specified in the OPTTAB table. However, you can use this panel to change them from now on.

Warning Msgs

Specifies whether or not you want *warning* messages displayed.
Default: YES

Mnemonics

Allows you to remove fast path entry fields by specifying Mnemonics. . . NO. NO removes all underscore characters in fast paths. Then all selections from the Primary Panel and pull-downs are made by tabbing the cursor to the appropriate selection and pressing Enter. Default: YES

```
userid          CA PMA/DataManager          mm/dd/yy hh:mm:ss
  Input  Output  oPtions  Exit  Help
-----
          Input
          1. Input Definitions
          2. Commit Definitions
-----
          F12=Cancel
```

Info Msgs

Specifies whether or not you want *informational* messages displayed.
Default: YES

Action Bar

Indicates whether or not you want the action bar displayed in reverse video (REV). Default: NOREV

Save/Delete Prompt

Indicates whether or not you want the Save and Delete prompts displayed. Default: BOTH Options include:

SAVE Only the SAVE prompt will be displayed.

DEL Only the DElete prompt will be displayed.

BOTH Both the SAVE and DElete prompts will be displayed.

OFF Suppresses save and delete prompts.

Database Depth

Defines the maximum number of records returned for a database access. A minimum of 10 rows is required. Default: 500

PF13-24 = PF1-12

Allows you to make function keys 13-24 work the same way PF1-12 do.
Default: YES

Actions

F5

(Save) Saves these options in the OPTTAB table. The new values are effective immediately and apply to future sessions as well as the current session.

Chapter 5: Using Help

All CA PMA applications provide you with an extensive Help facility that is available to you from the moment you log on to an application. This chapter:

- explains how to request help
- describes the About window
- summarizes what these help panels have in common
- describes the different types of help that are available
- tells you how to leave Help

Requesting Help

You can request Help in the following ways:

To get this:	Do this:
Panel Help	Press F1 when a panel appears; make sure the cursor is not positioned on a field.
Field Help	Tab the cursor to the field you want specific information for and press F1.
Help pull-down	Select the Help option from an action bar.

To request Help from an action bar, tab the cursor to the **Help** keyword and press Enter. The following Help pull-down appears:

```
userid          CA PMA/DataManager          mm/dd/yy hh:mm:ss
_  Input  Output  oPtions  Exit  Help

A 1-character field that allows
you to make a selection using a
mnemonic that can be either a
number or the first letter of an
action.

You can also make your selection
by tabbing the cursor to the
action you want to perform and
pressing Enter.

Help
- 1. Index
  2. Table of Contents
  3. Help for Help
  4. About
-----
F12=Cancel

Command ==> _____
F1=Help  F3=Exit  F4=Prompt  F9=Command  F10=Action Bar  F12=Cancel  PA1=Susp
```

An overview of Help pull-down choices is provided below.

1. Index

Displays a list of items, in alphabetical order, for which Help is available.

2. Table of Contents

Displays a list of topics for which Help is available.

3. Help for Help

Gives you information on how to use the Help system.

4. About

Displays a pop-up window telling you the *genlevel* of the CA PMA product you are using.

The About Window

To verify the *genlevel* of the CA PMA product you are using, you must select the Help keyword from an action bar and then select **About**. A pop-up window appears, telling you the genlevel of your product.

Access

The About window appears when you choose Help from the Primary Panel's action bar. Then select **4. About** from the Help pull-down.

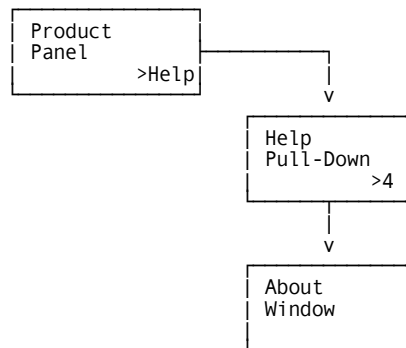

Action

F3

(Exit) Returns you to the last product panel that DataManager displayed.

Help Panel Areas

Overview

The following sample panel is the Help panel for the Input pull-down. The top line of the panel provides you with the following information:

panelid:

Displays the Help panelid. The panelid closely resembles the product panelid and always ends with the letter H.

panel name:

Tells you either the topic or the panel that is being discussed.

HELP:

Identifies the panel as a Help panel.

The bottom line tells you the function key settings that are valid for the panel. A description of these settings is provided in Help Function Key Settings.

```

userid          CA PMA/DataManager          mm/dd/yy hh:mm:ss
+__ DMINPUTH _ _____ INPUT PULL-DOWN _____ HELP
0
0 The Input pull-down offers you two options:          0
0               Input Definitions - for editing input records 0
0               Commit Definitions - for browsing committed input records 0
0
0 To choose an option, use one of these methods:        0
0
0 * Type the number of your selection at the current cursor location. 0
0
0 * Tab to your selection and press Enter.              0
0
0 For further information, tab to an item below and press Enter.      0
0               __ Input Definitions                      0
0               __ Commit Definitions                    0
0
0 F1=Help F2=Topic F3=End F5=Cont F7=Prev F8=Next F9=Index 0
+-----+

```

Help Function Key Settings

Function key settings let you move efficiently through CA PMA Help facilities. Function key assignments may vary from panel to panel (indicated by Fn).

```
  0
  0 F1=Help F2=Topic F3=End F5=Cont F7=Prev F8=Next F9=Index  0
  +-----+-----+-----+-----+-----+-----+-----+-----+
```

F1=Help

Displays an explanation of how to use the Help facility.

F2=Topic

Displays the Help Table of Contents.

F3=End

Returns you to the resident product panel from which you called Help.

F5=Cont

Takes you to the next panel (field help takes you to the index; topic help takes you to the table of contents).

F7=Prev

Takes you to the previously viewed panel.

F8=Next

Takes you to the next *topic* discussed.

F9=Index

Displays the Help Index.

Moving Through Help

The following diagram gives you an overview of how you can access and move through the CA PMA Help facility, when you request Help from a product panel.

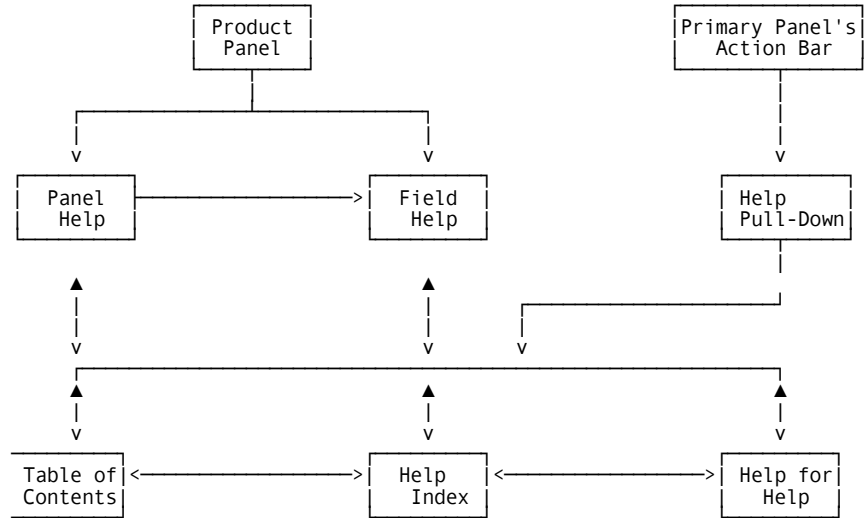

Exiting Help

To exit the CA PMA Help facility, simply press F3.

Help Panels

Panel Helps

Panel Help is available for every product panel. These Help panels also list fields from the product panel for which there is Help.

```

userid          CA PMA/DataManager          mm/dd/yy hh:mm:ss
+-- DMODESEH _ ----- OUTPUT RECORD DEFINITION ----- HELP -----+
|
|  The Output Record Definition panel focuses on the fields that make up
|  a record.  It lets you:
|
|  * define new fields
|  * change existing field definitions
|  * delete individual fields or the entire record
|
|  Use the Output Descriptions List to select the record whose definition
|  appears on this panel.
|
|  For information about a field, tab to it below and press Enter.
|
|  __ ORD Name   __ Description  __ Scroll bar  __ IRD Name
|  __ CMD        __ ORD Field    __ Type         __ IRD Field Name
|  __ Fmt        __ Len          __ Prec         __ Description
|  __ SAVE       __ DELETE       __ BKWD         __ FWD
|  __ HEADER
|
|  F1=Help  F2=Topic  F3=End  F5=Cont  F7=Prev  F8=Next  F9=Index
+-----+

```

Access

Panel Helps appear when you press F1 and the cursor is not positioned on a field.

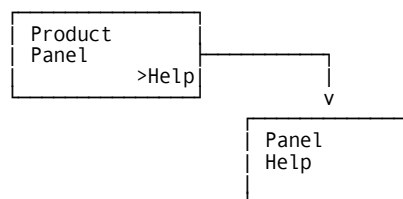

Actions

F1

(Help) Displays an explanation on how to use the Help facility.

F2

(Topic) Displays the Help Table of Contents.

F3

(End) Returns you to the resident product panel from which you called Help.

F5

(Cont) Takes you to the next logical panel.

F7

(Prev) Takes you to the previously viewed panel.

F8

(Next) Takes you to the next topic discussed.

F9

(Index) Displays the Help Index.

Actions

F1

(Help) Displays an explanation on how to use the Help facility.

F2

(Topic) Displays the Help Table of Contents.

F3

(End) Returns you to the resident product panel from which you called Help.

F5

(Cont) Takes you to the next logical panel.

F7

(Prev) Takes you to the previously viewed panel.

F8

(Next) Takes you to the next topic discussed.

F9

(Index) Displays the Help Index.

The Table of Contents Panel

This panel displays a list of topics for which Help is available. Simply tab to the topic you are interested in viewing and press Enter. Topic panels, in turn, allow you to make further selections.

```

userid          CA PMA/DataManager          mm/dd/yy hh:mm:ss
+-- DMTOPICH _ ----- TABLE OF CONTENTS ----- HELP ----+
|
| For more information on a topic, tab to that topic and press Enter.
|
|   __ Primary Panel
|   __ Input Pull-Down
|   __ Input Panels
|   __ Browse Committed IRDs
|
|   __ Output Pull-Down
|   __ Output Panels
|   __ Browse Committed ORDs
|
|   __ User Options Panel
|   __ Help with Help
|
|
| F1=Help F2=Topic F3=End F5=Cont F7=Prev F8=Next F9=Index
+-----+
  
```

Access

Topic Help panels appear when one of the following events occurs:

- You select **2. Table of Contents** from the Help pull-down.
- You press the TOPIC F key F2 on any Help panel.

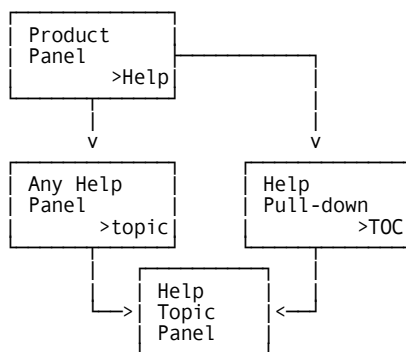

Actions

F1

(Help) Displays an explanation on how to use the Help facility.

F2

(Topic) Displays the Help Table of Contents.

F3

(End) Returns you to the resident product panel from which you called Help.

F5

(Cont) Takes you to the next logical panel.

F7

(Prev) Takes you to the previously viewed panel.

F8

(Next) Takes you to the next topic discussed.

F9

(Index) Displays the Help Index.

Topic Help Panel

A Topic panel appears when you make a selection on the Table of Contents panel. It provides you with an overview of the function you requested help for and with selections that take you to other panels containing more detailed information. The NEXT and PREV F keys take you to the next topic or previous help panel.

```

userid                      CA PMA/DataManager                      mm/dd/yy hh:mm:ss
+-- DMOPTNSH _ ----- OPTIONS ACTION ----- HELP ----+
|
| Choosing options from the Primary Panel's action bar displays the
| User Options panel. It contains options you can change from this
| time forward. After making your changes, be sure to SAVE them
| before leaving this panel.
|
| For information about these user options, tab to your selection and
| press Enter:
|
|      __ Warning Msgs                __ Mnemonics
|
|      __ Info Msgs                   __ Action Bar
|
|      __ Save/Delete Prompt          __ Database Depth
|
|      __ PF13-24 = PF1-12
|
|
| F1=Help F2=Topic F3=End F5=Cont F7=Prev F8=Next F9=Index
+-----+

```

Access

Topic Helps appear when one of the following events occurs:

- You press the NEXT F key F8 on any Help panel.
- You press the TOPIC F key F2 and select a topic from the Table of Contents panel.

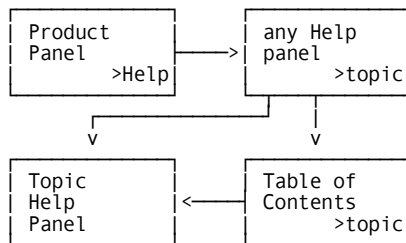

Actions

F1

(Help) Displays an explanation on how to use the Help facility.

F2

(Topic) Displays the Help Table of Contents.

F3

(End) Returns you to the resident product panel from which you called Help.

F5

(Cont) Takes you to the next logical panel.

F7

(Prev) Takes you to the previously viewed panel.

F8

(Next) Takes you to the next topic discussed.

F9

(Index) Displays the Help Index.

Index Help Panels

Index panels provide you with an alphabetical list of items for which Help is available. To make a selection, tab to the item you want information for and press Enter. This takes you to the Help panel that contains pertinent information.

```

userid          CA PMA/DataManager          mm/dd/yy hh:mm:ss
+-- DMINDX1H _ ----- INDEX:1 ----- HELP ----+
  0
  0 For more information on a subject, tab to that subject and press Enter.  0
  0
  0   __ Action bar                               __ Input Descriptions List panel  0
  0   __ Are You Sure window                     __ Input ID                      0
  0   __ Bkwd                                     __ Input pull-down              0
  0   __ Browse Committed IRDs panel             __ Input Record Definition panel 0
  0   __ Browse Committed ORDs panel            __ Input Record Description, brief 0
  0   __ CB-CONS                                 __ Input Record Description, complete 0
  0   __ CMD column                             __ IRD Name                     0
  0   __ Commit Input Record Definitions        __ ORD Name                     0
  0   __ Construct                              __ Output Commit Definition panel 0
  0   __ Data Has Not Been Saved window         __ Output Description List panel  0
  0   __ DD Name                                __ Output pull-down            0
  0   __ Deleting a field                       __ Output Record Definition panel 0
  0   __ Deleting a record                     __ Output Record Description panel 0
  0   __ Fast path                             __ Output Record Header panel   0
  0   __ Fwd                                   __ Primary Panel               0
  0                                           (continued)                    0
  0 F1=Help F2=Topic F3=End F5=Cont F7=Prev F8=Next F9=Index  0
+-----+
  
```

Access

The Index Help panel appears when you press the INDEX F key F9 on any Help panel.

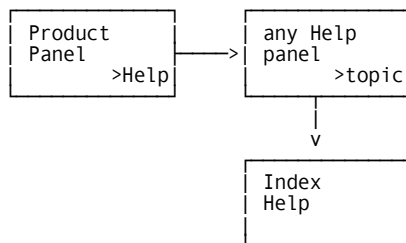

Actions

F1

(Help) Displays an explanation on how to use the Help facility.

F2

(Topic) Displays the Help Table of Contents.

F3

(End) Returns you to the resident product panel from which you called Help.

F5

(Cont) Takes you to the next logical panel.

F7

(Prev) Takes you to the previously viewed panel.

F8

(Next) Takes you to the next topic discussed.

F9

(Index) Displays the Help Index.

Actions

F1

(Help) Displays an explanation on how to use the Help facility.

F2

(Topic) Displays the Help Table of Contents.

F3

(End) Returns you to the resident product panel from which you called Help.

F5

(Cont) Takes you to the next logical panel.

F7

(Prev) Takes you to the previously viewed panel.

F8

(Next) Takes you to the next topic discussed.

F9

(Index) Displays the Help Index.

Chapter 6: DataManager Batch Processing and Reporting

The CAJRJCL library contains several sample batch jobs. Four of those jobs run a multi-purpose program called CAKSARCH which can archive, restore, copy and commit definitions. This means you can perform more than one type of function in the same run. The other programs perform normal DataManager processing and reporting. The referenced procedures in the table below can be found in the CAJRPROC library.

Program Name	What It Does	PROC Name	Required Control Statements	CAJRJCL Member Name
CAKSARCH	Archives the definitions you select	CAKSARES	BACKUP	CAKSARCH
CAKSARCH	Freezes input and output definitions	CAKSARES	COMMIT	CAKSCOMT
CAKSARCH	Copies definitions from a committed version for editing	CAKSARES	COPY	CAKSCPY
CAKSARCH	Restores the backup of committed records	CAKSARES	RESTORE	CAKSREST
CAKSNET8 CAKSNET9	Prepares CA Netman data for CAKSLOAD processing			CAKSNET8 CAKSNET9
CAKSLOAD	Processes input data using committed definitions		INPUT= OUTRECS=	CAKSLOAD
EARL	Lists the output data file.	CAKSEARL		CAKSORDS

The online component and each of these batch jobs references a file called CAIKSPAR. This chapter discusses the contents of the CAIKSPAR file and details about each of these batch jobs.

The Parameter Files

The CA PMA system requires two parameter files or sequential data sets to define information required for DataManager and CA PMA Chargeback online and batch processing. The CAIKSPAR file is used by DataManager and CA PMA Chargeback while the CAIKRPAR file is only used by CA PMA Chargeback. The parameter files are accessed during online and batch processing via the following ddnames: CAIKSPAR and CAIKRPAR.

Note: Both of these files are allocated and customized during installation.

CAIKSPAR Parameter File

The CAIKSPAR file provides DataManager and CA PMA Chargeback with specific information about the database system your installation uses, as well as defining the Company Name that appears on your reports.

This file also defines specific information required by DataManager for batch processing and CA PMA Chargeback processing, as well as specific keywords used by CA PMA Chargeback.

Note: The order in which you specify CAIKSPAR parameters is **unimportant**. You can abbreviate each keyword using the fewest characters that make it unique.

Caution: This parameter file should be defined only **once** - during implementation. It should then remain **static**. See CAIKSPAR Usage Considerations.

Database-Related Keywords

The following five parameters are used to specify the database product your installation uses. CA PMA Chargeback supports Advantage CA Datacom and IBM's DB2. Note that DATABASE_NAME is defined during installation. Use the table below as a guide in specifying the following parameters:

Parameter	DB2	CA Datacom
DATABASE_NAME =	PMA490	PMA490
PLAN_ID =	_____	N/A
SQL_TYPE =	DB2	CA Datacom
SUBSYSTEM_ID =	DB23	userid or ownerid
EURODB2 =	NO YES	N/A

DATABASE_NAME=

Indicates which database name to use for **documentation purposes only**. Up to 8 characters are permitted.

PLAN_ID=

This 1- to 8-character DB2 parameter is site-dependent.

- If you are using DB2 and require the PLAN_ID, **uncomment** the PLAN_ID and enter the PLAN_ID.
- If you are using DB2, but do not use the PLAN_ID, the PLAN_ID **must** remain as a comment.
- If you are using CA Datacom, the PLAN_ID **must** remain as a comment.

SQL_TYPE=

Specifies which type of SQL statements will be used by PMA. Valid choices are DB2 or DATACOM.

SUBSYSTEM_ID=

A 1- to 4-character SSID or driver used when DB2 links to data. For CA Datacom, SUBSYSTEM_ID should be the owner's ID.

EURODB2 =

Determines what value DB2 uses for the decimal point indicator and applies only to DB2 databases.

- If NO is specified or defaulted to, a period (.) is used as the decimal point indicator and a comma (,) is used to separate large whole numbers so they are presented in a more readable form.
- If YES is specified, a comma (,) is used as the decimal point indicator and a period (.) is used to separate large whole numbers so they are presented in a more readable form.

Keywords Used by Both DataManager and CA PMA Chargeback

The following keywords are used for DataManager batch processing and CA PMA Chargeback online functions (options).

CUSTOMER_NAME=

The company name (up to 25 characters) that you want to appear on your reports.

BASE_VERSION= (required)

The four-character required field must be either TEST or PROD. It specifies the DataManager version CA PMA Chargeback will validate its data against. For example: BASE_VERSION = TEST

CAIKSPAR Usage Considerations

Formatting Parameters

Put each CAIKSPAR parameter on a separate line. Order isn't important. Parameters can also be abbreviated by truncation.

Using more than one Parameter File

You may want to have two CAIKSPAR files: one for production (which will remain static) and a second file that you can change as required.

The Archive/Restore Program (CAKSARCH)

The CAKSARCH program is a multi-purpose program that performs specific CA PMA table maintenance functions. Table maintenance functions include:

- archiving tables or backing up definition tables
- restoring definition tables
- committing the DEVELOPMENT version of CA PMA definition tables so that these definitions can be used in processing
- copying committed definitions to the DEVELOPMENT version so that modifications can be made via the online facility

Note: All maintenance functions can be performed with a *single* execution of the program. When multiple maintenance functions are executed in this manner, table maintenance control statements are executed in the order they are specified.

The CAJRPROC member CAKSARES runs the program CAKSARCH. You **must** customize the CAKSARES PROC and either copy it to your system or user PROCLIB or use it instream within each of the JCL members.

Note: The Archive/Restore program's sole purpose is to archive specific tables used in CA PMA processing. It is **not** intended to replace full database backups or restores.

The next page contains a sample of the CAKSARES PROC, followed by a discussion that outlines each of the table maintenance functions by JCL member name contained in the CAJRJCL library.

JCL for Running the CAKSARCH Program

```

//*****
//* CAKSARES ARCHIVE/RESTORE PROC
//*
//* THIS PROC IS USED DURING:
//*
//* 1. ARCHIVING (BACKUP) OF TABLES
//* 2. RESTORING OF ARCHIVED TABLES
//* 3. COMMIT PROCESSING
//* 4. COPY PROCESSING
//*
//* REFER TO FOLLOWING SAMPJCL MEMBERS FOR DETAILS:
//*
//* 1. CAKSARCH - CA PMA/DM ARCHIVE
//* 2. CAKSREST - CA PMA/DM RESTORE
//* 3. CAKSCOMT - CA PMA/DM COMMIT
//* 4. CAKSCPY - CA PMA/DM COPY TABLES
//* 5. CAKRARCH - CA PMA/CB ARCHIVE
//* 6. CAKREST - CA PMA/CB RESTORE
//* 7. CAKRCOMT - CA PMA/CB COMMIT
//* 8. CAKRCPY - CA PMA/CB COPY TABLES
//*
//* ** IF YOUR DATABASE IS DB2, REMOVE THE DATACOM LIBRARIES AND **
//* ** THE DCIND SYMBOLIC, AND UNCOMMENT THE DB2 LIBRARY. **
//*
//*****
//CAKSARES PROC INDEX='CAI', /* DATA SET HIGH LEVEL QUALIFIER
//          DCIND='CAI', /* DATACOM HIGH LEVEL QUALIFIER
//          SYSOUT='*' /* SYSOUT CLASS
//*
//STEP010 EXEC PGM=CAKSARCH
//STEPLIB DD DSN=&INDEX..CAILIB,DISP=SHR
//          DD DSN=&INDEX..CAICICS,DISP=SHR
//          DD DSN=&DCIND..USERLOAD,DISP=SHR <-- DATACOM LIBRARY
//          DD DSN=&DCIND..INFOCAI.LOAD,DISP=SHR <-- DATACOM LIBRARY
//          DD DSN=&DCIND..LOAD,DISP=SHR <-- DATACOM LIBRARY
//*          DD DSN=SYS2.DSNLOAD,DISP=SHR <-- DB2 LIBRARY
//CAIKSPAR DD DSN=&INDEX..PMAPARM,DISP=SHR
//CAIKRPAR DD DSN=&INDEX..CBPARM,DISP=SHR
//SYSPRINT DD SYSOUT=&SYSOUT.
//SYSUDUMP DD SYSOUT=&SYSOUT.
//SYSIN DD DDNAME=SYSIN

```

The BACKUP Option

Archival/Backup of DataManager tables is performed using the BACKUP option of the CAKSARCH program described below.

```
▶▶ BACKUP - TBL=qualifier.tablename - DD=ddname ───────────────────────────────────▶
└──────────────────────────────────────────────────────────────────────────────────┘
└─ where_clause; ─┘
```

where:

TBL=

Specifies the fully qualified data set name of the table to be backed up. Since DataManager stores definitions in four tables (IRDDDESC, IRDTAB, ORDDDESC and ORDTAB), submit four BACKUP statements to archive all these tables in one run. All versions stored in each table will be backed up.

DD=

Specifies the ddname of the DD statement that describes the output data set. The DD statement specifies where this backup file will be created – on tape or disk. When archiving multiple tables, be sure to assign each table a unique ddname. Corresponding DD statements must also be defined.

where_clause (optional)

It is recommended that you always backup an entire table, which means you would not use a where_clause. However, if used, the where_clause can selectively backup specific records within a table, for example, **WHERE ORDID='MBJ'**. When creating where_clauses, refer to the field names listed in *Appendix C: DataManager Tables* and end the where_clause with a semicolon (;).

- If a where_clause is used, DataManager backs up the records that meet the where_clause's selection criteria.
- If a where_clause is omitted, DataManager backs up **all** records stored in the specified table.

Rules

- Never use a where_clause to backup tables.
- Never archive tables by their synonym name. **Always** specify the fully qualified table name or you will not be able to properly restore the tables.

Examples

```
BACKUP TBL=CAI.PMA.IRDESC.TABLE,DD=BIRDESC  
BACKUP TBL=CAI.PMA.IRDTAB.TABLE,DD=BIRDTAB  
BACKUP TBL=CAI.PMA.ORDDESC.TABLE,DD=BORDESC  
BACKUP TBL=CAI.PMA.ORDTAB.TABLE,DD=BORDTAB
```

These statements back up four CA PMA DataManager tables. You can submit all four statements in one CAKSARCH run.

JCL for Running the BACKUP Option

The JCL contains numbered instructions that explain what to do.

```
//USERIDAR JOB (00000000), 'DM/ARCH', CLASS=A, REGION=4M, MSGCLASS=X
//*
//*
//*****
//* USE THIS JCL TO ARCHIVE CA PMA/DM TABLES
//*
//* INSTRUCTIONS:
//* 1. THIS JCL WILL USE THE CAKSARES PROC
//*    PROVIDED IN THE SAMPJCL. EITHER COPY
//*    THE PROC TO THIS JCL OR ADD IT TO
//*    YOUR SYSTEM USER.PROCLIB.
//* 2. MODIFY THE JOB CARD ACCORDING TO
//*    YOUR INSTALLATION STANDARDS.
//* 3. CHANGE THE HIGH-LEVEL QUALIFIERS TO
//*    REFLECT THE CORRECT VALUES.
//* 4. MODIFY THE STEP010.SYSIN CONTROL
//*    STATEMENTS TO REFLECT THE TABLE(S)
//*    WHICH ARE TO BE ARCHIVED OR BACKED
//*    UP. BE SURE THAT A UNIQUE DDNAME IS
//*    INDICATED ON EACH DD STATEMENT.
//* 5. FOR EACH DDNAME INCLUDED IN
//*    STEP010.SYSIN, BE SURE THAT A
//*    CORRESPONDING DD STATEMENT IS
//*    DEFINED.
//*****
//*
//BACKUP EXEC PROC=CAKSARES,
//          CAI='CAI',
//          INDEX='CAI.PMACB',
//          SYSOUT='*'
//*
//*****
//* THE CONTROL STATEMENTS ARE PASSED TO THE
//* CAKSARES PROC BY THE STEP010.SYSIN DD.
//* MODIFY AS OUTLINED IN STEP 5.
//*****
//*
//STEP010.SYSIN DD *
  BACKUP TBL=USERID.IRDESC, DD=BACKTAB1
  BACKUP TBL=USERID.IRDTAB, DD=BACKTAB2
  BACKUP TBL=USERID.ORDDESC, DD=BACKTAB3
  BACKUP TBL=USERID.ORDTAB, DD=BACKTAB4
//*
//*****
//* ADD THE APPROPRIATE NUMBER OF DD STATEMENTS
//*****
```

```

/**
//BACKTAB1 DD DSN=USERID.IRDDESC.ARCH,DISP=(NEW,CATLG,DELETE),
//          DCB=(DSORG=PS,RECFM=VB,LRECL=4096,BLKSIZE=9192),
//          UNIT=SYSDA,SPACE=(TRK,(10,)),VOL=SER=DVOL
//BACKTAB2 DD DSN=USERID.IRDTAB.ARCH,DISP=(NEW,CATLG,DELETE),
//          DCB=(DSORG=PS,RECFM=VB,LRECL=4096,BLKSIZE=9192),
//          UNIT=SYSDA,SPACE=(TRK,(10,)),VOL=SER=DVOL
//BACKTAB3 DD DSN=USERID.ORDDESC.ARCH,DISP=(NEW,CATLG,DELETE),
//          DCB=(DSORG=PS,RECFM=VB,LRECL=4096,BLKSIZE=9192),
//          UNIT=SYSDA,SPACE=(TRK,(10,)),VOL=SER=DVOL
//BACKTAB4 DD DSN=USERID.ORDTAB.ARCH,DISP=(NEW,CATLG,DELETE),
//          DCB=(DSORG=PS,RECFM=VB,LRECL=4096,BLKSIZE=9192),
//          UNIT=SYSDA,SPACE=(TRK,(10,)),VOL=SER=DVOL

```

Sample output generated by this job is shown below.

BACKUP Output

When DataManager successfully backs up your table, you'll receive printed output like this:

```

COMPANY NAME          ARCHIVE/RESTORE PROGRAM          PAGE  1
CA PMA/DM 1.0         REPORT                          Thu Oct 04 09:35:09 1990
109010KS100
        USING: DATABASE=, SUBSYS=DB23, WHATSQL=DB2

INPUT:
BACKUP TBL=USERID.IRDDESC,DD=BACKTAB1

SQL: SELECT * FROM USERID.IRDDESC
CAKS639I: NUMBER OF ROWS PROCESSED=26
CAKS607I: BACKUP PROCESSING COMPLETED SUCCESSFULLY

```

```

Customer_name        ARCHIVE/RESTORE PROGRAM          PAGE  2
CA PMA/DM 1.0         REPORT                          Thu Oct 04 09:35:09 1990
109010KS100
        USING: DATABASE=, SUBSYS=DB23, WHATSQL=DB2

INPUT:
BACKUP TBL=USERID.IRDTAB,DD=BACKTAB2

SQL: SELECT * FROM USERID.IRDTAB
CAKS639I: NUMBER OF ROWS PROCESSED=34
CAKS607I: BACKUP PROCESSING COMPLETED SUCCESSFULLY

```

USING: DATABASE, SUBSYS, WHATSQL

Displays EXEC parm and CAIKSPAR values that impact this run.

INPUT

Displays the BACKUP control statement submitted with this run. Each BACKUP statement you submit is processed separately and the results appear on separate pages.

SQL

Displays the SQL statement DataManager submits to the database to backup this table.

CAKS messages

Tells what happens while the job is running.

INPUT

Results from each control statement appear on a separate page. B and E on this report show output from the first two BACKUP statements following STEP010.SYSIN on the preceding page.

The RESTORE Option

The restore job is **not** intended to replace full database restores. Instead, it is provided as a means to restore specific tables used with DataManager.

Caution: If you run backups using a where_clause, be extremely careful when restoring tables. The contents of the designated table will be deleted before restore processing, and only archived records will be restored.

The RESTORE control statement identifies which backup table contains the definitions you want restored and the ddname of the file you want replaced. One run can process multiple RESTORE statements.

▶▶ RESTORE [TBL=qualifier.tablename] DD=ddname [INS] ▶▶

where:**TBL= (optional)**

Specifies the fully qualified data set name of the table to be restored. This program can restore to a new or existing table. If TBL= specifies a new table, the table is allocated before the archived table is restored. If TBL= is omitted, the table stored in the backup file will be used. Since DataManager stores definitions in four tables (IRDDDESC, IRDTAB, ORDDDESC and ORDTAB), submit four RESTORE statements to restore all these tables in one run.

DD=

Gives the ddname of the associated JCL DD statement that describes the backup data set. The information from this data set is copied into the TBL file specified in the RESTORE control statement. When restoring multiple tables, be sure each table has a unique ddname.

INS (optional)

If specified, RESTORE output will list the insert statements processed during this run. Omit INS to suppress this printed output.

Examples

```
RESTORE DD=BKUP2,INS
```

Restores the records in the BKUP2 dataset to the table name from which it originated. The SQL insert statements will be listed.

```
RESTORE TBL=CAIUSER.ORDTAB,DD=BKUP1
```

Restores records in the BKUP1 dataset to table CAIUSER.ORDTAB.

JCL for Running the RESTORE Option

The JCL contains numbered instructions that tell you what to do.

```
//USERIDDM JOB (40900000), 'DM/RESTORE', CLASS=B, REGION=4M, MSGCLASS=X
//*****
//* USE THIS SAMPJCL TO RESTORE CA PMA/DM
//* TABLES.
//*
//*** INSTRUCTIONS:
//* 1. THIS JCL WILL USE THE CAKSARES PROC
//* PROVIDED IN THE SAMPJCL. EITHER
//* COPY THE PROC TO THIS JCL OR ADD IT
//* TO YOUR SYSTEM USER.PROCLIB.
//* 2. MODIFY THE JOB CARD ACCORDING TO
//* YOUR INSTALLATION STANDARDS.
//* 3. CHANGE THE PARM VALUE ON THE EXEC
//* STATEMENT TO SPECIFY THE APPROPRIATE
//* DATABASE TO BE REPLACED. IF PARM IS
//* NOT DEFINED, IT WILL DEFAULT TO THE
//* DEFAULT DATABASE.
//* 4. CHANGE THE HIGH-LEVEL QUALIFIERS TO
//* REFLECT THE CORRECT VALUES.
//* 5. MODIFY THE STEP010.SYSIN DD
//* STATEMENT TO REFLECT THE TABLE(S)
//* THAT YOU DESIRE TO RESTORE.
//* 6. FOR EACH DD NAME THAT IS DEFINED TO
//* THE STEP010.SYSIN, BE SURE THAT ITS
//* DD STATEMENT HAS ALSO BEEN DEFINED.
//*****
//*
//*****
//* IF THE TABLE IS TO BE RESTORED TO ANOTHER
//* DATABASE, BE SURE TO CHANGE THE PARM
//* NAME ON THE EXECUTE STATEMENT.
//*****
//*
//RESTORE EXEC PROC=CAKSARES, PARM=' ,xxxxxx',
// CAI='CAI',
// INDEX='CAI.PMACB',
// SYSOUT='*'
//*
//*****
//* FOR EACH TABLE TO BE RESTORED, A RESTORE
//* STATEMENT MUST BE DEFINED.
//*****
//*
//STEP010.SYSIN DD *
//* RESTORE TBL=USERID.ORDTAB, DD=BACKTAB
//*
```

```

//*****
/* ADD THE APPROPRIATE NO. OF DD STATEMENTS
//*****
/*
//BACKTAB DD DSN=CAI.ORDTAB.ARCH,DISP=SHR
/*

```

Sample output generated by this job is shown below.

RESTORE Output

When DataManager successfully backs up your table, you'll receive printed output like this:

```

COMPANY NAME          ARCHIVE/RESTORE PROGRAM          PAGE  1
CA PMA/DM 1.0 9010KS100      REPORT          Thu Nov 08 13:26:47 1990
                USING: DATABASE=DSNDB04, SUBSYS=DB23, WHATSQL=DB2

INPUT:
RESTORE TBL=CAI.RESTIRD,DD=BACKTAB

FILE HEADER LINE=** TABLE=CAI.IRDDESC COLS=9  on 10/4/1990 11:11:51 AM

SQL:
CREATE TABLE  CAI.RESTIRD
VERSION CHAR(4),
DATASET CHAR(7),
IRIDID CHAR(8),
DESCRIPT CHAR(20),
ORIGIN CHAR(1),
IDBEGPOS CHAR(5),
IDLENGTH CHAR(2),
IDHEXVAL CHAR(20),
LENGTH CHAR(5)) IN DATABASE DSNDB04

CAKS632I - TOTAL NUMBER OF ROWS PROCESSED=30
CAKS611I - RESTORE PROCESSING COMPLETED SUCCESSFULLY

```

INPUT:

Displays the RESTORE control statement processed during this run.

SQL:

Displays the SQL statement DataManager submits to the database to restore this table.

CAKS messages

Tell what happens while this job is processing.

The COMMIT Option

DataManager definitions are modified by editing the DEVELOPMENT version of definition records using the DataManager online facility. Definitions in the DEVELOPMENT version are **not available** for processing until they are committed or frozen.

The commit process:

- **Freezes** all definitions in the DEVELOPMENT version of DataManager's tables
- **Deletes** any existing committed definitions from DataManager tables
- **Changes** the version of DEVELOPMENT definitions. IRD definitions change to the REAL version while ORD definitions change to TEST or PROD (depending on the version specified in the COMMIT control statement)

To commit DEVELOPMENT definitions, execute the Archive/Restore program (CAKSARCH) using the COMMIT control statement described below. The JCL to execute the COMMIT control statement is contained in the CAI.SAMPJCL member called CAKSCOMT.

An optional CA Earl definition file (CAIKSERL) can be generated during the commit process. To generate this file, include an CAIKSERL DD statement in the COMMIT JCL. The resulting CAIKSERL file contains CA Earl record definitions (DEF statements) for all ORD records being committed. These DEF statements are needed to produce CA Earl reports about the contents of the output data file.

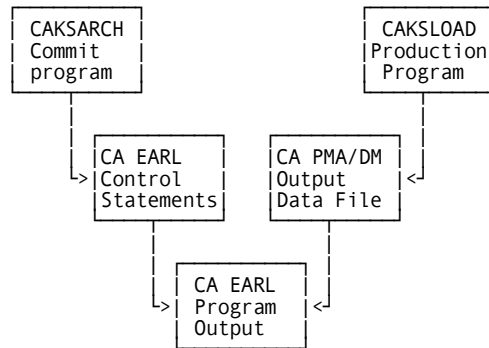

Commit jobs only require one control statement: COMMIT DM. No matter which form you use, COMMIT erases existing REAL IRDs and moves IRDs from the DEVELOPMENT version into the REAL version. ORD definitions in the DEVELOPMENT version are moved into the TEST or PROD version, depending on which you specify on the COMMIT DM statement. After a CAKSCOMT run, the DEVELOPMENT version is empty: all IRDs and ORDs in the DEVELOPMENT version have been moved.

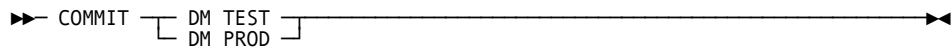

where:

TEST

Moves ORDs from the DEVELOPMENT version into the TEST version and IRDs from the DEVELOPMENT version into the REAL version, leaving the DEVELOPMENT version empty.

PROD

Moves ORDs from the DEVELOPMENT version into the PROD version and IRDs from the DEVELOPMENT version into the REAL version, leaving the DEVELOPMENT version empty.

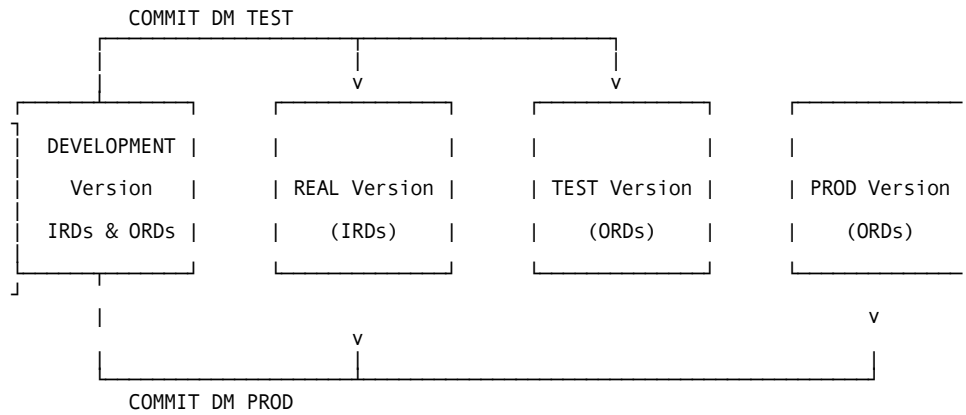

The CAIKSERL DD Statement

The commit job can produce a sequential data set containing CA Earl statements that define the content of the output data file. The CA Earl program uses this data set to print the data values CAKSLOAD stores in the output data file.

To create this data set, include an CAIKSERL DD statement in the COMMIT JCL with the following required attributes:

```
CAIKSERL DSN=xx.ORD.TEST,DCB=(RECFM=FB,LRECL=80,BLKSIZE=80,DSORG=PS)
```

Rule:

Use a data set naming convention that includes the version. This will allow you to list the records generated by both the TEST and PROD versions.

The space required for this file varies depending on the number of definitions in the committed version of the table.

If you don't want the CA Earl program to print the output data file, change the CAIKSERL statement to DD DUMMY.

If you omitted the CAIKSERL DD statement but you still want to run an output file listing:

- Run CAKSARCH with the COPY option to create a new DEVELOPMENT version
- Immediately run CAKSARCH with the COMMIT option and the CAIKSERL DD statement.

JCL for Running the COMMIT Option

The JCL contains numbered instructions that tell you what to do.

```
//CAKSCOMT JOB (ACCTINFO), 'PMGR', CLASS=B, REGION=4M, MSGCLASS=X
//*****
/* PURPOSE: USE THIS JCL FOR COMMIT PROCESSING FOR DATAMANAGER
/*      TABLES.
/*
/* INSTRUCTIONS:
/* 1. THIS JCL USES THE CAKSARES PROC PROVIDED IN THE SAMPJCL.
/*     EITHER COPY THIS JCL TO THIS JCL OR ADD TO YOUR SYSTEM
/*     USER.PROCLIB.
/* 2. MODIFY THE JOB CARD ACCORDING TO YOUR INSTALLATION STANDARDS.
/* 3. CHANGE THE HIGH LEVEL QUALIFIERS TO REFLECT THE CORRECT
/*     QUALIFIER.
/* 4. CHANGE THE SYSOUT SYMBOLIC TO REFLECT THE APPROPRIATE SYSOUT
/*     CLASS.
/* 5. IF YOU WILL BE USING CA EARL TO PRINT THE ORD DATA FILE, THE
/*     CAIKSERL DD STATEMENT MUST BE PRESENT DURING COMMIT PROCESSING.
/*     OTHERWISE COMMENT OR REMOVE THE CAIKSERL DD.
/* 6. BE SURE TO MODIFY THE STEP010.SYSIN DD STATEMENT TO REFLECT
/*     THE APPROPRIATE VERSION TO BE COMMITTED.
//*****
//COMMIT EXEC CAKSARES,
//      INDEX='CAI',      /* DATA SET HIGH LEVEL QUALIFIER
//      DCIND='CAI',      /* DATACOM HIGH LEVEL QUALIFIER
//      SYSOUT='*'        /* SYSOUT CLASS
//*****
/* REMOVE OR COMMENT OUT THE CAIKSERL DD STATEMENT IF YOU DO NOT
/* DESIRE TO GENERATE THE CA EARL RECORD DEFINITION STATEMENTS.
//*****
/*
//CAIKSERL DD DSN=&INDEX..ORD.EARLDEF,          <-- CUSTOMIZE
//      DISP=(NEW,CATLG,DELETE),
//      UNIT=DISK,DCB=(RECFM=FB,LRECL=80,BLKSIZE=80,DSORG=PS),
//      VOL=SER=DSKVOL,SPACE=(CYL,(1,1),RLSE)
//*
//*****
/* BE SURE TO CHANGE THE COMMIT STATEMENT TO
/* REFLECT THE APPROPRIATE CA PMA APPLICATION
/* AND VERSION TO BE COMMITTED.
//*****
/*
//STEP010.SYSIN DD *
COMMIT DM TEST
/*
```

Sample output generated by this job is shown below.

COMMIT Output

When DataManager successfully backs up your table, you'll receive printed output like this:

```
COMPANY NAME          ARCHIVE/RESTORE PROGRAM          PAGE 1
CA PMA/DM 1.0 9010KS100          REPORT          Tue Nov 06 10:40:32 1990
                               USING: DATABASE=, SUBSYS=DB23, WHATSQL=DB2

INPUT:
COMMIT DM TEST
```

```
CA PMA/DM 1.0 9010KS100          COMMIT          PAGE 1
                               CONTROL REPORT          Tue Nov 06 10:40:36 1990

CAKS689I - COMMIT TYPE: DM
CAKS689I - DATAMANAGER VERSION: TEST
CAKS668I - ALL ELEMENTS ARE DEFINED
CAKS690I - DATABASE COMMIT BEING PERFORMED.
CAKS613I - COMMIT PROCESSING COMPLETED SUCCESSFULLY
```

INPUT

Displays the COMMIT control statement submitted with this run. CAKSARCH can only process one COMMIT statement per run.

CAKS messages

Tell what happens while the job is running.

JCL for Running the COPY Option

The JCL contains numbered instructions that tell you what to do.

```
//USERIDDM JOB (00000000), 'DM/COPY', CLASS=B, REGION=4M,
// MSGCLASS=X
/*
//*****
/* USE THIS JCL TO COPY A COMMITTED VERSION
/* OF THE CA PMA/DATAMANAGER TABLE TO THE
/* DEVELOPMENT VERSION.
/* INSTRUCTIONS:
/* 1. THIS JCL WILL USE THE CAKSARES PROC
/* PROVIDED IN THE SAMPJCL. EITHER COPY
/* THAT PROC TO THIS JCL OR ADD IT TO
/* YOUR SYSTEM USER.PROCLIB.
/* 2. MODIFY THE JOB CARD ACCORDING TO
/* YOUR INSTALLATION STANDARDS.
/* 3. CHANGE THE HIGH-LEVEL QUALIFIERS TO
/* REFLECT THE CORRECT VALUES.
/* 4. MODIFY THE STEP010.SYSIN CONTROL
/* STATEMENTS TO REFLECT THE APPROPRIATE
/* PARAMETERS FOR PROCESSING.
//*****
//COPY EXEC PROC=CAKSARES,
// CAI='CAI',
// INDEX='CAI.PMACB'
/*
//*****
/* THE CONTROL STATEMENTS ARE PASSED TO THE
/* CAKSARCH PROC BY THE STEP010.SYSIN DD.
/* MODIFY AS OUTLINED IN STEP 4
//*****
/*
//STEP010.SYSIN DD *
COPY DM PROD REFRESH
```

Sample output generated by this job is shown next.

COPY Output

When DataManager successfully copies your table, you'll receive printed output like this:

```

COMPANY NAME          ARCHIVE/RESTORE PROGRAM          PAGE   1
CA PMA/DM 1.0 9010KS100      REPORT      Wed Oct 17 14:53:23 1990
      USING: DATABASE=, SUBSYS=DB23, WHATSQL=DB2

INPUT:
COPY DM PROD REFRESH
CAKS563I Processing Table: ORDTAB
CAKS564I Processing Complete for: ORDTAB
CAKS563I Processing Table: ORDDESC
CAKS564I Processing Complete for: ORDDESC
CAKS563I Processing Table: IRDTAB
CAKS564I Processing Complete for: IRDTAB
CAKS563I Processing Table: IRDDESC
CAKS564I Processing Complete for: IRDDESC
CAKS575I END OF PROCESSING (0)
CAKS615I - COPY PROCESSING COMPLETED SUCCESSFULLY

```

The Input section displays the COPY control statement processed during this run.

DataManager messages tell you the status of execution.

How COPY and COMMIT Impact Tables

Since DataManager stores all versions together within one set of tables, it's important to know how steps like COMMIT and COPY work. Review the charts below to see how COMMIT and COPY impact the number of records stored in these tables.

IRDDESC Table

Action	DEVL	REAL	Total
Start with no records defined.			
Define 10 IRDs and 10 ORDs.	10		10
Commit records to TEST version.		10	10
Copy TEST version.	10	10	20
Commit DEVELOPMENT records to PROD.		10	10
Copy PROD version.	10	10	20

ORDDESC Table

Action	DEVL	TEST	PROD	Total
Start with no records defined.				
Define 10 IRDs and 10 ORDs.	10			10
Commit records to TEST version.		10		10
Copy TEST version.	10	10		20
Commit DEVELOPMENT records to PROD.		10	10	20
Copy PROD version.	10	10	10	30

These descriptions correspond to the six actions in the table above:

1

Suppose these tables are empty when you start using DataManager.

2

The records you input using the online facility always belong to the DEVELOPMENT version.

3

COMMIT DM TEST moves all your DEVELOPMENT IRDs to the REAL version and all your DEVELOPMENT ORDs to the TEST version. Now there are no DEVELOPMENT records. CAKSLOAD production runs can now begin using the TEST version.

4

You want to continue refining your definitions, so **COPY DM TEST REFRESH** copies your TEST and REAL definitions back to the DEVELOPMENT version. You do this because only the DEVELOPMENT version can be edited.

5

When you've finished refining these definitions, commit them for production (the PROD version) using **COMMIT DM PROD**. The refined IRDs replace the old REAL definitions and there are no more records in the DEVELOPMENT version. Now you can run production jobs from either the PROD or TEST version.

6

To further refine your definitions, copy the latest version (PROD) using **COPY DM PROD REFRESH**. This copies your latest definitions into the DEVELOPMENT version so you can continue editing.

This example illustrates the advantages of keeping a log of COMMIT and COPY processing.

The CA Netman Data Converter (CAKSNET8 and CAKSNET9)

Users preparing CA Netman data for processing must execute this step because the files produced by the CA Netman 318/319 programs don't have dates and times stored in their records. This step runs an interface program that appends a date and time to the CA Netman records. No other transformation is done. The output is ready for daily processing by DataManager.

This discussion of the CAKSNET8 and CAKSNET9 programs is divided into several sections:

- designating a date and time
- the ddnames used by this step
- the JCL for running CAKSNET8 and CAKSNET9
- the CAKSNET8/9 output

Designating a Date and Time

Date defaults to the current system date. However, you can override the current date by defining a parameter file. That file should be a sequential 80-byte card image file containing a single record. The format of this record must be:

Column No:	1 2 3 4 5	6 7 8 9	0 1 2 3	4 5 6 7
Input:	D A T E =	y y /	m m /	d d

For example, DATE=91/04/01.

Time is always set to 00:00:01. There is no method for overriding this default time.

DDNAMEs Required by This Step

DDNAME	File to which it must be assigned
CAKSNETI	The original file produced by CA Netman
CAKSNETO	The newly created output file generated by this step
CAKSNETP	The parameter file where the date is stored

The JCL for Running CAKSNET8

```
//CONVJOB JOB .....
//JOB LIB DD DSN=CAI.CAILIB,DISP=SHR <---- CUSTOMIZE
//STEP1 EXEC PGM=CAKSNET8
//CAKSNETI DD DSN=NETMAN.318.OUTPUT,DISP=SHR <---- CUSTOMIZE
//CAKSNETO DD DSN=PMA.NETMAN.318.FILE,DISP=OLD <---- CUSTOMIZE
//CAKSNETP DD *
DATE=91/04/01
```

This JCL processes 318 input files. To process 319 files, make the following changes:

- Change the program name in STEP1 to CAKSNET9.
- Change the CAKSNETI and CAKSNETO DD statements to point to the 319 files.

Note that 318 and 319 files must be processed in separate steps.

Output From CAKSNET8

```
CA/PMA-DM 1.0 9104KS100          NETMAN 318 FILE PROGRAM PROCESSING          PAGE 1
                                     Wednesday 5/1/1991

CAKS701I - no parm specified - taking today's date
Records processed = 4471

Normal Termination
```

CAKS701I

This message indicates the method used for assigning dates.

Records processed

This line reports how many records were processed.

Normal Termination

Tells you the job ran successfully to completion.

DataManager Daily Processing (CAKSLOAD)

The DataManager load program, CAKSLOAD, uses committed definitions from the IRD and ORD tables to process data files from a variety of sources. CAKSLOAD generates one composite data file that can be used by other PMA applications. An optional user exit called CA\$KREX is also provided for your convenience (see The CA\$KREX User Exit for CAKSLOAD for details).

This process references the CAIKSPAR file as well as specific CAKSLOAD control statements. CAKSLOAD control statements define:

- what input files are to be used
- what ORD names are to be selected from the input file(s) for processing and written to the output data file
- what error handling procedures to follow

If any invalid records are encountered during this process, certain control statements determine whether these errors are written to a file. Errors written to disk can be corrected and recycled as input to the next CAKSLOAD run.

This discussion of the CAKSLOAD program is divided into several sections:

- control statements for CAKSLOAD (required and optional)
- processing requirements
- processing recommendations
- preparation overview
- the JCL for running CAKSLOAD
- the CA\$KREX user exit
- CAKSLOAD output

Daily Processing Options

CAKSLOAD jobs can process seven different kinds of control statements, as summarized below:

Required or Optional	Statement Type	Control Statement	Purpose
Required	Input	INPUT	Defines data sets containing input data.
Required	Output	OUTREC	Selects which ORD names are to be processed and retained on the output data

Required or Optional	Statement Type	Control Statement	Purpose
			file.
Optional	Output File	OUTPUT	Defines the JCL DDNAME of the output data file.
Optional	Error Handling	RECYCLE OUTPUT	Writes invalid records found during processing to a sequential file.
Optional	Error Handling	RECYCLE INPUT	Processes corrected RECYCLE OUTPUT records.
Optional	Error Handling	ERRORS	Defines the error threshold before processing terminates. Required when you RECYCLE OUTPUT.
Optional	Reporting	LINES	Defines the number of lines per page for the CAKSLOAD control reports.

Each of these statements are discussed in detail later in this section.

Combine these control statements according to these guidelines:

- Put each statement on a separate line.
- When listing ddnames or ORD names, use a comma to separate entries.
- If a control statement doesn't fit on one line, end that line with a dash (-) to indicate continuation on the next line.

Required Statements

INPUT Statement

Defines the ddnames of *data sets* from which DataManager will acquire input data. Use as many INPUT control statements as necessary. Default: none

▶▶ INPUT - internal-ddname= [JCL-ddname (JCL-ddname, JCL-ddname, ...)] ▶▶

where:

ALL

Outputs all records specified on the INPUT statement to the output data file.

ord-name

Specifies one or more ORD Names that DataManager will include in the output data file. Default: none. These ORD names are derived from the field called **ORD Name** on the Output Record Description panel (below).

```

userid          CA PMA/DataManager          09/26/90 11:07:55
-----
  Input  Output  oPtions  Exit  Help
+-- BAODESP -----Output Record Description -----+
  0 Panel  Exit  Help                                     0
  0 -----+-----+-----+-----+-----+-----+
  0 Enter a New Output Record Description or Browse ORDs 0
  |
  0 > ORD Name . . . . . MBJ                               0
  0 Description . . . . . MVS - BATCH JOB                 0
  0
  0 F2=Create   F11=Browse                                0
+-----+-----+-----+-----+-----+-----+
  
```

Note: The OUTREC statement defines the ORD name while the INPUT statement defines the internal and JCL ddnames. DataManager implicitly references the ORD tables to identify which IRDs go with these ORDs.

Examples

OUTREC=ALL

Outputs all records specified on the INPUT statement to the output data file.

OUTREC=MBJ

Selects the input record which corresponds to the ORD Name MBJ.

OUTREC=(MBJ, MBS, MBI, MCT)

Outputs these four ORD names to the output data file.

RECYCLE INPUT Statement

The ddname of the data set that contains corrected data from a previous run. Omitting a ddname on the RECYCLE INPUT statement invokes the default value. Omitting this control statement prevents DataManager from processing corrections.

Default: RECYCLE INPUT=CAIKSRI

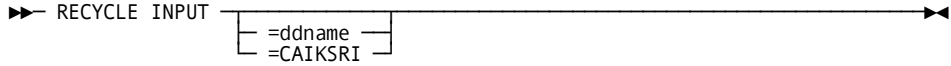

Examples

```
OUTREC=ALL
INPUT JARS=CAIKSJR
INPUT VGENJOB=CAIKSVC
```

These control statements process input data stored in data sets with internal ddnames JARS and VGENJOB. ERRORS defaults to zero which means the run will terminate the first time it encounters an error. Most users set ERRORS > 0.

```
OUTREC=ALL
INPUT JARS=CAIKSJR
ERRORS=20
```

This run processes data stored in the data set with JCL ddname of CAIKSJR. The first twenty errors are printed out. Any more errors will make CAKSLOAD terminate. To correct definitions, you must work from this printout.

```
OUTREC=ALL
INPUT JARS=CAIKSJR
ERRORS=20
RECYCLE INPUT
RECYCLE OUTPUT
```

The first twenty errors are printed out and written to the file whose ddname is CAIKSRO. Now you can correct these errors online. More than twenty errors causes the run to abend. This run also processes corrected records that were errors in some previous run. The file with the corrected records uses the default ddname of CAIKSRI.

Processing Requirements

Memory Requirements

All referenced IRD and ORD definitions are loaded into memory during the initial startup phase of CAKSLOAD. If the region size is too small, the CAKSLOAD process terminates. Termination happens because of performance considerations: A larger region results in fewer DASD accesses which yields faster throughput. Therefore, limit the OUTREC control statement to only those definitions that are required.

Storage Requirements

The amount of temporary work area needed on DASD units varies depending upon the volume of data to be processed and the type of DASD unit being used.

The amount of permanent disk space needed for the output data file and the error files also varies depending on the volume of data being processed and the type of DASD unit used.

Processing Recommendations

Establish Generation Data Groups to define the data set names used for the output data file and the error files. This approach eliminates the need for continual JCL modifications to CAKSLOAD.

JCL Statements

```
//CAIKSOP DD DSN=PMA.ORD.DATA.FILE(+1)
```

Outputs a new data file each time CAKSLOAD runs.

```
//CAIKSRI DD DSN=PMA.ORD.ERROR.FILE(0)
```

Inputs the corrected error file from the last CAKSLOAD run.

```
//CAIKSRO DD DSN=PMA.ORD.ERROR.FILE(+1)
```

Creates a new error file each time CAKSLOAD runs.

Preparation Overview

Follow these three steps when preparing to run CAKSLOAD:

- Determine the CAKSLOAD control statements which will be used.
- Ensure that all DD statements exist in the JCL.
- Review the contents of the CAIKSPAR data set to ensure that BASE_VERSION is set to the correct version.

JCL for Running Daily Processing

The JCL contains numbered instructions that tell you what to do.

```
//CAKSLOAD JOB (ACCTINFO), 'PMGR', CLASS=A, REGION=4M, MSGCLASS=X
//*
//*****
/* PURPOSE: THIS JOB STREAM WILL USE THE COMMITTED
/*          VERSION OF THE CA PMA/DATAMANAGER TABLE TO
/*          PROCESS SELECTED DATA FILES.
/*
/* INSTRUCTIONS:
/*
/* 1. CUSTOMIZE THE INSTREAM SYMBOLICS.
/* 2. IF YOUR DATABASE IS DB2, REMOVE THE DATACOM
/*    LIBRARIES AND UNCOMMENT THE DB2 LIBRARY.
/* 3. CUSTOMIZE THE CAIKSJR DD STATEMENT TO REFLECT
/*    THE DD NAME UTILIZED IN THE INPUT CONTROL
/*    STATEMENT AND TO CUSTOMIZE THE DD DATA SET NAME.
/* 4. CUSTOMIZE THE CAIKSOP DATA SET NAME.
/* 5. IF THE RECYCLE INPUT CONTROL STATEMENT WILL BE
/*    SPECIFIED, CUSTOMIZE THE DATA SET NAME OF THE
/*    CAIKSRI DD STATEMENT. IF THIS STATEMENT WILL NOT BE
/*    USED, REMOVE OR COMMENT OUT THIS STATEMENT.
/* 6. IF THE RECYCLE OUTPUT CONTROL STATEMENT WILL BE
/*    SPECIFIED, CUSTOMIZED THE DATA SET NAME OF THE
/*    CAIKSRO DD STATEMENT. IF THIS STATEMENT WILL NOT
/*    BE USED, REMOVE OR COMMENT OUT THIS STATEMENT.
//*****
//CAKSLOAD PROC INDEX='CAI',          /*DATASET
//          DCIND='CAI',              /*DATACOM
//          DVOL='CAIVOL',            /*VOL SER OF DASD
//          PERMDA='DISK',             /*PERM DASD NAME
//          SYSOUT='*'                 /*SYSOUT CLASS
//STEP1   EXEC PGM=CAKSLOAD
//STEPLIB DD DSN=&INDEX..CAILIB, DISP=SHR
//          DD DSN=&INDEX..CAICICS, DISP=SHR
//          DD DSN=&DCIND..USERLOAD, DISP=SHR          <-- DATACOM
//          DD DSN=&DCIND..INFOCAI.LOAD, DISP=SHR     <-- DATACOM
//          DD DSN=&DCIND..LOAD, DISP=SHR             <-- DATACOM
//          DD DSN=SYS2.DSNLOAD, DISP=SHR            <-- DB2
//SYSOUT  DD SYSOUT=&SYSOUT.
/*
//*****
/* THE CA PMA/DM LOAD CONTROL REPORTS WILL BE
/* OUTPUT TO THE SYSPRINT DD STATEMENT.
//*****
/*
//SYSPRINT DD SYSOUT=&SYSOUT.
/*
```

```

//*****
/* THE CAIKSPAR DD STATEMENT DEFINES THE DATA SET
/* NAME OF THE CA PMA GLOBAL PARAMETER FILE WHICH
/* WILL BE ACCESSED DURING PROCESSING.
//*****
/*
//CAIKSPAR DD DSN=&INDEX..PMAPARM,DISP=SHR
/*
//*****
/* THE CAIKSJR DD STATEMENT DEFINES THE INPUT
/* DATA SET NAME OF THE FILE TO BE PROCESSED.
/* THE DDNAME TO BE USED IS VARIABLE. THE DDNAMES
/* ARE DEFINED DURING IRD RECORD DEFINITION
/* ACCOMPLISHED VIA THE CA PMA/DM ONLINE FACILITY.
//*****
/*
//CAIKSJR DD DSN=CAI.JARSPMA.HISTORY.CHARGS7,          <---- CUSTOMIZE
//          DISP=SHR
/*
//*****
/* THE CAIKSRI DD STATEMENT DEFINES THE INPUT
/* DATA SET NAME OF THE CORRECTED ERROR FILE WHICH
/* WILL ALSO BE INPUT IN THIS PROCESS. USE THIS DD
/* STATEMENT IN CONJUNCTION WITH THE FOLLOWING DM
/* CONTROL STATEMENT:
/*
/* RECYCLE INPUT
//*****
/*
/*CAIKSRI DD DSN=&INDEX..DM.ORD.ERROR.FILE,DISP=SHR <----- CUSTOMIZE
/*
//*****
/* THE CAIKSOP DD STATEMENT DEFINES THE DATA SET
/* NAME OF THE ORD DATA FILE WHICH WILL BE
/* CREATED DURING THIS PROCESS.
//*****
/*
//CAIKSRO DD DSN=&INDEX..DM.ORD.ERROR.FILE(0),          <----- CUSTOMIZE
//          UNIT=&PERMDA.,                               <----- CUSTOMIZE
//          DISP=(NEW,CATLG,DELETE),
//          DCB=(RECFM=V,LRECL=32000,BLKSIZE=32760,DSORG=PS),
//          VOL=SER=&DVOL.,
//          SPACE=(TRK,(10,10))
/*
//*****
/* THE CAIKSRO DD STATEMENT DEFINES THE OUTPUT
/* DATA SET NAME OF THE ERROR FILE WHICH MAY BE
/* CREATED DURING THIS PROCESS. USE THIS DD
/* STATEMENT IN CONJUNCTION WITH THE FOLLOWING DM

```

```

/* CONTROL STATEMENTS:
/*
/* RECYCLE OUTPUT AND ERRORS.
/******
/*
/*CAIKSRO DD DSN=&INDEX. .DM.ORD.ERROR.FILE(0),      <----- CUSTOMIZE
/*          UNIT=&PERMDA. ,                          <----- CUSTOMIZE
/*          DISP=(NEW,CATLG,DELETE) ,
/*          DCB=(RECFM=VB,LRECL=3200,BLKSIZE=32760,DSORG=PS) ,
/*          VOL=SER=&DVOL. ,
/*          SPACE=(TRK,(10,10))
/*
/******
/* THE SYSIN DD STATEMENT IS USED TO INPUT THE DMLoad
/* CONTROL STATEMENTS.
/******
/*
//SYSIN DD DDNAME=SYSIN
// PEND
/*
//DMLoad EXEC CAKSLOAD
//STEP1.SYSIN DD *
  INPUT JARS = CAIKSJR
  OUTRECS   = MBJ

```

Sample output generated by this jobstream appears in the section Daily Processing Output.

How JCL DD Statements Relate to Control Statements

File Description	These CAKSLOAD Control Statements	Relate to JCL DDNAME	With These Required DCB Attributes
Input Data File	INPUT internal-ddname= JCL-ddname	ddnames (no defaults)	
Output Data File	OUTPUT=ddname OUTPUT=CAIKSOP OUTPUT omitted OUTREC uses this OUTPUT data set.	ddname CAIKSOP (default) CAIKSOP (default)	RECFM=VB LRECL=32000 BLKSIZE=32760 DSORG=PS
Recycle Output	RECYCLE OUTPUT=ddname RECYCLE OUTPUT=CAIKSRO RECYCLE OUTPUT	ddname CAIKSRO (default CAIKSRO (default) OUTPUT CAIKSOP	RECFM=VB LRECL=32000 BLKSIZE=32760 DSORG=PS
Corrected Error File	RECYCLE	ddname CAIKSRI	RECFM=VB LRECL=32000

File Description	These CAKSLOAD Control Statements	Relate to JCL DDNAME	With These Required DCB Attributes
	INPUT=ddname RECYCLE INPUT=CAIKSRI RECYCLE INPUT	CAIKSRI	BLKSIZE=32760 DSORG=PS

ERRORS= and LINES= aren't related to specific data sets.

The CA\$KREX User Exit for CAKSLOAD

This user exit provides a means of manipulating output data records before they are written to disk. Therefore, this exit point can modify the construct.

The following information describes the detail linkage conventions for interfacing to DataManager's user exit.

- This user exit should be written in Assembler Language.
- The user exit uses standard IBM linkage conventions.
- The exit routine, CA\$KREX, must reside in a LNKLST library or in the library in which DataManager resides, as indicated by the STEPLIB DD statement, or in a library concatenated to the STEPLIB DD statement.
- It is not necessary to link edit an exit routine with any part of DataManager. The exit routine is compiled and linked independently of DataManager. DataManager uses a *late binding* technique of exit name specification.
- Every call to any exit point by DataManager is identical, except for EOF on input. That is, there is no *first time* flag or signal to the exit.
- Please note that this exit doesn't have to be reentrant (RENT) or reusable (REUS).
- The name of the exit **must** be CA\$KREX.

A sample user exit is found on the following page.

```

CA$KREX  CSECT
*****
*
*          CA$KREX  -  DUMMY EXIT ROUTINE FOR CONSTRUCT ROUTINE
*
*  THIS ROUTINE SHOULD BE REPLACED BY THE USER IF HE NEEDS
*  AN EXIT ROUTINE. IT MUST FOLLOW STANDARD IBM LINKAGE CONVENTIONS.
*  THIS ROUTINE TAKES TWO PARAMETERS.
*  1) - POINTER TO THE OUTPUT BUFFER AFTER THE RDW (4 BYTES)
*  2) - POINTER TO THE AREA WHERE THE CONSTRUCT SHOULD BE
*
*  THIS DUMMY ROUTINE JUST RETURNS BACK WITH ZERO.
*
*****
R1      EQU    1
R2      EQU    2
R3      EQU    3
R4      EQU    4
R5      EQU    5
R6      EQU    6
R7      EQU    7
R8      EQU    8
R9      EQU    9
    
```

```
R10 EQU 10
R11 EQU 11
R12 EQU 12
R13 EQU 13
R14 EQU 14
R15 EQU 15
      USING *,R15          ESTAB. BASE REG.
      STM R14,R12,12(R13)  SAVE CALLERS REGS.
      LM R8,R9,0(R1)      LOAD REGS. WITH CALLERS PARM LIST
*      REG 8 CONTAINS ADDRESS OF ORDBUF
*      REG 9 CONTAINS ADDRESS OF CONSTRUCT PTR
*
      LM R14,R12,12(R13)  RESTORE CALLERS REGS.
      SLR R15,R15         RETURN CODE IS ZERO
      BR R14             RETURN TO RPG FROM EXIT
SAVEAREA DC 18F'0'
      END
```

Daily Processing Output

When DataManager successfully processes the input data, you'll receive printed output like this:

```

COMPANY NAME                DATAMANAGER LOAD PROCESSING                PAGE 1
CA PMA/DM 1.0 9010KS100                02 OCT 1990 14.00.07

*-----CONTROL STATEMENT LISTING-----*
      STATEMENT *-----CONTROL STATEMENTS-----*
      NUMBER   *.../...1.../...2.../...3.../...4.../...5.../...6.../...7.../...8*
      001     * INPUT JARS      = CAIKSJR                *
      002     * OUTRECS        = MBJ                    *
A      003     * RECYCLE OUTPUT                                *
      004     * ERRORS          = 20                      *
      *.../...1.../...2.../...3.../...4.../...5.../...6.../...7.../...8*

*-----CONTROL STATEMENT ERROR MESSAGES-----*
      STATEMENT MESSAGE
      NUMBER     CODE *-----MESSAGE TEXT-----*
B
*-----DEFINITIONS DATABASE LOAD ERROR MESSAGES-----*
      STATEMENT MESSAGE
      NUMBER     CODE *-----MESSAGE TEXT-----*
C
COMPANY NAME                DATAMANAGER LOAD PROCESSING                PAGE 2
CA PMA/DM 1.0 9010KS100                02 OCT 1990 14.00.07

CAKS100I NORMAL TERMINATION.
COMPANY NAME                DATAMANAGER LOAD PROCESSING                PAGE 3
CA PMA/DM 1.0 9010KS100                02 OCT 1990 14.00.07

*-----INPUT STATISTICS-----*
      DATASET          DDNAME          RECORDS          IRDID          RECORDS
                        READ              GENERATED
      JARS              CAIKSJR          544              MBJ            213
                        -----
                        544              213
      ** TOTALS **          =====
                        544              213

*-----OUTPUT STATISTICS-----*
                        DDNAME  ORDID          RECORDS
                        CAIKSOP MBJ            WRITTEN
                        -----
                        213
                        213

*-----RECYCLE STATISTICS-----*
      INPUT          INPUT          OUTPUT          OUTPUT
      DDNAME         RECORDS         DDNAME         RECORDS
                        CAIKSRO          0
  
```

CONTROL STATEMENT LISTING

lists the control statements DataManager processed while running this job.

CONTROL STATEMENT ERROR MESSAGES

explain errors detected within CAKSLOAD control statements.

DEFINITION DATABASE LOAD ERROR MESSAGES

explain errors detected in input record definitions.

Messages

should include a **CAKS100I NORMAL TERMINATION** message that verifies that the job ran successfully.

DATASET

shows the values to the left of the equal sign on INPUT control statements. These are internal ddnames used exclusively by DataManager.

DDNAME

specified the JCL ddname associated with this data set. These values appear to the right of the equal sign in INPUT control statements.

RECORDS READ

shows the number of input records this data set contains.

IRDID

lists the IRD record types selected for generating output.

RECORDS GENERATED

tells the number of records generated from this input.

DDNAME

reports the ddname of the data set where these output records were written.

ORDID

lists the ORD types DataManager generated as output.

RECORDS WRITTEN

tells the number of records written to this data set.

INPUT DDNAME

gives the ddname of the data set containing corrected errors processed during this run.

INPUT RECORDS

tells the number of corrections processed.

OUTPUT DDNAME

specifies the ddname of the data set where errors detected during this run were written.

OUTPUT RECORDS

tells the number of bad input records written to the error data set.

The CA Earl Print Job

The CAKSORDS member in CAI.SAMPJCL executes the CA Earl program to generate reports on the output data file generated from the Daily job, CAKSLOAD. This PROC uses two CAI.CAIMAC members. The first contains the CA Earl record definitions (DEF statements). The second member contains CA Earl source statements needed to produce the report.

Before running the CA Earl program, complete the following steps:

- Customize the CAKSEARL PROC. Be sure to change the SSID to reflect the correct database system identifier.
- Create a CAI.CAIMAC member using the sequential CAIKSERL generated by CAKSCOMT (i.e., ORDEF1).
- CAI.CAIMAC members CAKSORDS1 and CAKSORDS2 contain sample CA Earl source statements for two sample reports. Copy one of these members to a new CAI.CAIMAC member (i.e. DEF1PRT).
- Modify the member created in step3 (DEF1PRT) as follows:
 - Change the COPY CBDEF3 statement to reflect the CAI.CAIMAC member name for the CA Earl record definitions (DEF statements) from step 2. For this example, it would be COPY ORDEF1.
 - Change the Report Title statements.
 - Modify the CONTROL statements.
 - Modify the PRINT statements.
- Modify the CAKSORDS member from CAI.SAMPJCL before executing the report. Change the //SYSIN DD statement to reflect the correct report control statement member name (created in step 3). For this example, it would be //SYSIN DD CAI.CAIMAC(DEF1PRT).

Note: See the *CA Earl User Guide* for details on the CA Earl statement.

JCL for Running CA Earl Reports

The JCL contains numbered instructions that tell you what to do.

```
//CAKSORDS JOB (ACCTINFO), 'PMGR', CLASS=A, MSGCLASS=X, REGION=2000K
//*****
/* PURPOSE: THIS SAMPJCL WILL BE USED TO PRINT THE CA PMA/DM ORD
/*          DATA FILE.
/*
/* INSTRUCTIONS:
/* 1. THE CAKSEARL PROCEDURE INVOKED IN THIS JCL MEMBER MAY BE
/*    RUN INSTREAM OR FROM A SYSTEM OR USER PROCEDURE LIBRARY.
/* 2. CHANGE THE CAKSORD DD STATEMENT TO REFLECT THE CORRECT ORD
/*    DATA FILE DATA SET NAME.
/* 3. CHANGE THE HIGH-LEVEL QUALIFIER OF THE SYSIN DD STATEMENT
/*    TO REFLECT THE CORRECT MACLIB.
/* 4. CHANGE THE JOB CARD TO REFLECT YOUR INSTALLATION STANDARDS.
/* 5. RUN THE JOB.
//*****
/*
//EARL      EXEC CAKSEARL
//SYSEARL   DD SYSOUT=*
//CAKSORD   DD DISP=SHR, DSN=&INDEX..DM.ORD.DATA.FILE <--- CUSTOMIZE
//SYSIN     DD DSN=&INDEX..CAJREARL(CAKSORD1), DISP=SHR
/*SYSIN    DD DSN=&INDEX..CAJREARL(CAKSORD2), DISP=SHR
/*
```

Sample output generated by this jobstream appears below.

CA Earl Output

When DataManager successfully produces a report, you'll receive printed output like this:

15/02/91		ORD REPORT EXAMPLE 1				PAGE	1
ORD RECORDS							
BY RUN DATE							
MBJ_RUN_DATE	MBJ_START_TIME	MBJ_JOBNAME	MBJ_JOB_NUMBER	MBJ_CLASS	MBJ_STOP_TIME	MBJ_CPU_TIME	
19850526	1703140000	ACSSPC01	*****	C	1338000000	166.32000	
19850526							
19850528	1000580000	WENDYM	*****	A	1003260000	6.69600	
19850528	1000070000	SMFDMP	*****		1003420000	15.40800	
19850528	0954110000	FKMANGLE	*****	B	1001340000	31.71600	
19850528	1053340000	QARICHF	*****	B	1101480000	41.50800	
19850528	1047210000	QARICHE	*****	T	1051220000	9.03600	
19850528	1045480000	CPXLNK1	*****	B	1046320000	0.82800	
19850528	1044130000	TWSHRLYO	*****	A	1044260000	0.72000	
19850528	1042380000	CPXC0B1	*****	B	1044140000	26.96400	
19850528	1042340000	QARICHD	*****	B	1042500000	0.64800	
19850528	1019520000	CPXJDLNK	*****	B	1025270000	16.20000	
19850528	1017160000	WENDYM	*****	A	1020080000	7.38000	
19850528	1010430000	DBC1201	*****	}	1121170000	91.11600	
19850528	1009060000	QARICHZ	*****	T	1009340000	0.43200	
19850528	1006100000	QARICHZ	*****	T	1006510000	0.25200	
19850528	1004010000	QARICHI	*****	A	1004140000	0.21600	
19850528	1258450000	ROBTC	*****	B	1259260000	0.25200	
19850528	1257530000	QARICHL	*****	A	1258000000	0.36000	
19850528	1257010000	ROBTB	*****	B	1257160000	0.03600	
19850528	1255460000	QARICHC	*****	B	1256240000	2.30400	
19850528	1255010000	TWSHRLYO	*****	A	1255060000	0.25200	
19850528	1254170000	SCOTTFA	*****	A	1255350000	5.72400	
19850528	1253390000	QARICHA	*****	A	1254110000	1.58400	
19850528	1250500000	NORMANX	*****	B	1251060000	0.79200	
19850528	1250400000	SCOTTFA	*****	A	1251590000	4.75200	
19850528	1247190000	TAPECPY2	*****		1258520000	6.33600	
19850528	1246170000	SCOTTFA	*****	A	1246410000	1.51200	
19850528	1244370000	QARICHA	*****	A	1245200000	1.33200	
19850528	1244270000	SCOTTFA	*****	A	1244510000	1.54800	
19850528	1244230000	QARICHC	*****	B	1245150000	1.36800	
19850528	1241430000	SCOTTFA	*****	A	1242150000	1.33200	
19850528	1238080000	SCOTTFA	*****	A	1238250000	0.64800	
19850528	1235240000	NORMANB	*****	B	1235320000	0.39600	
19850528	1234550000	TWSHRLYP	*****	A	1235250000	1.08000	
19850528	1228230000	CICSUV16	*****	}	1228280000	0.21600	
19850528	1228090000	DBC1201	*****	}	1238060000	81.82800	
19850528	1226050000	QARICHI	*****	A	1226080000	0.14400	
19850528	1222170000	WENDYM	*****	A	1242010000	43.81200	
19850528	1213100000	QARICHK	*****	A	1213120000	0.21600	
19850528	1205270000	WENDYM	*****	A	1220010000	19.18800	
19850528	1202550000	NORMANA	*****	B	1203070000	0.43200	
19850528	1158390000	QARICHL	*****	A	1158430000	0.36000	
19850528	1157140000	CPXJDSYX	*****	B	1200360000	9.86400	
19850528	1153280000	CPXJDSYN	*****	B	1158290000	9.64800	
19850528	1150030000	CPXC0B1	*****	B	1152130000	27.25200	
19850528	1148390000	NORMANZ	*****	B	1148460000	1.00800	
19850528	1143040000	WENDYM	*****	A	1155110000	19.11600	
19850528	1141580000	QARICHA	*****	A	1142260000	1.58400	

MBJ_RUN_DATE

Tells you the day these records relate to.

MBJ_CPU_TIME

Is computed from MBJ_START_TIME and MBJ_STOP_TIME.

Note: You can modify this report layout by specifying different CA Earl control statements. See the *CA Earl User Guide* for details.

Chapter 7: DataManager Security and Audit

Security for DataManager relies upon CA Top Secret[®], CA ACF2[®], or RACF external security package. Security for all DataManager components must be defined with one of the above packages.

The security administrator is responsible for defining and implementing all security in DataManager. Users cannot implement security from DataManager.

This chapter provides system administrators with information for setting up security for CA Top Secret, CA ACF2, or RACF. Refer to the section that applies to the security used by your installation.

CA Top Secret Security

Classes used by DataManager must be defined to CA Top Secret. This allows CA Top Secret to process security calls from DataManager.

New classes are defined to CA Top Secret by adding them to the Resource Definition Table (RDT) via the TSS command. Once added, they are immediately accessible. No restart, reinitialization, or IPL is required.

The new classes and their associated access levels for DataManager are:

DataManager Component	Security class	Access Levels
Dialog	ACDIALOG	READ and WRITE
Panel	ACPANEL	READ and WRITE
SQL	ACSQL	READ and WRITE

Note: Tables, views, indexes, etc., are controlled by the database security. If you **do** have a security package that controls database objects, you must set up security according to the rules of the security package.

You can list your current RDT via the TSS LIST(RDT) command to verify that these classes are not already defined. If they are defined, you may proceed with protecting and permitting these new resources.

To add these classes, you must select eight unused resource codes. These codes must be in the hexadecimal range from 01 to 3F.

The following sample commands show the exact TSS command syntax for defining these new classes. In these examples, the resource codes of 38 through 3F have been selected.

To add resource class:

```
ACDIALOG    TSS ADDTO(RDT) RESCLASS(ACDIALOG) RESCODE(3A) -
             ACLST(READ=20,WRITE=40,ALL,NONE) -
             ATTR(LONG) DEFACC(READ=20)
ACPANEL     TSS ADDTO(RDT) RESCLASS(ACPANEL) RESCODE(3D) -
             ACLST(READ=20,WRITE=40,ALL,NONE) -
             ATTR(LONG) DEFACC(READ=20)
ACSQL       TSS ADDTO(RDT) RESCLASS(ACSQL) RESCODE(3F) -
             ACLST(READ=20,WRITE=40,ALL,NONE, ) -
             ATTR(LONG) DEFACC(READ=20)
```

CA ACF2 Security

Resource types used by DataManager must be defined to CA ACF2. This allows CA ACF2 to process security calls from DataManager.

The new resources and their associated DataManager components are:

DataManager Component	Resource
Dialog	ACD
Panel	ACP
SQL	ACS

Note: Tables, views, indexes, etc., are controlled by the database security. If you **do** have a security package that controls database objects, you must set up security according to the rules of the security package.

RACF Security

Classes used by DataManager must be defined to RACF. This allows RACF to process security calls from DataManager.

New classes are defined to RACF by adding them to the RACF resource list.

The new classes and their associated access levels for DataManager are:

DataManager Component	Security class	Access Levels
Dialog	ACDIALOG	READ and WRITE
Panel	ACPANEL	READ and WRITE
SQL	ACSQL	READ and WRITE

Note: Tables, views, indexes, etc., are controlled by the database security. If you **do** have a security package that controls database objects, you must set up security according to the rules of the security package.

Appendix A: DataManager Panel Displays

The following table summarizes the colors and intensities, by panel element, used by DataManager when displaying panels on nonprogrammable color and monochrome terminals.

Action Bar and Pull-Down

Panel Element	Color Terminal	Monochrome Terminal
Background	Black	Black
Choices	White	White
Mnemonics	Underscore	Underscore

Panel Body

Panel Element	Color Terminal	Monochrome Terminal
Background	Black	Black
Protected Information		
<ul style="list-style-type: none"> ■ Panel Titles ■ Panel ID ■ Instructions ■ Field Prompts ■ Brackets ■ Column Headings ■ Group Headings ■ Normal Text ■ Emphasized Text ■ Entry Field Underscore 	<ul style="list-style-type: none"> ■ Yellow ■ Blue ■ Turquoise ■ Turquoise ■ Turquoise ■ Turquoise ■ Turquoise ■ Turquoise ■ Yellow 	<ul style="list-style-type: none"> ■ High intensity ■ Normal intensity ■ Normal intensity ■ Normal intensity ■ Normal intensity ■ High intensity ■ Normal intensity ■ Normal intensity ■ High intensity
Normal Input	Green	Normal intensity
Emphasized Input	Yellow	High intensity

Panel Element	Color Terminal	Monochrome Terminal
Choices	White	Normal intensity
Unavailable Choices	Blue	Asterisk (*)
Mnemonics	Underscore	Underscore
Entry Field Content		
■ Normal Input	■ Green	■ Normal intensity
■ Emphasized Input	■ Yellow	■ High intensity
Scrolling Information	Blue	Normal intensity
Separator Line	Turquoise	Normal intensity
Pop-up Window Border	Turquoise	Normal intensity

Function Key Area

Panel Element	Color Terminal	Monochrome Terminal
Background	Black	Black
Choices	Blue	Normal

Selection Emphasis

Panel Element	Color Terminal	Monochrome Terminal
Selection Cursor		
■ Choices	■ Text Cursor	■ Text Cursor
■ Entry Field	■ Text Cursor	■ Text Cursor in field
Selected Emphasis	Yellow	Reverse color
Selected/Cursored	Yellow/Text Cursor	Reverse color

Error Emphasis

Panel Element	Color Terminal	Monochrome Terminal
Error Emphasis	Red	Reverse

Messages

Panel Element	Color Terminal	Monochrome Terminal
Notification		
■ Background	■ Black	■ Black
■ Foreground	■ White	■ High Intensity
Warning		
■ Background	■ Black	■ Black
■ Foreground	■ Yellow	■ High Intensity
Critical		
■ Background	■ Black	■ Reverse/Highlight
■ Foreground	■ Red	■ Reverse/Highlight

Appendix B: Predefined CA JARS History Records

Output from CA JARS Related Products and CA JARS Interfaces as Processed by JARS/OLF	JCL DDNAME	Internal DDNAME	IRD and ORD Name	EXTDATA Type	CAJRSQL Member
ADABAS	CAIKSJR	JARS	MAB	n/a	DBASES
CA Datacom/DB	CAIKSJR	JARS	MDB	n/a	DBASES
CA DYNAM/TLMS debits credits	CAIKSJR	JARS	MVD MVC	n/a n/a	TVA
CA IDMS/DB	CAIKSJR	JARS	MIB	n/a	DBASES
CA MAZDAMON debits credits	CAIKSJR	JARS	MND MNC	n/a n/a	NETVIEW
CA Roscoe	CAIKSJR	JARS	MRB	n/a	Roscoe
CA 1 debits credits	CAIKSJR	JARS	MVD MVC	n/a n/a	TVA
CICS programs transactions	CAIKSJR	JARS	MCP MCT	n/a n/a	MVSCICS
DB2 debits credits	CAIKSJR	JARS	M2D M2C	n/a n/a	DBASES
CA JARS/DSA debits credits	CAIKSJR	JARS	MSD MSC	n/a n/a	JARSDSA
CA JARS/DSA 6.0 Direct Feed File	CAIKSJR	JARS	DSA	SDSA	JARSDSA
IMS	CAIKSJR	JARS	MMB	n/a	DBASES
MVS - Batch step job I/O print	CAIKSJR	JARS	MBS MBJ MBI MBP	n/a n/a n/a n/a	MVSBAT
debit credit			M-D M-C	n/a n/a	MVSDBCR
MVS RJE	CAIKSJR	JARS	MJB	n/a	MVSRJE
MVS TSO I/O job print step			MTI MTJ MTP MTS	n/a n/a n/a n/a	MVSTSO
NETVIEW debit credit			MND MNC	n/a n/a	NETVIEW
TVA debits credits	CAIKSJR	JARS	MVD MVC	n/a n/a	TVA
VAX system printing processing			X-S X-P X-J	n/a n/a n/a	VAX
VM Accounting	CAIKSJR	JARS	IEZ	IEZ	JARINT

VSE (converted from TOPS) BATCH step job I/O print	CAIKSJR	JARS	DBS DBJ DBI DBP	n/a n/a n/a n/a	VSEBAT
CICS program transaction	CAIKSJR	JARS	DCP DCT	n/a n/a	VSECICS
ICCF	CAIKSJR	JARS	DFB	n/a	VSEICCF
IDMS	CAIKSJR	JARS	DIB	n/a	VSEIDMS
POWER RJE	CAIKSJR	JARS	DJR	n/a	VSERJE
MVS Address Space Task	CAIKSJR	JARS	J30	S30	EXTTASK
Step			X30	S30X	EXTSTEP
Interval			I30	S30I	EXTINT
I/O Task			J10	S10	EXTTASK
Step			X10	S10X	EXTSTEP
Interval			I10	S10I	EXTINT
RJE BSC			BSC	SBSC	EXTRJE
RJE SNA			SNA	SSNA	EXTRJE
SYSOUT			S06	S06	EXTWTR
DB2			DB2	S101	EXTDB2
TSO COMMAND			S32	S32	EXTTSOC
Data in Virtual			S41	S41	EXTDIV
APPC Inbound Conversation			I33	S33I	EXTAPPC
Outbound Conversation			O33	S33O	EXTAPPC
Transaction			T33	S33T	EXTAPPC
JES2 Network Transmit	CAIKSJR	JARS	J57	S572	EXTNJE
SMS Dataset Internal			I42	S42I	EXTSMS
Dataset Close			D42	S42D	
Measured Usage					EXTMU
System-Wide			R89	R89	
Address Space Task			JMU	U30	
Step			XMU	U30X	
Interval			IMU	U30I	
OpenEdition					EXTOE
HFS File Usage			HFS	OHFS	
Address Space Task			JOE	O30	
Step			XOE	O30X	
Interval			IOE	O30I	
TCP/IP					EXTTCP
TELNET			TEL	STEL	
SOCKET API			SOC	SAPI	
FTP			FTP	SFTP	
CMF (CICS Monitoring Facility) Tasks			CMF	CMCC	EXTCMF
EXTDATA CICS File	CAIKSJR	JARS	CFL	CFIL	MVSECIC
EXTDATA CICS Root	CAIKSJR	JARS	CRT	CRT	
EXTDATA CICS Prog	CAIKSJR	JARS	CPR	CPRG	
EXTDATA CICS Term	CAIKSJR	JARS	CTE	CTRM	
WebMQ Accounting data	CAIKSJR	JARS	MQS	SMQA	EXTMQR
WebMQ Queue Info	CAIKSJR	JARS	MQQ	SMQQ	EXTMQQ
WebMQ Task Data	CAIKSJR	JARS	MQR	SMQR	EXTMQR
WebSphere					
WebSphere Server	CAIKSJR	JARS	WSA	SWSA	EXTWSA
WebSphere WebContainer			WWA	SWWA	
TCP/IP 119					
Telnet Termination	CAIKSJR	JARS	TCT	STCT	EXT119
FTP Client Completion			CTC	SCTC	
Sockets			UDP	SUDP	
TN3270 Server SNA			SST	SSST	
Telnet Client term			TCC	STCC	
FTP Server Completion			FST	SFST	
JARS Interface Data					

ADABAS Activity Summary	CAIKSJR	JARS	IEA	SIEA	JARINT
Datacom Activity Summary	CAIKSJR	JARS	IED	SIED	JARINT
IMS LOGDATA Accounting	CAIKSJR	JARS	IEI	SIEI	JARINT
NetView Session Summary	CAIKSJR	JARS	IEN	SIEN	JARINT
Roscoe Session Summary	CAIKSJR	JARS	IER	SIER	JARINT
Tape Volume Activity	CAIKSJR	JARS	IET	SIET	JARINT
VM Session Summary	CAIKSJR	JARS	IEZ	SIEZ	JARINT

Appendix C: DataManager Tables

IRDDESC Table

This table is maintained by the Input Record Descriptions panel. It stores records for both the DEVELOPMENT and REAL versions. VERSION and IRDID values uniquely identify each record in this table.

Note that * in the Key column identifies fields used to select specific records.

Key	Field Name	Type	Length
*	VERSION	CHAR	4
	DATASET	CHAR	7
*	IRDID	CHAR	8
	DESCRIPT	CHAR	20
	ORIGIN	CHAR	1
	IDBEGPOS	CHAR	5
	IDLENGTH	CHAR	2
	IDHEXVAL	CHAR	20
	LENGTH	CHAR	5

IRDTAB Table

This table is maintained by the Input Record Definition panel. It stores records for every input field in the DEVELOPMENT and REAL versions. Every IRDID value in this table must also be defined as a record in the IRDDESC table. VERSION, IRDID and ELEMENT values identify each record in this table.

Note that * in the Key column identifies fields used to select specific records.

Key	Field Name	Type	Length
*	VERSION	CHAR	4
	DATASET	CHAR	7
*	IRDID	CHAR	8
*	ELEMENT	CHAR	16
	FORMAT	CHAR	2
	ATTRIB	CHAR	2
	BEGINPOS	CHAR	5
	LENGTH	CHAR	2
	PREC	CHAR	2
	DESCRIPT	CHAR	20

OPTTAB Table

This table is maintained jointly by the Options panels of DataManager and CA PMA Chargeback. It stores default settings for DataManager and CA PMA Chargeback sessions.

Note that * in the Key column identifies fields used to select specific records.

Key	Field Name	Type	Length
*	USERID	CHAR	8
	MONIC	CHAR	3
	ACTBAR	CHAR	5
	MSGWRN	CHAR	3
	MSGINF	CHAR	3
	SOD	CHAR	4
	ALTPF	CHAR	3
	DBROWS	CHAR	6
	BASEVER	CHAR	4
	CBVER*	CHAR	4

* identifies fields maintained only by CA PMA Chargeback.

ORDESC Table

This table is maintained by the Output Record Descriptions panel. It stores records for the DEVELOPMENT, TEST and PROD versions. VERSION and ORDID valued identify each record in this table.

Note that * in the Key column identifies fields used to select specific records.

Key	Field Name	Type	Length
*	VERSION	CHAR	4
*	ORDID	CHAR	3
	DESCRIPT	CHAR	20
	LENGTH	CHAR	5
	FLAGS	CHAR	1
	RETAIN	CHAR	4

ORDTAB Table

This table is maintained by the Output Record Definition panel. It stores records for every output field in the DEVELOPMENT, TEST and PROD versions. VERSION, ORDID and ELEMENT values identify each record in this table.

Note that * in the Key column identifies fields used to select specific records.

Key	Field Name	Type	Length
*	VERSION	CHAR	4
*	ORDID	CHAR	3
*	ELEMENT	CHAR	16

TYPE	CHAR	1
FORMAT	CHAR	1
BEGINPOS	CHAR	5
LENGTH	CHAR	2
PREC	CHAR	2
SRCNAME1	CHAR	16
SRCNAME2	CHAR	16
DESCRIPT	CHAR	20
CONSTRUC	CHAR	8
FLAGS	CHAR	2
SRCIRDID	CHAR	8

Appendix D: Relationship Between IRD and ORD Formats

Format choices for IRDs and ORDs are different. These charts show you which output format is compatible with any given input format. They show that an IRD field's format and attribute determine what format its ORD field has. For example, if an IRD field has format B with attribute M, the output field must have format D.

Here is the key to the format of IRD fields (the value that appears under Format in the tables below).

- B**
binary
- C**
character
- F**
flag or bit string
- H**
hexadecimal numeric
- N**
character numeric
- P**
packed numeric
- X**
hexadecimal

Here is the key to the format of dates and times (the value that appears under Attribute in the tables below).

M

mmddy (American)

D

ddmmy (European)

J

yyddd (Julian)

Y

yymmdd (normalized full)

H

time in hours

N

time in minutes

S

time in seconds

T

time as hhmmss

DC

ddmmyyyy (European)

MC

mmddyyyy (American)

YC

yyyymmdd (normalized part)

JC

yyyddd (Julian)

Note: The length and precision of formats **D**, **R**, and **T** are fixed as described above and **cannot** be changed.

Here is the key to the format of Output Record Definition fields.

C

character, length=ANY

D

duration, length=8, precision=0

N

packed decimal, length=ANY, precision=ANY

R

packed unsigned, length=8, precision=5

T

time, length=10, precision=4 (HHMMSSTTTT)

B Format Input Record Definition

Format	Attribute	Length	Precision	Example	Output Record Definition Format
B		1-4	ANY		N
B	D	3	0	DDMMYY	D
B	M	3	0	MMDDYY	D
B	Y	3	0	YYMMDD	D
B	J	3	0	YYDDD	D
B	DC	4	0	DDMMYYYY	D
B	MC	4	0	MMDDYYYY	D
B	YC	4	0	YYYYMMDD	D
B	JC	4	0	YYYYDDD	D
B	H	1-4	ANY	HHHH	R,T
B	N	1-4	ANY	MMMM	R,T
B	S	1-4	ANY	SSSS	R,T
B	T	3,4	ANY	HHMMSS	R,T

C, F, and H Formats Input Record Definition

Format	Attribute	Length	Precision	Example	Output Record Definition Format
C		ANY	0		C
C	D	8	0	DD/MM/YY	D
C	M	8	0	MM/DD/YY	D
C	Y	8	0	YY/MM/DD	D
C	DC	10	0	DD/MM/YYYY	D
C	MC	10	0	MM/DD/YYYY	D
C	YC	10	0	YYYY/MM/DD	D
C	T	8	0	HH:MM:SS	R,T
F		1	0		C
H		ANY	ANY		N
H	D	3	0	DDMMYY	D
H	M	3	0	MMDDYY	D
H	Y	3	0	YYMMDD	D
H	J	3	0	YYDDD	D
H	DC	4	0	DDMMYYYY	D
H	MC	4	0	MMDDYYYY	D
H	YC	4	0	YYYYMMDD	D
H	JC	4	0	YYYYDDD	D
H	H	ANY	ANY	HHHH	R,T
H	N	ANY	ANY	MMMM	R,T
H	S	ANY	ANY	SSSS	R,T
H	T	>2	ANY	HHMMSS	R,T

N Format Input Record Definition

Format	Attribute	Length	Precision	Example	Output Record Definition Format
N		ANY	ANY		N
N	D	6	0	DDMMYY	D
N	M	6	0	MMDDYY	D
N	Y	6	0	YYMMDD	D
N	J	5	0	YYDDD	D
N	DC	8	0	DDMMYYYY	D
N	MC	8	0	MMDDYYYY	D
N	YC	8	0	YYYYMMDD	D
N	JC	7	0	YYYYDDD	D
N	H	ANY	ANY	HHHH	R,T
N	N	ANY	ANY	MMMM	R,T
N	S	ANY	ANY	SSSS	R,T
N	T	>5	ANY	HHMMSS	R,T

P and X Formats Input Record Definition

Format	Attribute	Length	Precision	Example	Output Record Definition Format
P		ANY	ANY		N
P	M	4	0	MMDDYY	D
P	D	4	0	DDMMYY	D
P	J	3	0	YYDDD	D
P	Y	4	4	YYMMDD	D
P	YC	5	0	YYYYMMDD	D
P	H	ANY	ANY	HHHH	R,T

Format	Attribute	Length	Precision	Example	Output Record Definition Format
P	N	ANY	ANY	MMMM	R,T
P	S	ANY	ANY	SSSS	R,T
P	T	>3	ANY	HHMMSS	R,T
X		ANY	0		C,R,T

Glossary

action

One of the keywords within an action bar. To perform an action, tab to a keyword within the action bar and press Enter.

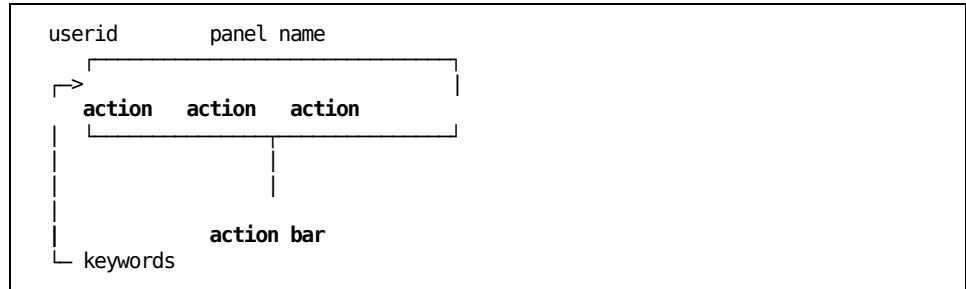

action bar

Appears at the top of a panel; it gives you access to a list of actions that DataManager panels support. Press F10 to activate the action bar. Then tab to the keyword of your choice and press Enter. When you make a selection, a pull-down appears that lists available options.

action bar pull-down

An extension of the action bar that displays a list of options available for the selected action bar choice. The pull-down appears after you make an action bar selection.

Advantage CA Earl

Easy Access Report Language. The report writer used by DataManager and CA PMA Chargeback.

application

A collection of software components that you purchase and install to perform specific types of work on a computer. In other words, the reason programs are written. For example, a payroll application or a chargeback application.

archive

The process of backing up tables in case they ever need to be restored.

batch processing

A method of processing large amounts of data at one time for jobs too large to execute immediately online. Such jobs don't involve user interaction.

cancel

An action that erases the current panel without processing it and returns you to the previous panel.

CA PMA/CB

An abbreviation for CA PMA Chargeback, an application that creates invoices that charge for usage of computer resources. See **chargeback**.

CA PMA/DM

An abbreviation for DataManager, the common database system used by all CA PMA applications.

chargeback

The process of measuring, recording, charging for, and reporting resource usage by cost center.

column

A vertical list of values in a table that correspond to one field. Not a *row*.

	Column 1	Column 2	Column 3
	CITY	STATE	ZIPCODE
Row 1	Boston	MA	02120
Row 2	New York	NY	10016
Row 3	Dallas	TX	75217
Row 4	Phoenix	AZ	85012
Row 5	Chicago	IL	60640

command input area

The area that follows the ==> indicator on an online data entry panel. Used to enter commands, link, transfers, prompts.

Command ==>	_____
F1=Help	F3=Exit F4=Prompt

commit processing

A batch job that validates all CA PMA definitions to ensure they are present in the source IRD or ORD and

- freezes all of the associated CA PMA product's DEVELOPMENT version records.
- deletes any CA PMA committed records for a specified CA PMA product and version.
- changes the version of the CA PMA product's DEVELOPMENT definitions to a user-specified version.

construct

An identifier that DataManager adds to each output record. Each PMA application uses records that have a different construct.

control statement

A list of keywords that determine what a batch job will do. Defaults are usually defined during installation.

database

A systemized collection of data stored for immediate access. See also **relational database**.

Database Administrator (DBA)

A person who is responsible for a database system, particularly for defining how data can be accessed and stored. The DBA is also usually responsible for database integrity, security, performance, and recovery.

database archival

Periodic backups of the database as protection against media failure or for future reference.

database load

Transferring data to the database for processing.

data dictionary

A definition of the database files and fields and their attributes.

data set

A group of logically related records stored together and given a unique name.

delimiter

A special character that shows where a character string starts and ends.

DEVELOPMENT version

The version you can edit. These records haven't been committed yet. See **commit processing**.

diagnostic message

A message displayed and/or printed by DataManager when it detects an error during execution.

enter

A keystroke that:

- submits panel information to the computer for processing
- tells the computer to perform selected actions on specific objects
- implies selection of an item

entry panel

A specific panel type containing one or more entry fields (and optionally, selection fields and protected information such as headings, prompts, and explanatory text).

exit

An action that terminates the current panel and returns you to a higher level panel. Repeated exit requests return to the highest level in the panel hierarchy.

fast path

A shortcut for displaying specific panels. This technique uses the first letter of keyword choices to specify a panel destination. For example, **type** IC displays Committed Input definitions because it selects Input from the first action bar, and Commit from the pull-down.

field

What input and output records consist of. The definition of data values aligned in a column within a table. This table contains elements named CITY, STATE, and ZIPCODE.

	Column 1	Column 2	Column 3
Fields -->	CITY	STATE	ZIPCODE
Row 1	Boston	MA	02120
Row 2	New York	NY	10016
Row 3	Dallas	TX	75217
Row 4	Phoenix	AZ	85012
Row 5	Chicago	IL	60640
Row 6	Las Vegas	NV	
Row 7	Seattle	WA	

function key

A key that causes a specified sequence of operations to be performed when it is pressed. Function keys are usually labelled **Fn**.

Command ==> _____ F1=Help F3=Exit F4=Prompt F9=Command

generic selection

Allows you to display, list or analyze a group of records, tables, or jobs whose names begin with the same characters by coding the common characters with a special character (%).

input ID

The unique code that occurs in the same place on all records of the same type.

input record definition

A list of the fields within an input record and their characteristics (offset, length, data format, precision, etc.).

installation option

A value specified on the installation macro when the product is installed.

internal-ddname

The seven-character name you define online via the Input Record Description panel.

```

userid          DataManager
-- Input  Output oPtions Exit Help
+- DMIDESD -Input Record Description
| Panel  Exit  Help
|-----|
| Enter Input Record Description
|
| > DD Name . . . . . JARS
|   IRD Name . . . . . MBJ

```

IRD

An acronym for Input Record Definition.

JCL-ddname

The ddname at the beginning of a JCL DD statement. For example,

```
//ddname DD DSN=...
```

keyword

Choices within the action bar. Tab to a keyword and press Enter to perform that particular action.

```

userid          panel name
--->
  action1 action2 action3
┌
└
  keywords

```

offset

Where the first character in a field is located within the record (the nth character position relative to 1). In the diagram below, the offset for Field B is 7.

```

1 2 3 4 5 6 7 <----- offset
|1 2 3 4 5 6|1 2 3 4 5 6 7 8 9|
| Field A | Field B |

```

online

Run from a computer terminal. An interactive computer session. As opposed to *batch* and *offline*.

output record definition

A list of the fields within an output record and their characteristics (length, data format, precision, etc.).

ORD

An acronym for Output Record Definition.

output record header

Since DataManager outputs records for Performance Management and Accounting applications, duration of services is of primary importance. For this reason, every output record definition includes a header that specifies a start stamp, stop stamp and duration.

panel ID

A set of numbers and letters which identify a product panel.

PMA

An acronym meaning Performance Management and Accounting.

precision

The number of digits to the right of the decimal point.

primary panel

The first panel that appears when you run DataManager.

PROD version

The data used to produce real invoices. As opposed to *TEST version* or *DEVELOPMENT version*.

prompt

1. A word on a screen that reminds you to supply a value. A field's label. 2. A DataManager feature that displays a list of values you can choose from. F4 (the Prompt key) works for any field that has a finite number of possibilities. For example, you can list existing ORD names and pick one. To display a field's Prompt list, tab to that field and press F4. To select a value from a Prompt list, tab to your choice and press Enter.

pull-down

Extensions of the action bar that display lists of options. Each keyword in an action bar has its own pull-down. The Exit pull-down lists three options.

```
userid
  Panel  Help  Exit
  -----
  |      Exit
  |      -
  |      1. Save and exit
  |      2. Exit without saving
  |      3. Resume
  -----
```

REAL version

The input definitions DataManager uses for its daily production processing.

record

A group of logically related data values treated as a unit.

relational database

A database that is organized and accessed according to relationships between data items. These relationships are expressed by means of table names and column (field) names. Data items are accessed by matching values and not by following predefined paths. This allows a high degree of data independence.

row

A horizontal line of values in a table that correspond to one data record. Not a *column*.

	Column 1	Column 2	Column 3
	CITY	STATE	ZIPCODE
Row 1	Boston	MA	02120
Row 2	New York	NY	10016
Row 3	Dallas	TX	75217
Row 4	Phoenix	AZ	85012
Row 5	Chicago	IL	60640

scroll bar

A line on some DataManager panels which gives you several ways to scroll records. For an explanation of how the scroll bar works, see Scrolling Lists.

```

DataManager  mm/dd/yy hh:mm:ss
Output      oPtions  Exit    Help

Input Descriptions List _____
_____
description name. Then Enter.

> More: - + ____ Row 0001 of 0062

```

SMF

The acronym for IBM's System Management Facilities. You can adapt DataManager to process SMF data using customization.

source record

The record of origin. The record where data values originate.

start and stop stamps

The date and time fields stored on the IRD. This information specifies when the process described by this record began and ended.

suspend

Stops processing a panel but leaves it on the terminal screen for easy reference. Then resumes running the preceding panel.

table

Two-dimensional arrays of rows and columns where data are stored. Each row stores a separate record. Each column has a name (like City or State).

TEST version

A separate set of definitions that allow you to experiment with DataManager without impacting your daily production processing.

version

DataManager can store two different versions of input definitions (DEVELOPMENT and REAL) and three different versions of output definitions (DEVELOPMENT, TEST and PROD). The DEVELOPMENT version is the one you edit. The other versions store committed records that can be used in production.

Index

%

% (wildcard search character) • 25

?

? command • 27

=

= command • 27

A

About window (genlevel) • 37, 117

action bar

 defined • 26, 31

 pull-down • 30

archiving tables • 136

Are You Sure window • 36, 58

arithmetic symbols (syntax diagrams) • 41

B

backing up • 138

BACKUP control statement • 138

batch jobs

 archive (CAKSARCH) • 136

 CA Earl reports (CAKSORDS) • 173

 commit • 146

 conversion • 155

 copy • 151

 production (CAKSLOAD) • 157

 restore (CAKSREST) • 142

Browse Committed

 IRDs (DMICOMP) • 62

 ORDs (DMOCOMP) • 96

C

CA ACF2 • 178

CA Earl • 10, 174

 print job • 174

 service • 10

CA LMP component • 11

CA Netman • 155

CA SRAM component • 12

CA Top Secret • 177

CA\$KREX user exit • 169

CAIKSERL DD Statement • 148

CAIKSPAR file • 134

CAIRIM component • 11

CAISSF component • 12

CAIVPE component • 13

CAKSARCH job (archive) • 136

CAKSCOMT job (commit) • 146

CAKSCPY job (copy) • 151

CAKSLOAD job (production) • 157

CAKSNET8 • 155

CAKSNET9 • 155

CAKSORDS job (CA Earl) • 173

CAKSREST job (restore) • 142

CB-CONS field • 25

changing • 71, 73, 104, 106

 input records • 73

 output records • 106

 record • 71, 104

description • 104

length or description • 71

column, defined • 17

comma usage • 41, 157

command • 27, 41

 line • 27

 notation • 41

commit • 19, 23, 64, 98, 153

 impact on tables • 153

 Input Record Definitions (DMICOME) • 64

 Output Commit Definition (DMOCOME) • 98

 processing • 19, 23

COMMIT control statement • 146

construct • 19, 23, 25

 CB-CONS • 25

 defined • 19

 program • 23

continuation character (-) • 157

control statements • 138, 142, 146, 151, 157, 158, 161

 BACKUP • 138

 COMMIT • 146

 continuation character • 157

 COPY • 151

 ERRORS • 161

 INPUT • 158

 LINES • 161

 OUTPUT • 161

 RECYCLE INPUT • 161

RECYCLE OUTPUT • 161
RESTORE • 142
conversion, CA Netman data • 155
COPY control statement • 151
copying • 23, 151, 153
 purpose • 23
 versions • 151, 153

D

daily processing • 157
dash usage • 157
Data Has Not Been Saved window • 37
date formats • 65
default values (syntax diagrams) • 41
defining • 25, 65, 99
 input records • 65
 output records • 99
 records, rule • 25
definition facilities • 51, 58, 62, 64, 82, 86, 96, 98
 IRDDDESC table • 51, 62
 IRDTAB table • 58, 64
 ORDDDESC table • 82, 96
 ORDTAB table • 86, 98
deleting • 25, 36, 75, 108
 input • 75
 output • 108
 prompt • 36
 records, rule • 25
delimiters • 41
DEVELOPMENT version • 19, 23, 151
 committing • 23
 copying into it • 151
 defined • 19
display fields, identifying • 25
displaying • 27, 30, 35, 37, 117
 genlevel • 37, 117
 last command executed • 27
 prompts • 35
 pull-down • 30
DMICOME, Commit Input Record Definitions • 64
DMICOMP, Browse Committed IRDs • 62
DMIDESD, Input Record Description • 51
DMIDESE, Input Record Definition • 58
DMIDESL, Input Descriptions List • 56
DMIDESP, Input Record Description (brief) • 51
DMOCOMP, Browse Committed ORDs • 96
DMODESE, Output Record Definition • 86

DMODESF, Redefine window • 86
DMODESH, Output Record Header • 92
DMODESL, Output Descriptions List • 83
DMODESP, Output Record Description • 82
duration, defined • 19

E

editing • 51, 73, 81, 106
 input records • 51, 73
 output records • 81, 106
ERRORS control statement • 161
executing the last command again • 27
exit • 32, 120, 169
 from CAKSLOAD job (CA\$KREX) • 169
 from Help • 120
 pull-down • 32

F

F keys • 30, 39, 119
 for Help • 119
 global • 39
 local • 30, 39
fast path • 27
features • 9
field help • 123
fields • 17, 19, 25, 73, 106
 defined • 17, 19
 editing • 73, 106
 protected • 25
flow • 19, 39
 panel map • 39
 system flow • 19
formatting • 65, 190
 dates and times • 65
 records • 190
freezing definitions • 146, 153
function keys (see F keys) • 30

G

genlevel • 37, 117
global F keys • 39

H

header, output record • 19, 25, 92
 defined • 19
 DMODESH • 92
 rule • 25
Help facility • 115, 119, 120, 121, 123, 125, 127, 129, 131

- exiting Help • 120
- field Help • 123
- for action bar choices • 115
- function key settings • 119
- help for Help • 131
- Help pull-down • 115
- index • 129
- overview • 115
- panel Help • 121
- table of contents panel • 125
- topic • 127

help for Help panel • 131

I

- identifying • 25
 - input fields • 25
 - protected fields • 25
- Index Help panel • 129
- input • 19, 23, 25, 47, 49, 51, 56, 58, 65, 71, 73, 75, 161, 189
 - description, changing • 71
 - Descriptions List (DMIDESL) • 56
 - fields, identifying • 25
 - ID • 19, 25, 65
 - panel sequence • 47
 - pull-down • 49
 - Record Definition • 58, 189
- panel (DMIDESE) • 58
- table • 189
 - Record Description • 51, 189
- panel (DMIDESD, DMIDESP) • 51
- table • 189
 - records • 51, 65, 73, 75
- defining • 65
- deleting • 75
- editing • 51, 73
 - recycling • 161
 - user-defined • 23, 65
- INPUT control statement • 158
- internal ddname • 65
- IRD, defined • 19
- IRDDESC table • 51, 56, 71, 189
 - content • 189
 - listing • 56
 - maintenance • 51, 71
- IRDTAB table • 58, 189
 - content • 189
 - maintenance • 58

J

- JCL • 137, 144, 149, 152, 165, 174
 - CAKSARES member • 137
 - CAKSCOMT member • 149
 - CAKSCPY member • 152
 - CAKSLOAD member • 165
 - CAKSORDS member • 174
 - CAKSREST member • 144

K

- keywords (syntax diagrams) • 41

L

- LINES control statement • 161
- local F keys • 30, 39

M

- map of panels • 39
- message • 31, 111
 - line • 31
 - options • 111
- moving panels • 31

N

- naming conventions • 25
- Netman • 155

O

- offset • 38
- online component • 16, 17
- options table • 190
- OPTTAB table • 190
- ORD, defined • 19
- ORDDESC table • 82, 83, 104, 190
 - content • 190
 - listing • 83
 - maintenance • 82, 104
- ORDTAB table • 86, 190
 - content • 190
 - maintenance • 86
- output
 - Commit Definition (DMOCOME) • 98
 - description, changing • 104
 - Descriptions List (DMODESL) • 83
 - field CB-CONS • 25
 - panel sequence • 77
 - pull-down • 79
 - Record Definition • 86, 190

panel (DMODESE) • 86
table • 190
 Record Description • 82, 190
panel (DMODESP) • 82
table • 190
 Record Header • 19, 25, 92
defined • 19
panel (DMODESH) • 92
rule • 25
 records • 81, 99, 106, 108
defining • 99
deleting • 108
editing • 81, 106
 RECYCLE control statement • 161
OUTPUT control statement • 161

P

panel • 31, 39
 map • 39
 operations • 31
 pull-down • 31
panels • 49, 51, 56, 58, 62, 64, 79, 82, 83, 86,
 92, 96, 98, 111, 121, 123, 125, 127, 129, 131
 Browse Committed • 62, 96
IRDs (DMICOMP) • 62
ORDs (DMOCOMP) • 96
 Commit Input Record Definitions (DMICOME)
 • 64
 Help • 121, 123, 125, 127, 129, 131
help for Help • 131
help with a field • 123
help with a panel • 121
index • 129
table of contents • 125
topic panel • 127
 input • 49, 51, 56, 58
Descriptions List (DMIDESL) • 56
pull-down • 49
Record Definition (DMIDESE) • 58
Record Description (DMIDESD, DMIDESP) • 51
 output • 79, 82, 83, 86, 92, 98
Commit Definition (DMOCOME) • 98
Descriptions List (DMODESL) • 83
pull-down • 79
Record Definition (DMODESE) • 86
Record Description (DMODESP) • 82
Record Header (DMODESH) • 92
 Redefine window (DMODESF) • 86
 User Options • 111

parentheses usage • 41
pop-up windows • 34
primary Panel • 26
processing, daily • 157
PROD version • 19, 151
 copying • 151
 defined • 19
production • 23, 157
 environment • 23
 job (CAKSLOAD) • 157
prompt feature • 35
protected fields, identifying • 25
pull-downs • 30, 31, 32, 49, 79, 115
 displaying • 30
 exit • 32
 Help • 115
 input • 49
 output • 79
 panel • 31
punctuation marks (syntax diagrams) • 41

R

RACF • 179
REAL version • 19, 151
 copying • 151
 defined • 19
records • 179
RECYCLE • 161
 INPUT control statement • 161
 OUTPUT control statement • 161
Redefine window (DMODESF) • 38, 86
repeat symbol • 41
reports • 141, 145, 150, 153, 171
 CAKSARCH archive job • 141
 CAKSCOMT commit job • 150
 CAKSCPY copy job • 153
 CAKSLOAD processing • 171
 CAKSREST restore job • 145
RESTORE control statement • 142
restoring tables • 142
row, defined • 17

S

SAMPJCL • 137, 140, 144, 149, 152, 165, 173
 CAKSARCH archive job • 140
 CAKSARES job • 137
 CAKSCOMT commit job • 149
 CAKSCPY copy job • 152
 CAKSLOAD production job • 165

- CAKSORDS report job • 173
- CAKSREST restore job • 144
- saving records • 32, 37
- scrolling • 25, 33
- search strings • 25
- security • 177, 178, 179
 - CA ACF2 • 178
 - CA Top Secret • 177
 - overview • 177
 - RACF • 179
- SQL wildcard character • 25
- start stamp • 19
- stop stamp • 19
- suspend • 31
- syntax diagrams • 41
- system flow • 19, 23

T

- table maintenance • 47
- table of contents Help panel • 125
- tables • 17, 136, 138, 142, 189, 190
 - archiving • 136, 138
 - contents • 189
 - defined • 17
 - IRDDDESC • 189
 - IRDTAB • 189
 - OPTTAB • 190
 - ORDDESC • 190
 - ORDTAB • 190
 - restoring • 142
- TEST version • 19, 151
 - copying • 151
 - defined • 19
- time formats • 65
- topic Help panel • 127

U

- user • 111, 169
 - exit (CA\$KREX) • 169
 - Options (DMOPTNS) • 111

V

- validation • 16
- variables (syntax diagrams) • 41
- version • 19, 146, 151, 153
 - copying • 151, 153
 - defined • 19
 - impact of COMMIT • 146, 153
 - impact of COPY • 151, 153

- ViewPoint component • 10

W

- wildcard character • 25
- windows • 35, 36, 37, 38, 58, 86, 117
 - About (genlevel) • 37, 117
 - Are You Sure? • 36, 58
 - Data Has Not Been Saved • 37
 - prompt • 35
 - Redefine • 38, 86